

# SAAB



## SERVICE MANUAL

SAAB 95

SAAB 96

MONTE CARLO 850

### SAAB MOTORS, INC.

100 WATERFRONT STREET  
NEW HAVEN, CONNECTICUT

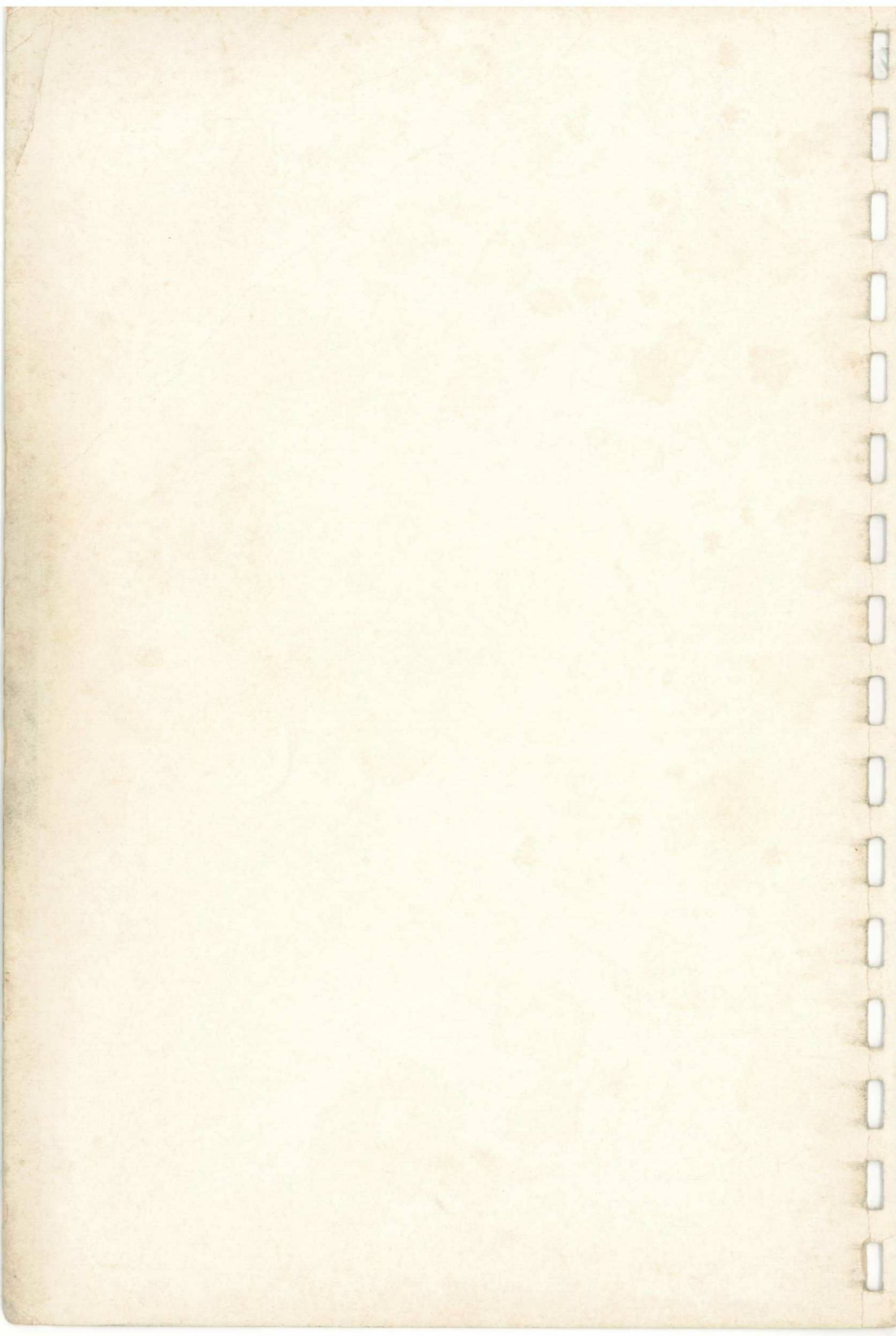



TABLE OF CONTENTS  
FOR  
SAAB 95 AND SAAB 96

<u>CHAPTER:</u>	<u>PAGE:</u>
TECHNICAL INFORMATION. . . . .	1
TROUBLE SHOOTING. . . . .	14
ENGINE . . . . .	31
CLUTCH STANDARD . . . . .	49
CLUTCH SAXOMAT. . . . .	51
TRANSMISSION. . . . .	59
FUEL SYSTEM . . . . .	87
EXHAUST SYSTEM. . . . .	101
COOLING SYSTEM. . . . .	103
FRONT AXLE AND SUSPENSION . . . . .	107
REAR AXLE AND SUSPENSION. . . . .	117
STEERING AND COLUMN GEAR SHIFT. . . . .	118
BRAKES. . . . .	131
CONTROLS. . . . .	144
WHEELS AND TIRES. . . . .	148
ELECTRICAL. . . . .	149
INSTRUMENTS . . . . .	174
BODY. . . . .	177
INTERIOR. . . . .	189
LUBRICATION AND SERVICE . . . . .	191
ACCESSORIES. . . . .	197

TABLE OF CONTENTS  
FOR  
MONTE CARLO 850

<u>CHAPTER:</u>	<u>PAGE:</u>
TECHNICAL INFORMATION . . . . .	201
ENGINE . . . . .	206
FUEL SYSTEM . . . . .	216
EXHAUST SYSTEM . . . . .	221
FRONT AXLE AND SPRINGING . . . . .	222
BRAKE SYSTEM . . . . .	224
ELECTRICAL SYSTEM . . . . .	230
LUBRICATION AND SERVICE . . . . .	239





**1. TECHNICAL INFORMATION**

	Saab 95	Saab 96	GT 750
Overall length, including bumpers . . . . (approx.)	13 ft. 6 in. (4120 mm)	13 ft. 2 in. (4015 mm)	13 ft. 2 in. (4015 mm)
Overall width . . . . .	5 ft. 2 in. (1570 mm)	5 ft. 2 in. (1570 mm)	5 ft. 2 in. (1570 mm)
Overall height, empty . . . . . (approx.)	4 ft. 10 in. (1470 mm)	4 ft. 10 in. (1475 mm)	4 ft. 10 in. (1475 mm)
Road clearance (2 people front) . . . . . (approx.)	7.5 in. (190 mm)	7.5 in. (190 mm)	7.5 in. (190 mm)
Track, front and rear . . . . .	4 ft. (1220 mm)	4 ft. (1220 mm)	4 ft. (1220 mm)
Wheelbase . . . . .	8 ft. 2 in. (2490 mm)	8 ft. 2 in. (2488 mm)	8 ft. 2 in. (2488 mm)
Turning radius . . . . . (approx.)	18 ft. (5.5 m)	18 ft. (5.5 m)	18 ft. (5.5 m)
Empty weight, incl. fuel, water, tools and spare wheel . . . . .	1985 lb (900 kg)	1810 lb (820 kg)	1895 lb (860 kg)

**Weight distribution:**

Empty . . . . . front	54 %	58 %	57.5 %
Fully loaded, incl. pass. and luggage . . . . front	48 %	48 %	49 %
Number of seats . . . . .	7	5	2+2
Available luggage or freight space . . . . .	39 cu. ft. (1.1 m <sup>3</sup> )	13 cu. ft. (0.37 m <sup>3</sup> )	13 cu. ft. (0.37 m <sup>3</sup> )
with full passenger load . . . . .	none		
Loading deck with 5 passengers . . . . .	39×37 in. (1000×950 mm)	39×37 in. (1000×950 mm)	39×37 in. (1000×950 mm)
Loading deck with 2 passengers . . . . .	63×37 in. (1600×950 mm)		
Height of luggage space . . . . .	31 1/2 in. (800 mm)	18 in. (460 mm)	18 in. (460 mm)

**WRENCH TORQUES**

The table below indicates the torques for standard nuts and bolts. For special nuts and bolts see the Technical Data in the appropriate chapter.

Size	Wrench torques		
	kg.-m.	in.-lb.	ft.-lb.
1/4"	0.7— 1.0	61—87	5—7
5/16"	1.5— 2.5	130—220	10—18
3/8"	2.5— 4.0	220—350	18—28
7/16"	4.0— 7.0	350—600	28—50
1/2"	7.0—10.0	600—850	50—72
9/16"	10.0—14.0	850—1200	72—100
5/8"	14.0—20.0	1200—1700	100—145

**THREADS AND WRENCH SIZES**

The thread system employed on Saab is the UNC, i. e. UNIFIED COARSE, inches being the unit of measurement.

Wrench sizes for these nuts and bolts are expressed in inches and the dimensions are identical with the tool sizes.

In a few cases UNF, i. e. UNIFIED FINE, threads have been used. Exceptions to the system will be encountered in the case of components supplied by sub-contractors, such as Bosch, S.U. and Solex etc.



## ENGINE

### SPECIFICATIONS

GENERAL DATA	850 cc.	750 cc. (GT)
Piston displacement .....	51.9 cu.in. (841 cc)	46 cu.in. (748 cc)
Brake horsepower DIN ....	38 at 4250 rpm.	45 at 4800 rpm.
SAE .....	42 at 5000 rpm.	48 at 5000 rpm.
Torque DIN .....	59 ft-lb at 3000 rpm. (8.2 mkg at 3000 rpm.)	61 ft-lb at 3500 rpm. (8.5 mkg at 3500 rpm.)
Bore .....	2.76 in. (70 mm)	2.6 in. (66 mm)
Stroke .....	2.87 in. (73 mm)	2.87 in. (73 mm)
Compression ratio, nominal	7.3:1	9.8:1
Firing order (cyl. 1 at rear)	1—2—3	1—2—3

### DIMENSIONS AND TOLERANCES in mm.

#### Bore, standard

Class A .....	69.987—69.994	65.994—66.001
„ AB .....	69.994—70.001	66.001—66.008
„ B .....	70.001—70.008	66.008—66.015
„ C .....	70.036—70.046	66.043—66.053

#### Bore, oversizes (ÖD\*)

ÖD 0.5 A .....	70.501—70.508	66.508—66.515
ÖD 0.5 B .....	70.508—70.515	66.515—66.522
ÖD 1.0 A .....	71.001—71.008	67.008—67.015
ÖD 1.0 B .....	71.008—71.015	67.015—67.022

#### Piston diameter, standard

Measure at 90° to piston pin

Measure at indicated distance from edge of skirt .....

	20	15
Class A .....	69.930—69.937	65.907—65.914
„ AB .....	69.937—69.944	65.914—65.921
„ B .....	69.944—69.951	65.921—65.928
„ C .....	69.979—69.986	65.956—65.963

#### Piston diameter, oversizes (ÖD\*)

ÖD 0.5 A .....	70.444—70.451	66.421—66.428
ÖD 0.5 B .....	70.451—70.458	66.428—66.435
ÖD 1.0 A .....	70.944—70.951	66.921—66.928
ÖD 1.0 B .....	70.951—70.958	66.928—66.935

	850 cc.	750 cc. (GT)
Piston clearance .....	0.050—0.067	0.080—0.097
Max. permissible clearance between piston and cylinder, approx. ....	0.15	0.18
Out-of-round, piston .....		
Difference between measurements at 90° to pin and in line with pin .....	0.08—0.10	0.08—0.10
Measure at indicated distance from edge of skirt .....	20	15



**ENGINE**

Width of piston rings .....	2.478—2.490	2.478—2.490
Piston ring gap .....	0.25—0.50	0.25—0.50
Piston ring clearance in groove:		
Upper ring .....	0.07—0.12	0.07—0.12
Center ring .....	0.07—0.12	0.06—0.10
Lower ring .....	0.05—0.09	0.05—0.09
Piston pin diameter .....	18	18
Connecting rod side clearance		
Guided at piston		
a. at crankpin .....	—	2.05—2.14
b. at piston pin .....	—	0.10—0.40
Guided at crankshaft		
a. at crankpin .....	0.08—0.12	0.08—0.12
b. at piston pin .....	approx. 4	4
Connecting rod bearing radial clearance .....	0.015—0.020	0.015—0.020
Piston pin radial clearance .....	Should be easy fit with thumb pressure, pin rotatable with two fingers.	
Crankshaft lateral throw, maximum .....	0.05	0.05
Compression in new engine (at engine temperature of 175° F (80° C) with open throttle and full starter r.p.m.)	psi. ....	112±7    138±7
	kg/sq.cm. ....	7.9±0.5    9.8±0.5

**CLUTCH  
STANDARD****SPECIFICATIONS**

Clutch type .....	dry single plate
Clutch pedal free movement at tip of pedal .....	3/4—1 in. (20—25 mm)
Clearance release plate flywheel .....	1 in. (26 mm)
Pressure plate springs:	
Length, uncompressed .....	1.95 in. (49.5 mm)
" , compressed .....	1.16 in. (29.4 mm)
Tension when compressed .....	108—115 lb. (49—52 kg)
Minimum permissible tension .....	100 lb. (45 kg)
Dimensions of clutch facing .....	7×5×0.14 in. (180×125×3.5 mm)
New disc:	
Thickness, unloaded .....	9,1—9,4 mm (0,36—0,37 in.)
Thickness, loaded with 350 kp .....	8,3—8,7 mm (0,33—0,34 in.)
Clutch pressure .....	294—312 kp

**SPECIAL TOOLS**

Description	Part. No.
Clutch lever spacers .....	784065
Clutch centering tool .....	784064



## CLUTCH SAXOMAT

### SPECIFICATIONS

Type of clutch .....	Saxomat
Release bearing clearance at approx. 2,000 r.p.m. ....	0.08—0.12 in. (2—3 mm)
Release bearing clearance at approx 2,000 r.p.m. measured at linkage lever .....	0.35—0.50 in. (9—13 mm)
Gear lever contact gap (1/4 turn of socket nut) .....	0.006—0.008 in. (0.15—0.20 mm)
New disc:	
Thickness, unloaded .....	8,3—8,7 mm (0,33—0,34 in.)
Thickness, loaded with 350 kp .....	7,6—8,0 mm (0,30—0,35 in.)
Gear lever's point gap .....	0,15—0,20 mm (0,006—0,008 in.)

adjustment can be done by  
turning the sleeve nut 1/4 turn.

### SPECIAL TOOLS

Description	Part. No.
Clutch centering tool .....	784064

## TRANSMISSION

### SPECIFICATIONS

Oil required, approx. ....	4 pints (2 liters)
Type of oil (see Lubrication Chart, Chapter 15):	
Saab 95 and 96 .....	SAE 90 EP
Saab GT 750 .....	SAE 80 EP
Overall transmission ratios	
	Saab 96      Saab 95      GT 750
	3-speed      4-speed      4-speed
1st gear .....	16.7: 1      19.3: 1      18.3: 1
2nd gear .....	8.5: 1      11.4: 1      10.7: 1
3rd gear .....	5.1: 1      7.0: 1      6.6: 1
4th gear .....	—      4.5: 1      4.3: 1
Reverse .....	21.0: 1      17.6: 1      16.7: 1
Ratio, ring gear and pinion .....	5.43: 1      5.43: 1      5.1: 1
No. of teeth, pinion/ring gear .....	7: 38      7: 38      7: 36

### Road speed in m.p.h. at 1,000 r.p.m. engine speed:

	Saab 96	Saab 96	Saab 95	GT 750
	3-speed	4-speed	4-speed	4-speed
1st gear .....	4.3	3.7	3.8	3.8
2nd gear .....	8.4	6.3	6.4	6.6
3rd gear .....	14.0	10.3	10.4	10.7
4th gear .....	—	15.7	15.9	16.1
Reverse .....	3.4	4.1	4.1	4.6

### Road speed in km/h at 1,000 r.p.m. engine speed:

	Saab 96	Saab 96	Saab 95	GT 750
	3-speed	4-speed	4-speed	4-speed
1st gear .....	6.9	5.9	6.0	6.1
2nd gear .....	13.4	10.0	10.3	10.5
3rd gear .....	22.4	16.4	16.8	17.1
4th gear .....	—	25.1	25.5	26.0
Reverse .....	5.4	6.5	6.6	6.7

Pinion/ring gear adjustment: specified dimension  $\pm$  0.002 in. (0.05 mm)  
Ring gear lash: specified dimension  $\pm$  0.002 in. (0.05 mm)





**TRANSMISSION**

Matched gear sets	
3-speed gear box	4-speed gear box
3rd speed drive gear 3rd speed gear wheel	3rd speed drive gear 3rd speed gear wheel
2nd speed drive gear 2nd speed gear wheel	4th speed drive gear 4th speed gear wheel
Crown wheel Pinion shaft	Crown wheel Pinion shaft
Syncromesh	Syncromesh

**SPECIFICATIONS**

**FUEL SYSTEM**

**GENERAL DATA**

Fuel tank capacity, approx.:	
Saab 95 .....	11.5 gal. US (43 liters)
Saab 96 and GT 750 .....	10.5 gal. US (40 liters)
Fuel pump, all models .....	S.U. part No. AUA 79 or 89
Contact gap, approx. ....	0.03 in. (0.75 mm)
Pump capacity, free delivery at pump .....	8 gph. (30 l/hour)
Del. head at (15 l/h— 11 —4 min.) capacity .....	12—34 in. (320—850 mm)
Del. head at zero capacity .....	20—43 in. (500—1100 mm)

**CARBURETORS**

**Solex carburetor, normal settings:**

	40 AI or 40 BI	44 PIH
Main jet system	1.1 in. (28 mm)	1.3 in. (32 mm)
Choke tube .....	135	—
Main jet, Saab 95 and 96 (850 cc) .....	150	150
Saab GT 750 (750 cc) .....	250	300
Emulsion tube jet .....	1	19
Emulsion tube .....		
Idling system		
Idling air jet .....	100	140
Idling fuel jet .....	45	50
Cold starter system		
Starter air jet .....	3.5	
Starter fuel jet .....	190	
Needle valve .....	2.0	2.5
Float weight .....	0.75 oz. (21 gr)	0.35 oz. (10 gr)
Float level with 23 1/2 in. (600 mm.) fuel column (normal pump pressure) .....	0.78 in. ±0.04 (21 mm ± 1)	0.78 in. ±0.04 (20 mm ± 1)
Volume control screw .....	1 1/2—2 turns	2—2 1/2 turns

**Zenith carburetor, normal settings:**

	34 VNN
Main jet system	
Choke tube .....	1.2 in.



## FUEL SYSTEM

Main jet .....	107
Compensating jet .....	110
Main air jet .....	200
<b>Idling system</b>	
Fuel jet .....	50
Idling air bleed (drilled in barrel) .....	140
Air (richness) regulating screw, opening .....	1 1/2—2 turns
Needle, valve 0.08 in. (2 mm) seat washer .....	2.0
Throttle opening with closed strangler flap .....	0.040—0.045 in. (1.1—1.2 mm)
<b>Fuel level with float chamber removed:</b>	
Float in position .....	1.02 in. (25.5 mm)
Float removed .....	1.18 in. (30 mm)
<b>Fuel level with float chamber assembled and fitted</b> .....	0.83 in. (21 mm)
<b>Float weight</b> .....	0.22—0.24 oz. (6.2—6.8 gr.)

## EXHAUST SYSTEM

### GENERAL DATA

Exhaust pipe bore:	
Saab 95 and 96 .....	1.34 in. (34 mm.)
Saab GT 750 Super .....	2.01 in. (51 mm.)

## COOLING SYSTEM

### SPECIFICATIONS

Capacity of cooling system:	
Excluding heater system .....	1.82 gal. US (6.9 liters)
Including heater system .....	2.03 gal. US (7.7 liters)
Thermostat temp. range (185° F [85° C]) .....	181°—199° F (83°—93° C)
Thermostat temp. range (170° F [75° C]) .....	163°—181° F (73°—83° C)
Radiator pressure cap opens at .....	3.5—4.5 lb./sq.in. (0.25—0.30 kg/cm <sup>2</sup> )

### TABLES

Freezing point in the table below is the point at which ice crystals start to form in the cooling system. The use of alcohol as antifreeze is not recommended since alcohol evaporates at relatively low temperatures. Both glycol and alcohol may damage the paintwork and should be handled carefully.

#### Water — ethylene glycol mixtures

% of ethylene glycol by vol.	Freezing point		Boiling point		Spec. gravity
	° C	° F	° C	° F	
10	— 4	25	101	214	1.012
20	—10	14	102	216	1.027
30	—17	2	103	217	1.041
40	—26	—15	104	219	1.055
50	—39	—38	106	223	1.068
60	—56	—68	109	228	1.076





## COOLING SYSTEM

Data for various quantities of glycol in the system

US quarts (liters) of glycol in system	Approx. % by volume	Freezing point		Boiling point		Specific gravity
		° C	° F	° C	° F	
1 quart (1 l.)	13	-6	21	101	214	1.017
2 quarts (2 l.)	25	-14	7	103	217	1.034
3 quarts (2.9 l.)	38	-24	-11	104	219	1.055
4 quarts (3.8 l.)	50	-39	-38	106	223	1.070

## FRONT AXLE AND SUSPENSION

### SPECIFICATIONS

Front shock absorbers, length, compressed .....	9 3/4 in. (250 mm)
extended .....	14 1/2 in. (370 mm)
stroke, fitted .....	3 1/4 in. (82 mm)
Front coil springs, No. of turns .....	11
Wire diam. ....	0.46 in. (11.7 mm)
Front coil springs, length .....	15 in. (380 mm)
Maximum spring expansion, front .....	5 1/2 in. (140 mm)
Front wheel alignment, no load:	
King pin inclination .....	7 ± 1°
Caster .....	2 ± 1/2°
Camber .....	3/4 ± 1/4°
Toe-in at wheel rim .....	0.08 ± 0.04 in. (2 ± 1 mm)
Turning angles:	
Outer wheel .....	20°
Inner wheel .....	22 1/2 ± 1 1/2°

### TORQUES

Castle nut, front wheel hub: .....	17—20 kpm 1450—1700 in.-lb., 125—145 ft.-lb.
------------------------------------	--

### SPECIAL TOOLS

The following Saab special tools are required for work on the front axle and suspension.

Description	Part. No.
Rule for measuring toe-in .....	784001
Hub puller .....	784002
Tie rod end extractor .....	784004
Wrench for axle shaft seal nut, front wheel hub .....	784020
Drift for front wheel bearing .....	784075
Coil spring compressor .....	784081
Coil spring clamp, for disassembly and assembly .....	784082
Press tool upper rubber bushing springing arm .....	784133
Press tool lower rubber bushing springing arm .....	784134



## REAR AXLE AND SUSPENSION

SPECIFICATIONS	Saab 95	Saab 96 and GT 750
Maximum spring expansion .....	6 3/4 in. (170 mm)	6 3/4 in. (170 mm)
Rear coil springs, length .....	13 1/2 in. (342 mm)	13 1/2 in. (342 mm)
Rear coil springs, No. of turns .....	9	9
Rear coil springs, wire diam. ....	0.45 in. (11.4 mm)	0.43 in. (11 mm)
Shock absorbers, type .....	Arm, hydraulic	Telescopic, hydraulic
Shock absorbers, stroke .....	4 1/4 in. (106 mm)	4 1/4 in. (106 mm)

### REAR WHEEL ALIGNMENT:

Camber .....	0° ± 1°
Toe-in, both wheels together .....	0° ± 1°
measured rim-to-rim .....	0 ± 7 mm (0.28 in.)
Toe-in for each wheel must not exceed .....	0° ± 3/4°
Maximum difference in wheelbase, left and right (front wheels pointing straight forward) .....	0.6 in. (15 mm)

### TORQUES

Crown nut, rear wheel hub: 9—10 kpm, 780—870 in.-lb., 65—72 ft.-lb.

### SPECIAL TOOLS

The following Saab special tools are supplied for work on the rear axle and suspension.

Description	Tool No.
Hub puller .....	784002
Driver, ball bearing .....	784032
Driver, ball bearing .....	784033
Socket wrench, grease nipple .....	784036
Driver and extractor, bushing .....	784073
Driver and holder, bushing .....	784076

## STEERING AND COLUMN GEAR SHIFT

### SPECIFICATIONS

Steering gear adjustments:	
Pinion side clearance .....	.004—.008 in. (0.1—0.2 mm)
Rack radial clearance .....	max. .012 in. (0.3 mm)
Steering ratio, mean .....	14: 1
Wheel motion, full lock to full lock .....	2 1/4 turns
Tie-rod ends:	
Distance between wrench flat and locknut .....	max. 1.5 in. (40 mm)
Permissible diff. in distance between left and right-hand ends .....	max. .08 in. (2 mm)

### TORQUE-WRENCH SETTINGS

Nut, tie-rod end: 3.5—5 kgm., 300—440 in.-lb., 25—36 ft.-lb.

**STEERING AND COLUMN GEAR SHIFT****SPECIAL TOOLS**

The following special tools are required for work on the steering and column gear shift.

Description	Tool No.
Ratchet wrench, inner ball joint .....	784071
Tool for driving off tie-rod ends .....	784004
Disassembly tool for taper pin in interm. shaft .....	784083

**SPECIFICATIONS****BRAKES****GENERAL**

	Types I and II	Type III
Make .....	Lockheed	Lockheed
Type, front .....	Two leading shoe	self adjusting
rear .....	One leading shoe	One leading shoe
Footbrakes .....	Hydraulic	two—circuit type
Handbrake .....	Mechanical	Mechanical

**DIMENSIONS, ETC**

	Type I	Type II	Type III
Brake drum, front .....	9" (228.6 mm)	9" (228.6 mm)	9" (228.6 mm)
Brake drum, rear .....	8" (203.2 mm)	8" (203.2 mm)	8" (203.2 mm)
Master cylinder .....	7/8"	3/4"	3/4"
Wheel cylinder, front .....	7/8"	0.8"	0.8"
Wheel cylinder, rear, SAAB 95 & 96 .....			
Wheel cylinder, SAAB 95 & 96 .....	7/8"	3/4"	3/4"
Wheel cylinder, rear, GT 750 .....			
Wheel cylinder, GT 750 .....	3/4"	3/4"	3/4"
Brake shoes, front .....	9" × 1 3/4"	9" × 1 3/4"	9" × 1 3/4"
Brake shoes, rear .....	8" × 1 1/2"	8" × 1 1/2"	8" × 1 1/2"
Brake hoses, front .....	10 1/2"	10 1/2"	10 1/2"
Brake hoses, rear .....	15 1/2"	8 1/2"	8 1/2"
Brake tube, reservoir—master cylinder .....	5/16" Bundy	Hose	Hose
Other brake tubes .....	3/16" Bundy	3/16" Bundy	3/16" Bundy

Brake fluid .....

Lockheed Super Heavy Duty	Brake Fluid, specification SAE 70 R 3 or equivalent
---------------------------	---

Clearance between master-cylinder piston and push-rod, minimum .....	0.0315 in. (0.8 mm)	0.0315 in. (0.8 mm)	0.02–0.05 in. (0.6–1.2 mm)
Correct clearance at brake pedal top .....	0.2–0.4 in. (5–10 mm)	0.2–0.4 in. (5–10 mm)	0.12–0.24 in. (3–6 mm)

Adjustment machining of brake drums permitted to diam. (max.):

Front .....	9.059 in. (230.1 mm)
Rear .....	8.059 in. (204.7 mm)
Max. total indicated radial brake-drum throw .....	.006 in. (0.15 mm)

**TORQUES**

Castle nut, front wheel hub .....	17–20 kgm., 1440–1700 in.-lb. 122–144 ft.-lb.
Castle nut, rear wheel hub .....	9–10 kgm., 800–850 in.-lb. 65–72 ft.-lb.

**SPECIAL TOOLS**

The following special Saab tool will be required for work on the brakes:

Description	Part No.
Puller .....	784002





## CONTROLS

Distance from brake/clutch pedal pad to toeboard	6 1/2 in. (160 mm)
Max. pedal travel, approx. ....	3/4—1 in. (20—25 mm)
Free movement, clutch pedal, at pedal top .....	3/16—3/8 in. (5—10 mm)
Free movement, brake pedal, at pedal top up to model 1963	0.12—0.24 in. (3—6 mm)
Free movement brake pedal, at pedal top from model 1964.	2 in. (50 mm)
Total travel, accelerator pedal, approx. ....	

## WHEELS AND TIRES

### SPECIFICATIONS

#### WHEELS

Type .....	wide base
Size .....	4J×15"
Depth of drop center .....	1.77 in. (45 mm.)
Permissible out-of-round, rim (A in fig.) .....	0.1 in. (2.5 mm.)
Permissible out-of-round, rim (B in fig.) .....	0.1 in. (2.5 mm.)

#### TIRES

Size, Saab 96, tubeless .....	5.00×15"
Size, Saab 95, tubeless .....	5.60×15"
Tire pressures, Saab 96:	
light load .....	Front      Rear
full load .....	25 psi. (1.8 kg./cm <sup>2</sup> )    22 psi. (1.6 kg./cm <sup>2</sup> )
full load .....	25 psi. (1.8 kg./cm <sup>2</sup> )    25 psi. (1.8 kg./cm <sup>2</sup> )
Tire pressures, Saab 95:	
light load .....	24 psi. (1.7 kg./cm <sup>2</sup> )    24 psi. (1.7 kg./cm <sup>2</sup> )
full load .....	25 psi. (1.8 kg./cm <sup>2</sup> )    28 psi. (2.0 kg./cm <sup>2</sup> )
Size, GT 750, with tube .....	155×15"
Tire pressures	
Front .....	22—24 psi (1.5—1.7 kg/cm <sup>2</sup> )
Rear .....	21—23 psi (1.4—1.6 kg/cm <sup>2</sup> )

#### WHEEL BOLTS

Wrench size .....	3/4" (19.05 mm.)
Thread .....	SAE 9 16"—12 UNC—2

#### TORQUE SETTINGS

Wheel bolts .....	8—10 kgm 670—850 in.-lb. 58—72 ft.-lb.
-------------------	--



**ELECTRICAL**

**BATTERY**

Voltage .....	12 V
Capacity .....	54 Ah

**GENERATOR, Bosch**

Type .....	IJ/GEG 160/12/2500+W30R4
Rated output .....	160 W
Rated voltage .....	12 V
Rated speed .....	2500 r.p.m.
Max. permissible load .....	20 A
Direction of rotation .....	Clockwise
Brush spring pressure .....	450—600 grammes

**CHARGING RELAY, Bosch**

Up to model 1963	
Type designation .....	RS/TBA 160/12/1
Cut-in voltage .....	12.4—13.1 V
Voltage setting when idling .....	14.3—15.3 V
Voltage setting when loaded with 15 A .....	13.5—14.5 V
Return current relay breaks at .....	3—9 A
Max. effect .....	240 W

From model 1964	
Type designation .....	RS/VA 200/12/A2
Cut-in voltage .....	12.3—13.3 V
Voltage setting when idling .....	13.8—14.8 V
Voltage setting when loaded with 25 A .....	13.3—14.3 V
Return current relay breaks at .....	2—7.5 A
Max. effect warm regulator .....	300 W
Max. effect cold regulator (2—3 minutes from starting) .....	420 W

**STARTER MOTOR, Bosch**

Type designation Saab 95 and Saab 96			
To chassis No. 1120 and 112499 respectively .....		CD/0,5/12AR12	
From chassis No. 1121 and 112500 respectively .....		AL/EDD 0,5/12R4	
Type designation Saab GT 750 .....		AL/EDD 0,5/12R4	
		previously CDD 0,5/12R8	
Number of teeth on pinion .....			9
Number of teeth on ring gear .....			97
Brush spring pressure .....			550—700 grammes

**DISTRIBUTOR, Bosch**

	Saab 95 and 96	Saab 95 and 96	Saab GT 750
Type designation .....	VJ3 BR8T	VJU3 BR1T and VJU3 BR2T	VJ3 BR7T
Capacitor .....	LMKO 1 Z30Z	LMKO 1 Z42Z	LMKO Z30Z
Ignition setting:			
Basic setting .....	10° B.T.D.C.	7° B.T.D.C.	2° B.T.D.C.
At 3000 r.p.m. ....	20° B.T.D.C.	17° B.T.D.C.	22° B.T.D.C.
		(Vacuum hose disconnected)	

Order of firing (cyl. 1 = rear) .....	1—2—3	1—2—3	1—2—3
Breaker point gap .....	0.3—0.4 mm	0.3—0.4 mm	0.3—0.4 mm
Dwell angle .....	77°—83°	77°—83°	80°—84°
Contact pressure .....	400—500 grammes	400—500 grammes	1100—1200 grammes
Direction of rotation .....	Clockwise	Clockwise	Clockwise
Shaft end play .....	0.1—0.2 mm	0.1—0.2 mm	0.1—0.2 mm

**IGNITION COIL, Bosch**

Type designation combined with		Saab 95 and 96	Saab GT 750
ignition switch .....	ZS/KZ 1/12 A		ZS/KZ 2/12 A
without ignition switch .....	TK 12 A4		TK 12 A10
Serial resistance .....	—		ZWJ 11 Z4Z
Model 1964 Type designation .....		K12	



## ELECTRICAL

SPARKS PLUGS, for example Bosch		Saab 95 and 96 Saab GT 750	
Normal driving	.....	M 225 T1	M 240 T1
Hard driving	.....	M 240 T1	M 270 T16
Spark gap clearance with normal ignition cables	..	0.7 mm	0.7 mm
with resistance	.....	0.8 mm	0.8 mm
Thread	.....	18 mm	18 mm
Tightening torque	.....	4,5 kpm	4,5 kpm

BULBS	All cars	Philips No.	Watts
Sealed Beam USA	2 pcs.		50/40
Head light asymmetric	2 pcs.	12620	45/40
Turn indicators/parking lights front	2 pcs.	1034 25/7 or 32/4 CP	
Turn indicator stop lights, rear	2 pcs.	1073 25 W	32 CP
Tail light	2 pcs.	12821	5
Number plate lights	2 pcs.	12844	5

	Saab 95	Saab 96	GT 750	Philips No.	Watt
Courtesy light	2 pcs	1 pc	1 pc	12844	5 W
Warning and instruments model 1960—63	3+2 pcs	3+2 pcs	4+2 pcs	12913	2 W
Warning and instruments model 1964	—	10 pcs	—	12829	2 W
Warning and fuel gauge model 1964	5 pcs	—	—	12829	2 W
Remaining instrument lights model 1964	4 pcs	—	—	12913	2 W
Back-up light	—	—	2	1034	25 W
Luggage compartment lamp	—	1	—	12929	4 W
FUSES	10+2 pcs	10+2 pcs	10+2+4 pcs		8A

## FLASHER RELAY

Type designation:

Lucas	.....	FL5 12V 42 W
Hella	.....	91 PSt 2x32 Cp 12 V

## HORN, Hella

Type designation ..... B 31—12 V

## FUEL GAUGE TANK UNIT, VDO

Type designation, Saab 95	.....	VDO K 22.000
Saab 96	.....	VDO 20.228
GT 750	.....	VDO 625

## WINDSHIELD WIPER MOTOR

Type designation, Bosch	.....	WS/GA 12/14
SWF, LHD cars	.....	SWA 1105/66b
SWF, RHD cars	.....	SWA 1105/66r

## HEATER FAN MOTOR

Type designation, Bosch	.....	KM/RCC 25/12—2500 R 5
Electrolux	.....	KS 3442/240

## WINDSHIELD WASHER MOTOR, Bosch (GT 750 only)

Type designation	.....	WS/SPE 2/12/1
------------------	-------	---------------





## INSTRUMENTS

## SPEEDOMETER DRIVE RATIOS

Model	Ratio Ring gear/pinion	Dynamic radius of road wheel in. mm.		Speedometer	
				Rev. per km covered	Rev. per mile covered
95	38: 7	12.2	(310)	643	1035
96	38: 7	12.0	(305)	654	1052
GT 750	36: 7	11.7	(298)	634	1020
GT 750 (3-speed)*	34: 7	11.7	(298)	599	964

\* Earliest version of GT 750, with 3-speed transmission.

## BODY

## SPECIFICATIONS

Basic body dimensions	Saab 95		Saab 96 och GT 750	
	Overall length .....	13 ft. 4 in. (4060 mm)	12 ft. 7 in. (3830 mm)	5 ft. 2 in. (1565 mm)
Greatest width .....	5 ft. 2 in. (1565 mm)	4 ft. 1 in. (1265 mm)	4 ft. 1 in. (1240 mm)	4 ft. 1 in. (1240 mm)
Greatest height .....	661 lbs (300 kg)	568 lbs (258 kg)	507 lbs (230 kg)	423 lbs (192 kg)
Weight of body assembly fully fitted ..				
„ excg. doors, fenders and rear compartment lid .....				

## SPECIAL TOOLS

Alignment tool, body diagonal measurement .....	Part No. 784077
Alignment tool, installation of power unit .....	784078

**ENGINE****STARTING DIFFICULT — COLD ENGINE**

<b>SOURCE OF TROUBLE</b>	<b>REMEDY</b>
A. Dirty plugs, or short circuit in ignition circuit due to dampness of plug insulators, ignition cables, coil or distributor cover.	Clean or replace spark plugs; wipe ignition cables, plug terminals, ignition coil and distributor cover.
B. Fuel pump not working.	Check electrical connections at pump, incg. ground, and check fuses and fuse contacts. Check that line between pump and carburetor is not blocked or restricted by sharp bend. Check whether breaker contacts in pump need replacement.
C. Jets and ducts in cold-start device choked up.	Blow jets and ducts with air.
D. No current in primary or secondary circuits.	Check all cable connections especially at ignition switch to ensure that current is supplied to ignition system when starter is engaged. Cable rupture may have occurred at the locking ignition switch.

**STARTING DIFFICULT — WARM ENGINE**

A. Float riding too high in carburetor.	Adjust float level — see Chap. 6, Fuel System.
B. No current in primary or secondary circuits.	Check as described under 1. 1. D.

**SPARK KNOCK**

A. Ignition timed too early.	Adjust ignition setting — see Chap. 15, Electrical.
B. Incorrect jets fitted in carburetor (mixture too weak).	Fit correct jets. See Chap. 6, Fuel system, under "Technical Information".
C. Automatic advance in distributor sticks at earliest timing.	Test distributor on a test bench, if available. Clean and lubricate all parts, and replace any faulty items.
D. Sparks plugs graded too soft ("cool").	Check plug grading and replace with correct type if necessary.
E. Large carbon deposits in combustion chamber due to unusual amount of city driving.	Decarbonize cylinder head.



**SOURCE OF TROUBLE**

**REMEDY**

- D. Ice formation in emulsion tube. Induction preheater duct removed from air cleaner. Refit preheater duct. The preheater should be left in place the year round, except during unusually warm summer weather.
- E. Insufficient compression. Sticking or damaged piston rings. Carry out compression test. Disassemble engine, decarbonize and possibly fit new rings.

**ENGINE NOISE**

Always remove the fan belt before tracing untoward engine noise. Remember, however, that the engine will become overheated if run too long without the belt fitted. If in any doubt as to whether the noise originates in engine or transmission depress the clutch pedal to disengage transmission.

- A. Grinding noise from engine. If noise sounds different when clutch pedal is depressed, causing longitudinal loading of crankshaft bearings, then defective main bearings may be the cause. Disassemble crankshaft and inspect bearings. The front main bearing is replaceable.
- B. Knocking, related to engine speed and most pronounced when reducing from high revolutions to low. Pistons scoring cylinders due to overheating or other cause. A rough check can be made if induction and exhaust manifolds, possibly also cylinder head, are removed. If scoring is thought to occur, disassemble engine, replace damaged pistons and restore scored cylinder barrels by honing or reboring. Similar knock may arise after a long mileage, due to excessive piston clearance. This "piston slap" can usually be removed only by repistoning, and a careful check must be made to see whether o.d. pistons will be required to maintain specified clearances.
- C. Rustling noise when idling. If thought to originate in distributor or distributor gear, grip distributor housing for confirmation. Grease breaker cam assy. in distributor. Refill distributor-gear grease cup. If noise disappears but re-occurs after a short period check and possibly replace distributor gear.
- D. Irregular clicking — due to damaged piston ring or ring retainer. Generally similar measures to those under 1.7. B.
- E. High-pitched rattle occurring in all gears at approx. same r.p.m. — probably nut on crankshaft for vibration damper is not fully tightened, but front muffler can give rise to a similar noise. Retighten nut for vibration damper with 36 ft.-lb. (5 kgm) torque. If noise persists, try a new front muffler.



## OVERHEATING

SOURCE OF TROUBLE	REMEDY
A. Fan belt slipping.	Adjust belt tension.
B. Faulty thermostat.	Inspect thermostat and test its opening temperature, or try a new thermostat.
C. Ignition unduly retarded.	Check and if necessary readjust ignition settings.
D. Incorrect carburetion. (Too weak.)	Check jets and carburetor adjustments.
E. Cooling-water hoses rotted by oil or grease.	Inspect cooling system and replace defective hoses.
F. Choked cooling system.	Flush cooling system.

ENGINE MISFIRES WHEN ACCELERATING, WILL NOT  
REV.-UP PROPERLY

A. Damaged or dirty spark plugs.	Clean and test, or replace, spark plugs.
B. Short-circuit in ignition cables; damp in distributor cover.	Inspect and clean cables and distributor cover, if necessary.
C. Faulty ignition coil.	Test coil, replace if necessary.
D. Excessive breaker contact gap and/or burnt points.	Inspect points and replace if necessary. Adjust to correct gap, .014—.016 in. (0.3—0.4 mm).
E. Restricted exhaust system.	Check exhaust system, especially rear muffler.
F. Water in fuel.	Inspect fuel-pump filter (lowest point) for water, also float chamber.
G. Fuel supply disturbed.	Check carburetor jets, float level, fuel-pump pressure, etc. See Chap. 6, Fuel System. Check that no air leakage occurs at the gasket between inlet manifold and cylinder block or at carburetor.





## CLUTCH, STANDARD AND SAXOMAT

### CLUTCH SLIPS

SOURCE OF TROUBLE	REMEDY
A. Incorrect adjustment of clutch pedal — no free travel.	Adjust free travel to $\frac{3}{4}$ —1 in. (20—25 mm.) at pedal tip.
B. Shaft for clutch release fork, clutch cable, guide pulley or pedal not moving freely.	Check and lubricate these parts to ensure free movement.
C. Oil on clutch facing.	Remove inspection door. Check whether oil is entering past clutch shaft seal — if so, remove engine from car and disassemble clutch for cleaning and possibly replacement of facing. Fit new shaft seal.
D. Worn clutch facing.	Replace clutch facing. Check flywheel, pressure-plate and pressure-plate spring tension.
E. Pressure-plate springs too weak.	Check springs — see Chap. 4, Clutch.
F. Faulty or incorrectly adjusted pressure plate.	Inspect pressure plate and check adjustment — see Chap. 4, Clutch.

### INCOMPLETE DISENGAGEMENT

A. Clutch pedal incorrectly adjusted — excessive free movement.	Adjust pedal travel to $\frac{3}{4}$ —1 in. (20—25 mm.) at tip.
B. Pressure-plate levers incorrectly adjusted.	Engine must be removed for check and adjustment of levers — see instructions in Chap. 4, Clutch.
C. Clutch disc skew or (new) facings too thick.	Check for skewness or incorrect facing thickness.
D. Disc hub not moving freely on shaft.	Remove inspection door. Lubricate carefully with a few drops graphite oil. For best results, remove engine and lubricate shaft and hub with graphite grease.



## SOURCE OF TROUBLE

## REMEDY

- |   |   |
|---|---|
| E. Clutch shaft bushing at rear end of crankshaft damaged.  | Remove engine. Inspect bushing, polish smooth or replace. Lubricate with graphite grease. |
| F. Pin retaining clutch fork on vertical release shaft is faulty, allowing relative motion of fork and shaft. | Remove engine and transmission. Replace pin, possibly also fork and shaft.                |

## CLUTCH GRABS

- |   |                  |
|---|------------------|
| A. Oil on clutch facing.  | As under 2.1. C. |
| B. Vertical release shaft, clutch cable, guide pulley or pedal sticking intermittently. | As under 2.1. B. |
| C. Faulty or incorrectly adjusted pressure plate.                                       | As under 2.1. F. |

## DEFECTIVE RELEASE BEARING

The release bearing, a grease-filled ball bearing, should always be disassembled when overhauling the transmission. Otherwise water, cleaning fluid or other extraneous matter may enter the bearing and cause damage with resultant noise symptoms.

- |   |   |
|---|---|
| A. Noise occurring when the clutch pedal is depressed is the usual sign of release bearing trouble. | To replace bearing, remove engine. The bearing must be serviced as a complete unit. |
|---|---|

## SAXOMAT CLUTCH

CENTRIFUGAL CLUTCH SLIPS AT FULL ACCELERATION  
OTHER THAN IMMEDIATELY AFTER GEAR SHIFT

- |  |  |
|--|--|
| A. Linkage rod to servo not correctly adjusted.            | Check that clearance exists between release bearing and pressure washer at r.p.m. in excess of 2,000. See Chap. 4, Clutch (Saxomat).   |
| B. Oil on facings.   | Remove inspection door. Check whether oil is entering past clutch shaft seal — if so, remove engine from car and disassemble clutch for cleaning and possibly replacement of facing. Fit new shaft seal. |
| C. Clutch overheated or some part of clutch assy. damaged. | Remove engine, disassemble clutch and inspect for damaged parts; replace these.  |



### CLUTCH SLIPS TOO LONG AFTER GEAR SHIFT

#### SOURCE OF TROUBLE

#### REMEDY

- |  |   |
|--|---|
| A. Reducer-valve adjustment screw too tight.                       | See adjustment instructions for operating valve in Chap. 4, Clutch (Saxomat). |
| B. Bleeding diaphragm adjustment screw not sufficiently tightened. | See adjustment instructions for operating valve in Chap. 4, Clutch (Saxomat). |

### INCOMPLETE DISENGAGEMENT WHEN CAR STOPS, CAUSING TENDENCY TO CREEP FORWARD

- |   |  |
|---|--|
| A. Idling speed too high.   | Adjust idling speed to about 800 r.p.m.  |
| B. Centrifugal clutch incorrectly adjusted or springs are fatigued. | Remove and check centrifugal clutch. If any fault is detected replacement will be necessary as correction can be undertaken only with special equipment.     |
| C. Clutch disc hub sticking on clutch shaft.                        | Remove inspection door. Lubricate carefully with a few drops graphite oil. For best results, remove engine and lubricate shaft and hub with graphite grease. |
| D. Clutch disc skew, or facing is deformed or damaged.              | Remove engine and centrifugal clutch. Inspect and if necessary replace clutch facings and/or disc hub.   |

### INCOMPLETE DISENGAGEMENT DURING GEAR SHIFTS IN MOTION

- |  |   |
|--|---|
| A. Servo linkage rod incorrectly adjusted. | Check that clearance exists between release bearing and pressure washer at r.p.m. in excess of 2,000. See Chapter 4, Clutch (Saxomat).  |
| B. Servo diaphragm damaged.                | Check servo for quick action when shift-lever switch is closed. If action is sluggish and suction lines are satisfactory (see 2.9.D) then diaphragm may be at fault. Replace entire servo assy. |

### NO DISENGAGEMENT DURING GEAR SHIFTS IN MOTION

- |   |                                  |
|---|----------------------------------|
| A. Short in solenoid circuit. Fuse blown. | Check fuse and solenoid circuit. |
|---|----------------------------------|



SOURCE OF TROUBLE	REMEDY
B. Ground lead from gear-shift lever broken or making poor connection.	Check and if necessary replace ground lead.
C. Excessive contact gap in shift-lever switch or corroded contacts.	Clean contacts and adjust gap to .014—.016 in. (0.15—0.20 mm.).
D. Restricted or leaky suction line.	Check for restriction or damage.
E. Servo damaged.	As under 2.8. B.
F. Operating-valve solenoid defective.	Replace operating-valve solenoid.

#### NO RE-ENGAGEMENT AFTER GEAR SHIFT IN MOTION

A. Shift-lever switch not breaking.	Check contact gap and inspect contact surfaces for smoothness and cleanliness. See that gearshift lever movement in sleeve nut is not restricted by burr.
B. Cable between solenoid and shift lever is grounded.	Inspect cable insulation for abrasion, e. g. at shift lever.

#### CLUTCH GRABS

A. Grease or oil on clutch facing.	Remove inspection door. Check whether oil is entering past clutch shaft seal—if so, remove engine from car and disassemble clutch for cleaning and possibly replacement or facing. Fit new shaft seal.
B. Centrifugal clutch incorrectly adjusted.	Remove and check centrifugal clutch. If any fault is detected replacement will be necessary as correction can be undertaken only with special equipment.
C. Pressure plate or flywheel clutch face are skew or irregular.	Remove engine to permit inspection of clutch friction surfaces. Replace flywheel or centrifugal clutch as required. As regards the latter, see previous para.





## TRANSMISSION

### OIL LEAKAGE

When oil leakage occurs always check bleeding through shifter shaft in transmission case cover. The outlet is in the shifter shaft between the cover and the shift-shaft universal joint. The simplest method of checking is as follows: Remove transmission case oil-level plug, inject compressed air into case and feel simultaneously for exhaust from the bleed opening. If a restriction is suspected, remove the cover for further checking. Check that the oil level is not too high.

#### SOURCE OF TROUBLE

#### REMEDY

- |   |   |
|---|---|
| A. If leakage via the clutch shaft seal is suspected, check by removing the inspection cover from the clutch housing.   | Engine must be removed to permit replacement of the clutch shaft-seal. Simultaneously disassemble and check both clutch and clutch facings. |
| B. Leak through seal for outgoing drive shaft.  | Replace shaft seal. Check that rubber of inner drive-shaft universal joint has not been damaged by oil.                                     |
| C. Leak at speedometer drive wire. If oil escapes at the connection between the outer wire and the instrument then the speedo. gear is probably feeding-up oil. | Replace speedometer drive assy. in transmission case. Clean cable and possibly instrument also.   |

### DIFFICULT TO SHIFT GEAR WHEN CAR IS STATIONARY

- |   |  |
|---|--|
| A. Steering-wheel bearing bracket incorrectly located so that it restricts longitudinal motion of gear-shift shaft. | Check that equal movement is possible in all gear positions. If adjustment is required, back off 2 bolts retaining bracket and adjust location, towards or away from dash panel. |
|---|--|

### DIFFICULT TO SHIFT GEAR IN MOTION

- |   |   |
|---|---|
| A. Timid action by driver causes scraping.                          | Shift gear in a positive, though not violent, manner.   |
| B. Synchronizing-unit blocking rings are worn or otherwise damaged. | Replace blocking rings. A light grinding with carborundum paste will assist accurate matching of ring friction surfaces; clean all affected parts carefully after using paste, however. |



SOURCE OF TROUBLE	REMEDY
C. Steering-wheel bearing bracket incorrectly located so that it restricts longitudinal motion of gearshift shaft.	Check that equal movement is possible in all gear positions. If adjustment is required, back off 2 bolts retaining bracket and adjust location, towards or away from dash panel.
D. Shift forks are bent, worn or otherwise defective.	Remove and disassemble transmission case for inspection and repair.

### NOISE FROM TRANSMISSION CASE

When diagnosing transmission-case noises concentrate first on drive shafts and related components. See also Trouble Shooting, Front Axle and Suspension.

A. Noise from differential assy. — characterised by lower note when load is light.	Remove engine and transmission assy. for replacement of ring gear and pinion.
B. Noise from gears — characterised by a higher, sharp note when gear train is under load.	For elimination, gear set must be replaced. Judge each case according to seriousness of noise.
C. Slight rattling from transmission case when engine is idling and car is stationary — emitted by intermediate gears when not under load.	No action required.

### FUEL SYSTEM

#### PUMP DOES NOT START OR WORKS IMPROPERLY

SOURCE OF TROUBLE	REMEDY
A. Inner nut at fuel pump electrical connection tightened too hard.	Back off nut a little so that bakelite cover is just firmly held against pump body.
B. Poor contact at pump electrical connections.	Check connections at pump, also at fuse block and fuse contact surfaces.
C. Impurities in fuel system.	Check that lines between tank and carburetor are not restricted. If dirt in tank is suspected, remove the tank for flushing.
D. Condensate in fuel causing ice blockage (winter time).	Inspect for ice formation in fuel pump and lines. Possibly fuel tank will require draining and refilling with fresh fuel.
E. Fuel-pump breaker contacts burnt or worn.	Remove bakelite cover from pump to inspect contact points. If replacement is required, fuel pump must be removed — see Chap. 6, Fuel System.
F. Leakage from pump body — traces of fuel noted on breaker base plate.	Inspect pump diaphragm with a view to replacement.

**FUEL SYSTEM****PUMP DOES NOT START OR WORKS IMPROPERLY**

SOURCE OF TROUBLE	REMEDY
A. Inner nut at fuel pump electrical connection tightened too hard.	Back off nut a little so that bakelite cover is just firmly held against pump body.
B. Poor contact at pump electrical connections.	Check connections at pump, also at fuse block and fuse contact surfaces.
C. Impurities in fuel system.	Check that lines between tank and carburetor are not restricted. If dirt in tank is suspected, remove the tank for flushing.
D. Condensate in fuel causing ice blockage (winter time).	Inspect for ice formation in fuel pump and lines. Possibly fuel tank will require draining and refilling with fresh fuel.
E. Fuel-pump breaker contacts burnt or worn.	Remove bakelite cover from pump to inspect contact points. If replacement is required, fuel pump must be removed — see Chap. 6, Fuel System.
F. Leakage from pump body — traces of fuel noted on breaker base plate.	Inspect pump diaphragm with a view to replacement.

**INCORRECT FUEL GAUGE**

A. Gauge registers too low or too high.	Remove tank sender unit and adjust by careful bending of float arm.
B. Gauge working only intermittently or not at all.	Fit new gauge or tank unit to determine exact location of fault. Replace faulty part



## EXHAUST

### LOSS OF PERFORMANCE

#### SOURCE OF TROUBLE

- A. Restricted exhaust system.

#### REMEDY

Experience indicates that the rear muffler is the first to suffer from choking. The next possibility is that the bore of the exhaust pipe has been reduced by deposits or damage.

## COOLING SYSTEM

### OVERHEATING

#### SOURCE OF TROUBLE

- A. See under Overheating in section on Trouble Shooting, Engine.

#### REMEDY

### TEMPERATURE TOO LOW

- A. Difficult to maintain an adequately high cooling-water temperature (wintertime).

Check thermostat opening temperature possibly by testing a new thermostat in the car. For screening airflow, adopt following measures in named order: close radiator blind, fit covers in wheelhouse, screen intakes on both sides of front grille and fit screen in left wheelhouse behind radiator; a blind may also be fitted in front of the radiator but the owner must then be instructed in the importance of correct regulation.

## FRONT AXLE AND SUSPENSION

### GREASE LEAKAGE AT FRONT-WHEEL HUB

#### SOURCE OF TROUBLE

- A. Bearing grease has seeped into brake drum and damaged brake lining. Due to inspection hole in drum, grease will also be visible on outside of drum and wheel.

#### REMEDY

Disassemble wheel, brake drum and seal retainer. Replace seal and brake lining. Check facing surface of brake drum against seal.

### PLAY IN WHEEL BEARINGS

- A. Determined most easily by jacking up front end to relieve wheels. Noise — especially when cornering — abnormal tire wear and poor road holding may be caused by play in wheel bearings. Correct clearance is  $5/64$  in. (2 mm.) measured at rim.

Replace wheel bearings and seal between bearings and universal joint — see Chap. 9. When changing bearings, pack the new ones with good-quality grease (ball-bearing grade). Check rubber bellows over outer universal joint.



**PLAY IN UNIVERSAL JOINTS**

- A. Play in universal joints of drive shafts is less frequently encountered. If it occurs it may be betrayed by a knocking in time with shaft revolutions when freewheeling at low speeds. Same noise may be caused by wear of ball and ball seat on inner and intermediate shafts, resp.
- Slight play in joints and drive shafts is not serious and does not call for action. However, rubber bellows and grease in joints should be renewed. To completely eliminate noise, defect parts must be replaced.

**FRONT-END NOISE**

- A. Banging or tapping noises may be caused by the springs when driving on cobbles or similar surfaces. It may be possible to twist springs a little but only sure remedy is to fit new springs.
- B. Scraping or squeaking noise during motion — may be due to absence of lubricant in sealing collar of rubber bellows. Lubricate with oil or grease.

**REAR AXLE AND SUSPENSION****REAR-END NOISE****SOURCE OF TROUBLE****REMEDY**

- A. Damaged rear-wheel bearings may give rise to a scraping or rumbling noise during motion. Jack up rear of car. A fault in a rear-wheel bearing will be localised if the wheels are spun alternately.
- B. Squeaking or knocking from the rear is probably from shock absorbers or brackets (Saab 95). Best way to eliminate possibility of shock absorbers is to test new ones. Check simultaneously shock-absorber rubber cushions.
- C. Noise due to faults in rearaxle attachment to body. Check bolted connections and bushings between rear axle and body, at center and side arms.

**INCORRECT ALIGNMENT OF REAR WHEELS**

- A. Incorrect alignment may be due to a bent rear axle. If an axle stub is bent or otherwise damaged it may be replaced without replacing entire axle. However, if axle itself is bent replace it rather than attempt heating and realignment.



## OVERHEATING

SOURCE OF TROUBLE	REMEDY
A. Fan belt slipping.	Adjust belt tension.
B. Faulty thermostat.	Inspect thermostat and test its opening temperature, or try a new thermostat.
C. Ignition unduly retarded.	Check and if necessary readjust ignition settings.
D. Incorrect carburetion. (Too weak.)	Check jets and carburetor adjustments.
E. Cooling-water hoses rotted by oil or grease.	Inspect cooling system and replace defective hoses.
F. Choked cooling system.	Flush cooling system.

## ENGINE MISFIRES WHEN ACCELERATING, WILL NOT REV.-UP PROPERLY

A. Damaged or dirty spark plugs.	Clean and test, or replace, spark plugs.
B. Short-circuit in ignition cables; damp in distributor cover.	Inspect and clean cables and distributor cover, if necessary.
C. Faulty ignition coil.	Test coil, replace if necessary.
D. Excessive breaker contact gap and/or burnt points.	Inspect points and replace if necessary. Adjust to correct gap, .014—.016 in. (0.3—0.4 mm).
E. Restricted exhaust system.	Check exhaust system, especially rear muffler.
F. Water in fuel.	Inspect fuel-pump filter (lowest point) for water, also float chamber.
G. Fuel supply disturbed.	Check carburetor jets, float level, fuel-pump pressure, etc. See Chap. 6, Fuel System. Check that no air leakage occurs at the gasket between inlet manifold and cylinder block or at carburetor.



## **STEERING**

### **HARD STEERING**

#### **SOURCE OF TROUBLE**

#### **REMEDY**

- A. Steering gear adjustment tightened too hard. See Chapter 11 for adjustments of rack and pinion clearances.
- B. Poor lubrication or use of wrong lubricant for steering gear and ball joints. Refill steering-gear and ball-joint grease cups, simultaneously turning wheel to full lock.
- C. Steering-column bushings are binding due to tension between bushings and column. Adjust steering-column bracket bolts to relieve tension.

### **KNOCKS OR RATTLES FROM STEERING**

- A. Steering gear too slackly adjusted. See Chapter 11 for adjustments.
- B. Play in ball joints or tie-rod ends. Check, adjust or replace worn parts.

### **ABNORMAL KICKBACK TO WHEEL**

- A. Poorly lubricated driving-shaft universal joints. Inspect and if necessary replace rubber bellows on outer joints. Lubricate joints, simultaneously massaging rubber bellows to work grease into joint.
- B. Intermediate drive shaft corroded fast in splines of inner universal joint. Lubricate (but never excessively) with oil can at hole provided. This hole is not provided on earlier Saab 93 models, so that disassembly of drive shaft may be necessary.



## BRAKES

Poor braking effect is usually due to bad adjustment, air in the brake fluid or worn linings. When fitting new linings always use genuine Saab parts. If linings of a newer type are fitted on earlier cars, be sure to replace them on both front wheels or rear wheels, as appropriate. See also Chap. 12, Brake System.

### UNEVEN BRAKING

SOURCE OF TROUBLE	REMEDY
A. Car drags to one side when braking: grease on brake lining is probable cause.	Disassemble brake drums and inspect linings. Replacement of linings and wheel-bearing shaft seal may be needed.
B. Brake drums on opposite sides are unevenly worn.	Machining in pairs or replacement of worn or damaged drum. See Chap. 12, Brake System, concerning turning down of brake drums.
C. Car drags towards one side, and the brake pedal travel is excessive. In a two-circuit-system (from chassis 201.401 on the 96 model and on the 95 model from chassis 10.801) one circuit is out of operation as a result of leakage.	Check for and remedy leaking brake lines, brake hoses and brake pistons.

### BRAKES DRAG

A. Apart from excessive adjustment of brake shoes, drag may be caused by sticking brake pistons.	Disassemble brake drums for check of wheel cylinders and possibly replacement of sticking pistons.
B. Return hole in master cylinder not uncovered when brake pedal is released, due to incorrect adjustment of push rod or swollen gaskets.	Check play between push rod and pedal (should be 1/32 in. (0.8 mm.) or 3/16—3/8 in. (5—10 mm.) at pedal tip). If gaskets are thought to be at fault, replace these.
C. Incorrect or deficient brake fluid in system.	Check condition of fluid. If it is unsatisfactory, flush system carefully with methylated spirits and replace all rubber gaskets.
D. Brake hoses choked, restricting return of oil after braking.	Check that brakes are immediately released when pedal is released.
E. Handbrake wire not returning correctly or wheel cylinders sticking.	Check, clean and relubricate.



**WHEELS AND TIRES****TIRES UNEVENLY WORN**

SOURCE OF TROUBLE	REMEDY
A. Uneven tire wear is usually due to lack of balance in the wheels, either inherent or resulting from the adhesion of mud, etc., on the inside.	Shift wheels regularly, left front to left rear and right front to right rear, in order to spread "heel-and-toe" wear. Check wheel balance at regular intervals and correct as necessary.
B. Worn center or edges of tread is usually caused by excessive or insufficient tire pressure.	Adjust inflation to recommended pressures, with due regard to load carried.
C. Scraped-off, feathered or cross wear is usually due to incorrect wheel adjustments (often called "toe-in/toe-out wear").	Check toe-in, caster, camber, king-pin alignment and turning angles.
D. Worn wheel bearings or tie-rod ends; possibly also skew wheel discs.	Check wheel bearings and steering assy. Check wheels for skewness.

**WHEEL SHIMMY**

A. Unbalanced wheels.	Clean wheels, check balance if required.
B. Poorly lubricated drive-shaft joints. Intermediate shaft corroded fast in splines.	

**CAR DRAGS TO ONE SIDE**

A. Tire pressure too low on front wheel.	Check and correct inflation pressures.
B. Camber adjustment incorrect.	Adjust camber. If driver is nearly always alone, a compensation may be made by adjusting camber to the following: left side $1/2^\circ$ , right side, $1^\circ$ .
C. Tire and wheel skew or out-of-round.	Check tires and wheels.
D. Poorly lubricated drive-shaft joints. Intermediate shaft corroded fast in splines.	



## ELECTRICAL

### BATTERY RUN DOWN

SOURCE OF TROUBLE	REMEDY
A. Fan belt slack.	Adjust belt tension — see Chap. 15, Electrical.
B. Battery fluid too low.	Check fluid level in battery cells.
C. Faulty battery.	Check that specific gravity is identical in all cells after charging.
D. Generator giving too little current or relay cutting early.	Carry out charging test. Check leads.
E. Short circuit in starter switch.	Disassemble and inspect contacts.

### DEFECTIVE LIGHTS

A. Bulbs burn out: charging voltage is too high, or lead connections are poor, leading to crystallisation of bulb filaments.	Check cut-out relay settings. Inspect all connectors.
B. Weak headlights.	Check bulbs, connectors, reflectors, panel switch and dimmer switch.
C. Stop light or directional signals, front or rear, not working.	Check lamp ground leads to fenders. Check bulbs and flasher relays.

For faults in fuel and ignition systems see sections on Trouble Shooting, Engine and Fuel System.



### 850 cc (Saab 95 and 96)

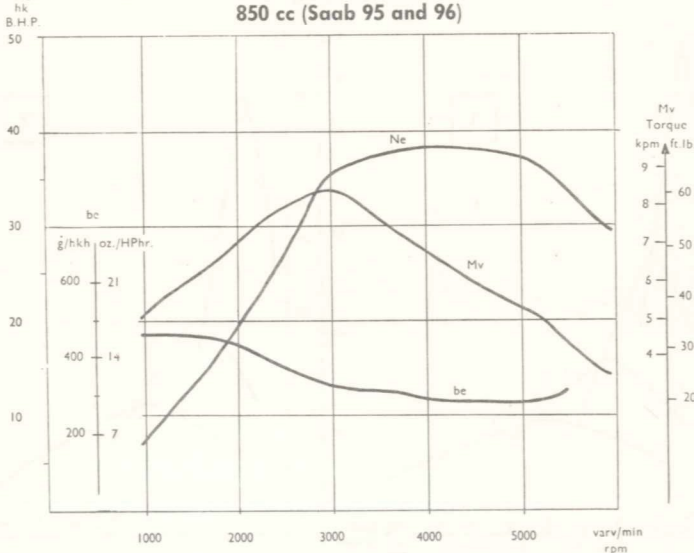

### 750 cc (Saab GT 750)

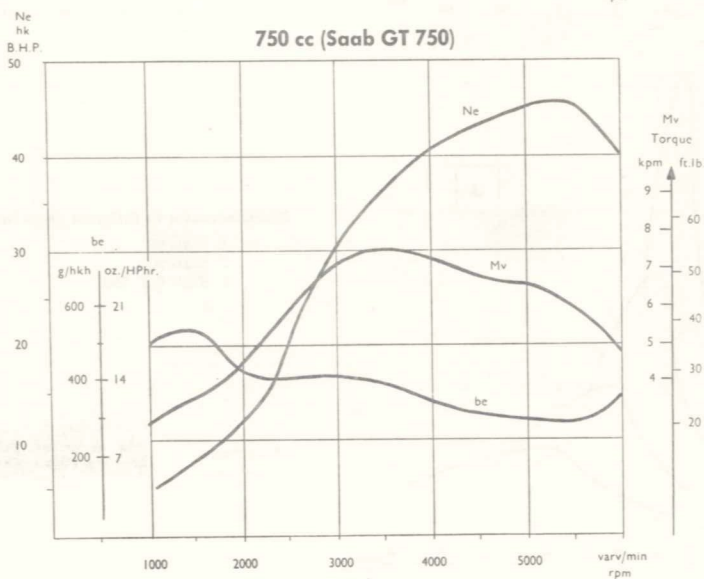

Engine performance curves

Ne = output in b.h.p.      be = fuel consumption

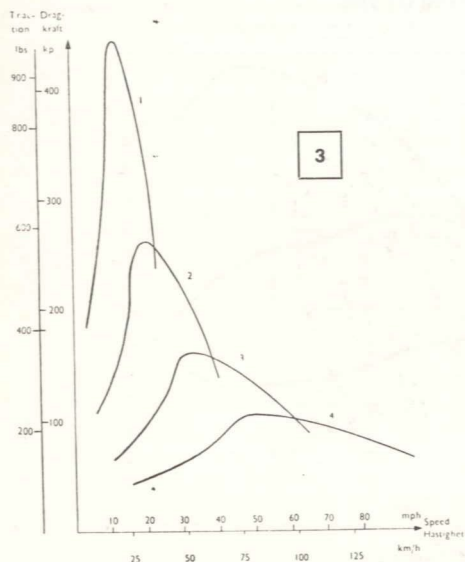
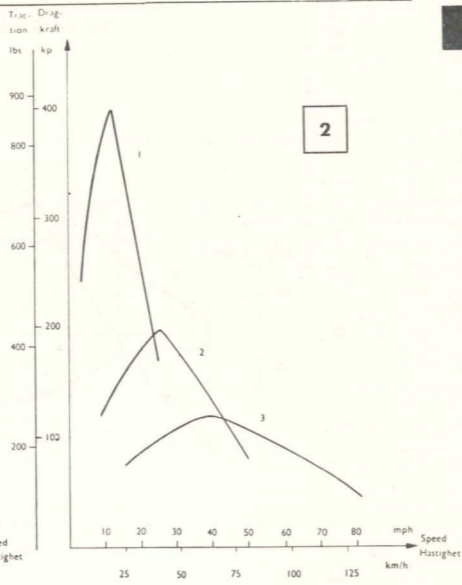
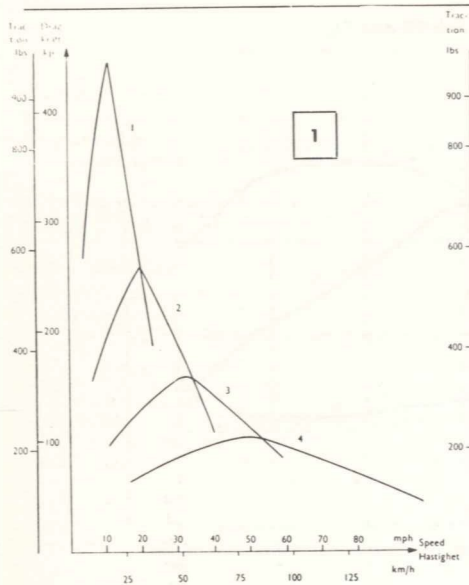

Traction curves in different gears for:

1. Saab 95
2. Saab 96
3. Saab GT 750



## DESCRIPTION

### GENERAL

The Saab engine is a three-cylinder, watercooled two-stroke with crankcase scavenging, piston-controlled ports and cylinder scavenging on the Schnürle principle. The engine is lubricated by oil mixed with the gasoline.

The Saab 95 and 96 models are fitted with an identical engine of 850 cc. The engine fitted in the GT 750 has 750 cc. displacement

The cylinder block and crankcase lower half are cast in nickel alloy steel and machined together. To ensure that these parts remain mated the crankcase number is punched into both on either side of the joint, at the right rear of the engine.

The cylinder head and water necks are made of a light alloy.

The crankshaft is an extremely sturdy fabricated unit comprising six crank webs and seven crank pins assembled by press fit. This permits the use of single ball bearings and double roller bearings as main and connecting rod bearings, respectively.

The crankshaft, which is fitted with a torsional vibration damper, is carried in four main bearings. Seals of piston-ring type are used between the three crankcase compartments and in the flywheel end of

the crankcase. Each seal comprises two piston rings seated in grooves and acts like a labyrinth seal. The crankcase is sealed at the front of the engine by the rubber gaskets on the two distributor gear covers.

It is most important that the crankshaft be correctly built-up and it should therefore be returned to the makers for reconditioning.

The drop-forged and hardened connecting rods carry the piston pin in a needle bearing, while the big end is arranged so that its internally ground surface forms the outer race for the connecting rod bearing.

In the 850-cc. engine, and in the GT-750 engine, from chassis number 118.980, the connecting rods are of the piston-guided type. In the earlier design of the 850-cc. engine, and in the GT-750 engine up to chassis number 118.979, they were crank guided.

The standard 850 cc. engine has Ringstreifen pistons, while the 750 cc. engine has all-aluminium pistons. In both engines, however, the pistons are fitted with chromed steel rings.

Output of the Gran Turismo 750 engine has been increased by such measures as modification and polishing of the inlet, exhaust and transfer ports and raising the compression ratio.

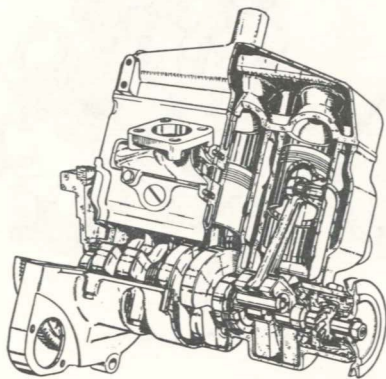

Sectioned engine



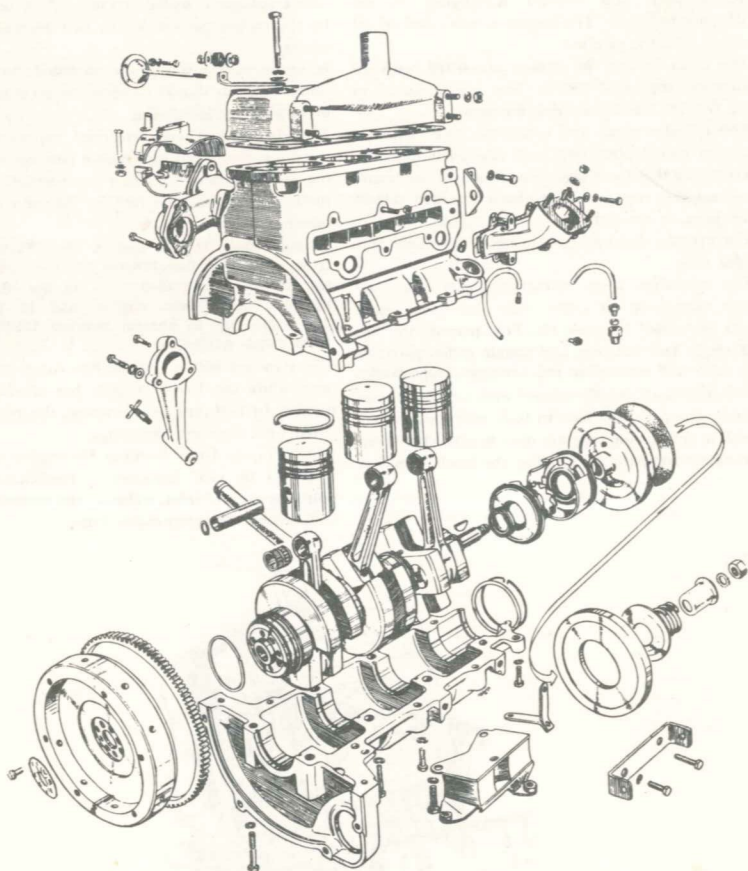

Exploded view of engine.



## REMOVAL AND INSTALLATION

### REMOVAL

1. Disconnect battery ground cable.
2. Remove hood by
  - a) disconnecting cables to lamps and horns, blind chain and hood stopper,
  - b) moving hood to rear and upwards until it slips off hinge pins.
3. Drain cooling system.
4. Disconnect generator cables, distributor primary cable and distributor cover with spark plug cables.
5. Remove induction muffler with cleaner and preheater.
6. Disconnect fuel hose and cold start control from carburetor. Disconnect throttle linkage rubber bellows from plate on throttle shaft.
7. Back off nut retaining muffler.
8. Disconnect muffler pipe from exhaust manifold and lower muffler to floor.
9. Disconnect both engine front supports from body — all six bolts are accessible from under engine space floor pan.
10. Disconnect engine side stay.
11. Unscrew water temperature gauge sending unit.
12. Disconnect water outlet hose at thermostat.
13. Disconnect water outlet hose at pump.
14. Lift engine sufficiently to block up gearbox with a 3 1/2 in. (90 mm.) wood block, for example (see fig.).
15. Back off and remove both starter retaining bolts and place starter on engine space floor. Note: cables and controls need not be disconnected from the starter.
16. Disconnect clutch cable from engine assembly by releasing cable tension and unhooking cable from eye under engine.
17. Separate engine from gearbox and lift out engine using the lift hook 784059. Be extremely careful to avoid straining clutch shaft and shaft seal.

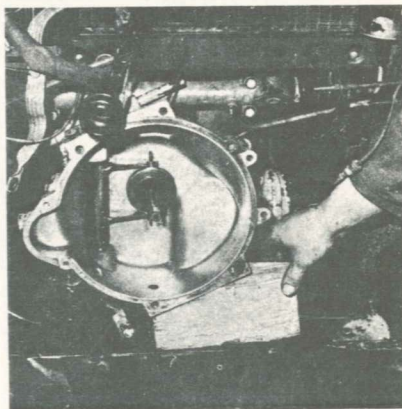

Lifting out the engine. Note the wooden block. Under the gearbox.

### INSTALLATION

1. Check that splines on clutch shaft are undamaged, applying a little graphite grease if necessary. Lift engine and lower it into car. Use hook 784059, see fig.
2. Bolt engine to gearbox and reconnect engine ground cable. Do not omit eye for clutch cable.
3. Refit clutch cable.
4. Refit starter.
5. Remove block from under gearbox and lower assembly.
6. Refit engine side stay.
7. Bolt engine front supports to body.
8. Refit muffler by reconnecting it to exhaust manifold and muffler bracket. Note. Do not tighten bracket nut.
9. After tightening manifold connection, finally tighten bracket nut.

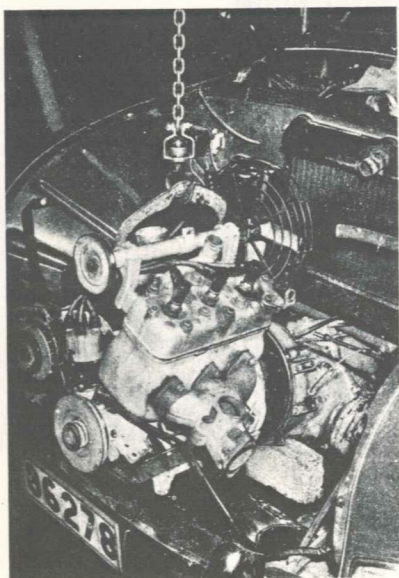

10. Screw in water temperature gauge sender unit.
11. Reconnect cables to generator, distributor cover and spark plugs.
12. Reconnect throttle and cold start controls.
13. Reconnect cooling water hoses.
14. Reconnect fuel hose to carburetor.
15. Refit induction muffler with cleaner and pre-heater.
16. Adjust ignition timing as described in Chapter 15.
17. Refit hood. Reconnect electrical cables, blind chain and hood stopper.
18. Refill cooling system.
19. Reconnect battery ground cable.
20. Adjust clutch pedal play.
21. Test engine.

## DISASSEMBLY

1. Clean engine externally.
2. Remove fan belt, generator and water pump.
3. Remove inlet manifold complete with carburetor.
4. Remove exhaust manifold.
5. Back off cylinder head bolts, remove cylinder head with fan shaft bearing stand. Remove gasket.
6. Back off clamp screw and remove distributor.
7. After checking that bench is clean and perfectly flat, turn engine over so that it stands on top of cylinder block, see fig.
8. Remove clutch assembly. Insert spacers 784065 under clutch levers and back off clutch retaining screws. Remove clutch.
9. Back off crankshaft pulley retaining nut and remove vibration damper and pulley. If necessary, use puller tool 784055.
10. Release lock washer and back off flywheel bolts; remove flywheel.
11. Remove engine supports from crankcase lower half and water inlet neck from cylinder block.
12. Back off bolts and lift off crankcase lower half.
13. Lift out crankshaft with pistons. Be very careful to avoid bending connecting rods or damaging pistons. Removal is simplified by inserting clutch centering tool 784064 in crankshaft bushing and applying tool 784057 to the stub at other end of crankshaft. See fig.
14. Collect retainer ring and shims for the distributor gear case cover.
15. Remove outer cover from crankshaft.
16. With puller 784051 remove distributor drive pinion, then remove the inner cover and its O-ring.
17. Remove piston pin retaining rings and press out pins with tool 784061. Be very careful, and hold up with hand to prevent bending of connecting rods or damage to pistons.

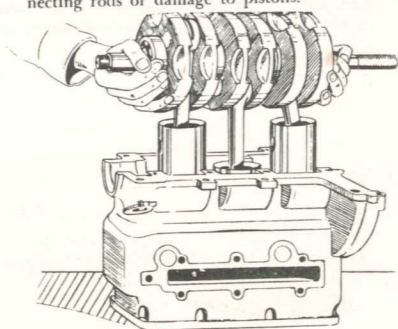

Removal or installation of crankshaft.



### REASSEMBLY

Inspect and clean all parts of the engine, replacing damaged parts and preferably all gaskets. A new cylinder head gasket must always be fitted. See table in Section 1 for torque settings. See appropriate sections for inspection and reconditioning of engine parts.

1. Measure cylinders and pistons to check that clearances are correct. For classification of new pistons where necessary, see Sect. 7.
2. Check needle bearing clearances or determine grading of new needle bearings if pistons or crankshaft have been replaced. See Sect. 7.
3. Refit pistons to connecting rods. Use tool 784061, applying guide pin first to locate needle bearing, after which piston pin may be fitted with driver. Fit pin retaining rings.
4. Apply tool 784057 to front end of crankshaft and insert centering tool 784064 in crankshaft bushing. Locate piston ring gaps opposite lock pin and lower crankshaft with pistons into cylinder block. See fig. Oil pistons and cylinder bores thoroughly before refitting and take care not to damage piston rings.
5. Remove both tools and refit crankcase lower half, tightening bolts in sequence. Use torque 18 ft-lb. (2.5 kpm) for 5/16" bolts and 29 ft-lb. (4 kpm) for 3/8" bolts.

#### NOTE.

No sealing paste or gasket should be used in the joint between the cylinder block and the crankcase lower half. Check that the surfaces are clean and undamaged and oil with motor oil.

6. Refit engine supports and water inlet neck. Coat gaskets on both sides with sealing paste.
7. Refit flywheel, using a new lockwasher. Tighten bolts with a hex torque wrench set to 20—24 ft-lb. (3 kpm/22 ft-lb.). Secure bolts.

#### NOTE.

Special bolts are used for the flywheel.

8. Place clutch plate and refit clutch assembly. Check that all three spacers 784065 are in position. Center clutch plate with arbor 784064 while tightening screws successively. Afterwards, remove arbor and collect spacers.

### IMPORTANT

Certain flywheels and clutches are paint-marked to ensure clutch balance. These marks should be located at 180° from each other.

9. Refit distributor gear case inner cover with O-ring and shaft seals. Use tool 784056 to avoid damage to seals. Locate cover with cut-out opening at hole for distributor.
10. Insert woodruff key and press distributor pinion in place, with chamfered side inwards.
11. Fit outer cover with O-ring and shaft seals. Apply tool 784057 to crankshaft stub and press cover into place by screwing in tool. Note that arrow on cover should point towards ignition timing mark for T.D.C. on engine block.
12. Insert shims outside of cover and fit retainer, making sure that it is fully pressed down into its groove.
13. Back off tool between 1/4 and 1/2 turn and check that shims are hard up against retainer — if not, retainer must be removed and more shims inserted.
14. Remove tool as soon as fit is satisfactory.
15. Fit crankshaft pulley and vibration damper. Do not omit lockwasher under nut. Torque with 32—40 ft-lb. (4.5—5.5 kpm.)
16. Fit cylinder head and gasket in accordance with directions in.
17. Refit inlet manifold and carburetor.
18. Refit generator and connect water inlet hose to pump.
19. Refit fan belt and adjust tension.
20. Refit exhaust manifold.
21. Install the distributor see Chapter 15.
22. Grease distributor gear until excess grease comes out through plastic tube.

#### NOTE.

The wrench torque for cylinder head bolts differ for the 850-cc. and GT-750 engines.





## CYLINDER HEAD

## GENERAL

Allow the engine to cool before removing the cylinder head, to avoid the risk of distorting the head. Inspect the cylinder head for perfect planeness. Correct with a face plate covered with fine emery paper. This is usually fully adequate and machining should be avoided, as this increases compression and may cause knock. If excessive irregularities or distortion are present, replace the cylinder head. Clean plug socket threads with a threading tap. Carbon in the lower part of the threads can cause damage to the threads when a new plug is fitted. Such damage is not irreparable, however: a Heli-Coil thread insert may be used. This also applies to threads for the water temperature gauge sender unit and the fan shaft bearing stand bolts.

## DISASSEMBLY

If only cylinder head is to be removed, proceed as follows:

1. Drain cooling system and let the engine cool off. (Below  $+ 30^{\circ}\text{C}$   $86^{\circ}\text{F}$ ).
2. Remove air cleaner and preheater.
3. Back off generator retaining and adjusting bolts and take off fan belt.
4. Disconnect water hose from cylinder head.
5. Disconnect ignition cables from spark plugs.
6. Unscrew water temperature gauge sender unit.
7. Back off cylinder-head bolts in sequence and remove. Twist engine side stay bracket aside.
8. Remove cylinder head and gasket.

## IMPORTANT.

Sometimes it may be found difficult to remove the cylinder head. If so, slacken the bolts a few turns, and disconnect the ignition cables from the spark plugs. Then crank the engine by means of the starter, and the compression will loosen the cylinder head.

9. Dry off any drops of moisture in cylinders and cover with a clean cloth.
10. If required, remove spark plugs and fan shaft bearing stand, from the cylinder head.

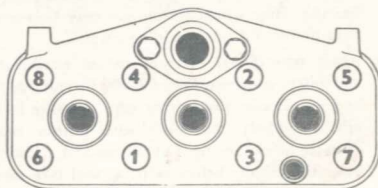
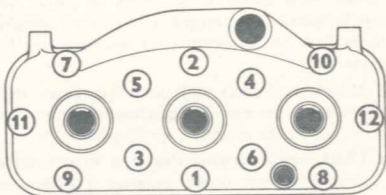

Tightening sequence for cylinder head bolts.

1. 850 cc. — 12 bolts
2. GT 750 cc. — 8 bolts

Reassemble in reverse order, noting that:

When fitting the cylinder head, first clean the contact surfaces of cylinder head and motor block carefully and check that they are flat and smooth. If coolant has entered the crankcase because of a leaky cylinder head gasket, crank the engine, first by hand and then by the starter, blowing at the same time compressed air and thin oil through the carburetor. In this way the coolant — if present — will come out via the transfer ports, simultaneously the engine parts are being oiled.

The cylinder head gasket to be used is black in colour, and has linings only around the cylinders. The material used for gaskets has an internal wire-strengthening. This gasket MUST NOT be coated with any sealing compound, such as Permatex or similar. When fitting the gasket, the same and the contact surfaces must be clean and dry. Center gasket and cylinder head carefully against the engine block, the broad side of the folded-on metal lining to be turned against the cylinder head.

Prior to fitting the cylinder head bolts, clean the thread with a steel brush, then apply a sparing smear of motor oil or graphite grease to the thread. Then tighten the bolts in the sequence and at the wrench torque recommended see foregoing page. After warming up the engine, let it cool (to about  $86^{\circ}\text{F}$ . =  $30^{\circ}\text{C}$ ) before retightening. The retightening to be performed in the same sequence as that of the tightening, but before retightening a bolt slacken it a little in order to make sure that bolt isn't stuck in the thread.





## IMPORTANT!

The cylinder head gasket **MUST NOT** be coated with sealing compound. The surfaces to be dry and well cleaned.

## Wrench Torques:

Saab 95/96	GT 750
12 bolts	8 bolts
36 ft.-lb. (5 kpm)	see below

The first retightening to be done as soon as the engine has cooled after the trial run.

The second retightening to be done at a mileage of 600—1000 miles (1000—1500 km), and the third retightening at a mileage of 1500—2000 miles (2500—3000 km). All retightening to be done with engine **COLD** (below 86°F.=30°C).

## NOTE

Two types of cylinder head bolts are available for the GT 750 engine. The bolt head markings and wrench torques are as follows:

Marking	Wrench Torque	
80	44—50 ft.—lb.	6—7 kpm
100	58 ft.—lb.	8 kpm

## CYLINDER BLOCK

## GENERAL

The cylinder block and the crankcase lower half are machined to match and it is therefore not possible to replace only one or the other. The crankcase number is punched on both sides of the common joint at the right rear of the engine.

Apart from the engine number, punched immediately below the top level of the block on the right side of the engine, the bore class of the various cylinders is punched into the left-hand side of the block. See fig.

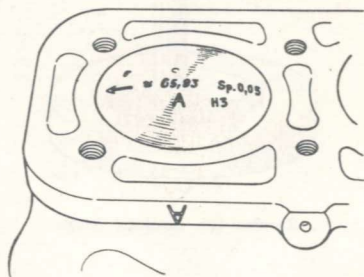

Marking of bore class on the cylinder block.



## MEASUREMENT OF CYLINDER BORE

If the cylinder bore has been damaged by reason of piston scoring or ring fracture, or if excessive wear is noted, the bore must be reconditioned. For inspection use a cylinder bore checking gauge. Normally, bores are worn most at the upper part and therefore become tapered and out-of-round. To obtain a complete picture of the cylinder condition it is necessary to measure at several points and both crosswise and lengthwise. Comparison of maximum and minimum measurements indicates the extent of the wear, but to check true wear it is necessary to zero the checking gauge with the aid of a micrometer — or a control ring — adjusted to the dimension of the class to which the cylinder belongs. (See Technical Information). In such a case, set the micrometer to the lower to-

lerance limit.

Measurement with checking gauge is made as follows.

1. Zero the gauge with the aid of a control ring or a micrometer.
2. Clean the cylinder barrel carefully.
3. Read from the checking gauge to which extent the cylinder bore deviates from normal values. (Re normal values, see Technical Information.) The out-of-round is measured by measuring the bore both lengthwise and crosswise, referring to the block. The draft (tapering) is checked by measuring the bore, first 10 mm (3/8 in.), then 50 mm (2 in.) from the upper edge.

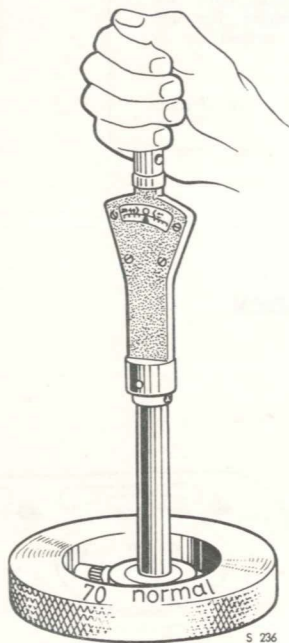

Zeroing the checking gauge

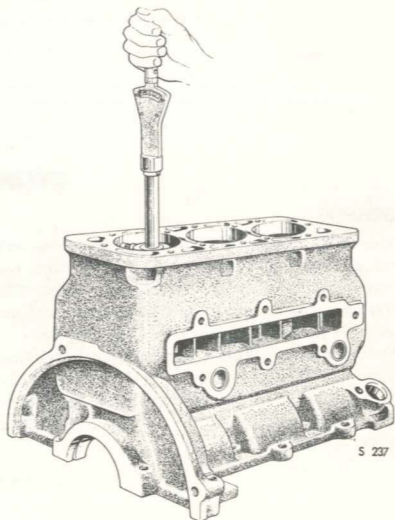

Measuring the cylinder bore



### HONING

When pistons are replaced due to noise (excessive piston play), it is often necessary to hone the cylinder bore, partly in order to remove may-be rims at T. D. C. and small scratches, partly to make the bore suit to the piston class to be used. However, reconditioning of the bores is not necessary if pistons are replaced after a comparatively short mileage. After long mileages it is always necessary to remove the rim at T. D. C.

### REBORING

If reboring must be effected, let the extent of damage decide which oversize to choose. The ports must *always* be rounded at their respective perimeter to the radius shown in the figure — otherwise piston ring fracture may occur. This rounding-off may be made with a scraper bar or a powered finger-type grinding wheel.

#### NOTE!

It is of the utmost importance that all grinding dust, etc. is removed after machining of the cylinder bores. The best method is to wash both block and crank case in a so-called degreasing tank.

### REASSEMBLY OF CRANKCASE

For disassembly and reassembly follow the instructions in Sect. 4. Also observe the following: The joint surfaces between the cylinder block and the crankcase must be perfectly clean. *No form whatsoever of gasket or sealing paste may be used.* The only treatment permitted is oiling the surfaces sparingly. Note that there are two types of bolts, for the different engine models, and that torque moments are different.

#### NOTE!

Do not forget to fit and tighten the rear bolts, located in front of the flywheel.

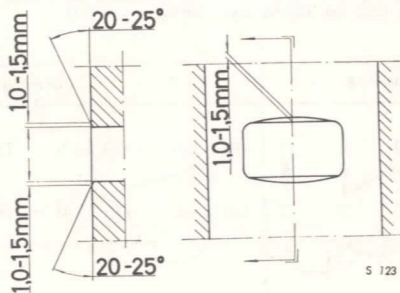

Rounding-off ports.



## PISTONS AND PISTON PIN BEARINGS

### PISTONS

#### GENERAL

Since the 850-cc. (Saab 95 and 96) and the 750-cc. (GT 750) have different cylinder bore diameters, the pistons for these engines must not be mixed up.

For the 750-cc. engine in the GT 750 and the 750-cc. engine in the Saab 93, the cylinders' nominal dimensions are of a kind (NOTE! not of the same bore class), and the pistons differ in other respects — see below.

Markings on the cylinder block, see fig., indicate the piston bore class of the respective cylinder. The markings make it possible to — before going to work — to decide which pistons to fit, and to check that the spare parts department have these in store. Choose piston class on the basis of the cylinder-block marking with the aid of the table below.

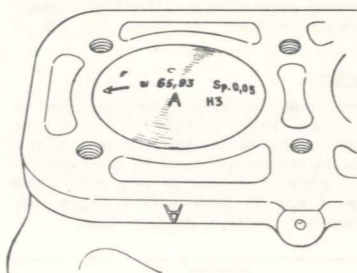

Marking of block and piston

Standard classes Cylinder bore and piston marking	Oversize classes ("ÖD") Cylinder bore and piston marking
A	ÖD 0,5 A
AB	ÖD 0,5 B
B	ÖD 1,0 A
C	ÖD 1,0 B

Table showing piston classes, and combinations permissible to install

As shown by the table above there are four piston — and cylinder classes as Standard, and two Oversizes: one of 0,5 mm and one of 1,0 mm, each divided into two classes. Normally, the piston class and that of the cylinder shall correspond. Provided, however, that the engine has

been run-in i. e. that the cylinder surfaces are broken-in, it is permissible to fit a larger piston class in the Saab 95 and 96. NOTE! This exception is not permitted for the classes B and C, the difference there being considerably larger than between A/AB/B.

	Standard	Oversizes
Cylinder classes	A AB B C	ÖD 0,5 A ÖD 0,5 B ÖD 1,0 A ÖD 1,0 B
Piston classes	A AB B C	ÖD 0,5 A ÖD 0,5 B ÖD 1,0 A ÖD 1,0 B
Difference in mm between classes	0,007 0,007 <u>0,035</u>	0,007 0,007

↑ Normal fitting of piston in cylinder for Saab 95, 96 and GT-750.

S 261

↙ On a run-in engine (above 2000 miles = 3000 km) permitted to fit this piston for Saab 95 and 96.



SAAB 95 and 96 (850-cc.)

The 850-cc. engine in the Saab 95 and 96 is fitted with Ringstreifen pistons, and all piston rings are of chrome-plated steel. These pistons are identified by the interior steel ring in-cast below the bottom piston-ring groove.

In later models have been introduced so-called pistonguided pistons, which means that the surfaces of the piston pin bosses have been machined, and that the small end of the connecting rod has been made wider. The big end of the connecting rod has a big axial play, instead of having this play at the small end of the connecting rod.

GT 750

The GT engine is fitted with an all-aluminium piston characterized by a very thick skirt. The piston rings are of chrome-plated steel. The pistons are crankguided up to chassis No. 118.979, and piston guided from chassis No. 118.980.

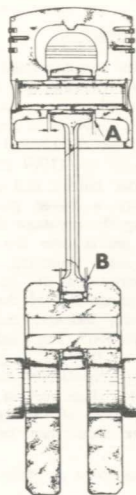

Connecting rod guided at:

- A. Piston pin
- B. Crank pin

When fitting pistons and crankshafts the instructions tabulated below must be observed.

Job	Engine with crank guided connect. rod	Engine with piston guided connect. rod
Replacem. pistons in 95 and 96 engine	Fit pistons intended for piston guided connect. rod	Pistons intended for piston guided connect. rod <i>must</i> be fitted.
Replacem. pistons in GT-750 engine	Fit pistons intended for crank guided connect. rod. Permissible to fit pistons intended for piston guided connect. rod. The difference — if any — in weight between the two types is that little that they can be used together in an engine.	Pistons intended for piston guided connect. rod must be fitted.
Replacem. crankshaft in 95, 96 and GT-750 engine	Crankshaft with piston guided connect. rods should be fitted. Simultaneously must, however, the pistons be changed i. e. pistons for piston guided connect. rod be installed. In this way you get the advantages of piston guided connect. rods. If you do not wish to replace the pistons, a crankshaft with crank guided connect. rods must be fitted.	Crankshaft with piston guided connect. rods shall be fitted.





### FITTING OF PISTONS

If equipment for measurement of pistons and cylinders is not available, the fitting of pistons into cylinder barrels may — in case of need — be made with the aid of a feeler gauge  $\frac{1}{8}$  in.  $\times$  200 mm (approx. 8 in.) and a spring balance graded to min. 35 oz. (1000 g), as follows:

Clean the cylinder barrel, and oil sparingly with a thin oil. Place a feeler gauge of 0,05 mm (0,002 in.) along the pressure side of the barrel, and bring the piston into the barrel from the crankcase side after removing the piston rings. Measure the clearance at 90° to piston pin. Then pull the feeler gauge out of the barrel with the aid of the spring balance, reading the tensile force (sliding friction). The reading shall lie between 21 — 35 oz. (600—1000 g). If the reading is less than what mentioned above, test pistons of the next larger class, and in case the reading is larger test pistons of the next smaller class, until the proper value can be read from the spring balance.

Check the tensile force at different piston travel stages.

#### NOTE!

Width of the feeler gauge shall be  $\frac{1}{2}$  in. (12,7 mm). The feeler gauge shall be operated with a tensile force of 21 — 35 oz. (600 — 1000 g). The cylinder barrel shall be sparingly oiled. If these requirements are complied with, the feeler-gauge thickness will approx. correspond to the piston clearance.

### DISASSEMBLY AND REASSEMBLY

For disassembly and assembly follow instructions.

Pistons and piston pins are paint-marked in various colors to aid correct pairing of pins and pistons. See fig. When changing pistons, for example, and using a complete piston assy. comprising piston, pin and rings, be careful not to interchange the piston pins. Each pin should be fitted together with its appropriate piston.

This is, of course, just as important when the job does not involve replacement of pistons, especially as mixing of the pistons and piston pins will cause difficulties in obtaining the previous needle bearing fit.

The following color marks can be met with:

Red-marked pistons to be fitted with red-marked piston pin. Blue-marked pistons to be fitted with blue-marked pin. Red-marked parts have the greatest diameter.

When fitting piston, piston pin and needle bearing to the connecting rod use guide pin 784061 — see fig. The piston must be held up firmly with the hand during pin fitting to avoid bending of the connecting rod.

#### NOTE.

Fit piston with mark **F** to front.

Do not omit piston pin retaining rings.

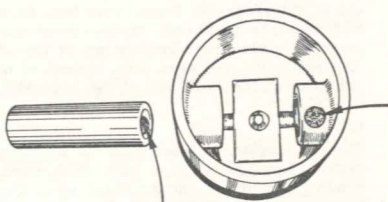

Color marking of piston and piston pin.

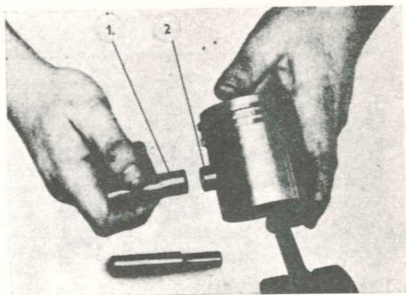

Piston assembly.

1. Piston pin
2. Guide pin

### PISTON PIN BEARING

To meet requirements for an accurate fitting of the piston pin bearing a range of 9 bearings is available. Tolerances and corresponding markings of these bearings are tabulated below, which also indicates the deviation of the bearings from the basic diameter of 0.07874 in. (2.000 mm). Bearings prefixed + are oversizes and normally used only on replacement connecting rods.

connecting rods for replacement crankshafts.

#### NOTE.

Bearings marked without any prefix are — bearings. See fig.



Needle bearing group (in mm.)	Marking
+ 0.008 to + 0.006	+7
+ 0.006 to + 0.004	+5
+ 0.004 to + 0.002	+3
+ 0.002 to 0	+1
+ 0 to - 0.002	-1
- 0.002 to - 0.004	-3
- 0.004 to - 0.006	-5
- 0.006 to - 0.008	-7
- 0.008 to - 0.010	-9

When reconditioning piston pin bearings fit new piston pins and needle bearings.

Before assembling the piston, the piston pin must be matched with a needle bearing giving correct fit in the connecting rod. There should be virtually no play, although the piston pin should not require forcing when fitted in the needle bearing after this latter is fitted in the connecting rod. See fig.

#### WARNING

Light thumb pressure is the maximum permissible when fitting needle bearings. The piston pin should be easily rotatable with two fingers.

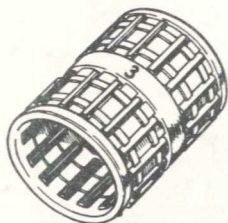

Marking of needle bearings.

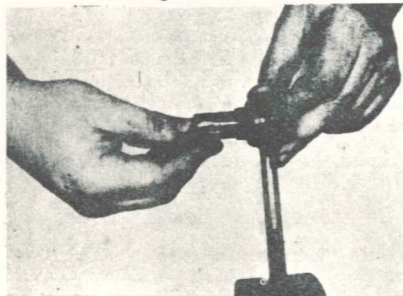

Trying out needle bearing fit.

## CRANKSHAFT

### GENERAL

There are two main types of crankshafts: the standard and the GT-type resp. See figures. The difference is that the GT-shaft has circular crank webs.

### REPLACEMENT OF CRANKSHAFT

For removal and installation of crankshaft, see section 4. Follow the instructions in the table in Sect. 7 when replacing, as there are two types of crankshafts: one with crankguided connecting rods, and one with piston guided connecting rods.

### REPLACEMENT OF MAIN BEARINGS

The crankshaft is a press-fitted assembly, which makes it impossible to replace component parts except for the front main bearing at the distributor drive.

If other parts are damaged the complete shaft must be replaced. An exchange system operates in respect of this part.

To replace the front main bearing, take the crankshaft from the engine and remove the bearing by applying a puller tool on the ball bearing inner race. When fitting the new bearing utilise the threaded stub and nut on the crankshaft by inserting spacer and spacing washers under the nut and forcing the bearing into place bit by bit.

### IMPORTANT

Do not fit the bearing with an arbor press since this might spoil the alignment of the crankshaft. Main bearings are specially made, with a particular clearance, and only genuine Saab spare parts should be used. Note — the standard SKF bearing with the same designation is not suitable.

### REPLACEMENT OF CLUTCH SHAFT BUSHING

If cleaning shows that the bushing is damaged or play is excessive then it must be replaced. The play in this bushing has a great effect on the life of the clutch shaft seals and must not exceed 0.001 in. (0.04 mm).

When removing the old bushing use a 5/8 in. (16 mm) screw tap with a steel ball in the bottom. Continued turning after the tap has bottomed will cause the bushing to be slowly ejected.



## FLYWHEEL

### REPLACEMENT OF RING GEAR

To replace the flywheel ring gear lift the engine out of the car and remove the flywheel. Note that the rear main bearing is exposed by the bolt holes when the flywheel bolts are removed. Take care to prevent foreign particles from entering the bearing. Remove the old ring gear by drilling a  $\frac{3}{16}$  in. (5 mm) hole through the gear from rear side, and then splitting it with a cold chisel. The new ring gear must be heated to about  $390^{\circ}$  F ( $200^{\circ}$  C) for fitting. This can be done in an ordinary kitchen oven. If done with a gas torch it is most important that the flame is kept in motion — not allowed to rest at any one point of the gear.

After heating, place the gear on the cold flywheel with the chamfer on the teeth uppermost. Be sure that the ring gear is firmly seated on the flywheel. Do not hammer the heated ring gear.

### GRINDING OR MACHINING OF FLYWHEEL

These jobs may be required if the flywheel clutch face shows burning or scoring. It is permissible to machine off 0.02 in. (0.5 mm). Deeper scoring will entail replacement of the flywheel.

#### NOTE.

In principle, all machining of the flywheel requires corresponding machining of the clutch facing to preserve the correct relationship between flywheel and clutch.

### REASSEMBLY OF FLYWHEEL

Note that flywheel bolts are of special material, and standard bolts are not to be used.

Always use a new lockwasher when reassembling the flywheel. Remember that the bolts must be torqued to 19–24 ft-lb. (2.7–3.3 kpm).

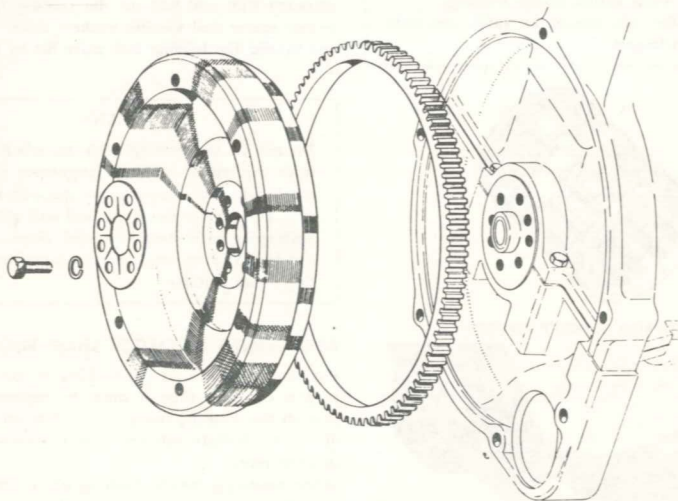

Flywheel and ring gear.



## DISTRIBUTOR DRIVE AND VIBRATION DAMPER

### GENERAL

The distributor gear housing consists of an extension to the crankcase at the engine front end. It is lubricated by chassis grease and is a completely sealed-off compartment, with double seals on the crankcase side and a single sealing ring at the front, where the pulley is fitted. See fig.

The distributor drive pinion is located between the inner and outer covers. The engaging gear on the distributor must also be replaced when the crankshaft pinion is replaced —

If grease is ejected from the plastic vent hose or

if compressed air from the crankcase leaks out at the crankshaft pulley then one or more of the seals is damaged and must be replaced.

The covers are held in place by a retainer ring with shims under. These shims are available in two thicknesses, viz. 0.012 and 0.02 in. (0.3 and 0.5 mm).

It is important that the retainer is correctly located in its groove and that shimming is correct. Hard shimming may cause the retainer to jump free, slack shimming may give rise to noise trouble.

In order to increase the strength of the hub of the crankshaft pulley, the diameter of the hub has been increased from 25 mm (0.985 in.) to 30 mm (1.18 in.) on later cars. This modification has brought about alteration of sealing ring and of outer cover as well. When replacing these parts always make absolutely sure to get parts that fit each others. Spring and sleeve for the vibration damper are matched — thus, when replacing, same should be installed together.

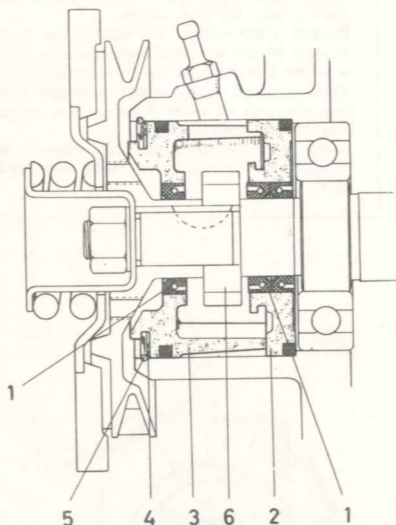

Distributor drive with seals; and crankshaft pulley with vibration damper.

1. Seal rings
2. Inner cover
3. Outer cover
4. Shims
5. Retainer ring
6. Distributor drive pinion

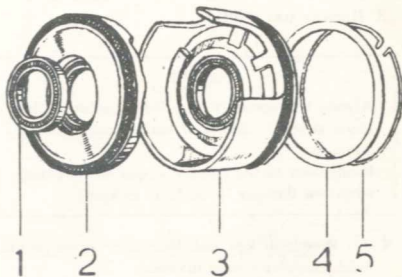

Seals in distributor gear housing.

1. Sealing ring
2. Inner cover with sealing ring and O-ring
3. Outer cover with sealing ring and O-ring
4. Shims
5. Retainer ring





## DISASSEMBLY

1. Disconnect battery ground cable.
2. Remove hood by:
  - a) disconnecting cables to lamps and horns, radiator blind chain and hood stopper
  - b) moving hood to rear and upwards until it slips off hinge pins.
3. Remove generator and fan belt.
4. Back off nut retaining crankshaft pulley, remove pulley and vibration damper. Use puller 784055 if necessary.
5. Back off distributor clamp screw and pull up approx. 1 in. (25 mm).
6. Remove retainer and shims from outer gear casing cover.
7. Remove outer cover, using puller 784054. See fig.
8. Remove distributor drive pinion with puller 784051.
9. Collect Woodruff key.
10. Remove inner cover with sealing rings and O-ring, using tool 784056.

## REASSEMBLY

1. Fit assembly tool 784056 on crankshaft with larger end innermost.
2. Grease inner cover, including sealing rings and O-ring, and insert in place. Check that cut-out in cover coincides with hole for distributor.
3. Remove tool 784056.

### NOTE.

Always use assembly tool 784056 when fitting inner cover — otherwise sealing rings will be damaged.

Remember to use correct torque when fitting vibration damper — 36 ft-lb. (5 kpm).

4. Fit Woodruff key and distributor drive pinion, with chamfer facing inwards.
5. Fit outer cover with its sealing ring and O-ring so that marking on cover coincides with that on engine block. See fig.
6. Press outer cover into position by screwing tool 784057 on crankshaft stub.
7. Insert a suitable combination of shims.
8. Fit retainer, making sure that it seats properly in its groove.
9. Back off tool between 1/4 and 1/2 turn and check that shims are up against retainer — if not, retainer must be removed and more shims inserted.
10. Remove tool 784057 from crankshaft.

11. Fit pulley on shaft.
12. Fit vibration damper, remembering lock washer under nut. Torque 36 ft-lb. (5 kpm).
13. Refit distributor. See Chapter 15 concerning ignition timing.
14. Refit fan belt and adjust tension.
15. Refit hood and hood stopper, reconnect lamp and horn cables and blind chain.
16. Reconnect battery ground cable.
17. Check that lamps and horns function correctly.
18. Grease distributor gear until excess grease is forced out through plastic vent hose.
19. Test engine.

### NOTE!

When reassembling see to it that pulley and sealing ring fit each others.

Reason: from engine No. 153688 the Saab 95 and 96 are equipped with a pulley with a larger hub diameter (ø 30 mm=1.18 in.). This, in turn, brings about a larger sealing ring and an outer cover with a larger hole for the sealing ring.

When replacing pulley in older cars, it is to advantage to install the parts mentioned above.

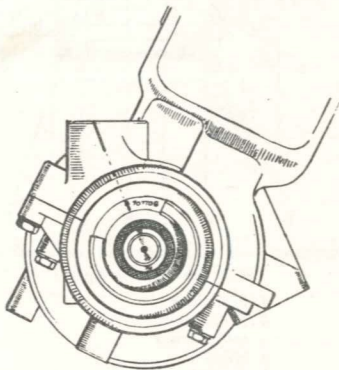

Marking of cover for distributor gear casing.





## REMOVAL AND INSTALLATION

### REMOVAL

1. Remove engine from car — see Chapter 3.
2. Back off six bolts holding pressure plate assy. to flywheel. Release bolts gradually, placing spacers (tool No. 784065) under clutch levers — see fig.
3. Remove pressure plate assy. and clutch disc.

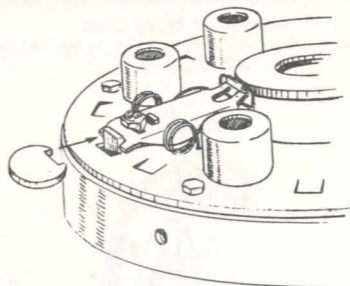

Placing of spacers No. 784065 when removing or installing clutch pressure plate assy.

### INSTALLATION

1. Insert clutch disc and refit pressure plate assy. to flywheel, using spacers No. 784065 to ensure that locating tongues guide assembly into correct position against flywheel.

#### NOTE

If flywheel and clutch combinations have been mutually balanced this is indicated by color markings. To ensure that they correctly balance on another when reassembled locate color markings as close to 180° apart as hole spacing permits. Unmarked parts may be re-assembled in any position, or in same position as before.

2. Center clutch disc with tool No. 784064, which fits into clutch-shaft bearing at the crankshaft end.
3. Tighten the six pressure plate bolts gradually and collect clutch lever spacers.

#### NOTE

Check clutch shaft seal before refitting engine in car. Afterwards, apply a little graphite grease to shaft splines.

4. Install engine as described in Chapter 3.

### DISASSEMBLY

Before disassembling pressure plate assy. mark all parts to ensure reassembly in same relative positions. This is important for retention of clutch balance.

1. Using a hack saw, remove the locking of the nuts of the clutch lever adjustment screws, see fig.
2. Back out adjustment screws successively, after which entire pressure plate assy. can be disassembled.
3. Inspect and check all parts, including coil springs, which should conform to following requirements:

Length, uncompressed	1.95 in. (49.5 mm)
„ compressed	1.16 in. (29.4 mm.)
Tension	108—115 lb. (49—52 kg.)
Min. permissible tension	100 lb. (45 kg.)

### REASSEMBLY

1. Smear clutch lever friction surfaces very lightly with graphite grease.
2. Insert coil springs in cups and locate latter in cover plate
3. Fit pressure plate in position and secure clutch levers with adjustment screws. Use new nuts with undamaged locking flange. If old screws have been damaged during disassembly, fit new ones.
4. Attach release plate with the fork springs, and place spacers No. 784065 under clutch levers, see fig.
5. Check that clutch disc is in good condition, refit pressure plate assy. to flywheel and tighten six retaining bolts successively, removing spacers. Center the clutch shaft with tool No. 784064
6. Place a steel rule against release plate: distance from edge of rule to upper surface of flywheel should be 1 in. (25 mm.) when clutch disc is new, see fig. It is important that this distance is the same all round, otherwise the release plate will ride skew. Adjust release plate alignment with adjustment screws.
7. Depress release plate a few times and re-measure.
8. After final adjustment secure adjustment screws by bending in nut flange.



## CLUTCH DISC

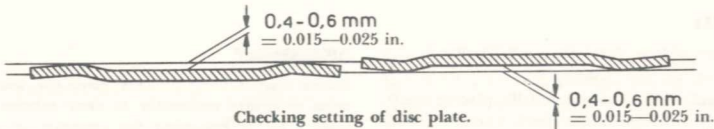

## CHECK OF CLUTCH AND REPLACEMENT OF FACINGS

1. Inspect clutch face of flywheel for damage: burning or minor scratches are not so important but deep scoring indicates need to machine flywheel face or install new flywheel. See description in Chapter 3.
2. Check pressure plate for scores or skewness. If surface is uneven, replace with a new pressure plate, or possibly, machine down the old one.
3. Remove release plate and check clutch levers for wear.
4. Check that release plate is undamaged. Damage might occur if release-bearing graphite ring is badly worn.
5. Inspect release bearing, particularly graphite ring. If ring is worn down to level of its retainer, the bearing must be replaced.
6. Inspect clutch disc for wear and reface if necessary.
7. Before refacing check disc plate setting and adjust if necessary. All twelve segments must have identical setting, which should be between 0.015—0.025 in. (0.4—0.6 mm). — see fig.
8. Locate rivets as shown in appropriate figure. It is necessary to check clutch disc for skewness after new facings have been fitted. Throw may not exceed normal play by more than 0.02 in. (0.5 mm). Check with a dial indicator between arbors. See fig.

## NOTE

A special clutch facing is supplied for the GT-750. See Spare Part List.



## Location of facing rivets

Thickness of a new, unloaded disc = 9,1—9,4 mm  
(0,36—0,37 in.)

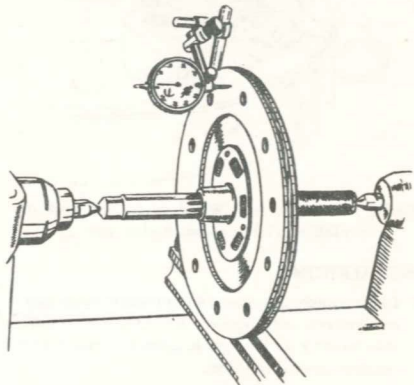

Checking throw of clutch disc

## RELEASE BEARING

## REMOVAL AND INSTALLATION

1. Remove engine from car as described in Chapter 3.
2. Bend release fork forward and remove two spring clips retaining release bearing in fork.
3. Remove release bearing.

After replacement of bearing, refit in reverse order. If graphite ring is worn level with its retainer the bearing must be replaced.

## IMPORTANT

Always check that spring clips are correctly attached.



**DESCRIPTION**

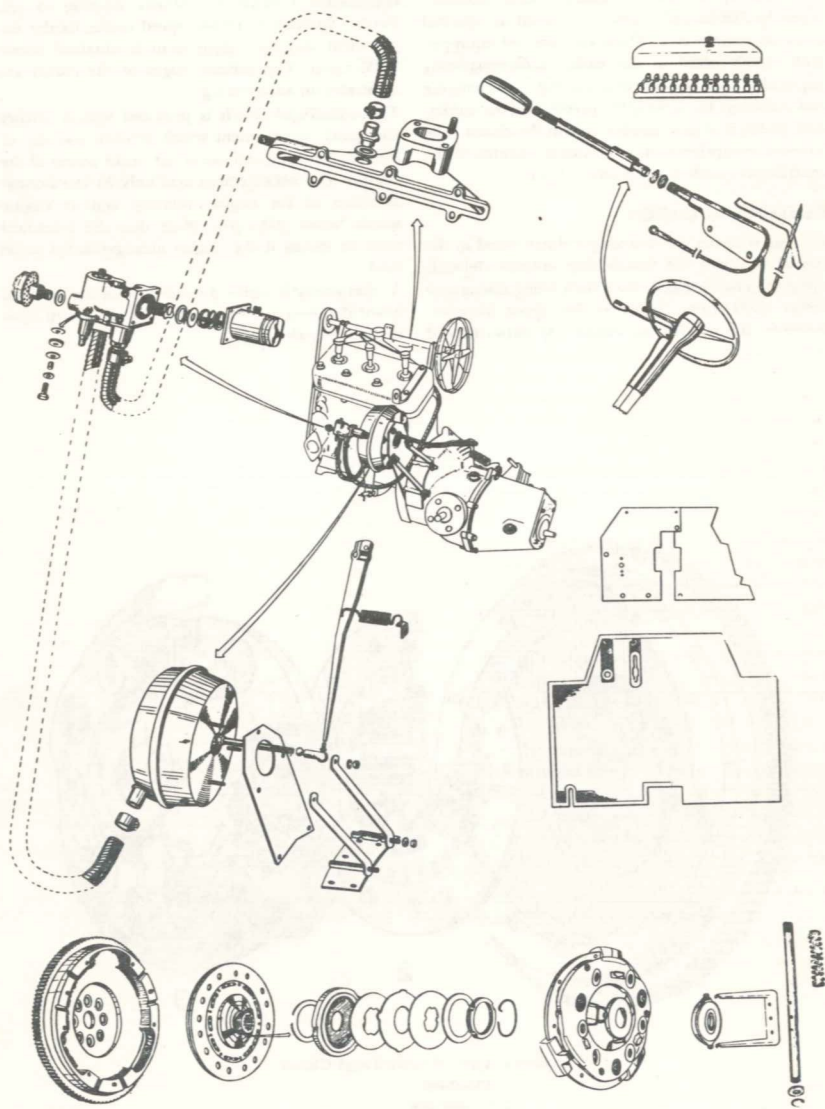

Parts of the SAXOMAT clutch. See also SAAB Spare Part List.



## GENERAL

The SAXOMAT FL automatic clutch, manufactured by Fichtel and Sachs, is supplied as optional extra on certain cars. These cars are not equipped with clutch pedal as the clutch is automatically engaged or disengaged when starting, gear-changing and stopping. By varying the pressure on the accelerator pedal, it is also possible to slip the clutch. The Saxomat comprises two independent assemblies: the centrifugal clutch and the servo clutch.

## CENTRIFUGAL CLUTCH

Fig. below shows the centrifugal clutch fitted in the special flywheel. Its functioning entirely depends upon the engine speed, the clutch being disengaged below 1,000 r.p.m. As the engine speed increases, however, the centrifugal weights fly outwards and

engagement commences, though slipping as yet. Further increase in engine speed causes harder engagement and full engagement is obtained above 1,800 r.p.m. The various stages of the clutch are illustrated in adjacent fig.

The centrifugal clutch is provided with a ratchet and pawl arrangement which permits starting of the car by towing and use of the brake power of the engine. The arrangement acts only in the normal direction of the engine rotation and at engine speeds below 300 r.p.m. Note that the freewheel must be locked if the ratchet arrangement is to be used.

A characteristic noise due to this device will be heard if the engine stops while the car is still moving, i.e. freewheeling.

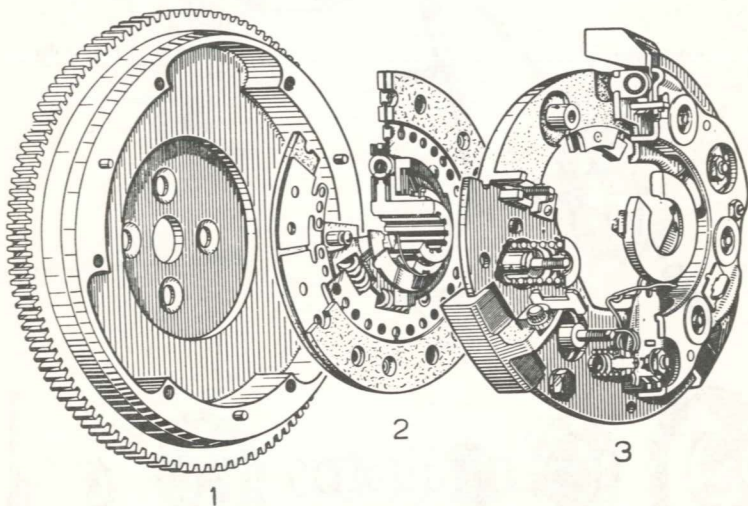

Sectioned View of Centrifugal Clutch.

1. Flywheel
2. Clutch disc
3. Pressure plate assembly



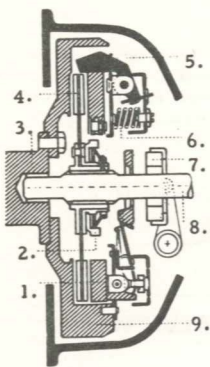

A. When engine is idling or at standstill weights are at inner position and clutch is released.

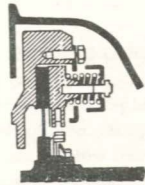
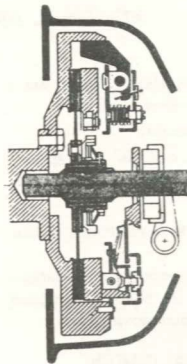
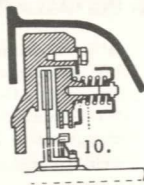

C. At about 1,800 r.p.m. weights are fully extended and clutch is completely engaged.

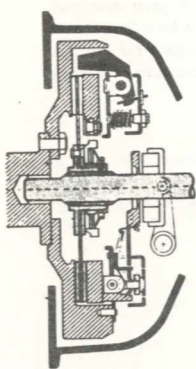

B. At engine speed of about 1,000 r.p.m. clutch begins to engage.

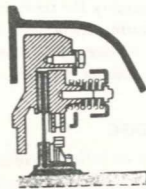

Functioning of centrifugal clutch

1. Clutch
2. Ratchet wheel
3. Crankshaft
4. Clutch disc
5. Centrifugal weight
6. Spring for centrifugal weight
7. Release bearing
8. Clutch shaft
9. Flywheel
10. Main spring

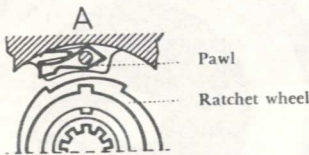

A. At idling or higher speeds pawls are disengaged.

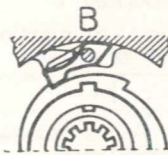

B. When engine is at standstill or turning only very slowly (below 300 r.p.m.) pawls are engaged.

Ratchet and pawl arrangement





## REMOVAL AND INSTALLATION

### ORDERING OF PARTS

Saab cars fitted with the SAXOMAT clutch have a modified power unit, in that they have:

1. Completely new clutch assembly.
2. Flywheel with recesses for centrifugal weights.
3. Inlet manifold provided with connection for vacuum power unit.
4. Clutch cover adapted for Saxomat clutch mechanism.

When ordering any of the above parts be careful to specify the correct part for Saxomat-equipped cars. Use only genuine Saxomat service parts.

### REMOVAL OF CENTRIFUGAL CLUTCH

1. Lift engine from car, see Chapter 3.
2. Back off six bolts securing pressure plate assy. to flywheel.
3. Remove pressure plate assy. and disc.

### INSTALLATION OF CENTRIFUGAL CLUTCH

Before installing clutch assy. check that disc moves easily on clutch shaft splines, yet does not have excessive clearance. Smear shaft lightly with an oil/graphite mixture — excessive lubrication may cause undesirable splash on to clutch facings. Check also shaft seal in transmission case.

1. Place clutch disc against pressure plate, checking that pawls in pressure plate assy. engage with disc ratchet wheel, see fig.

#### WARNING

If correct engagement is not secured the pawls will be damaged during installation.

2. Fit complete clutch assy. to flywheel, locating disc with aid of aligning arbor 784064. Be careful not to damage pawls.
3. Clutch should be located by flywheel locating studs. Tighten the six bolts successively. When installed the clutch weights will be at their inner positions, corresponding to declutched condition, and no pressure need be overcome during installation. Thus, the spacer discs for the clutch levers may be dispensed with. It is important that the disc be correctly aligned.

After installation it should be easy to turn clutch disc against normal engine rotation. Turning in the normal direction of rotation, on the other hand, causes the flywheel to rotate also, due to engagement of ratchet device.

4. Reinstall engine in car.
5. Adjust clutch release bearing, see Sect. 13.
6. Test car, adjusting servo pilot valve and gear-lever switch contact-gap as necessary.

## CENTRIFUGAL CLUTCH

### PRESSURE PLATE ASSEMBLY

Special equipment is required for the correct reassembly and adjustment of the pressure plate assy., and disassembly for replacement of parts or adjustment of spring tension should not be attempted. If damaged replace entire assy. or return for reconditioning to the local agents of the makers, Fichtel & Sachs.

### CLUTCH DISC

Clutch disc or facings may be replaced after lifting engine from car and removing clutch assy., as described in Section 11. A special type of clutch facing is provided for the Saxomat.

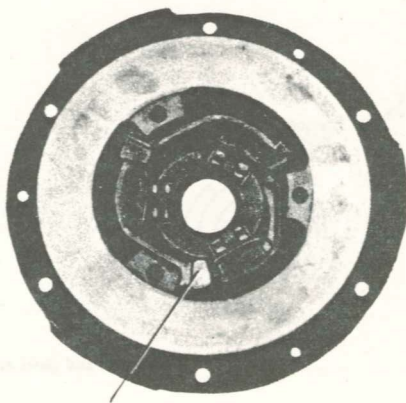



## SERVO UNIT

### VACUUM POWER CHAMBER

Replace damaged parts if any leak from the power chamber diaphragm or the connection pipes is observed. Check the linkage rod free movement as follows when a new vacuum power chamber is fitted.

### BASIC ADJUSTMENT OF RELEASE BEARING CLEARANCE

The following adjustment of the release bearing clearance must be made after that a new centrifugal clutch or vacuum power chamber has been fitted.

Since the clutch disengages when the engine is idling or stopped, the servo release lever must be

mounted on the clutch shaft splines so that its travel is not interrupted by the transmission case. Check this by moving the lever forward as far as it will go, when there should still be clearance between the lever and the case. Simultaneously, press the linkage rod right in to the vacuum power chamber and check relationship between the lever ball end and the ball seat in the end of the linkage rod — the centre of the lever ball should lie 0.08–0.12 in. (2–3 mm.) in front of the linkage rod seat, see fig. Adjust by changing linkage rod length, remembering to tighten the locknut on the linkage rod end afterwards.

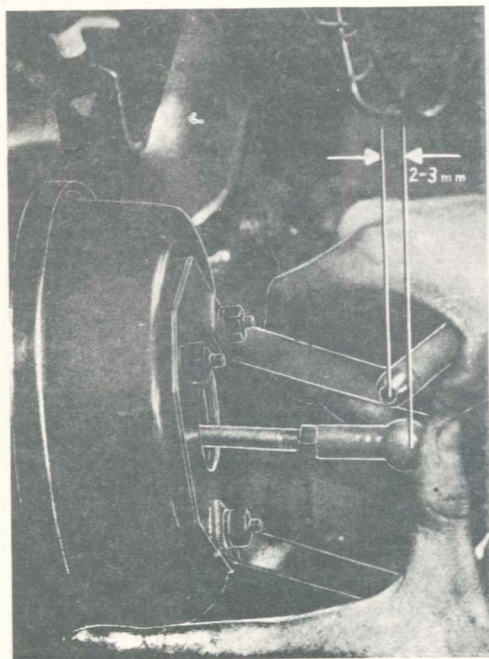

Adjusting linkage rod  
Adjustment of length  
is necessary before connecting to clutch servo release lever after fitting of new clutch unit.



## CHECK AND ADJUSTMENT OF RELEASE BEARING CLEARANCE

Clearance between the release bearing and the release plate is to be checked and adjusted regularly. In the case of conventional clutches this is checked at the clutch pedal, but cars fitted with SAXOMAT have no pedal and the clearance must be checked at the outer end of the servo release lever or linkage rod. It is also possible to open the inspection plate above the release bearing and estimate clearance between the bearing and the plate, which should be 0.08—0.12 in. (2—3 mm) at engine speeds exceeding 2,000 r.p.m. (i.e. when the centrifugal weights are fully extended). This corresponds to a movement of

7/16—1/2 in. (9—13 mm) at the outer end of the lever, see fig. Adjust release bearing clearance by disconnecting linkage rod from lever and altering linkage rod lengths as requisite. Remember to secure locknut on linkage rod end after adjustment.

### NOTE

Run engine at a speed of about 2,000 r.p.m. to ensure that the centrifugal weights are fully extended when clearance is checked.

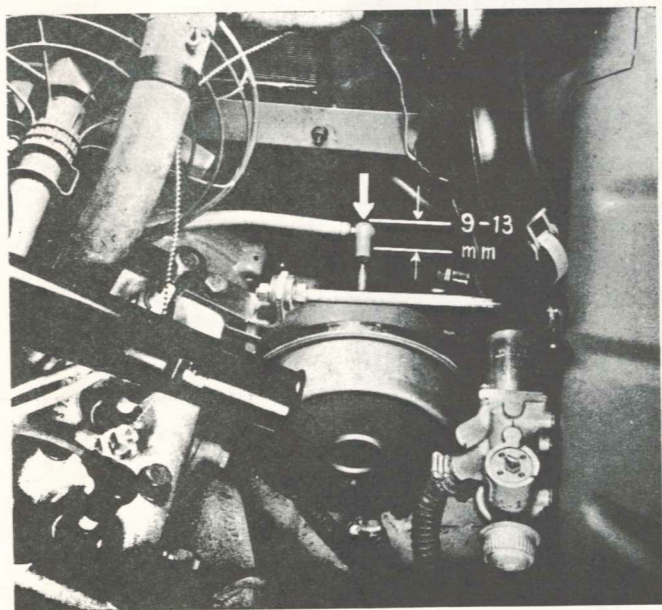

Checking release bearing clearance by measurement at outer end of servo lever.





### PILOT VALVE

The pilot valve assy. comprises a solenoid and valve body containing valves and connections for the vacuum pipes. The pilot valve assy. may be described as the brain of the servo system and should be adjusted with great care.

The valve is attached by three bolts to the inside of the left front wheel house. These should not be tightened excessively, or the rubber bushings will lose their resilience. Check the vacuum pipes for correct connection and absence of leakage. Connection of electric cables to the valve is arbitrary, since the functioning of solenoid and valve is not dependent on direction of current.

It is very seldom necessary to disassemble the pilot valve, but if such need arises no great difficulties are encountered. Adjustment after reassembly will be easier if the position of adjustment screws is left unchanged. The accompanying illustration shows the arrangement of the pilot valve. Two ways of adjustments are possible: of the reduction valve and of clutch-engagement delay.

### REDUCTION VALVE

Adjust the reduction valve by means of screw 1 on the upper side of the valve body. The reduction valve determines the fierceness of clutch engagement if the accelerator is not depressed immediately when car is moving. Tightening

the screw gives a more gentle engagement, and vice versa. A fine adjustment, to compensate for clutch wear during running-in, may be needed after the first 600—1200 miles (1,000—2,000 km.). The easiest way to test clutch fierceness is to drive the car and make quick changes from 1st to 2nd gear without depressing the accelerator afterwards. Adjust the reduction valve to achieve a gentle and pleasant engagement action, so that the engine gives full traction after about 3 seconds, momentarily causing an increase in road speed. See also Section ADJUSTMENT OF PILOT VALVE.

### DELAY OF CLUTCH ENGAGEMENT

The tension of the spring retaining the pressure-equalizing diaphragm may be adjusted by means of screw 2, on the valve body underside. This adjustment governs the speed of clutch engagement, if the accelerator pedal is depressed immediately after a gear change in motion. However, it is very seldom that this screw need be adjusted. Tightening of the screw gives a sooner engagement and vice versa. The clutch should engage practically immediately if the accelerator is depressed after a change from, for example, 2nd to 3rd gear at moderate speed. If the engine races before the clutch engages, and if the reduction valve is properly adjusted and the system correct in all other respects, this screw may be adjusted to counteract such racing. See also Section ADJUSTMENT OF PILOT VALVE.

### GEAR LEVER

#### ADJUSTMENT OF SWITCH CONTACTS

Correct point gap for the contacts of the gear-lever switch should be 0.006—0.008 in., (0.15—0.20 mm.), see fig. To adjust, release lock washer and back off lock nut. Correct point gap is secured if the sleeve nut is tightened fully and then backed off 1/4 turn. During this check, check also that contact surfaces are smooth and free from deposits. After adjustment secure the sleeve nut with locknut and lock washer. Take care not to damage the lock washer when tightening the locknut.

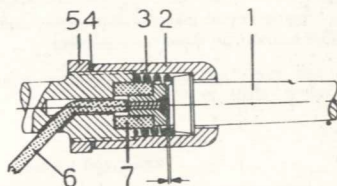

0.006—0.008 in. (0.15—0.20 mm.)

- Contacts in gear-lever switch
- |                |               |
|----------------|---------------|
| 1. Gear lever  | 5. Locknut    |
| 2. Sleeve nut  | 6. Cable      |
| 3. Spring      | 7. Insulation |
| 4. Lock washer |               |



## ADJUSTMENT OF PILOT VALVE

Pilot valves supplied by the factory are already correctly adjusted but may need fine adjustment after fitting and the car should be given a test run to check this, see below. Shop-disassembled valves, however, will first require basic adjustment as follows.

Do not adjust screws more than one turn at a time without first driving car to check results.

### BASIC ADJUSTMENT

1. Back off lower adjustment screw and tighten upper screw, until both reach stop positions.
2. Screw in lower screw until clutch functions if accelerator is depressed immediately after gear change in motion.
3. Back off upper screw about 5 turns, until clutch engages gently after some 3 sec. when changing gear in motion without depressing accelerator pedal afterwards.

Continue with fine adjustments, as follows.

### FINE ADJUSTMENT

After basic adjustment, or after fitting a factory-tested pilot valve, test the car as follows:

- A. Accelerate to approximately 20 m.p.h. (30 km/h.) in 1st gear and change smartly to 2nd. Release gear lever without depressing accelerator pedal afterwards. When clutch engages, after some 3 sec., engine should take the load gently and increase actual road speed for a moment.

If a test run does not satisfy adjust screw I (reduction valve) as follows:

Fault	Cause and Remedy
I. Speed increase not noticeable or delayed.	Power chamber vacuum reduced too slowly: <b>Back off screw 1 turn</b>
II. Fierce clutch engagement causes car to jump.	Power chamber vacuum reduced too quickly: <b>Tighten screw 1 turn</b>

For a very fine adjustment the screw may be moved only half a turn, but never more than one turn without first checking result by a test run.

- B. Drive car in 2nd gear at about 25 m.p.h. (40 km/h.). Change to 3rd gear and accelerate hard. Clutch should engage practically immediately, engine r.p.m. increasing slowly as the car increases the speed.

If the test does not give this result, adjust screw 2 (pressure equalizing diaphragm) as follows. (Adjustment of this screw is exceptional and should be undertaken only when reduction valve is correctly set and no other cause of slipping clutch may be suspected).

Fault	Cause and Remedy
Engine speed increases abnormally, adjusting to road speed after a short interval.	Vacuum in power chamber reduced too slowly when accelerator is depressed after change: <b>Tighten screw 1/2 turn.</b>

If fine adjustment as described above does not give fully satisfactory results, and the system is otherwise without fault, replace the pilot valve.

### NOTE

Always adjust upper adjustment screw first. Do not omit to secure screws after adjustment.





## DESCRIPTION

### GENERAL

Transmissions for the Saab 95, 96 and GT 750 are designed for front-wheel drive and arranged so that all shafts with their gears, freewheel, differential and inner universal joints form a complete unit.

The Saab 96 is fitted with a 3-speed transmission with synchromesh on 2nd and 3rd gears. The 1st speed has a dog clutch and the reverse gear is sliding. The Saab 95 and GT 750 both have 4-speed gear boxes differing from each other only in respect of the pinion/crown wheel ratios. All forward gears in the 4-speed gear box have synchromesh, while reverse gear is a sliding wheel.

The 3 and 4-speed gear boxes do not differ greatly in outward respects and the trains are

arranged in a similar manner, with an input clutch shaft, freewheel, main shaft, countershaft, pinion shaft, differential and inner universal joints. Certain parts, such as the freewheel and differential case, are similar in both. The shafts are carried in ball bearings in the gear box casing. The connection to the engine is through a light alloy clutch housing, which also encloses the differential. All gears are helical cut and in constant mesh, except the reverse gear. Shaft-borne gears are carried on needle bearings. The synchronizer unit is located on the main shaft in the 3-speed unit, while there are synchronizer units on both main and countershaft in the 4-speed unit.

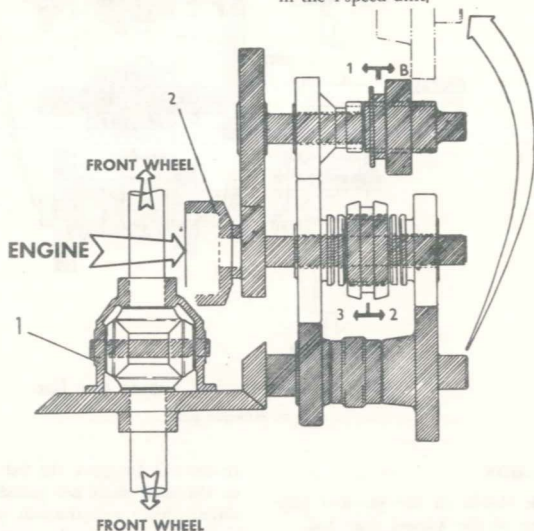

Diagrammatic arrangement of 3-speed gear box

1. Differential case
2. Freewheel sleeve
- B. Reverse gear

Gear-changing motions are transmitted from the steering column lever to two forks in the 3-speed gear box and to 3 forks in the 4-speed gear-box. These forks are able to slide on their respective rails and are located in the correct gear positions by spring-loaded poppet balls, which fit into appropriate recess in the rails. An arrangement is also provided which renders it impossible for the driver to engage two gears simultaneously.

### 3-SPEED GEAR BOX

The diagrammatic sketch on the previous page shows the working of the 3-speed gear box.

In 1st gear power is transmitted by the pinion immediately behind the freewheel on the main shaft to the countershaft gear. The 1st speed gear on the countershaft is in constant mesh with the 3rd speed gear on the main shaft. Thus when the 1st gear is locked to the countershaft by its dog



clutch, power is transmitted to the pinion shaft via the 3rd speed gear, which in this case acts as an intermediary idler.

In 2nd gear power is transmitted direct from the main shaft to the pinion shaft by locking the 2nd speed gear to the main shaft, by means of a sliding sleeve.

In 3rd gear power is transmitted to the pinion shaft in the same manner as in 2nd gear, except that the sliding sleeve now locks the 3rd speed gear to the main shaft. For reverse, power is transmitted to the countershaft by way of the pinion and countershaft gear mentioned in connection with 1st gear; above. The reverse gear is splined on the countershaft and, when it slides into mesh with the pinion shaft second-and-reverse gear, power is transmitted to the pinion shaft, but in reversed rotation. The reverse gear hub acts also as an engaging sleeve for the 1st speed gear.

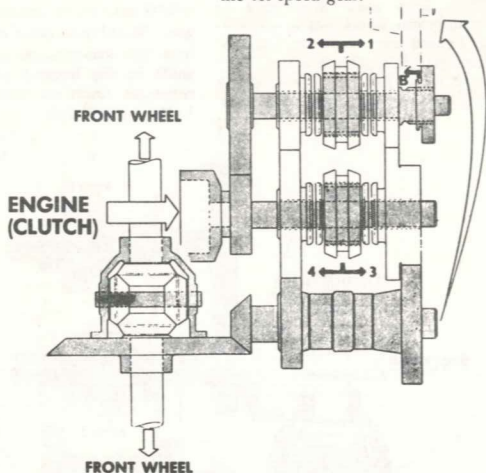

Diagrammatic arrangement of 4-speed gear box

B = Reverse gear

#### 4-SPEED GEAR BOX

The diagrammatic sketch on the previous page shows the working of the 4-speed gear box. As with the 3-speed gear box, in 1st gear power is transmitted to the countershaft via the pinion and gear behind the freewheel. The otherwise free-turning 1st speed gear is locked to the countershaft by a sliding sleeve, power then being transmitted to the 3rd speed gear on the main shaft and thence to the pinion shaft 3rd gear and reverse gear. In 2nd gear power is transmitted in a similar manner to that in 1st gear, except that the sliding sleeve locks the 2nd speed gear to the countershaft, power reaching the pinion shaft 4th gear via the 4th speed gear on the main shaft. Thus, in both 1st and 2nd gears, the main shaft wheels act purely as intermediary idlers.

In 3rd and 4th gears, the 3rd and 4th speed gears on the main shaft are locked to the shaft by a sliding sleeve and transmit power direct to the appropriate gear on the pinion shaft. In reverse, power is transmitted from the main shaft to the countershaft over the pinion and gear behind the freewheel. The reverse gear, splined on the countershaft, slides into direct engagement with the pinion shaft 3rd-and-reverse gear, whereby the pinion shaft is turned, but in reversed direction.

#### SYNCHROMESH

The synchronizer units in the 3-speed and 4-speed gear boxes are similar in principle and such a unit is illustrated here. It acts as follows: To engage, for example, 3rd gear it is necessary to bring the dog ring on the 3rd speed gear into engagement with the internal teeth of the synchronizer sleeve. As the sleeve is moved towards the gear it

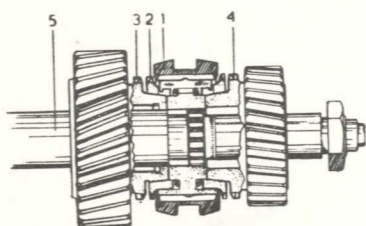

#### Synchronizer unit

1. Synchronizer sleeve
2. Bronze blocking ring
3. Dog ring, 3rd speed gear
4. Dog ring, 2nd speed gear
5. Primary shaft

pushes before it a bronze blocking ring which has an internal taper and external teeth corresponding to those of the gear dog ring. The sleeve and blocking ring rotate at the same speed as the shaft, but the blocking ring is able to shift its position relative to the sleeve by half a tooth pitch. If the speed of the 3rd speed gear is different to that of the sleeve when engagement commences, the teeth on the blocking ring will prevent the internal sleeve teeth from engaging the gear dog teeth. The internal taper of the blocking ring is forced over the 3rd gear cone and, through friction, the gear and sleeve will be synchronized to the same speed. The path for the sleeve is then freed by the blocking ring, and the sleeve teeth can engage the dog ring on the gear.

#### FREEWHEEL

The freewheel transmits power from the transmission shaft to the transmission case main shaft. The freewheel hub, which is splined on the clutch shaft, has six roller cam recesses each containing a roller. Individual coil springs constantly endeavour to press the rollers into the wedge formed by the cam recess and the surrounding roller race comprised by the freewheel sleeve, which is integral with the main shaft.

When driving torque is applied to the hub through the crankshaft and clutch shaft, the hub will tend to rotate faster than the main shaft and the rollers will be forced hard up into the wedge space formed by the cam recesses, causing the freewheel to engage. The main shaft is now forced to rotate at the same speed as the clutch shaft, with which it is virtually united.

As soon as the main shaft tends to run faster than the clutch shaft, as when going downhill without acceleration, the freewheel sleeve will turn the rollers back into the cam recesses and thereby release the engagement. The sleeve (i.e. the main shaft) is thus free to turn faster than the clutch shaft.

A blocking device permits total locking of the freewheel.

#### SPEEDOMETER DRIVE AND DIFFERENTIAL

The speedometer drive is taken from the pinion shaft in the transmission case, through a worm gear and connection to the speedometer cable.

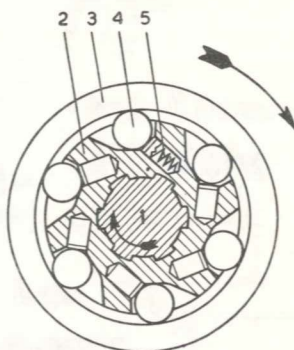

Diagrammatic arrangement of freewheel

1. Clutch shaft
2. Freewheel hub
3. Freewheel sleeve
4. Roller
5. Coil spring

The differential comprises two differential gears and two side gears, one for each front drive shaft. These gear wheels are of plain bevel type. The side gears are splined on stubs and turn the inner drive shafts through universal joints. The crown wheel, to which the pinion gear transmits the transmission torque, is bolted to the differential case.

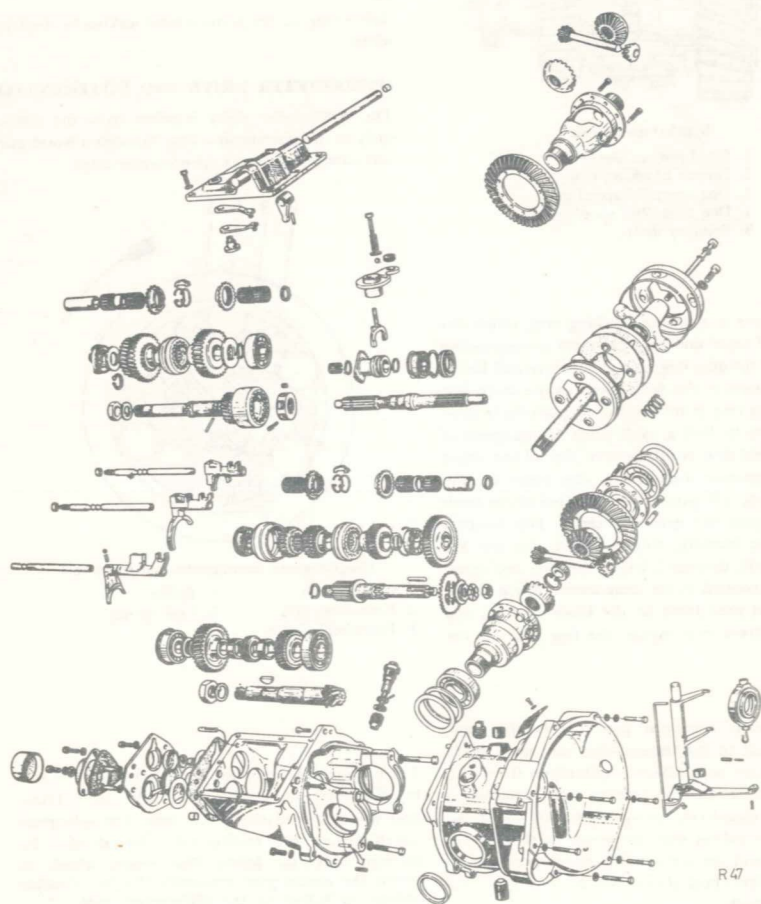

4-speed gear box





## REMOVAL AND INSTALLATION

### REMOVAL

To remove the transmission unit from the vehicle it is necessary to lift out the entire power unit.

1. Disconnect battery ground cable at engine and battery.
2. Remove hood by
  - a) disconnecting cables to lamps and horns, radiator blind chain and hood stopper,
  - b) moving hood to rear and upwards until it slips off hinge pins.

### IMPORTANT

Always remove hood immediately stoppers are released — if supported only by prop, it may be knocked accidentally to the floor.

3. Drain cooling system and transmission if necessary.
4. Remove induction muffler with cleaner and preheater.
5. Disconnect fuel hose, throttle linkage and cold start control from carburetor.
6. Disconnect starter controls.

7. Disconnect muffler suspension, see fig.
8. Disconnect muffler pipe and exhaust pipe clamp from exhaust manifold.
9. Disconnect both engine front supports from body — all six bolts are accessible from under engine space floor pan.
10. Disconnect clutch cable from engine assembly by releasing cable tension and unhooking cable from eye under engine.
11. Disconnect engine side stay.
12. Disconnect speedo. cable and freewheel control from transmission.
13. Disconnect generator cables and distributor primary cable (adjacent).
14. Unscrew water temperature-gauge sending unit.
15. Disconnect water outlet hose from engine.
16. Disconnect water inlet hose at pump.
17. Remove r. h. toeboard after turning back rubber mats, and release power unit rear support bolt. If stud should be difficult to release from support, tap cautiously in a sideways direction with an arbor inserted in support taper tube.
18. Jack up front of car and remove right front wheel on a l.h.-drive car. On a r.h.-drive car remove the left front wheel.
19. Release upper ball joint on the R. H. side by removing the two bolts which retain the steering arm and the ball joint to steering knuckle. NOTE! on the other hand, on a R. H. D. car the L. H. side ball joint shall be released.
20. Pull steering knuckle outwards to release shaft from inner universal joint

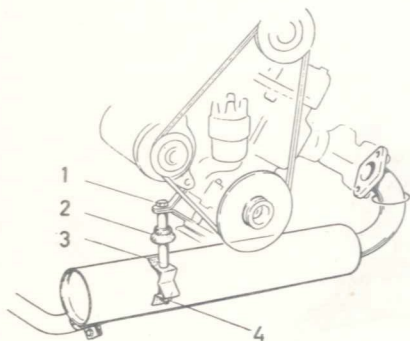

Front muffler

1. Bolt
2. Rubber sealing
3. Spacer tube
4. Nut and spring washer

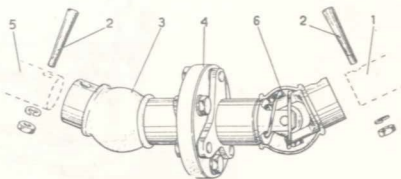

Gear shift shaft joint, L. H. D. car

1. Gear shift shaft
2. Taper pin with lock nut
3. Rubber bellow
4. Hardy disc
5. Gear shift operating rod
6. Spring





20. Pull outwards on steering knuckle to release shaft from inner universal joint.
21. Release gear shift shaft from joint in engine space by removing taper pin, see fig. Use the tool 784083.
22. Fit lift hook 784058 and lift entire power unit from car, see fig. below. Clean unit and separate transmission from engine.

### INSTALLATION

1. Reassemble engine, transmission and starter and lift unit into car with hook 784058, guiding drive shaft into inner universal joint.
2. Insert the disconnected drive shaft into inner universal joint.
3. Join steering arm and ball joint to steering knuckle.
4. Remove lifting hook.
5. Refit front wheel and lower car to floor.
6. Secure rear engine support.
7. Secure front engine supports.
8. Reconnect freewheel control to operating lever on transmission.
9. Reconnect speedo. cable to gear box.
10. Reconnect gear shift shaft joint and lock taper pin. Do not omit spring on shaft, between joint and dash panel.
11. Reconnect lower cooling water hose to pump.
12. Reconnect ground cable to engine.
13. Reconnect throttle linkage bellows and cold starter control to carburetor.
14. Reconnect starter cable and controls.
15. Reconnect generator and distributor primary cables.
16. Reconnect fuel hose to carburetor.
17. Reconnect ignition cables to distributor.
18. Refit engine side stay.
19. Screw in temp. gauge sending unit.
20. Refit clutch cable with nut and linkage; re-hook wire to eye under engine. Adjust clutch pedal clearance — see Chapter 4.
21. Refit muffler by reconnecting to exhaust manifold and muffler bracket. Note: Do not finally tighten bracket nut until after tightening manifold connection.
22. Reconnect cooling water outlet hose.
23. Refit induction muffler with cleaner and pre-heater.
24. Refix toeboard and replace rubber mats.
25. Refit hood, hood stopper and cables.
26. Reconnect battery ground cable.
27. Refill cooling system and check transmission oil.
28. Test car.

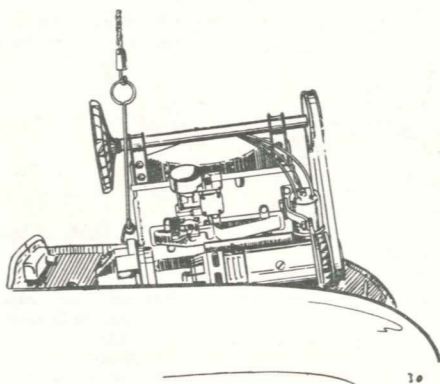

Removal or installation of power unit



## DISASSEMBLY AND REASSEMBLY OF 3-SPEED TRANSMISSION

### DISASSEMBLY

Proceed as follows stage by stage until the part concerned has been removed.

1. Clean gear box unit externally and drain the oil.
2. Remove inner universal joints with shafts. They are connected to differential side gears by bolts through shaft centers.
3. Separate transmission unit at joint between clutch housing and gear box casing. After removal of all bolts it will be necessary to turn clutch shaft to a specific position before casings can be separated. Turn clutch shaft and locate this position at the same time as housing is removed.
4. Install gear box casing in the fixture. See fig.

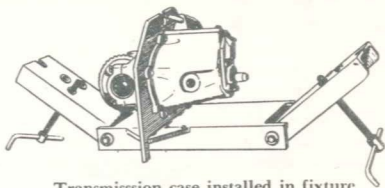

Transmission case installed in fixture

### DIFFERENTIAL, FREEWHEEL, ETC.

5. Release differential bearing caps and lift out differential assy.

#### NOTE

Before further disassembly of transmission always check pinion location and ring gear lash to determine whether these have been incorrect.

#### NOTE

Take good care of spacer rings and shims outside both bearings and note their location, see fig.

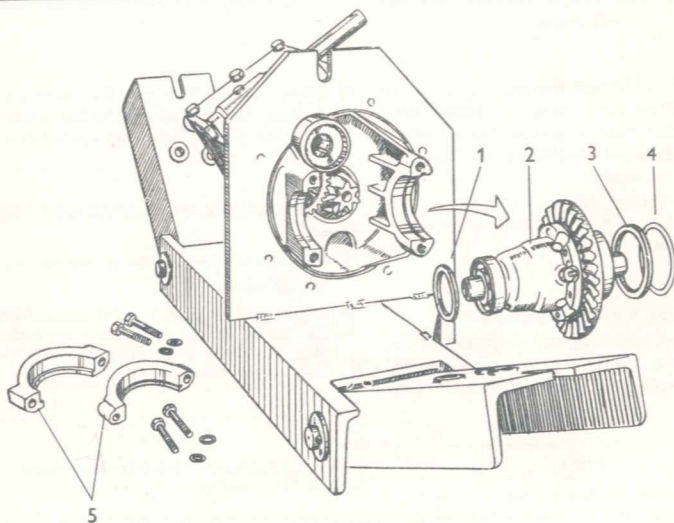

**Disassembly of differential**  
1, 3 and 4. Spacer rings and shims  
2. Differential case  
5. Caps

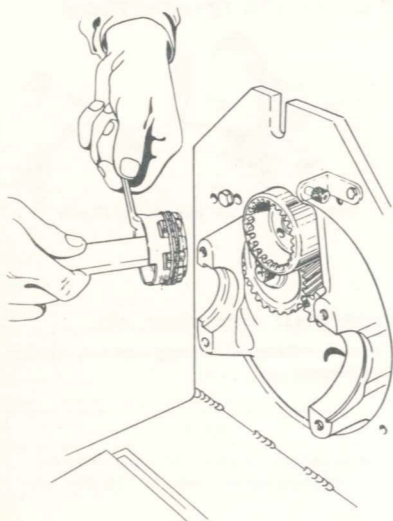

Disassembly or reassembly of freewheel hub with tool 784068

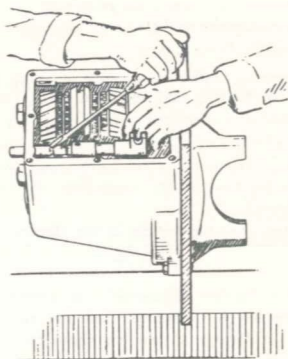

Disassembly of 1st and reverse shift fork

6. Remove freewheel hub together with six rollers from freewheel sleeve, using tool 784068 and a strong rubber band to prevent ejection of rollers. See fig. Remove needle bearing. Check that no rollers are missing.
7. If pinion shaft or bearings are to be removed, measure location of pinion shaft before removing end cover.

#### SHIFT FORKS

8. Remove gear box casing cover.
9. Remove end cover together with attached 2nd and 3rd shift fork rail. Take care that poppet ball is not ejected by spring. Collect shims and washer.

#### NOTE

If only rear pinion shaft bearing is to be removed this may be done now, by backing off nut and extracting bearing with tool 784101.

10. Using a screwdriver, push 1st and reverse shift fork rail through end of gear box casing. Take care that poppet ball is not ejected. See fig.

#### COUNTERSHAFT WITH BEARINGS AND GEARS

11. Shift synchronizer sleeves to engage two gears simultaneously.
12. Loosen nut at front end of countershaft. If also pinion shaft and primary shaft shall be removed, loosen their end nuts. Remove, if necessary, friction wheel and washer.

#### NOTE

Nut on pinion shaft is left-hand threaded.

13. Return synchronizer sleeves to neutral position.
14. Lift up fixture front end plate and secure same.



15. Fit arbor 784110, fitted with the shortest point, between front press screw and countershaft, see fig. Press in shaft arbor hard against gear wheel. Change point to next longest and repeat procedure, than once again with the longest point until bearing and countershaft gear are released. Collect gear key. Remove tool and drop fixture end plate.

16. Lift front end of countershaft, grip gears with one hand, draw shaft through rear bearing opening and remove gear wheels. Take care of washer between 1st speed gear and ball bearing, and also two needle bearings inside 1st gear hub.

Next, if necessary:

17. Remove retainer and drive ball bearing off shaft.

18. Use an arbor to drive or carefully tap the remaining bearing towards differential end. Take care of retainer located behind bearing.

#### MAIN SHAFT WITH BEARINGS AND GEARS

19. Locate transmission fixture rear press screw against main shaft and fit arbor 784104 between screw and shaft.

20. Press shaft forwards, until free from bearings.

21. Back off press screw and remove arbor.

22. Remove shaft in forward direction.

23. Grip synchronizer unit and gears and allow washer from between 2nd speed gear and ball bearing to drop into transmission case. Lift out gear and synchronizer as one unit.

24. If dual needle bearings in 3rd speed gear hub did not accompany shaft, remove these.

25. Remove needle bearings from 2nd speed gear hub.

26. Disassemble synchronizer unit.

27. Drive rear main shaft bearing out of case, using front press screw together with tool 784109 and sleeve 784106.

Next, if necessary:

28. Remove locating washer and lock pin from shaft.

29. Remove retainer and drive ball bearing off shaft.

#### PINION SHAFT WITH BEARINGS AND GEARS

##### NOTE

It is possible to remove rear pinion shaft bearing for bearing replacement or shaft adjustment as soon as end cover has been removed, i.e. without removing counter or main shafts.

30. Fit puller 784101 on pinion shaft rear bearing sleeve and pull out sleeve together with bearing.

Use gear box fixture front press screw to hold-up against the drive pinion. Collect spacer and shims from inside of bearing.

31. Remove speedo. gear.

32. Locate fixture rear press screw against pinion shaft and press shaft forwards. As soon as shaft comes free, draw out same and lift gears from the gear box casing.

33. Drive roller bearings off pinion shaft if necessary.

#### REASSEMBLY

After disassembly has proceeded to the desired stage, clean the cover joint face, removing any remains of gaskets or old sealing compound. Inspect and clean all disassembled parts and the case itself in kerosene or similar solvent. Make sure no parts such as poppet balls, needles from damaged bearings, etc., remain in the case. Commence reassembly at the appropriate point in the following description.

##### NOTE

When fitting new gears note that the following are supplied in matched sets:  
3rd speed gear — pinion shaft 3rd gear  
Countershaft gear — main shaft  
Crown wheel — pinion shaft

Quiet operation is ensured only if gears are replaced as sets, and are fitted with matching numbers facing the same way, in cases where alternative fitting is possible.



# 5 TRANSMISSION



## PINION SHAFT WITH BEARINGS AND GEARS

1. After replacement of worn or damaged parts press roller bearing on to pinion shaft with sleeve 784106, and place two Woodruff keys in appropriate grooves. Note that keys are of different sizes — the thinner is intended for 2nd-and-reverse gear wheel.
2. Place 3rd and 2nd gears in the gear box casing together with speedo. drive.

### NOTE

Place speedo. gear with its chamfered side towards differential. Matching number on pinion shaft 3rd gear should face in same direction as number on 3rd speed gear.

3. Pass in pinion shaft from front.
4. Locate 3rd gear relative to key groove. Ensure that speedo. drive pinion is properly engaged, finally locate 2nd-and-reverse gear relative to key groove. This is easiest done by aligning groove in gear according to groove for lockwasher, which is aligned with shaft key groove.
5. Place fixture front press screw against pinion shaft and press carefully, a fraction of an inch only, so that the drive pinion rides on the shaft. Pinion shaft 2nd-and-reverse gear will now rest against rear wall of the gear box casing. Check that it is at right angles to pinion shaft.
6. Back off press screw a few turns, simultaneously supporting gear wheel, then locate alignment arbor 784102 in rear bearing. Ensure that shaft end passes into arbor.
7. Drive in arbor with fixture press screw until flange of arbor is butts against end of the gear box casing. Allow press screw to remain in this position.
8. Using opposite press screw, drive in pinion shaft from front until roller bearing is hard up against 3rd gear.
9. Back off press screws and remove arbor from bearing seat.
10. Place a 9/64-in. (3.6-mm.) spacing washer on shaft end. Use previously-fitted spacer and shims unless some part of pinion shaft assembly has been replaced.
11. If dual ball bearing and bearing sleeve have been separated, reassemble these parts. Marking on bearing face inwards  
A bearing without marking should be located with the ball-insert facing outwards.

12. Drive in bearing and sleeve assembly with press screw and arbor 784102, using press screw at other end of fixture against pinion shaft as a holding-up tool.
13. Place a new lockwasher on pinion shaft and thread on nut (N.B. left-hand threaded). Torque the nuts after reassembly of main and countershaft. Tab on lockwasher should be turned outwards.
14. Fit speedo. drive.

## MAIN SHAFT WITH BEARINGS AND GEARS

15. Drive ball bearing on to main shaft and fit retainer. Use tool 784107.
16. Insert lockpin in shaft and fit locating washer behind ball bearing retainer. Lockpin should fall into groove in washer to prevent it from rotating.
17. Assemble 3rd speed gear with hub dual needle bearing, synchronizer unit with rings and 2nd speed gear without bearings. Place this assembly in the gear box casing and fit aligning arbor 784114 in the gear boxes end, so that it is entered into 2nd speed gear hub.
18. Pass main shaft into case from front, twisting it gently back and forth so that splines enter synchronizer hub.
19. Pass arbor 784104 into freewheel sleeve.

### NOTE

Needle bearing in freewheel sleeve must be removed, as otherwise it will be damaged.

20. Lift up and secure both fixture end plates and support arbor 784114 with rear press screw.
21. Drive main shaft inwards from the front by means of press screw against arbor in freewheel sleeve, exercising great care. Check that synchronizer hub slides freely on shaft.
22. Back off rear press screw and remove arbor from 2nd speed gear.
23. Fit needle bearings and steel bushing in 2nd speed gear and fit washer on shaft, noting that chamfered side of washer hole should face outwards.
24. Drive in main shaft rear bearing with aid of press screw and tool 784109. Press screw at other end, and arbor 784104 in freewheel sleeve, serve to hold up shaft during this operation.
25. Back off both press screws and remove arbors.
26. Fit a new lockwasher, with tab turned outwards, and nut of shaft end. Do not tighten nut with torque wrench until after refitting countershaft.





### COUNTERSHAFT WITH BEARINGS AND GEARS

27. If countershaft front ball bearing has been removed, drive it from differential side into its place in the gear box casing, until hard up against retainer. For this purpose raise and secure fixture rear end plate and drive in bearing with press screw and driver 784108.
28. Locate countershaft gear on outside of bearing and hold it there with tool 784108, tightening front screw as much as is necessary. Check that countershaft gear matching number is on same side as main shaft pinion number.
29. Assemble reverse gear, and 1st speed gear with its two hub needle bearings and washer. Place this assembly in the gear box casing, simultaneously passing countershaft through rear bearing hole. If ball bearing has not been disassembled it may be left on shaft during reassembly, providing retainer is removed.
30. Drive in shaft, using fixture rear press screw and tool 784104. Check that shaft passes into countershaft gear. If shaft is fitted complete with ball bearing, use tool 784109 instead of 784104. Also use tool 784109 for fitting ball bearing, if this is fitted after reassembly of shaft. Remember to fit ball bearing retainer.
31. Shift synchronizer units to engage two gears simultaneously, then turn 3rd speed gear to bring key grooves in countershaft and countershaft gear in alignment. Drive in key with an arbor.
32. Fit a new lockwasher with tab facing *inwards*, or fit friction wheel with a new friction washer and star washer. Torque countershaft end nut to 58 ft.-lb. (8 kpm). Torque main shaft nut to 36 ft.-lb. (5 kpm). Torque pinion shaft nut, first to 86 ft.-lb. (12 kpm), then loosen and retighten to 43 ft.-lb. (6 kpm).

**NOTE!**

Later gear boxes are equipped with friction wheel for the countershaft. In that case the countershaft wheel is of a different type.

33. Return synchronizer sleeves to neutral position.
34. Turn down lockwasher tabs on countershaft and main shaft end nuts. The pinion shaft nut may also be secured, provided you know for certain, that the pinion is correctly adjusted; if not, leave the nut unlocked until adjustment has been made.
35. Check and, if necessary, adjust shims for end cover,

### SHIFT FORKS

36. Refit spring and poppet ball in 1st and reverse shift fork. Locate shift fork in case and push in shift fork rail. To simplify this operation use tool 784069 to keep poppet ball in place.
37. Refit spring and poppet ball in 2nd and 3rd shift fork and locate shift fork in case.
38. Check that rubber washer and plastic plug are fitted to end cover and that oil collector in case end is fitted.
39. Fit 2nd and 3rd shift fork rail to end cover. Previously used or newly selected shims must be fitted in position, after coating with a little grease so that they adhere to end cover. Also, if no further adjustment of drive pinion is required, coat gasket on both sides with sealing paste, such as Permatex No. 3. Fit end cover, passing shift fork rail into its place. Torque end cover bolts with 18 ft.-lb. (2.5 kpm).
40. If found necessary, back off locknut and adjust 2nd and 3rd shift fork assembly so that fork is not subject to axial pressure when 2nd or 3rd gear is engaged. A definite free clearance should exist between synchronizer sleeve and either gear.

### DIFFERENTIAL, FREEWHEEL, ETC.

41. Check and, if necessary, adjust drive pinion setting.

**NOTE**

Pinion shaft end nut and all bolts in end cover must be tightened with correct torque before measuring drive pinion settings.

42. After correct adjustment of drive pinion do not omit to check that pinion shaft nut is secured, prior to final tightening of end cover bolts.
43. Locate differential and ring gear in differential bearings and check for correct ring gear lash.
44. Fit freewheel hub and rollers into freewheel sleeve, using tool 781068.

**NOTE**

Hub should engage firmly when twisted to right. It is marked on front face.



45. Check that no gears are engaged. Fit the gear box casing cover, coating sealing surfaces with sealing paste, such as Permatex No. 3.
46. Remove gear box from fixture.
47. Clean clutch housing joint surface and apply sealing paste.
48. Insert needle bearing in freewheel sleeve.

#### NOTE!

Inspect the clutch shaft seal, and replace if necessary. The seal to be fitted with the dust guard lip outwards. The space between the sealing lips shall be filled with chassis grease.

49. Refit clutch housing to gear box casing. Turn clutch shaft so that it clears differential. Tap in locating pin.
50. Refit inner universal joints with drive shafts. Be careful not to damage sealing rings or dislocate their springs when passing in shafts.
51. Smear clutch shaft splines with graphite grease and fill gear box unit with about 4 pints (2 liters) transmission oil.

#### DISASSEMBLY

Proceed as follows stage by stage until the part concerned has been removed.

1. Clean transmission unit externally and drain the oil.
2. Separate transmission unit at joint between clutch housing and gear box casing. After removal of all bolts it will be necessary to turn clutch shaft to a specific position before casings can be separated. Turn shaft and locate this position at the same time as differential housing is removed.
3. Install gear box in fixture 784100.

#### NOTE

Before further disassembly of transmission always check pinion location and ring gear lash to determine whether these have been incorrect

#### DIFFERENTIAL, FREEWHEEL, ETC.

4. Release differential bearing caps and lift out differential assy.

#### NOTE

Take good care of spacer rings and shims outside both bearings and note their location, before attempting disassembly of the differential.

5. Remove freewheel hub together with six rollers from freewheel sleeve, using tool 784068 and a strong rubber band to prevent ejection of rollers.
6. Remove needle bearing. Check that no needles are missing. If pinion shaft or bearings are to be removed, measure location of pinion shaft before removing end cover. See Section 11.

#### SHIFT FORKS

7. Remove end cover bolts and drive out 1st—2nd, and 3rd—4th shift fork rails from front side, using arbor or similar tool.
8. As soon as cover is free, remove it to rear, keeping shift forks in position on rails and preventing tipping. Note location of shims inside cover. Collect shims. Take care that poppet balls are not ejected from shift fork assemblies.
9. If only rear pinion shaft bearing is to be removed this may be done now by engaging two gears (reverse and 3rd), releasing lockwasher and backing off end nut (left-hand threaded). Bearing may then be removed with puller 784115, replacement or, if required, for shimming of pinion shaft.
10. Using a screwdriver, release reverse shift fork rail and draw it out rearwards. Take care that poppet ball is not ejected.
11. Lift shift forks out of the gear box casing.

#### COUNTERSHAFT WITH BEARINGS AND GEARS

12. Engage two gears simultaneously, e.g. reverse and 3rd.
13. Open lockwasher, and loosen nut at front end of countershaft. Remove friction wheel and friction washer. If also pinion shaft and/or main shaft shall be removed, loosen their end nuts.

#### NOTE

Nut on pinion shaft is left-hand threaded.



14. Return synchronizer sleeves to neutral position. Lift up fixture front end plate and secure same.
15. Fit arbor 784110, fitted with the shortest point, between front press screw and countershaft, see fig. Press in shaft until arbor is hard against gear wheel. Holding-up tool 784125 should now be placed between 1st speed wheel and case rear end, Change point to next longest and repeat procedure, then once again with the longest point until bearing and countershaft gear are released. Collect gear key. Remove tool and drop fixture end plate.
16. If bearing is still in position, tap free with help of an arbor.
17. Grip rear end of shaft and draw it out rearwards, causing countershaft gear to be freed. Locating washer at front bearing will drop down into case; ignore this but grip 1st and 2nd speed gears together with synchronizer unit and lift whole assembly out of the gear box casing. Collect the washer.

Next, if necessary:

- a) Remove retainer and drive rear ball bearing and bearing seat from shaft, after which reverse gear can be removed.
- b) Main shaft must be disassembled if countershaft front bearing or countershaft gear are to be replaced.

#### MAIN SHAFT WITH BEARINGS AND GEARS

18. Remove main shaft end nut and lockwasher; lift up and secure fixture rear plate.
19. Locate gear box fixture rear press screw against main shaft and fit arbor 784104 between screw and shaft. Press shaft forwards, see fig., until free from bearings.
20. Remove shaft in forward direction. Grip synchronizer unit and gears and allow washer from between 3rd speed gear and ball bearing to drop into gear box casing. Lift out gears and synchronizer as one unit.
21. Removal of main shaft also releases countershaft gear. Countershaft front bearing can also be removed by gently tapping with a fiber mallet towards differential side.
22. Drive rear main shaft bearing out of case, using front press screw together with tool 784109 and sleeve 784106.

Next, if necessary:

- a) Remove locating washer and lockpin from shaft.
- b) Remove retainer and drive ball bearing off shaft.

#### PINION SHAFT WITH BEARINGS AND GEARS

##### NOTE

It is possible to remove rear pinion shaft bearing for bearing replacement or shaft adjustment as soon as end cover has been removed, i.e. without removing counter or main shafts.

23. Remove speedo. drive.
24. Remove pinion shaft end nut (left-hand threaded) and fit puller 784115 on pinion shaft rear bearing out bearing, using front press screw to hold up pinion shaft. Collect spacer and shims from inside of bearing.
25. Locate holding-up tool 784121 on underside of shaft between rear gear wheel and front end of case, see fig. Check that tool is centered on gear wheel so that latter does not tend to tilt on shaft.
26. Lift and secure fixture rear plate and drive pinion shaft forward with press screw until roller bearing comes clear of front end of case. Back off press screw and drop rear plate. Draw out shaft and lift 3rd-and-reverse gear out of case simultaneously. Collect Woodruff key, if loose.

Next, if necessary:

27. Drive front roller bearing and pinion shaft 4th gear from shaft, as follows:
  - a) Remove retainer from roller bearing, unless bearing is to be replaced and damage is thus immaterial.
  - b) Place pinion shaft and holding-up tool 784123 in an arbor press and drive out shaft. Note that bearing outer race lies flush against gear wheel. On no account should bearing be disassembled if it is to be used again. Be careful not to lose any rollers when removing and refit retainer at once, expanding it first, so that it presses out correctly in its groove.
28. Press gently on oil collector in the gear box casing, and remove same.





## REASSEMBLY

After disassembly has proceeded to the desired stage, clean the cover joint face, removing any remains of gaskets or old sealing compound. Inspect and clean all disassembled parts and the case itself in kerosene or similar solvent. Make sure no parts such as poppet balls, needles from damaged bearings, etc., remain in the case. Commence reassembly at the point in the following description.

### PINION SHAFT WITH BEARINGS AND GEARS

1. Place front roller bearing, pinion shaft 4th gear, spacer rings and speedo. pinion on pinion shaft. Using an arbor press, drive roller bearing and 4th gear with tool 784106 until bearing inner race is flush against drive pinion. Check that matching number faces same way as that on 4th speed gear.
2. Next pass pinion shaft into the end of the gear box casing, from differential side, and hold pinion shaft 3rd-and-reverse gear in case so that shaft passes through its hub. Check that Woodruff key for 3rd-and-reverse gear has been fitted to pinion shaft. In certain transmission units of older pattern 4th gear is also located by a Woodruff key, instead of being press-fitted.
3. Turn shaft to align Woodruff key with groove in 3rd-and-reverse gear hub.
4. Locate arbor 784122 in rear bearing hole to guide pinion shaft correctly.
5. Secure arbor with the rear press screw. Arbor flange should lie flush against the end of the gear box casing end.
6. Using front press screw, drive pinion shaft finally home, checking that key engages correctly in 3rd-and-reverse gear wheel.
7. Release rear press screw and remove aligning arbor from bearing position.
8. Place a .14-in. (3.6-mm.) spacer on shaft end.

#### NOTE

Use previously-fitted spacer and shims unless some part of pinion shaft assembly has been replaced.

9. Fit retainer to rear bearing and, using press screw and arbor 784122, drive in rear bearing. Use press screw at other end of fixture against pinion shaft as holding-up tool.
10. Release rear press screw, remove tool and drop both fixture end plates.

11. Place a new lockwasher on pinion shaft and thread on nut (N.B. Lh. threaded). Torque the nut after reassembly of main and countershafts, see under 28. Tab on lockwasher should be turned outwards.

### PRIMARY SHAFT WITH BEARINGS AND GEARS

12. Fit front bearing on main shaft with tool 784107, and place retainer, lockpin, spacer washer and 4th speed gear needle bearing on shaft. Check that lockpin actually prevents spacer washer from rotating.
13. Before fitting main shaft it is necessary to place countershaft front bearing and gear in their appropriate positions. Press in bearing from front with aid of arbor 784108 until it is hard up against retainer in bearing seat. Position countershaft gear with matching number facing same way as that on main shaft pinion.
14. Assemble 3rd and 4th speed gears together with synchronizer unit and lift this assembly into the gear box casing, simultaneously passing aligning arbor 784114 through rear bearing opening and into 3rd speed gear hub.
15. Pass main shaft into case from front, twisting it gently back and forth so that splines enter synchronizer hub.
16. Pass arbor 784104 into freewheel sleeve,

#### NOTE

Needle bearing in freewheel sleeve must be removed, as otherwise it will be damaged.

17. Raise up and secure fixture front end plate. Drive main shaft carefully inwards by means of press screw against arbor in freewheel hub, see fig., until 3rd speed gear is hard up against rear case end. Check that synchronizer hub slides freely on shaft.
18. Remove arbor from 3rd speed gear and locate needle bearing, spacer sleeve and bushing on shaft, inside gear hub.
19. Fit spacer washer on shaft, noting that chamfered face should be outwards. Drive in main shaft rear bearing with aid of press screw and tool 784109. Press screw at other end, and arbor 784104 in freewheel sleeve, serve to hold up shaft during this operation.
20. Back off both press screws and remove arbors.
21. Fit a new lockwasher, with tab turned outwards, and nut on shaft end. Do not torque nut until after refitting countershaft.

**COUNTERSHAFT WITH BEARINGS AND GEARS**

22. Assemble 1st and 2nd speed gears, the latter complete with needle bearings, spacer and bushing, together with synchronizer unit.
23. Lift this assembly into gear box casing simultaneously passing countershaft (fitted with needle bearing for 1st speed gear) through transmission case rear end.

**NOTE**

If rear ball bearing, bearing holder and reverse gear have not been disassembled they may remain on shaft during refitting. First, however, bearing must be pressed into holder to permit removal of rear retainer from shaft.

24. Locate spacer washer on shaft between 2nd speed gear and front ball bearing, and pass shaft through front bearing into countershaft gear hub. Hold up gear wheel with front press screw and tool 784108.
25. Erect and secure fixture end plates, and see to it that front press screw and tool 784108 hold countershaft gear and bearing in position, see figures, then drive in the shaft for good. Drop both end plates of fixture, and after pressing in rear bearing secure same with retainer.
26. Press in countershaft with press screw and tool 784109, see fig. Check that the shaft splines engage correctly with synchronizer hub, and the shaft with the countershaft gear. Use hook spanner 784124 to turn shaft,

**NOTE!**

If the countershaft is pressed in, with the reverse gear and bearing on use tool 784109, which shall be used for the pressing in also if the reverse gear and the holder with bearing are fitted separately.

27. Engage two gears simultaneously, e. g. reverse and 3rd, and then turn 3rd speed gear to bring key grooves in countershaft and countershaft gear in alignment. Drive in key with an arbor.
28. Fit a new lockwasher — tab inwards — or fit friction wheel together with, if necessary, a new friction washer and star washer. Torque countershaft end nut to 58 ft.-lb. (8 kpm). If they have been loosened, torque also the nuts of main shaft and pinion shaft, the latter nut is *left-handed*. First the pinion shaft nut should be torqued to 86 ft.-lb. (12 kpm); then loosened and retightened to 43 ft.-lb. (6 kpm). The torque setting for the main shaft nut is 36 ft.-lb. (5 kpm).

**NOTE!**

Later gear boxes are equipped with friction wheel for the countershaft. In that case the countershaft gear is of a different design.

29. Secure all the nuts by folding the lockwasher tabs. If not certain, whether the pinion has been correctly adjusted, leave the pinion shaft nut unlocked until final adjustment has been carried out.

**SHIFT FORKS**

30. Return synchronizer sleeve and reverse gear to neutral position and locate shift forks in case. Note that springs and poppet balls — especially in reverse gear fork — must be fitted and secured with tool 784069 before placing shift forks in transmission case.
31. Pass reverse shift fork rail through case rear end and collect tool holding poppet ball in place, as tool is displaced at fork front end. See fig.
32. Check that rubber washer and plastic plug are fitted to end cover and that oil collector in case end is fitted.
33. After checking of former (or selection of new) shims for end cover, see Section 6, and when end cover is to be finally fitted, affix a new gasket, coated on both sides with Permatex No. 3, to cover.
34. Pass 1st—2nd and 3rd—4th shift fork rails through rear end simultaneously holding shift forks so that they become correctly located on rails.
35. Fit poppet balls in forks; this is simplified if two tools 784069 are employed to locate balls while cover is being pressed in position. Do not omit to fit previously checked or newly selected shims to cover. If shims are coated with a little grease they will adhere satisfactorily to cover.
36. Collect two tools 784069 when displaced from shift forks. Torque end cover bolts with wrench set to 18 ft.-lb. (2.5 kpm).
37. If necessary adjust shift fork assemblies so that no fork is subject to axial pressure during engagement of gear. Approximately the same play should exist between synchronizer sleeves and corresponding gears in all gear positions.
38. **N.B.** Measuring for possible adjustment of pinion shaft should be carried out at this stage.





## DIFFERENTIAL

39. Refit differential assembly and spacer washers. Tighten bearing cap bolts with a torque setting of 25—32 ft.-lb. (3.5—4.5 kgm.).

### NOTE

If pinion shaft adjustment has been changed or any parts in differential assy. have been replaced, drive-pinion clearance must be checked and adjusted as necessary.

40. Fit speedodrive.
41. Coat top cover with sealing compound, such as Permatex No. 3, check that three shift forks in the gear box casing, also shifter and catch in cover, are at neutral; and fit cover on case.
42. Test gear shift mechanism.
43. Fit freewheel hub together with undamaged needle bearing into freewheel sleeve, using tool 784068. Hub should engage when twisted to right.

### NOTE

Inspect transmission shaft seal and replace if necessary.

44. Coat clutch housing joint surface with sealing paste, e.g. Permatex No. 3, and refit housing to transmission case. Turn clutch shaft so that it clears differential. Make sure that clutch shaft is aligned true and that freewheel hub engages correctly with clutch shaft splines.
45. Inspect sealing rings in clutch housing and fit drive shafts, avoiding damage to sealing rings or dislocation of contracting springs.
46. Smear clutch shaft splines with graphite grease and fill transmission unit with about 4 pints (2 liters) transmission oil.

## TRANSMISSION CASE, CLUTCH HOUSING

The transmission unit comprises two main parts, the transmission case proper and the clutch housing. Location of the two parts relative to each other is by a guide stud. There is no gasket between the parts but the joint face is coated with sealing compound, such as Permatex No. 3.

## END COVER

The end cover of the transmission case is bolted in place and provided with a sealing gasket. Both sides of the gasket should be coated with sealing composition:

An oil collector fitted in the transmission case passes oil via a passage, from which it is passed by a rubber washer and a plastic plug to the primary shaft. Check always that the washer presses the plastic plug against the shaft end and that oil passage is not choked.

Shims placed inside the end cover locate the three rear bearing outer races. There are certain differences between the shims for the 3-speed transmission and those for the 4-speed case. See table.

### IMPORTANT

A few 3-speed units for the earliest Saab 96 vehicles have end covers identical to those fitted in the Saab 93, i.e. a distinctive pattern employing a thick gasket and no shims. Do not attempt to use shims with this type of cover — use only the thick gasket.

A new combination of shims will be required, if the end cover or any of the three bearings in the gear box rear end are replaced. If this is ignored, the bearings concerned will not be held in place — or leakage may occur at the gasket after the end cover has been tightened. Shims for the three shafts are available in sizes 0.1 0.15 and 0.30 mm (0.004 0.006 and 0.012 in. resp.). Spare parts No. etc. are found in the table overleaf.

## SHIMMING

1. Remove gear shift fork rails from end cover.
2. Remove end cover gasket and clean both joint surfaces.
3. Check that all bearings are properly fitted.
4. Place a suitable shim combination for one of shafts in end cover. Application of a little grease will keep shims in place.
5. Press end cover in place by hand and measure gap between cover and end of case with a feeler gauge.
6. Adjust shim combination as necessary to secure a gap of 0.01 in.±0.002 in. (0.25 mm.±0.05 mm.). Eliminate risk of error due to misalignment by measuring at several points.
7. Remove shims for first shaft and repeat procedure for other two shafts, one at a time.
8. Refit shift fork rails.
9. Fit a new gasket of thin pattern. Unless adjustment of pinion is to be carried out, coat both sides of gasket with sealing paste. Fit selected shim combinations and refit end cover.
10. Torque bolts with 18 ft.-lb. (2.5 kpm).



## CLUTCH SHAFT

The clutch shaft bearing in the clutch housing locates the shaft only axially. A shaft seal is fitted outside of the bearing.

### REPLACEMENT OF SEALING RING

1. Lift engine from vehicle.
2. Remove clutch release bearing.
3. Pry sealing ring from clutch housing with a screwdriver or other suitable tool, see fig.
4. Take a new sealing ring, and fill the space between the sealing lips with chassis grease, then fit the ring. Make sure that the sealing ring is facing correctly. See figure.
5. Refit release bearing and re-install engine in vehicle.

### REPLACEMENT OF CLUTCH SHAFT OR BEARING

#### DISASSEMBLY

1. Lift transmission case from car, remove inner universal joints, separate transmission case and clutch housing, remove release bearing and clutch shaft sealing ring, see above.
2. Remove retainer from bearing housing inside of sealing ring, also retainer ring comprising rear stop, for freewheel operating sleeve.

#### NOTE

The bearing is primarily intended to locate shaft axially and has considerable radial clearance in housing.

3. Draw out clutch shaft forwards, collecting operating sleeve and freewheel operating fork, which are released hereby.
4. Remove retainers from shaft and drive off bearing.

#### NOTE!

There are sealing rings for two different shaft diameters: one 30 mm (1.18 in.) for previous gear boxes, and another of 25 mm (1 in.) for later gear boxes.

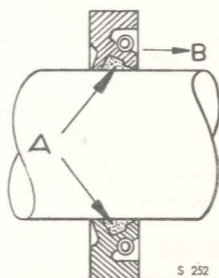

#### Clutch shaft sealing

- A. Fill the space between sealing lips with chassis grease.
- B. Turn this side to face the gear box.

#### REASSEMBLY

1. Fit rear retainer in clutch-housing bearing seat.
2. Drive on bearing on clutch shaft, and fit the retainer. **NOTE!** In later gear boxes the bearing is kept in place by two retainers. See fig.
3. Locate freewheel operating sleeve and fork in clutch housing.
4. Insert clutch shaft from front so that it passes into sleeve, after which rear retainer may be fitted on shaft behind the sleeve.
5. Fit front retainer in clutch-housing and check operation of freewheel lock mechanism.
6. Fit new sealing ring and the old release bearing. Before fitting, fill the space between sealing lips with chassis grease. Fit clutch-housing to gear case, then fit the universal joints.



Clutch shaft, with bearing and freewheel lock mechanism.



Clutch shaft, later design.



## LOCK MECHANISM

### DISASSEMBLY AND REASSEMBLY

1. Lift transmission case from car, remove inner universal joints and separate transmission case and clutch housing.
2. Remove clutch shaft permitting  
removal of operating sleeve and fork.
3. Back off operating lever lock screw, giving access to spring, lever, and poppet ball. Reas-  
semble in reverse order after replacement of worn or damaged parts.

## FREEWHEEL HUB

When the freewheel is overhauled it is usually sufficient to replace the hub and its six rollers. If, however, the freewheel sleeve is defective then the primary shaft must also be replaced —

### DISASSEMBLY AND REASSEMBLY

1. Lift transmission unit from car, remove inner universal joints and separate gear box casing and clutch housing.
2. Remove needle bearing from inside freewheel sleeve.
3. Insert prongs of tool 784068 between freewheel hub and sleeve, then insert other part of tool in hub splines. Twist hub so that rollers are tensioned firmly against tool springs and extract hub until rollers are halfway clear of freewheel sleeve. Fix a strong rubber band round rollers, and extract hub fully — If tool 784068 is not  
available any tool which grips internal splines of hub may be used, hub being turned anticlockwise at the same time as it is carefully ex-

tracted far enough to fix a rubber band round the rollers.

Under each roller there is a spring-loaded plunger. Always inspect plunger for wear and see that it moves freely in its hole, also check spring tension.

Freewheel hub and needle bearing may then be reassembled, in reverse order. Refit transmission unit.

## 3-SPEED TRANSMISSION

To remove and reinstall the countershaft

The countershaft is carried in two ball bearings housed in the gear box casing, the front bearing being secured in the case by a retainer ring. The 1st speed gear rides on the shaft on needle bearings,

while the reverse gear slides on splines. The  
countershaft gear immediately behind the freewheel sleeve is matched with the main shaft and these can only be replaced as a set. Note when refitting that matching numbers shall face the same way.

### 4-SPEED GEAR BOX

To remove and reinstall the countershaft follow the instructions in Section 5.

The 1st and 2nd speed gears ride on the countershaft on needle bearings while the reverse gear slides on splines. A synchronizer unit for the  
1st and 2nd gears is fitted between them, and is identical to that fitted on the main shaft. Synchronizer units are supplied only as complete assemblies exclusive of rings.

The 1st and 2nd speed gears are matched with their respective counter parts on the main shaft. The countershaft gear is also matched with the main shaft. Note when refitting that matching numbers must face the same way.

## FRICITION BRAKE

### GENERAL

The countershaft gear in later 3- and 4-speed gear boxes is equipped with a friction brake, which serves the purpose of eliminating the backlash, thereby reducing the noise.

The device is a friction wheel with one tooth less than the countershaft gear. In this way the friction wheel will turn round slowly as compared with the countershaft gear during rotation. The springing attachment of the friction wheel creates adequate brake power which neutralizes the backlash towards the main shaft.

### Installation instructions

When installing the friction brake, observe the following.

1. Check that the friction wheel's contact surface is plane at the teeth, and that the distance between the spring tongues and the contact surface is within that prescribed. See fig.
2. When installing, see to it that the countershaft gear is placed in a way that makes the turned out (machined) part of the hub face the friction wheel.
3. Check that the backlash, on the back of the countershaft gear at the main shaft bearing, is not below 0,5 mm (0.02 in.). If it is, a special shim shall be fitted between the countershaft's front bearing and the countershaft gear.
4. When the friction wheel has been installed, and the friction washer with locking tab is being fitted, check that there is a certain springing in the spring tongues.
5. When tightening the countershaft gear's nut, see to it that the spring tongues are not squeezed tight. Torque value to be 61 ft.-lb. (8.5 kpm).





## MAIN SHAFT

### GENERAL

To remove and reinstall the primary shaft follow the instructions in Sections 4 and 5, from which it will be apparent that the countershaft must be removed before the primary shaft is accessible.

The main shaft, carried in ball bearings housed in the transmission case, is machined in one piece with the freewheel sleeve and the pinion driving the countershaft. In the 3-speed gear box the 2nd and 3rd speed gears, and in the 4-speed gear box the 3rd and 4th speed gears, are carried on the primary shaft in needle bearings. These gears are matched with their counterparts on the countershaft and pinion shaft.

The synchronizer unit for the gears is located between them, on splines. The units for the 3- and 4-speed gear boxes differ. Synchronizer units are supplied only as complete assemblies, exclusive of rings.

A drilling through the primary shaft supplies oil to the 3rd and 4th speed gear bearings (2nd and 3rd speed gears in the 3-speed gear box) and to the freewheel. Check always that the passage is not choked. A locating washer is fitted against the front bearing of the main shaft and is secured by a lockpin through the shaft to prevent relative rotation.

### SYNCHRONIZATION 3- AND 4-SPEED GEAR BOX

#### Synchronizing rings

The synchronization can operate satisfactorily only if the synchronizing rings are in proper surface contact with the cones. If the ring wobbles when pressed against the cone, then the ring must be lapped. When lapping, proceed as follows: apply fine granular carborundum on the cone of the gear, then turn the ring to and fro against same.

Once the synchronizing ring fits properly, the parts must be very carefully cleaned of abrasive powder.

When fitting a new synchronizing ring, the distance between same and the clutch tooth must not be below 1 mm (0.04 in.). This includes a margin for wear. The smallest permissible distance is 0.3 mm (approx. 0.012 in.).

#### Synchronization power

At gearshifting the synchronizing ring is pressed against the cone of the gear with a certain power, the magnitude of which is depending upon the tension of the synchronizing springs inside the synchronizing hub. If it may be suspected that the synchronizing power is not the right one, it can be measured with the aid of a spring scale or a set of weights, as follows:

Place the gear on a plane surface with the cone upwards. Then place the synchronizing ring and the synchronization device assy. on top.

The parts shall be sparingly oiled. Then depress the coupling muff a few times, until the synchronizing ring is in the correct position. Then apply a ring or similar on the coupling muff, and on top of it a weight of 9 lb. (4 kilos). The muff shall then not move downwards. If, however, the load is increased with approx. 4½ lb. (2 kilos), the muff shall slide downward. Thus, 29—43 ft.-lb. (4—6 kpm) is the power required for moving the coupling muff over the coupling teeth of the gear, that power may be adjusted by expanding the ring-shaped synchronizing springs.

## PINION SHAFT

To remove the pinion shaft and the differential ring gear follow the instructions in Section 4 for the 3-speed gear box, and in Section 5 for the 4-speed gear box. It will be noted there that the countershaft and main shaft must be removed first. For connection of the crown wheel the differential,

The pinion shaft is carried in one roller bearing and a double ball bearing, constituting the axial bearing. In the 3-speed gear box the shaft carries the 2nd-and-reverse gear wheel, and the 3rd gear wheel, both being key fitted. In the 4-speed gear box the shaft carries the 3rd-and-reverse gear and the 4th gear, the former being key fitted and the

latter press fitted. The speedometer gear is located between the other gears. See figs. The pinion shaft gears form matched sets with their counterparts on the primary shaft. Note when fitting that matching numbers must face the same way.

The ring gear and the pinion shaft also form a matched pair and must be replaced as such. They have been tested for transmission noise and adjustment made to secure quietest possible running, the resultant measurements being etched on the parts. Two ratios between pinion and ring gear are available for the 4-speed gear box, the lower ratio being designed originally for the Saab 95 and the higher for the GT 750.





## DRIVE PINION ADJUSTMENT

### GENERAL

Two figures are etched on the drive pinion face: a matching number, which should correspond with that on the crown wheel; and a measurement, see fig. This measurement indicates the distance from the pinion face to the center of the crown wheel.

### MAKE DANA

On drive pinions of the make DANA the marking of the distance to the crown wheel center is made in a different way: only the deviation — in hundredths of a millimetre — from the basic measure 60,94 mm being stated. The basic measure is always one and same.

Example: if the mark is -3, it means that the measure is 60,94 - 0,03 = 60,91 mm.

If there is no such mark, the measure 60,94 mm is definite. At final adjustment of a drive pinion of the make DANA, it is thus necessary to find out — in the way described above — the distance to the crown wheel centre. Then the correct value for the dial indicator can be calculated in the following way.

### MEASURING

When measuring the setting of the drive pinion, the following must be observed:

1. The pinion shaft end nut to have been torqued, first to 86 ft.-lb. (12 kpm), then loosened and retightened to 15—18 ft.-lb. (2—2,5 kpm).
2. The end cover to have been shimmed, to have gasket and the bolts torqued (15—18 ft.-lb. = 2—2,5 kpm). Shimming of end cover, see Section 6.
3. The differential must be removed to permit application of the gauge, which consists of a jig carrying a dial indicator. A special, exchangeable jig wheel is provided for the 4-speed gear box. For zeroing of the dial indicator an accurately calibrated V-block is available, the measurement being recorded on the block itself.

The drive pinion is inspection-measured as follows:

1. Equip gauge jig with wheel pair suitable for V-block and for the 3-speed gear box. The setting in accord. with 2 shall be made, even if the gear box to be checked is a 4-speed.
2. Locate gauge jig, complete with dial indicator, in V-block and set dial to middle of measuring range. If the latter is 10 mm, it is recommended to set dial to 5 mm, i. e. the large hand shall be at 0 and the little at 5. For all readings use scale giving increased values when point is pressed.

3. Locate gauge assembly in differential bearing housings, with indicator point in contact with ground face of drive pinion. Note reading of dial indicator. If a 4-speed gear box is to be measured, fit special wheel to jig after calibrating as per 1, 2 — this wheel is adapted to right-hand bearing housing of 4-speed gear box differential.

4. Calculate the reading which should be obtained as follows:

Example:

1) Set reading of dial indicator	5.00
2) Calibrated measurement of V-block	+61.05
3) Total of (1) and (2)	66.05
4) Etched figure on drive pinion	-60.90
5) Difference between (3) and (4)	+5.15

5. Result of calculation may now be compared with result as actually read on dial indicator. Maximum permissible deviation is  $\pm 0.002$  in. (0.05 mm.)
6. If the permissible departure is exceeded, a new combination of shims is required.

### IMPORTANT

Always measure distance from pinion to ring gear before disassembling gear box casing, to determine whether adjustment has been incorrect. If pinion and crown wheel have been used only for a short mileage (less than 6,000 miles or 10,000 km.) readjustment may be carried out, but after longer mileages the gears will have worn in to other values and adjustment should be made to agree with readings obtained prior to disassembly.

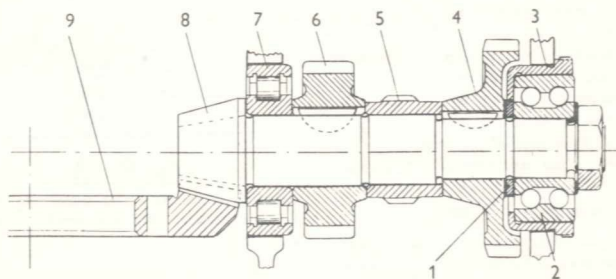

**Adjustment of pinion shaft with shims and spacer (3-speed gear box.)**

- |                     |                         |                   |
|---------------------|-------------------------|-------------------|
| 1. Spacer and shims | 4. 2nd-and-reverse gear | 7. Roller bearing |
| 2. Ball bearing     | 5. Speedo. gear         | 8. Pinion shaft   |
| 3. Bearing sleeve   | 6. 3rd gear             | 9. Crown wheel    |

### ADJUSTMENT

If calculated and actual values differ by more than the permitted tolerance, a readjustment must be made.

Adjustment is made with a spacer and shims which are placed between the rear axial bearing and adjacent gear wheel, see fig. Shims are always to be placed closest to the bearing, the spacer being

located against the gear wheel. Two sizes of spacers and three sizes of shims are available. See table. Make up the package with only one spacer and up to 3 shims in various combinations. This covers a possible adjustment range of from 0.12 to 0.16 in.(3.1-4.2 mm.) with 0.002 in.(0.05 mm. intervals).

Type of gear box	Location	Spacers		Shims	
		Thickness in. (mm)	Part No.	Thickness in. (mm)	Part No.
3- or 4-speed	See fig. above	0.12 (3.1)	782207	0.004 (0.1)	782208
		0.14 (3.6)	782215	0.006 (0.15)	782209
				0.012 (0.3)	782210

Proceed as follows:

1. Remove end cover and back off pinion shaft end nut.
2. Pull out pinion shaft axial bearing with puller 784101 (3-speed transmission) or 784115 (4-speed gear box). Use front press screw as holding-up tool. See figs.
3. Remove spacer and shims.

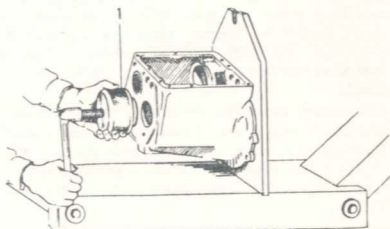

Removal of pinion shaft bearing,

**3-speed gear box**

1. Puller 784101



4. Change shim combination, remembering the following rules:

- increase thickness of package if measured reading was less than calculated.
- reduce thickness of package if measured value was greater than calculated.
- increase of thickness will correspond to difference between actual and calculated readings. Thickness of shim package can be checked by placing measuring gauge in V-block.

5. After selection of correct shim combination place first spacer and then shims on pinion shaft. Drive in axial bearing with tool 784102 (3-speed transmission) or 784122 (4-speed transmission), using front press screw as holding-up tool.

6. Fit lockwasher with tab facing outwards and tighten pinion shaft end nut, first with torque of 85 ft-lb. (12 kpm.) Loosen nut and torque with 35—45 ft-lb. (5—6 kpm.). Secure nut.

7. Fit end cover with its shims. Coat gasket with sealing paste (e.g. Permatex No. 3). Torque cover bolts to 15—18 ft-lb. (2—2.5 kpm.).

## RECHECK

Refit gauge assembly in differential bearing and check that the correct (calculated) reading is now obtained on the dial indicator [within .002 in. (0.05 mm.)] If not, adjustment must be repeated.

## ADJUSTING CROWN WHEEL LASH

During adjustment and measurement of crown wheel lash, the pinion shaft end nut must always be tightened to correct torque, as must the end cover bolts. The end cover must also be properly shimmed.

A matching number is etched on the crown wheel and this should be identical with that on the pinion. The correct backlash value is also etched on the crown wheel. Certain teeth on the matching gears are also marked, as shown, and these should be meshed when the adjustment is measured. Backlash shall not deviate from the indicated value by more than  $\pm 0.002$  in. (0.05 mm.).

The crown wheel backlash may be corrected by means of shims and spacers. For each bearing there are two sizes of spacer and three of shims — see table. Make up the shim package with one spacer and up to three shims in various combinations.

## MEASUREMENTS AND ADJUSTMENT

1. Locate differential and crown wheel assembly in bearings and turn until marked teeth are meshed,

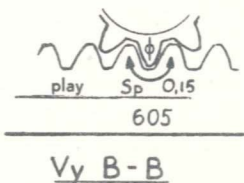

Relative location of crown wheel and drive pinion when assembled for measurement of backlash.

### NOTE

When measuring before disassembly of the gear box, the crown wheel has to be rotated until the marked teeth are in mesh as illustrated in the above figure.

2. At the smaller bearing housing insert a suitable spacer and — between the spacer and the bearing — a suitable shims combination, to secure approximately correct backlash.
3. Fit spacer and shims at other bearing housing, again with shims closest to bearing. Select total thickness sufficient to eliminate differential side clearance, but not to cause tension between the bearings. A reasonable fit is obtained if the spacer is pressed in with thumb pressure.
4. Fit bearing caps and torque bolts with 25—32 ft-lb. (3.5—4.5 kpm.).

### NOTE!

In a 4-speed gear box the R. H. and the L. H. bolts differ in length from each others.

5. Check backlash with a dial indicator mounted in holder on gear box fixture. Equip instrument with a short indicating point and align so that it is at right angles to tooth flank at ring gear periphery.
6. Lock pinion shaft by inserting a screwdriver, for example, through opening for speeddrive. Check that gears are dry and that marked teeth are meshed. Move ring gear gently back and forth, noting reading on dial indicator. Backlash must not vary more than  $\pm 0.002$  in. (0.05 mm.) from etched values. Check backlash at a further four points round ring gear.

**NOTE**

Certain gear sets are not marked as illustrated. Adjust backlash of these sets as follows: Measure to determine maximum and minimum backlash. Take the mean of these and turn ring gear until a backlash measurement equal to the mean is obtained. In this position, adjust the gear to the etched value, as described above.

7. If backlash does not agree with etched value, bearing caps must be removed and a new combination of spacer and shims selected. Note that if shims are removed from one side a similar thickness must be added on the other. A change of .002 in. (0.05 mm.) in shimming corresponds to about the same change of backlash.
8. Recheck adjustment after each change of shim packs.

**IMPORTANT**

Never omit to measure pinion/ring gear adjustment and ring gear backlash before disassembling gear box, in order to check whether these have been incorrect. Readjustment to nominal values is possible if the gear set has been used for not more than 6,000 miles (10,000 km.) but after longer mileages the gears will have worn themselves in and should be adjusted to the actual measured values when the gear box is reassembled.

**REPLACING PINION SHAFT AXIAL BEARING**

To replace the rear axial bearing on the pinion shaft separate the clutch housing from the gear box casing and mount the latter in the fixture.

**DISASSEMBLY**

1. Remove differential and record pinion/crown wheel adjustment.
2. Remove gear box casing cover and end cover.
3. Engage two gears simultaneously and back off pinion shaft end nut (N.B. Left-hand threaded).

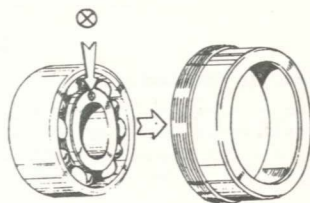

Fitting pinion bearing in sleeve (3-speed transm.)

4. Remove pinion shaft axial bearing with puller tool 784101 (3-speed gear box) or tool 784115 (4-speed gear box). Use the front fixture press screw as holding-up tool.
5. Drive bearing out of its sleeve (in 3-speed gear box only).

**REASSEMBLY**

1. Drive bearing into sleeve — note that letters and marking on bearing shall face inwards (see fig.). Should there be no marking on the bearing the ball insert shall face outwards.
2. Check that shims and spacer are fitted, and drive bearing assy. into gear box casing with tool 784102 (3-speed gear box) or 784122 (4-speed gear box). Use the front press screw as holding-up tool.
3. Torque pinion shaft end nut with 85 ft-lb. 12 kgm.) first, then loosen and torque with 35—45 ft-lb. (5—6 kpm.).
4. The new bearing will have altered adjustment of pinion and also pinion shaft adjustment relative to end cover. End cover shimming must first be adjusted.
5. Fit end cover and torque bolts with 15—18 ft-lb. (2—2.5 kpm.).
6. Check and adjust distance between pinion and crown wheel, as above.
7. After final adjustment secure pinion shaft end nut, refit cover and torque bolts.
8. Reassemble differential and gear box casing, with associated shims. Remove gear box casing from fixture and join clutch housing.





## DIFFERENTIAL

### 3-AND 4-SPEED TRANSMISSIONS

There are two patterns of differential: with split case and with integral case. See figs. Two patterns of ring gear are also supplied, since the fitting of this part is different in the two differential types.

#### DISASSEMBLY

It is not necessary to mount the transmission case in the fixture to disassemble the differential, but doing so simplifies checking and adjustment of the ring gear backlash.

#### NOTE

To replace parts in the differential assembly with integral case, only the two long ring gear bolts locating the differential pinion shaft need be unscrewed. This shaft and the pinions may then be removed without disassembling any other parts.

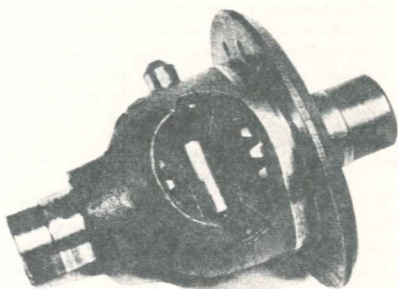

Differential with integral case

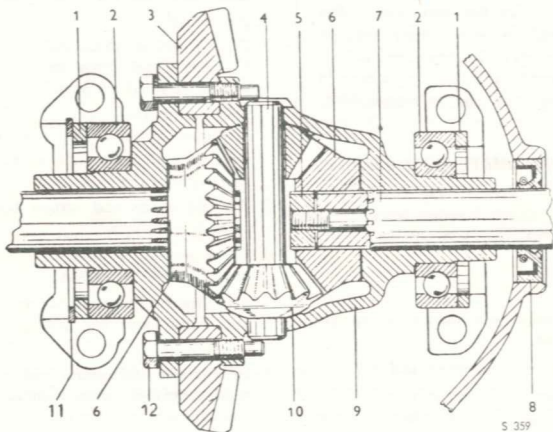

Cross-section of divided differential

- |                              |                 |                         |
|------------------------------|-----------------|-------------------------|
| 1. Spacer and shims          | 5. Splined nut  | 9. Differential case    |
| 2. Ball bearing              | 6. Side gear    | 10. Differential pinion |
| 3. Crown wheel               | 7. Output shaft | 11. Retainer            |
| 4. Differential pinion shaft | 8. Sealing ring | 12. Retaining bolt      |

S 359



1. Remove inner universal joints and clutch housing.
2. Remove differential bearing caps and lift out differential assy. Collect shims and spacers from outside of bearings.
3. If necessary, drive off both bearings from differential output shafts.
4. Remove ring gear and drive out differential pinion shaft.
5. Remove pinions from differential and collect both splined nuts, which axially locate differential output shafts.

#### REASSEMBLY

##### IMPORTANT

Ring gear and pinion shaft are fitted in matched sets and must always be replaced as such.

1. After replacement of worn or defective parts, fit splined nuts on output shafts (inside side gears). Remember to fit retainers rings.
2. Locate pinions in differential case and drive in pinion shaft.
3. Fit ring gear and torque bolts with 15—18 ft-lb. (2—2.5 kpm.). If differential case is of divided type these bolts also connect case halves, besides locating the differential pinion shaft in an axial sense.
4. Secure ring gear bolts with lockwire or lock-washers, and fit differential side bearings if previously removed.
5. Locate differential in bearing housings and fit shims and spacers outside bearings. Check that no side play exists, but that bearings are not under pressure either. Spacer should be fitted with thumb pressure. If any part affecting the total width of differential assembly has been replaced — e.g. a bearing — ring gear backlash must be rechecked. for measurement and adjustment.
6. Fit bearing caps and torque bolts with 25—32 ft-lb. (3.5—4.5 kpm.). Reassemble clutch housing and inner universal joint.

### GEAR-SHIFT MECHANISM

#### 3-SPEED TRANSMISSION

The gear-shift mechanism comprises the shift forks, shift fork rails, poppet balls and springs (these parts in the transmission case proper) and the catch and shifter assembly in the gear box casing cover,

#### DISASSEMBLY

If the work in hand concerns the gear-shift mechanism only it is sufficient to lift the power unit from the car and remove the gear box casing top cover, and possibly the end cover.

1. Remove gear box casing cover, together with 2nd and 3rd shift fork rail — Collect poppet ball and spring.

##### NOTE

Exercise care throughout. Collect shims inside end cover, noting carefully their positioning at the bearings.

3. Drive 1st and reverse shift fork out through end of gear box casing, using a screwdriver. Collect poppet ball and spring.
4. Lift out shift forks.
5. For replacement of any parts included in top cover — shifter, shifter shaft or catch — it is necessary to drill out the rivet or countersunk head in top cover (necessary to drive out pin from shifter shaft). After reassembly, plug hole in cover with a rubber plug or self-tapping bolt.

#### REASSEMBLY

Before reassembly remove all remains of old gaskets and sealing compound from gear box casing covers and joint surfaces on transmission case.

1. After replacement of worn parts, locate shift forks in gear box casing.
2. Insert 1st and reverse shift fork rail through appropriate forks. Use tool 784069 to retain poppet ball and spring. Catch tool as it is ejected.
3. Fit end cover complete with 2nd and 3rd shift fork rail, using tool 784069 to retain poppet ball and spring. Take care to re-locate bearing shim packs correctly, or select new shim combinations  
Coat cover gasket with sealing composition, e.g. Permatex No. 3.
4. Fit and torque cover bolts with 15—18 ft-lb. (2—2.5 kpm.).
5. Check and, if necessary, adjust 2nd and 3rd fork rail to ensure that synchronizer sleeve has definite play relative to 2nd or 3rd speed gear, respectively, when engaged; and that this play is about equal.
6. Locate shift forks in neutral and fit top cover so that catch and shifter are correctly located. Coat cover joint with sealing compound.
7. Check that vent hole in shifter shaft is not obstructed.
8. Test gear-shift mechanism.



### NOTE

The gear box casing is ventilated through the shifter and the hole located on its underside, below the universal joint. Check that this hole is not choked, and that the cork providing a seal against the joint has not been displaced over the hole. Oil leakage at the seals may occur if the vent hole is obstructed.

### 4-SPEED TRANSMISSION

If the work in hand concerns the gear-shift mechanism only it is sufficient to lift the power unit from the car and remove the gear box casing top cover, and possibly the end cover.

1. Remove gear box casing cover.
2. Back off end cover bolts and remove cover by inserting a thin screwdriver under each side and gently prying it loose.

### NOTE

Exercise care throughout. Collect shims inside end cover, noting carefully their positioning at the bearings.

3. Two shift fork rails will accompany cover when removed, see fig. Collect shift fork poppet balls when these are ejected as rails come clear.
4. Release reverse shift fork rail by means of an arbor or screwdriver, after which shaft may be driven out with a screwdriver or pulled out with pliers. Catch poppet ball from fork to avoid losing it in gear box casing.
5. Lift shift forks out of case.
6. For replacement of any of parts included in top cover — shifter, shifter shaft or catch — it is necessary to drill out the rivet or countersunk head in top cover (necessary to drive out pin from shifter shaft). After reassembly plug hole in cover with a rubber plug or self-tapping bolt.

### REASSEMBLY

Before reassembly remove all remains of old gaskets and sealing compound from gear box casing covers and joint surfaces on gear box casing.

1. Check that no poppet balls have been lost in case (pass a magnet over case bottom, for example).
2. Locate synchronizer sleeves and reverse gear in neutral and place shift forks in gear box casing.

### NOTE

Reverse shift fork should be fitted with spring and poppet ball before placing it in case. Retain ball with tool 784069 —

3. Drive in reverse fork rail, collecting tool 784069 when ejected from fork front end.
4. Coat end cover gasket with Permatex No. 3 or other suitable composition and check that rubber washer and plastic plug are fitted in cover.
5. Locate shim packs as previously, or select new shim combination: Light greasing of shims facilitates their retention in end cover during fitting.
6. Commence fitting of end cover, inserting shift fork rails through gear box casing end and into appropriate forks. Retain poppet balls and springs in forks with two tools 784069, as with reverse shift fork, above. Alternatively, if tool 784069 is not available, press down poppet balls with a small arbor or similar tool. The operation is then simplified if one gear is engaged and one rail passed into its fork slightly in advance of the other.
7. Tighten and torque end cover bolts with 15–18 ft.-lb. (2–2.5 kpm.).

### WARNING

Check that bolt opposite reverse shift fork is not excessively long, thereby preventing fork movement.

8. Check and adjust shift fork rails — so that no fork is subject to axial pressure when a gear is engaged. Visible clearance, as far as possible equal for each gear, should exist between synchronizer sleeve and gear when gears are engaged.
9. Locate all three forks and shifter and catch assembly in top cover at neutral.
10. Coat gear box casing joint surface with sealing compound, e.g. Permatex No. 3, fit cover and tighten bolts.
11. Check that vent hole in shifter shaft is not obstructed.
12. Test gear-shift mechanism.

### NOTE

The gear box casing is ventilated through the shifter shaft and the hole located on its underside, below the universal joint. Check that this hole is not choked, and that the cork providing a seal against the joint has not been displaced over the hole. Oil leakage at the seals may occur if vent hole is obstructed.



## INNER UNIVERSAL JOINT

### GENERAL

Within the universal joint power is actually transmitted by two rubber rings. Excessive compression of the rubber may lead to transmission of engine vibration to the body panels. A wire ring, available in three thicknesses, may be fitted between the halves of the universal joint to reduce the compression of the rubber. Parts Nos. are: 710441, 0.06

in. (= 1.5 mm), 710437, 0.08 in. (= 2 mm), and 710442, 0.1 in. (= 2.5 mm). The size selected will depend on the adjustment required in each case, but the 2.0-mm ring should be tried first. To fit the ring, simply back off the universal joint bolts a little, insert ring and tighten bolts again.

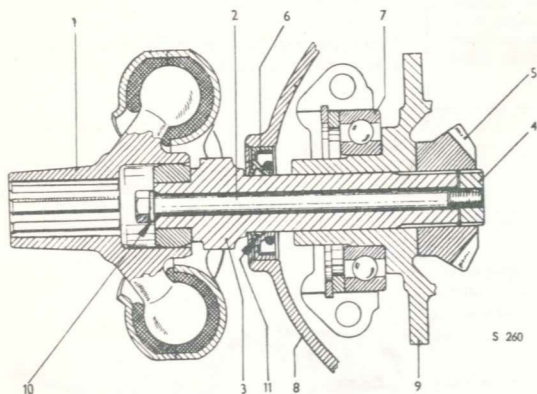

1. Inner universal joint
2. Bolt
3. Output shaft
4. Splined nut
5. Differential side gear
6. Sealing ring
7. Ball bearing
8. Clutch housing
9. Differential case
10. Flat washer, in later design also O-ring
11. Fill the space between sealing lips with chassis grease

Output shaft with inner universal joint

### DISASSEMBLY AND REASSEMBLY

1. Jack up car and remove front wheel.
2. Remove upper suspension arm ball joint from steering knuckle, on same side as universal joint which is to be disassembled.  
This is most easily done by backing off two bolts retaining ball joint and steering arm to steering knuckle. See Chapter 9.
3. Withdraw drive shaft from inner universal joint.
4. Back off bolt retaining inner universal joint and output shaft to differential case — see fig. Collect spring located outside bolt.
5. Remove inner universal joint and shaft — see fig.
6. Open up joint and remove rubber rings. After replacement of defective parts, reassemble in reverse order.

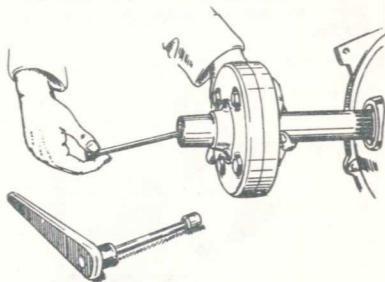

Removal of output shaft and inner universal joint





### NOTE!

There are two different drive shafts, namely the old type with splines of diameter 23.8 mm (0.937 in.), and the new type in the size 24.9 mm (0.982 in.). The corresponding differential gear is also available in two types. When fitting a drive shaft or a differential wheel, it is imperative to check that they match each others without play. This is sometimes hard to determine, the difference between the diameters being only 1 mm (0.04 in.). The risk is that it is possible to fit the thinner shaft together with a differential wheel with large hole. If done, the consequence would be excessive play in the splines, which in turn causes noise and rapid wear.

### REPLACEMENT OF SEALING RING

1. Remove inner universal joint as described on previous page.
2. Prise sealing ring from casing with a screwdriver, for example. See fig. Check that seal contraction ring is still located in the seal. Should the spring be missing, drain the transmission, rinse it and top up with new oil.
3. Insert a new sealing ring with help of tools 784033 and 784030.

### IMPORTANT!

Before fitting the universal joint, the space between the sealing ring lips shall be filled with chassis grease. When fitting the drive shafts, take very great care that the splines do not ruin the sealing.

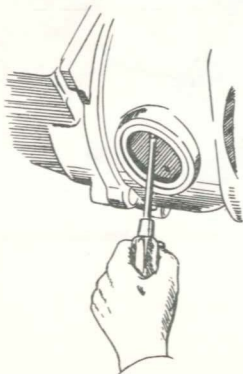

Removal of sealing ring around output shaft

### SPEEDOMETER DRIVE GEAR

#### DISASSEMBLY AND REASSEMBLY

1. Disconnect speedometer drive cable from transmission case.
2. Unscrew and remove bearing sleeve 1 (see fig.) complete with spindle 2 and gear 3. Collect seal 5.
3. Drive out pin 4, which retains gear on spindle; gear, spindle and bearing sleeve can be disassembled.

After replacement of worn or defective parts, reassemble in reverse order.

#### SHIMMING

To prevent oil leakage, the spindle's axial play shall be 0,05—0,2 mm (0.002—0.008 in.). The play may be adjusted with shims 0,2—0,5 mm (0.08—0.02 in.) thick, which shall be placed between gear and sleeve.

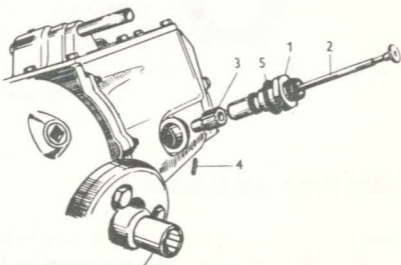

Speedometer drive

- |                   |                  |
|-------------------|------------------|
| 1. Bearing sleeve | 4. Retaining pin |
| 2. Spindle        | 5. Seal ring     |
| 3. Gear           |                  |



## DESCRIPTION

## GENERAL

The fuel system comprises the fuel tank, fuel line, pump and carburetor with air cleaner. Fuel filters are incorporated both at the pump and at the fuel-line banjo connection to the carburetor.

The fuel tank is located under the forward part of the wooden floor in the trunk, immediately behind the rear axle, and is secured by two straps. Made of lead-plated sheet steel, the tank incorporates a wash bulkhead and mixer device. The fuel line is connected to a nipple, located in a plate which is soldered to the tank. The length of the fuel suction pipe inside the tank is arranged to prevent the

induction of small particles of dirt in the tank, these remaining on the bottom. A drain plug, accessible from under the car, is provided. An electric sending unit for the fuel gauge is fitted in the top of the tank.

The fuel line is of Bundy tube (copper-plated steel tube). From the tank it is led along one of the floor pan channels to the front right wheel house, to which the electric fuel pump (which is provided with a filter) is fixed. Fuel passes from the pump to the carburetor through a flexible hose.

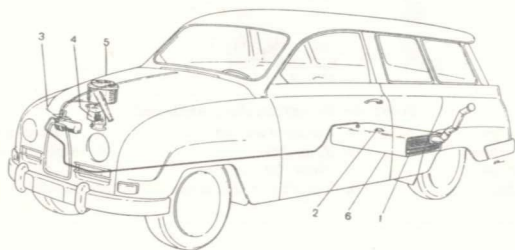

Fuel system, Saab -95



Fuel system Saab 96 and GT 750

1. Fuel tank
2. Fuel gauge tank unit
3. Fuel pump
4. Carburetor
5. Suction silencer with filter element
6. Drain plug (accessible from under the car).



### CARBURETOR

The engine is equipped with a single down-draught carburetor, with a fuel filter in the supply line banjo union. The most frequent carburetor types are SOLEX 40 AI or 40 BI, but also ZENITH 34 VNN is found in certain engine series.

The primary difference between these makes lies in the cold-starting arrangements: the Solex has a separate jet combination, also known as a bi-starter, while the Zenith carburetor has the usual choke, referred to as the strangler flap. For tuning of GT-750 is available a twin, down-draft carburetor, SOLEX 44 PII.

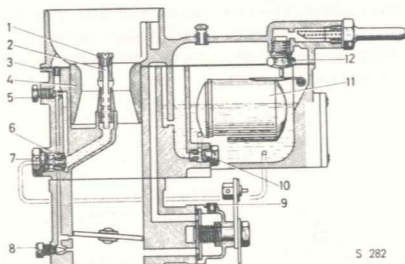

S 282

**Solex 40 BI carburetor, sectioned**

- |                   |                        |                      |
|-------------------|------------------------|----------------------|
| 1. Emulsion jet   | 5. Idling fuel jet     | 9. Starter air jet   |
| 2. Emulsion tube  | 6. Main jet            | 10. Starter fuel jet |
| 3. Idling air jet | 7. Main jet carrier    | 11. Float            |
| 4. Choke tube     | 8. Throttle stop screw | 12. Needle valve     |

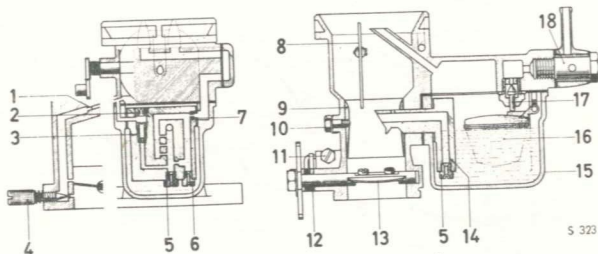

S 323

**Zenith 34 VNN carburetor, sectioned**

- |                         |                              |                    |
|-------------------------|------------------------------|--------------------|
| 1. Idling air passage   | 7. Main air jet              | 13. Throttle flap  |
| 2. Idling air jet       | 8. Strangler flap            | 14. Emulsion block |
| 3. Idling fuel jet      | 9. Choke tube                | 15. Float chamber  |
| 4. Air regulating screw | 10. Screw, fixing choke tube | 16. Float          |
| 5. Main jet             | 11. Throttle stop screw      | 17. Needle valve   |
| 6. Compensating jet     | 12. Throttle lever           | 18. Fuel filter    |



## FUEL TANK AND LINE

### FUEL TANK

#### DISASSEMBLY

1. Drain fuel from tank through drain plug, accessible from under car.
2. Remove rear seat cushion and back (remove same from occasional seat, in station wagon).
3. Saab 95: Remove sheathing over tank by unbending the two spiral fasteners.  
Saab 96: Lift out spare wheel and remove front section of trunk floor.
4. Release tank ground lead from body and disconnect leads to fuel gauge tank unit.
5. Disconnect fuel line from tank.
6. Back off nuts on both tank retaining straps. On the Saab 96, these nuts are accessible through holes in the rear sloping panel.
7. Jack up car and release air filler and tube clamps under rear fender.
8. Raise right side of tank and remove tank in an upwards and rearwards direction.
9. Collect rubber seal from wheel house.

#### REASSEMBLY

1. Refit rubber seal to air and filler tubes. Refitting is simplified if the seal is provided with a leather thong, or similar, in its groove.
2. Check that tank straps are correctly located and cover top of tank filler connection and opening for fuel gauge sending unit with masking tape.
3. Install tank in correct position, passing tank filler connection and seal thong ends out through hole in wheel house.
4. Refit rubber seal to panel by pulling thong ends — as thong is drawn out, check that seal groove enfolds edge of panel opening.
5. Remove masking tape, rejoin air and filler tubes and refit clamps.
6. Refit wheel, and lower car to floor.
7. Reconnect fuel line to tank, then tighten tank straps.
8. Reconnect tank ground cable to body and leads to fuel gauge tank unit.
9. If fuel gauge tank unit has been removed, its gasket must be coated with sealing compound (Permatex No. 3) before refixing.

10. Refit trunk floor or sheathing, as appropriate.
11. Replace seats.

### FUEL LINE

To replace the fuel line it is necessary to lift the power unit from the car. Make joins in the line only if absolutely unavoidable and exercise great care in their execution. Joins may under no circumstances be made inside the passenger compartment.

#### REMOVAL

The power unit must first be lifted from the car.

1. Remove seats and mats from the car.
2. Remove front part of trunk floor and right side of toeboard.
3. Disconnect fuel line from tank and pump, and bend open all clips and floor brackets. Collect all rubber cushions from around line, inside the car.
4. Cut line 6—8 in. (15—20 cm.) behind the floor cross member (supporting rear seat cushion), placing rear section of line in a safe place.
5. Draw rest of line clear, through engine compartment.

#### INSTALLATION

1. Attach fuel line rear nut and cover opening with tape.
2. Blow all dirt and dust, etc., away from floor channel in which the line runs, and adjust brackets and clip as necessary to ensure clear run.
3. From the front, pass new line through hole in cowl plate.
4. Bend rear section of line behind cross member to same shape as removed line.
5. Remove tape from connection nut and connect line to fuel tank and pump.
6. Fit rubber cushions round line, fit rubber seal in cowl plate, and secure line with clips and brackets.
7. Refit toeboard, trunk floor, mats and seats.





### JOINS IN FUEL LINE

Full replacement of the fuel line is a major operation and it may be preferable, therefore, to remedy leaks in the engine compartment by introducing short new sections in the existing line. Joins may be made either by flanging the free ends and arranging a screwed connection or by using a piece of synthetic hose of suitable size. If hose is used, it must be worked at least 4 in. (10 cm.) on to the free ends of the line.

### CLEANING FUEL SYSTEM

Both tank and fuel line must be cleaned if impurities in the tank are suspected. To do this, drain the fuel tank and flush it out with pure gasoline or spirit. See that the tank is kept horizontal, so that sediment does not collect at one corner. A more thorough flushing is secured if the gauge sending unit is removed and the stream of flushing fluid directed from this hole to the various corners of the tank. Disconnect the fuel line from the tank and fuel pump and blow it through with compressed air. Remove and clean the fuel filters at the pump and the carburetor. Remove the carburetor cover, dismantle float and main jet, and clean these parts by means of compressed air. Only in exceptional cases need the tank be removed from the car for cleaning.

## FUEL PUMP

### GENERAL

All Saab cars are equipped with an S. U. electric pump with a built-in filter. The pump is fixed to the right front wheel house.

The S.U. electric fuel pump, as illustrated, comprises three main parts: pump body with valves and fuel filter, the magnet assembly with diaphragm, and the contact breaker. The valves are located under the outlet union on the pump body. The outlet union is tightened down on the delivery valve cage, which is clamped between two fiber washers. The valve consists of a thin brass disc held in position by a spring clip. Inserted in the bottom of the cage is the suction valve, being a similar disc to the delivery valve and held lightly on a seating machined in the body by a spring. Holes connect the space between the valves and the pumping chamber. The filter is screwed into the bottom of the body and may be removed for cleaning by unscrewing the filter plug

The magnet housing containing the magnet iron core and coil is joined to the pump body by six screws. A spacer is interposed and this has a gasket against its face towards the pump body and a diaphragm pressed against its other face by the flange of the magnet housing. A bronze rod to which the diaphragm is attached, is screwed through the contact breaker, located at the other end. The tension of a volute spring interposed between the armature and the end plate of the coil determines pump pressure. Eleven brass rollers fitted between the magnet housing and the armature locate the armature centrally within the magnet without interfering with freedom of movement in a longitudinal direction.

The contact breaker consists of a small bakelite molding carrying two rockers, which are both hinged to the molding at one end and connected at their top ends by two small springs, arranged to secure a throw-over action. A trunnion is fitted to the center of the inner rocker and the bronze push rod referred to above is connected to this. The point of the outer rocker makes contact with another point on a spring blade. One end of the coil winding is connected to this blade, while the other end is connected to a terminal screw adjacent. The rocker assembly is grounded by a lead to one of the fixing screws of the bakelite molding.

When the pump is at rest the outer rocker lies in the outer position and the tungsten points are in contact. As soon as current is switched on, it passes from the terminal through the coil, back to the blade, through the points and to the earth return. The magnet is energised and attracts the armature, which brings the diaphragm with it and thus sucks gasoline through the suction valve into the pumping chamber. When the armature has nearly reached the end of its stroke the throw-over mechanism operates and the outer rocker flips back, breaking the circuit. The volute spring immediately pushes the diaphragm and armature back again and gasoline is forced through the delivery valve. As the armature reaches the other end of its stroke, the throw-over action again occurs, the circuit is closed and the next stroke of the pump is started.

The back pressure existing in the delivery line is determinant for the rate of the pump, this pressure being determined by the float valve in the carburetor.

To determine whether a pump is intended for 6 or 12 volts remove the bakelite cover: if the leads to the coil are green, it is a 6 V pump; if they are red, black or brown, it is a 12 V pump.



### DISASSEMBLY

Carry out a complete disassembly as follows.

#### TROW-OVER MECHANISM, DIAPHRAGM

1. Before disassembling, wash pump in kerosene or similar solvent.
2. Back off six screws joining magnet housing and pump body.
3. After removal of these screws, pump will separate in three parts: magnet housing 5, with contact breaker; pump body 1; and spacer 2 with gasket 18.

4. Unscrew diaphragm assembly 3 from trunnion in contact breaker, until bronze push rod is released.

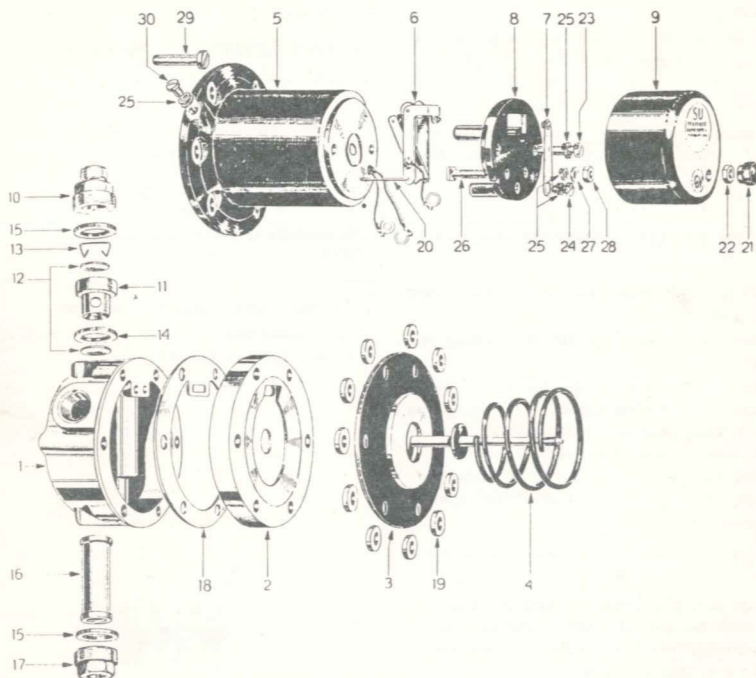

Electric fuel pump

- |                         |                           |                     |
|-------------------------|---------------------------|---------------------|
| 1. Pump body            | 11. Valve cage            | 21. Terminal nut    |
| 2. Spacer               | 12. Valve disc            | 22. Cover nut       |
| 3. Diaphragm            | 13. Spring clip           | 23. Pedestal screw  |
| 4. Volute spring        | 14. Fiber washer, thin    | 24. Screw for blade |
| 5. Magnet housing       | 15. Fiber washer, thick   | 25. Spring washer   |
| 6. Throw-over mechanism | 16. Filter                | 26. Terminal screw  |
| 7. Spring blade         | 17. Filter plug           | 27. Lead washer     |
| 8. Bakelite pedestal    | 18. Gasket                | 28. Nut             |
| 9. Bakelite cover       | 19. Armature guide roller | 29. Assembly screw  |
| 10. Outlet union        | 20. Rocker hinge pin      | 30. Ground terminal |



5. Collect eleven guide rollers 19, which will drop free as diaphragm is removed.
6. Lift diaphragm and spindle from housing and collect volute spring 4.
7. Turn pump over and remove nut 22, retaining bakelite cover 9.
8. Remove cover.
9. Back off two screws 23 holding pedestal 8 to magnet housing 5. Remove only one entirely, however — the screw to which breaker ground lead is connected.
10. Draw out rocker hinge pin 20 from bakelite molding.
11. Throw-over mechanism can now be removed sideways in opposite direction to hinge pin.
12. Back off and remove screw 24, retaining spring blade 7, and disconnect coil terminal.

Unless pedestal or entire magnet housing are to be replaced, further disassembly is unnecessary. Otherwise proceed as follows:

#### CONTACT BREAKER PEDESTAL, VALVES, ETC.

13. Back off and remove nut 28, retaining other coil lead.
14. Remove second of two screws 23, retaining pedestal.
15. Release coil terminal tag with a thin screwdriver blade inserted between the terminal tag and bakelite pedestal, or break lead washer 27 free with a knife. This washer is located between tag and nut. It has been compressed when assembled to render accidental removal of terminal unlikely.

#### WARNING

Be very careful to avoid breaking off magnet coil leads. Do not completely disassemble contact breaker molding unless necessary but rather leave one screw fitted.

16. After removal of terminal, remove screw 26 and collect spring washer 25.
17. Remove outlet union 10 from pump body.

18. Collect fiber washer 15 from under union.
19. Remove valve cage 11 and collect thin fiber washer 14 from below valve cage — it will be necessary to turn pump body upside down, so that washer 14 falls out together with suction valve disc 12.
20. Back off and remove filter plug 17 and filter 16, collecting fiber washer 15.

#### REASSEMBLY

After all parts have been cleaned and blown with compressed air, test sealing of valves and replace all defective parts. Reassemble pump as follows:

#### CONTACT BREAKER, DIAPHRAGM

1. Insert terminal screw with square head in bakelite pedestal.
2. Thread spring washer on screw.
3. Fit coil terminal tag on screw.

#### WARNING

Be careful to avoid breaking off magnet coil leads.

4. Fit lead washer, if possible a new one.
5. Screw down nut with concave side nearest lead washer, and tighten hard.

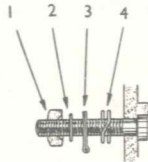

Connection of coil terminal to screw

1. Nut
2. Lead washer
3. Terminal tag
4. Spring washer



6. Fit pedestal to magnet housing with screw 23 and spring washer, but do not tighten screw yet.
7. Assemble throw-over mechanism and insert between pedestal and magnet housing. Adjust outer rocker if necessary so that no appreciable sideplay exists, nor excessive tightness. Check that ground lead is properly connected.
8. Fit other retaining screw 23 but do not tighten yet. Place ground terminal nearest screw head and fit spring washer under tag.
9. Insert rocker hinge pin, checking that center part of rocker spring points up towards contact points. Replace hinge pin only with genuine S.U. part, as it is hardened and steel wire or similar are not suitable as substitutes.
10. Check location of ground terminal and previously connected lead terminal.
11. Now tighten alternately pedestal retaining screws 23.

**WARNING**

Do not tighten excessively — the bakelite pedestal may easily be cracked.

12. Fit volute spring on diaphragm push rod, with its greater diameter away from the diaphragm. Check that the impact washer is fitted on spindle adjacent to the armature, see fig.

**NOTE**

Do not endeavor to tension the spring by stretching.

13. Pass push rod through magnet core and turn rocker trunnion so that diaphragm push rod can be screwed in a few turns.
14. Place eleven guide rollers in position around armature, inside diaphragm.

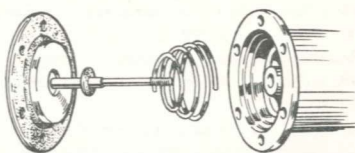

Diaphragm with volute spring and impact washer.

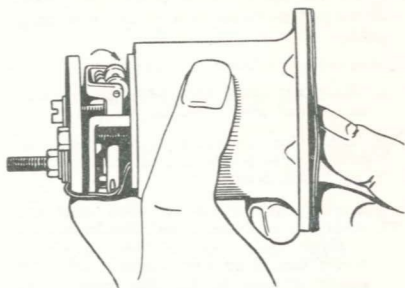

Checking armature setting

**ADJUSTMENT AND CHECKING**

15. Hold magnet assembly horizontally in left hand, see fig. Screw in diaphragm push rod, pushing in diaphragm (i.e. armature) firmly and steadily with right thumb at regular intervals. At first, breaker mechanism will throw over hard. Continue adjustment to the point where it only just throws over.
16. Now screw back the diaphragm and armature four hole gradations ( $2/3$  turn). Fit one assembly screw to prevent setting from being altered.

**NOTE**

During armature adjustment the contact blade on the pedestal should be swung to one side and a steady, even pressure must be applied — do not jerk the armature.





17. Refit the fixed contact blade hard against bakelite pedestal. Fit coil terminal tag over blade first, then spring washer.
18. Now that armature adjustment is completed, any adjustment of breaker points may be carried out.
19. Check and, if necessary, adjust spring blade so that when the contacts are separated it rests on a slight ledge formed in bakelite pedestal. However, tension in spring should not be greater than permits outer rocker to deflect it back from ledge when in contact.
20. Check that contact points coincide fully when circuit is closed. If not, adjust location of spring blade.
21. Now check the following points:
  - a. Check that spring blade rests against ledge on pedestal when contacts are open.
  - b. Check that tension of spring blade still permits outer rocker to make a full motion and deflect blade.
  - c. Contact points should close when rocker is at middle of its travel. Check this by placing a finger against spring blade, keeping it firmly against ledge in bakelite molding. Be careful to press directly over ledge — not the overhanging portion. With spring blade held thus, a clearance of approx. 0.03 in. (0.75 mm.) should be measured between magnet housing and white rocker roller, and a similar clearance between rocker and bakelite pedestal — If actual clearances are not as specified, adjust contact blade until correct readings are secured, but note that armature must be correctly adjusted first. After adjustment, repeat checks as per 19 and 21 above.
25. Place **thick** fiber washer above valve cage.
26. Screw in outlet union and tighten.
27. Fit filter and fiber washer on filter plug, screw plug in pump body and tighten.
28. Fit an undamaged gasket between pump body and spacer.
29. Place spacer so that its concave side faces towards magnet housing and holes to passages in pump body agree with corresponding holes in spacer.
30. Do not apply any form of sealing compound to diaphragm.
31. When pump body, spacer and magnet housing are assembled, the diaphragm must be flat, i.e. pressed in. This may be achieved in several ways, but best by using a wedged fork as illustrated. Insert fork between white rollers of outer rocker and press under tips of inner rocker until push-rod trunnion is lifted as far as it will go. Now fit six assembly screws in housings. Be careful not to damage the relatively delicate contact breaker mechanism.
32. When fitting magnet housing to body, see that drain hole by flange of housing coincides with filter plug.

### IMPORTANT

Make sure diaphragm is stretched to its maximum before tightening screws.

### VALVES, ETC.

22. Place suction valve disc in its seating in pump body. Turn the disc so that its **smooth face** is against seating. This also applies to delivery valve disc, if this and its spring clip have been removed from valve cage.
23. Place **thin** fiber washer in pump body below the valve cage.
24. Fit valve cage together with valve disc, retained by spring clip. Spring clip should face outwards.
33. Tighten assembly screws.
34. Remove wedged fork from rockers.
35. Lubricate rocker hinge pin with a couple of drops of oil.
36. Test pump by coupling up to a battery, being careful that hinge pin does not fall out (normally it is retained by breaker cover).
37. Fit bakelite cover.
38. Refit pump to car and check delivery pressure and also for leaks.

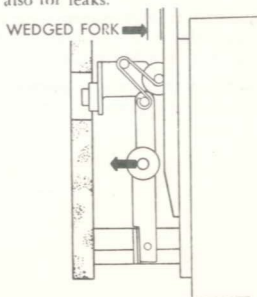

Wedged fork used to stretch pump diaphragm



## REPLACEMENT OF BREAKER CONTACTS OR DIAPHRAGM

### DISASSEMBLY

When breaker contacts or pump diaphragm are to be replaced the pump must be disassembled to allow correct readjustment. for detailed description.

1. After removing pump from car and cleaning it thoroughly, back off six screws holding magnet housing to pump body.
2. Unscrew diaphragm together with volute spring and armature guide rollers.
3. Remove bakelite cover. To replace breaker points, continue as follows:
4. Back off both screws holding pedestal to magnet housing, but remove only one of them (the one to which breaker ground lead is connected).

### NOTE

To avoid damage to the delicate coil leads, pedestal should be left in position, loosely retained by the other screw.

5. Extract hinge pin and draw out rocker assembly from side opposite to pin.
6. Back off screw retaining contact blade and remove blade.

### REASSEMBLY

After replacing contact points and/or diaphragm as required, reassemble as follows. For a detailed description

1. Insert rocker assembly between bakelite pedestal and magnet housing, and lightly screw in second pedestal screw, attaching breaker ground lead in appropriate cut-out.
2. Fit hinger pin, then tighten cautiously the bolts for the holding pedestal. Place earth lead in its cut-out.
3. Refit diaphragm with impact washer, spring and guide rollers.
4. Adjust diaphragm and contact points as described
5. After filter and valves have been cleaned and inspected, reassemble pump body and magnet housing. Stretch diaphragm before tightening screws finally.
6. Test pump by connecting it to a battery.
7. Refit pump in car and test for pressure and leaks.

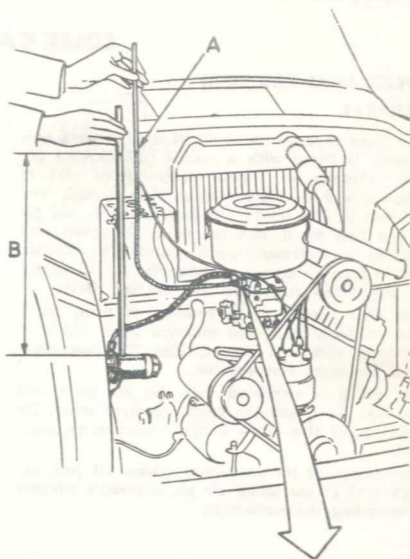

### CHECKING PUMP PRESSURE

Pump pressure is most easily checked by fixing a plastic hose to an adapted carburetor banjo union. This hose ought to be about 4 ft. (1.2 m.) long and have a bore of approx 0.2 in. (5 mm.). Drill a hole in the banjo screw, solder on a tube piece and press the hose over this. See fig.

For testing, run the engine at slow-running speed and hold the hose to measure the height of the fuel column above the pump. The level in the hose will rise and fall with each stroke. If it falls below 20 in. (500 mm.) a check of the diaphragm, volute spring, valves and washers is indicated. If it exceeds 40 in. (1 metre), there is a risk that the float level in the carburetor will be too high. Adjust the float level, therefore.

If air bubbles appear in the plastic hose, even after careful bleeding, air must be leaking into the system. First check all line connections and then the pump.

### FUEL PUMPS FOR TWIN CARBURETORS IN SAAB GT-750

If a Saab GT-750 is modified with a Solex 44 P11 twin-carburetor assembly, dual fuel pumps must also be fitted. These should be arranged in parallel as illustrated below.



## SOLEX CARBURETOR

### SOLEX 40 AI AND 40 BI

#### GENERAL

The Solex type 40 AI or 40 BI downdraught carburetor is fitted with a special cold-starting device, whereby an engine started from cold is supplied with a richer mixture than normal. The richness of this mixture is determined by air jet 8 and fuel jet 9, and the device is called into play by an instrument-panel control. The throttle should then be closed as otherwise it will partly or completely counteract the starter device.

The high speed system consists of main jet 4 and emulsion jet 1 and emulsion tube, which — correctly combined — provides the carburetor with the right compensation.

The idling is regulated with the air jet 2 and the fuel jet 3 and the volume control screw. By backing off this screw a richer mixture is obtained.

The design of the carburetor makes all jets, except that of the idling air jet, accessible without dismantling the carburetor.

#### DISASSEMBLY AND REASSEMBLY

1. Remove air cleaner.
2. Disconnect fuel line from pump.
3. Disconnect cold-start control from carburetor.
4. Remove rubber bellows from plate on throttle spindle.
5. Remove induction manifold from engine together with carburetor. Separate carburetor from manifold if required.
6. Clean carburetor externally.
7. Remove float chamber cover.
8. Check needle valve and washer.
9. Check float lever and spindle.
10. Weigh float to ensure that it is not leaking.
11. Check main jet, idling jet and emulsion tube jet.
12. Check starter slide for wear and inspect lever locating ball, starter air and fuel jets, and location of lever (return motion).
13. Check throttle spindle for wear.
14. Reassemble carburetor after cleaning all parts.
15. Remount carburetor on induction manifold and refix entire assembly on engine.
16. Reconnect controls and fuel line and start engine.
17. Check float level if required.
18. Adjust slow running speed after air cleaner has been fitted and engine warmed up.

#### IDLING ADJUSTMENT

Adjust the idling speed when the engine is warm.

1. Screw in volume control 5 to bottom position.
2. Back off volume control screw 1 1/2—2 turns.
3. Adjust idling speed with adjustment screw 6. Engine should idle at about 700—800 r.p.m.

#### ADJUSTMENT OF FLOAT LEVEL

Adjust float level after the carburetor has been installed.

1. Allow engine to idle.
2. Without touching accelerator, switch off ignition.
3. Remove air cleaner.
4. Remove fuel banjo union from carburetor. This is necessary to prevent fuel pump from filling float chamber with fuel as soon as float chamber cover is removed.
5. Back off float chamber cover screws and remove cover.
6. Measure float level with a vernier gauge, see fig. Distance between top of chamber and fuel level should be  $0.8 \pm 0.04$  in. ( $21 \pm 1$  mm.) but, if the engine is hard to start when warm, level may be lowered to  $0.85 \pm 0.02$  in. ( $22$  mm.) from top of chamber.
7. Adjust float level by filing down fiber washer under needle valve, or add another washer, as indicated. It is also possible to bend the float lever slightly, but exercise care when doing this.
8. After adjustment recheck level.

#### NOTE

Fuel pump pressure may be conveniently checked at the same time —

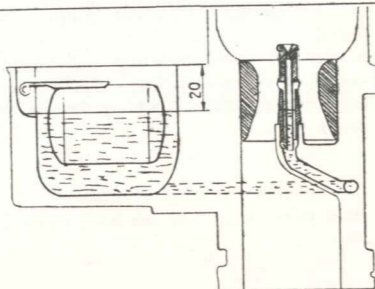

Checking float level, 0.8 in. (20 mm.)





### CLEANING OF CARBURETOR

It is not necessary to remove the carburetor for cleaning.

1. Remove air cleaner.
2. Disconnect fuel line at carburetor.
3. Clean filter in carburetor banjo union.
4. Back off four screws in float chamber cover and lift off cover. Collect gasket.
5. Clean needle valve.
6. Remove float lever spindle (screwed) and lift out float.
7. Remove main jet 1.
8. Remove auxiliary fuel jet 6.
9. Remove starter jet 9.  
All these jets may be reached easily without disassembling.
10. Blow float chamber, passages and jets clean.
11. Reassemble carburetor in reverse order. Inspect cover gasket and replace if not in perfect condition.

### TWIN CARBURETOR ASSEMBLY, SOLEX 44 PII

As competition equipment for the GT-750 a twin carburetor assembly, the Solex 44 PII, can be supplied as an optional extra. When this assembly is fitted the induction manifold and control linkage must be changed and dual, parallel-connected fuel pumps fitted. See note, below.

The twin carburetors work on the same principle as the single Solex except that no starter device is fitted.

#### IMPORTANT

The Solex 44 PII assy. is intended only for the GT-750 and involves replacement of the exhaust system with a large-bore assembly. As stated, dual fuel pumps, special induction manifold and linkage are also required.

The high noise level after this modification makes the car unsuitable for normal use.

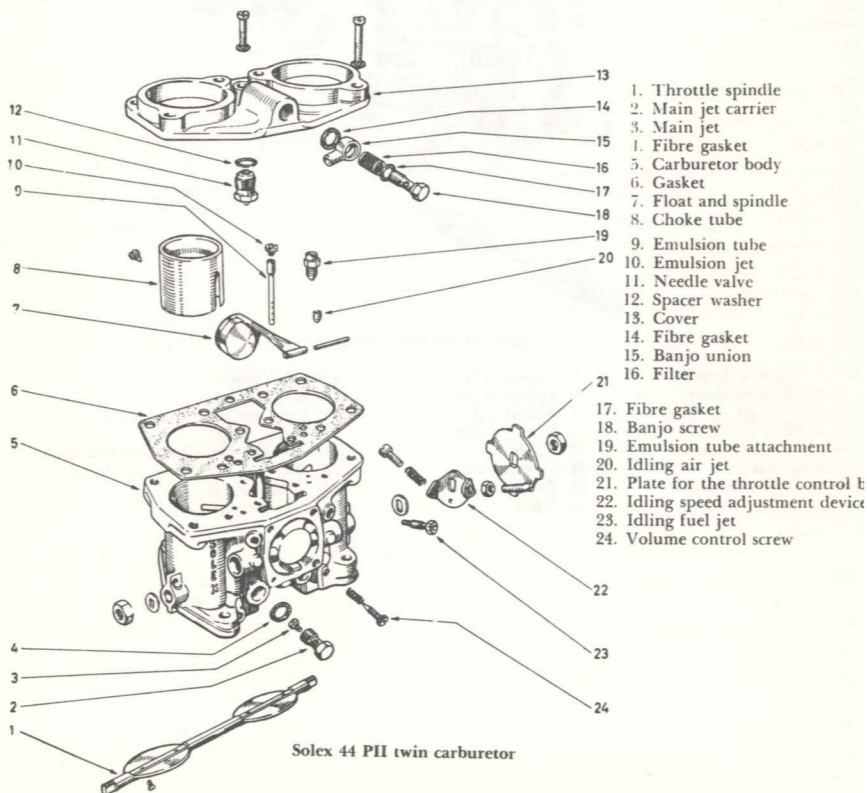



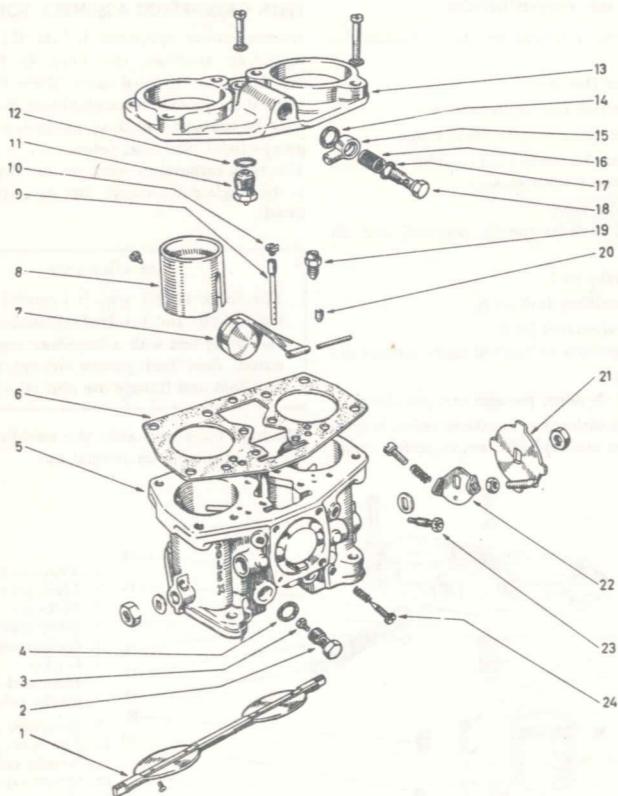

Solex 44 PII twin carburetor

- |                      |                   |  |
|----------------------|-------------------|--|
| 1. Throttle spindle  | 9. Emulsion tube  | 17. Fibre gasket                           |
| 2. Main jet carrier  | 10. Emulsion jet  | 18. Banjo screw                            |
| 3. Main jet          | 11. Needle valve  | 19. Emulsion tube attachment               |
| 4. Fibre gasket      | 12. Spacer washer | 20. Idling air jet                         |
| 5. Carburetor body   | 13. Cover         | 21. Plate for the throttle control bellows |
| 6. Gasket            | 14. Fibre gasket  | 22. Idling speed adjustment device         |
| 7. Float and spindle | 15. Banjo union   | 23. Idling fuel jet                        |
| 8. Choke tube        | 16. Filter        | 24. Volume control screw                   |



## ZENITH CARBURETOR

### GENERAL

Certain series of vehicles are fitted with Zenith 34 VNN carburetors, which differ from the Solex carburetor mainly in that the cold start device is absent, a normal choke being fitted (referred to by Zenith as a strangler flap). Pulling out the choke control closes the spring-loaded strangler flap, while simultaneously opening the throttle and automatically ensuring sufficient slow-running speed. A throttle strangler linkage actuates the throttle opening. Thus it is not necessary to touch the accelerator pedal when starting with choke. The choke control should be pushed in as soon as the engine is warm enough, however.

### DISASSEMBLY AND REASSEMBLY

1. Remove air cleaner.
2. Remove fuel pump outlet union.
3. Release choke control.
4. Remove rubber bellows from throttle spindle plate.
5. Back off nuts retaining carburetor on manifold and lift off carburetor.
6. Clean carburetor externally.
7. Back off four screws holding bowl to barrel and remove bowl. Move it first a little to the side, then down, to free emulsion block orifice.
8. Check needle valve and washer.
9. Inspect float lever and spindle.
10. Check, by weighing, that the float is not leaky.
11. Back off two screws retaining emulsion block and remove same from bowl.
12. Remove all jets.
13. Remove strangler flap and spindle.
14. Back off screw 10, fixing choke tube and remove tube.
15. Inspect all gaskets and washers and blow through all passages.
16. Reassemble carburetor and adjust fast-idle interconnection link.
17. Refit carburetor in car and adjust slow running speed when engine is warm.

### FAST-IDLE ADJUSTMENT

The fast-idle adjustment (the linkage between strangler and throttle) is set as follows:

1. Back off stop screw 1 and open throttle flap 0.043 in. (1.1 mm.) which is done by placing a piece of wire (diameter 0.043 in.) between flap and body.

2. Close strangler flap entirely and then check that throttle lever 2 rests against projection on throttle control.
3. Retighten stop screw 1, after which wire may be removed from throttle flap.

### IDLING ADJUSTMENT

Adjust the idling speed when the engine is warm.

1. Screw air-regulating screw 6 to its bottom position.
2. Back off screw 1 1/2—2 turns.
3. Adjust throttle stop screw 3 to achieve a idling speed of 700—800 r.p.m.

### FLOAT LEVEL

Float level is determined by the washer under the needle valve seating. A washer of 0.08 in. (2 mm.) thickness gives the correct level. To check the level, it is necessary to remove the carburetor bowl, as follows:

1. Allow the engine to idle and switch off ignition without touching throttle.
2. Remove fuel line banjo union from carburetor to prevent flooding from the pump.
3. Remove air cleaner.
4. Back off bowl retaining screws and remove bowl without spilling any fuel from within.
5. Measure distance from upper edge to fuel level while bowl is held horizontal. With float in position, it should be 0.89 in. (22.5 mm), or without float, 1.18 in. (30 mm).
6. The level may be lowered (measurement increased) by adding an extra washer under the valve seat, and the level may be raised by filing down the existing washer.
7. Recheck adjustment afterwards.



## AIR CLEANER

### AIR CLEANER AND AIR PREHEATER

The air cleaner is equipped with a muffler to reduce the noise of induction.

A pipe drawing heat from the exhaust manifold is connected with an induction air preheater at the air cleaner. This device is designed to prevent ice formation in the carburetor, which can occur when the ambient temperature is between 25° and 60° F, (-5 and + 15° C), and the relative humidity in excess of 55 %.

The presence of ice in the carburetor is indicated by engine stoppage at slow running speeds, increased fuel consumption and — in the worst cases — serious loss of performance.

The preheater pipe is easy to remove during consistently warm weather.

#### NOTE

Do not remove the preheater pipe unless consistently warm weather is absolutely certain.

The air cleaner comprises a replaceable filter element, which should be renewed every 18,000 miles (30,000 km.) or every second year. Protect the filter element from dampness and do not wash or oil it. Maintenance consists of wiping clean the filter body and cover at intervals and blowing the element with compressed air at times — exercising care in doing so. Be careful to prevent dust or foreign matter from falling into the carburetor.

### AIR CLEANER FOR TWIN CARBURETORS ON GT-750

When the Solex 44 PII twin-carburetor assembly is fitted on the GT-750 a special air cleaner unit incorporating two filter elements is used. These filter elements should be washed in kerosene and oiled frequently, about every 1,800 miles (3,000 km.)

## EXHAUST SYSTEM

### GENERAL

The engine exhaust system comprises the exhaust manifold, the front and rear mufflers and the exhaust pipe, arranged as illustrated.

The exhaust manifold collects the gases expelled from the cylinders and is fitted to the cylinder block using three asbestos gaskets, provided to ensure the necessary close seal. The flange of the front muffler connection pipe and the manifold are connected with a gasket between them.

The front muffler is located under the engine compartment floor pan immediately behind the front lower panel. It is an integral welded unit incorporating a system of internal bafflers and tubes.

The rear muffler is located behind the right rear wheel and is carried in rubber bushings on a bracket welded to the wheel house. This muffler, also welded, includes the short tail pipe which discharges the gases below the rear bumper.

The exhaust pipe is inserted in and clamped to the front and rear muffler pipe connections. The pipe connections are slit to give a close fit when the clamps are tightened. The clamp retaining the exhaust pipe at the floor is rubber bushed — the purpose of the bushings being to reduce pipe vibration and insulate the body panels from such vibration.

## EXHAUST MANIFOLD

### GASKETS BETWEEN MANIFOLD AND CYLINDER BLOCK

If leakage occurs between the exhaust manifold and the cylinder block check that the retaining bolts are tight. If tightening these does not stop the leakage, the gasket must be replaced. Exercise care when tightening the manifold bolts to avoid damaging the cast-iron manifold.

### GASKET BETWEEN MANIFOLD AND FRONT MUFFLER CONNECTION

If leakage occurs between the exhaust manifold and the front muffler connection, proceed as follows:

1. Release bolt retaining muffler to engine.
2. Tighten nuts on flange bolts joining muffler connection and manifold, but not excessively, since the flange is cast.
3. If leak is not remedied, replace gasket. Check at same time that there are no cracks in muffler connection flange to manifold.
4. Retighten suspension bolt.

#### NOTE

It is important to release suspension bolt during this work. Otherwise damage can occur to the muffler connection flange when nuts are tightened.



## MUFFLERS

### FRONT MUFFLER

#### REMOVAL

Jack up right side of car before starting work.

1. Release exhaust pipe clamp.
2. Back off and remove bolts joining front muffler connection to exhaust manifold. Remove gasket.
3. Back off and remove muffler hanger bolt and lower muffler below front panel.
4. Separate exhaust pipe and muffler.
5. Remove muffler.

#### INSTALLATION

1. Pass muffler connection flange through hole in engine compartment floor pan.
2. Push exhaust pipe into muffler pipe connection and fit clamp.
3. Fit hanger bolt and secure muffler without tightening hard.
4. Insert new gasket between muffler flange and exhaust manifold and secure connection.
5. Tighten hanger bolt finally. Check that muffler is positioned exactly parallel to lower front panel. Check for satisfactory clearance between muffler and engine compartment floor pan.
6. Tighten exhaust pipe clamp finally.
7. Run engine and inspect for leaks.

### REAR MUFFLER

#### REMOVAL

1. Jack up rear end of the car.
2. Remove right rear wheel and release exhaust pipe clamp.
3. Release the two upper nuts holding rear muffler to wheel house bracket.
4. Separate muffler and exhaust pipe, and remove muffler.

#### INSTALLATION

1. Push exhaust pipe into muffler pipe connection and fit clamp.
2. Fit muffler to bracket with the two rubber cushions.
3. Tighten clamp at muffler pipe connection.
4. Start engine and inspect for leaks.
5. Refit rear wheel.

### REPAIRS

The front muffler is seldom choked with carbon or other deposits, due to its location close to the engine where the temperature of the exhaust gas is fairly high. The rear muffler, on the other hand, may sometimes become choked with carbon. The problem is worst during cold periods and on cars driven frequently with over-rich mixture, i.e. at low speeds in high gear. Like the exhaust pipe, the muffler may be burnt clean. Any cracks appearing in the muffler may be repaired by welding.

### REPLACING FRONT MUFFLER CONNECTION FLANGE

If the muffler connection flange is damaged, a new welded neck flange (available as spare part) may be fitted, as follows:

1. Release flange connection and cut muffler connection pipe to suitable length.
2. Tack weld the new flange.
3. Fit muffler loosely to check that connection with exhaust manifold can be made without stressing any part. Adjust to achieve a comfortable fit.
4. Remove muffler and weld finally. Avoid leaving weld tears or blobs inside the pipe.
5. Refit muffler.

### JOINTS BETWEEN MUFFLERS AND EXHAUST PIPE

If leakage occurs at the connections between the front muffler and the exhaust pipe or between the exhaust pipe and the rear muffler, proceed as follows:

1. Release clamp —
2. Press exhaust pipe further into muffler pipe connection.
3. Check that exhaust pipe is not bent, causing stresses at connections.
4. Tighten clamp nuts and bolts.

If leaks still cause trouble, check the alignment of the pipe and straighten as necessary.

### CRACKS

Repair cracks in the exhaust pipe or mufflers by welding. Be careful that no deformation or residual stresses exist in the parts after welding.





## EXHAUST PIPE

### EXHAUST PIPE

#### REMOVAL

Jack up right side of car.

1. Remove right rear wheel and release clamp joining exhaust pipe to rear muffler.
2. Remove upper nuts holding rear muffler to bracket and pull muffler from exhaust pipe.
3. Release clamp joining exhaust pipe to front muffler.
4. Remove nuts from exhaust pipe floor clamp inside the car floor.
5. Pull exhaust pipe from front muffler.

#### INSTALLATION

Proceed as for removal, but in opposite sequence. Check that the pipe is pressed well home into muffler pipe connections to ensure good sealing when clamps are tightened. Make sure that rubber bushings at floor clamp are not under tension. If pipe is fitted under tension vibrations may occur in the body panels.

#### DECARBONIZING AND REPAIRS

After about 12,000—15,000 miles (20,000—25,000 km.), the exhaust pipe will probably be so choked with carbon deposits that a good deal of power is needed just to blow out the exhaust gases. The pipe must be decarbonized. This can be done in several ways, but the best is to burn the carbon, simultaneously blowing it clear with compressed air. This calls for considerable heating of the pipe, and care must be taken to avoid deformation.

It is normally more economical to replace the pipe, however, as it is also weakened by corrosion and dented by flying stones and gravel.

### RUBBER BUSHINGS

#### REMOVAL

Jack up right side of car and remove rear wheel.

1. Release exhaust pipe rubber bushings from car floor — the nuts can be reached from inside the car after turning back the mats.
2. Back off and remove nuts holding bushings to exhaust pipe.
3. Back off and remove nuts holding bushings to muffler. It may be necessary to remove the muffler first.

#### INSTALLATION

1. Fit exhaust pipe rubber bushings under floor.
2. Attach muffler rubber bushings to rear muffler.
3. Refit muffler and bushings to wheel house bracket.
4. Refit exhaust pipe floor clamp over bushings.

Check that no stresses have been introduced.



## DESCRIPTION

### GENERAL

The Saab engine is water cooled. The cooling system comprises the engine water jacket, radiator, pump, thermostat and hoses, in addition to which there is an engine-driven fan which forces air through the radiator.

The fresh-air heater for the passenger compartment is directly connected to the cooling system.

The radiator consists of upper and lower tanks interconnected by a tubular-type core. The radiator is fitted with a pressure cap, permitting very high coolant temperatures (200° F or 95° C and even higher) to be maintained without appreciable loss of water from the system.

The water pump, of centrifugal type, is integral with the generator, the pump impeller being carried on an extension of the generator shaft.

An aneroid-type thermostat is fitted, alternative settings providing for opening at approx. 185° or 170° F (85° or 75° C). On the inlet side of the thermostat there is a connection for the by-pass line, connected in parallel with the radiator. The water flows through this line until the thermostat opens.

The engine-driven fan is located immediately in front of the radiator. The fan shaft is carried in two ball bearings housed in a bracket fitted to the cylinder head.

## RADIATOR

### REMOVAL

Always handle the radiator carefully, to avoid damage and leaks.

1. Drain off water.
2. Release hose clamps from radiator and pull hoses free.
3. Back off two bolts retaining radiator to radiator frame.
4. Release radiator stay from frame. Bend frame forward carefully to permit extraction of stay from its hole in frame.
5. Back off two bolts holding radiator to support member.
6. Press frame forward carefully and move radiator backwards until inlet connection clears frame and radiator can be lifted out behind frame, as illustrated.

### INSPECTION AND SEALING

Check that the radiator does not leak: for example, by plugging pipe connections, lowering it into water and testing with compressed air, max. pressure 14.7 psi. (1 atmos.).

A leaky radiator may be repaired by soldering. Avoid using patent sealer additives in the water except where no other remedy is available. These additives can choke jackets and hoses and reduce circulation.

The cells of the radiator core may be so choked with dust, insects, etc., that air flow is reduced. The core must therefore be washed and blown clear with compressed air at intervals.

### INSTALLATION

1. Replace radiator in correct position and relocate stay in frame. Bolt radiator to support member and frame.
2. Tighten nut on radiator stay.
3. Reconnect hoses. Check that they are free from kinks; and refit clamps.

## WATER PUMP

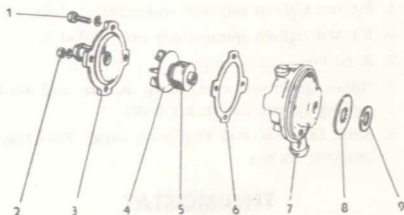

Water pump, removed from generator

1. Bolt
2. Nut
3. Pump cover
4. Pump impeller
5. Shaft seal
6. Gasket
7. Pump body
8. Splash washer, brass
9. Shim



## REMOVAL

1. Drain off water.
2. Release generator adjustment and retaining bolts and lift fan belt from generator pulley.
3. Release hose clamps at pump and pull hoses free.
4. Disconnect generator cables and lift generator and pump from car. Always remove generator pump from car when working on pump, as this greatly simplifies operations.
5. Remove pump cover 3 by backing off two bolts 1 and nuts 2, fixing cover to body 7.
6. Unscrew impeller 4 from generator shaft.
7. Remove pump body 7.
8. Remove splash washer 8 from generator shaft. Collect shim 9 from behind splash washer.
9. If necessary, remove shaft seal 5 from impeller shaft, where it is press fitted.

## INSTALLATION

1. After thoroughly cleaning and inspecting all parts, fit shim 9 on generator shaft.
2. Fit washer 8 on generator shaft.
3. Locate pump body against generator, with outlet connection in correct position.
4. Press seal 5 into impeller shaft. Use a driver sleeve with a .6 in. (15.1 mm.) hole to avoid damage to seal. If impeller is damaged, replace it with an impeller assy. with ready-fitted seal.
5. Fit and tighten impeller to generator shaft.
6. Fit and tighten pump cover over gasket 6.
7. Refit hoses and clamps.
8. Install generator and pump in car and refill cooling system. Check for leaks.
9. Refit fan belt and re-tension same. Reconnect generator cables.

## THERMOSTAT

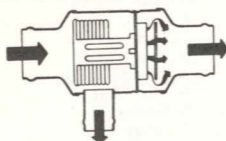

Thermostat: Flow diagram

## GENERAL

Engine temperature is regulated by a thermostat fitted in the water hose between the engine outlet and radiator inlet. The thermostat, illustrated above, is of aneroid type. Two models are available, one set to open at 185° F (85° C) and intended for the Saab 95 and 96; and another set to open at 170° F (75° C) for the GT-750. On some export markets all vehicles are fitted with the 170° F (75° C) type, and on other markets an empty housing without aneroid body may be fitted. It is important that the thermostat be correctly positioned, as illustrated.

## TESTING THERMOSTAT OPERATION

To test for correct thermostat operation, proceed as follows:

1. Suspend thermostat in a container of water, clear of bottom.
2. Heat container over a hotplate, keeping a check on temperature and observing thermostat valve.
3. a) The 185° F, 85° C thermostat should not open before 180° F, and 82° C, and it should be fully open at 200° F, 95° C.  
b) The 170° F, 77° C thermostat should not open before 163° F, 73° C and should be fully open at 183° F.  
Full opening is 0.21 in. (5.5 mm.),
4. A faulty thermostat must be replaced.

## CLEANING THE SYSTEM

### CLEANING

The cooling system should be drained twice a year (spring and autumn, in temperate climates.) Clean the system thoroughly before refilling.

1. Drain off water.
2. Flush system with clean water.
3. Fill system with clean water to which has been added a suitable commercial solvent. Follow manufacturer's instructions.
4. Shield radiator from fan blast and run engine until warm.
5. Stop engine and, after a few minutes' pause, drain off water.
6. Flush system once more with clean water, treating engine jacket and radiator separately after releasing clamps and removing hoses. Flush this time against normal direction of flow, that is, so that water enters engine jacket at top and radiator system at bottom.
7. Clean and inspect pump.
8. Clean and check operation of valve in heater



## FAN AND FAN SHAFT BEARING STAND

## GENERAL

The fan shaft is carried in two ball bearings housed in a special stand. The ball bearings are provided with labyrinth seals comprising two plastic washers and two metal washers. The shaft is positioned longitudinally by shims.

If correctly fitted, it should be possible to press the bearings into the bracket housings by thumb pressure. If this is not possible, polish the bearing seats to improve the fit. Check that the various seal washers are fitted in the correct order as illustrated, and that the plastic washers are not deformed. Adjust with shims to obtain an end float of maximum .012 in. (0.3 mm.).

## NOTE

On a limited number of cars the bearing seals consist of a felt ring in a retainer. When overhauling such bearing assemblies, replace the felt seal with a labyrinth seal. The coil spring fitted on the shaft at the belt pulley end should then be removed.

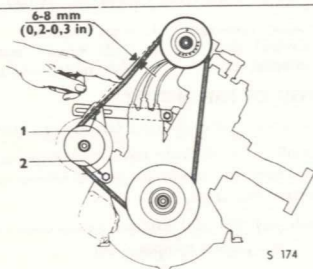

## Adjustment of belt tension

1. Adjustment bolt
2. Fixing bolts

## REMOVAL AND DISASSEMBLY

1. Remove induction muffler with air cleaner and preheater.
2. Loosen generator adjustment and fixing bolts, and lift fan belt from pulley.
3. Remove shaft bearing stand from cylinder head.
4. Back off shaft nuts at fan and pulley ends.
5. Pull fan and pulley from shaft, and collect Woodruff keys.
6. Remove retainers from both ends of bearing tube.
7. Drive shaft out of tube, towards pulley end.
8. Remove seal assemblies and bearings from shaft.
9. Remove seal assemblies and ball bearings from tube.

## REASSEMBLY AND INSTALLATION

Clean and inspect all parts before reassembly. Replace defective parts.

1. Check that ball bearings can be fitted in fan bearing bracket by thumb pressure. If not, polish the bearing seats to improve the fit.
2. Clean out space inside of ball bearings and fill with ball bearing grease. Pack ball bearings with similar grease.
3. Press ball bearing at pulley end onto shaft.
4. Pass shaft and ball bearing into bearing tube.
5. Locate seal outside of bearings as illustrated.
6. Fit retainer.
7. Press ball bearing on other end of shaft, next

fitting shaft seals, shims and retainer. Check that longitudinal clearance is not more than .012 in. (0.3 mm).

8. Fit Woodruff keys in shaft grooves and press fan and pulley on shaft. Fit spring washers and tighten nuts.
9. Refit bearing stand to cylinder head.
10. Refit fan belt and tension by adjusting generator, after which generator bolts may be tightened. If tension is correct it will be possible to depress belt 1/4—5/16 in. (6—8 mm.) by finger pressure.
11. Refit induction muffler with air cleaner and preheater.

## FRESH AIR HEATER

## GENERAL

The fresh-air heater is a separate system but is connected to the cooling system.

Through the intake 1, in front of the windshield air enters a collection chamber 11 formed by the body metalwork. In front of this chamber, in the engine compartment, the heat exchanger 7 is located in a metal casing. The heat exchanger is transferring heat from the cooling water to the incoming air. The temperature of the heater is regulated by a control connected to valve 3 in the engine by-pass hose, which is connected to the heater. The air leaving the heater passes to the inside of the car through a casing 6 enclosing the fan and incorporating two dampers. The first of these, 4, regulates the flow of air while the other, 2, is located in the distribution chamber 17 (in the casing, immediately above the accelerator pedal) and regulates the distribution of the admitted air. The air may be directed





ted towards car floor or up through a hose 8 to the defroster duct 9, from which it escapes through an air jet on each side up to the windshield 15, and also towards the side windows through a hole in each side of the instrument panel 16.

(From chassis No. 129.101 through defroster jets.)

At speeds in excess of about 30 m.p.h. (50 km/h), a forced draught is generated which is normally sufficient to enable the air heater to function satisfactorily. Thus the fan need only be used when the car is stopped or moving at low speed. When driving slowly during hot summer days you can add to the riding comfort by letting the fan convey fresh air into the car. When doing

so, the temperature control must — naturally — be set on "cold".

From chassis No. 168.001 the fan housing has been modified and a thermostat controlled valve introduced. In this connection also the controls have been altered. In other respects, the fresh-air heater is functioning as before.

See figures, how to use the controls.

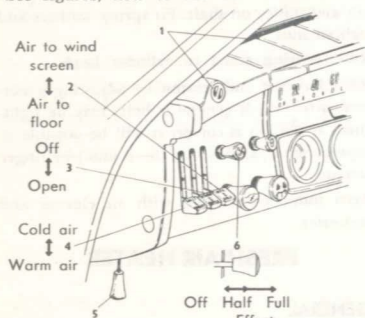

Heater controls up to and incl. chassis No. 168.000

- |                       |                         |
|-----------------------|-------------------------|
| 1. Defroster openings | 4. Heat control         |
| 2. Air distributor    | 5. Grill screen control |
| 3. Air control        | 6. Fan motor switch     |

### REMOVAL OF HEAT EXCHANGER

1. Open hood and set hood lock handle to closed position, i.e. to left.
2. Drain off water and release both hoses from the heat exchanger.
3. Back out coach screws retaining heater casing to cowl plate permitting casing and contained exchanger to be lifted forwards and upwards, out of car. NOTE: Hood lock must be closed.
4. Collect two split rubber washers fitted in recess for hood lock in casing.

5. Release screws and wire retaining the in-casing and lift out the exchanger.

Install heat exchanger in reverse sequence. After refitting, fill system with water and check hose connections for leaks.

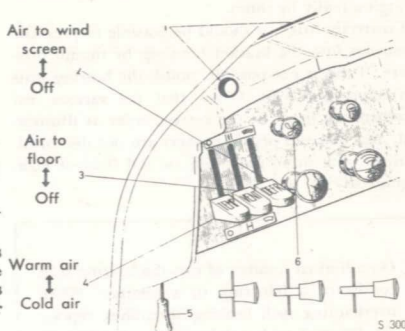

### Heater controls from chassis No. 168.001

- |                           |                         |
|---------------------------|-------------------------|
| 1. Defroster openings     | 4. Heat control         |
| 2. Air control, defroster | 5. Grill screen control |
| 3. Air control, floor     | 6. Fan motor switch     |

### REMOVAL OF FAN MOTOR

1. Open hood and disconnect fan motor cables.
2. Back off screws in front cover of fan casing, and lower cover and motor to permit release of fan impeller from shaft.
3. Detach impeller and lift out motor with casing cover from engine compartment.
4. Remove fan impeller.
5. Back off screws fixing motor to front casing cover.

Install fan motor in reverse sequence. Check before installation that motor ground lead makes satisfactory contact.

During above work, check also functioning of fresh-air heater controls and adjust and lubricate as necessary.



## DESCRIPTION

### GENERAL

All four wheels have coil springs. Each front wheel is attached to the steering knuckle, which is suspended by ball joints in two forked, transverse control arms. The inner ends of these control arms are carried in rubber-insulated bearings on the body and the vertical travel of the wheels is limited by rubber bumpers.

### FRONT AXLE

The front axle is divided into left and right hand units. A large, forged steering knuckle provides a frame for the front axle and consists primarily of a bearing housing and two inward-inclined arms — an upper and a lower. The outer drive shaft is carried in a ball bearing enclosed by the bearing housing. The wheel hub and brake drum are fitted to the tapered end of the outer drive shaft, while the brake back plate with associated brake components are bolted to the steering knuckle.

Ball joints attached to the knuckle arms provide flexible connection for the ends of the control arms. The steering arm, to which the tie rod is connected, projects from the upper knuckle arm. Movement of the steering wheel causes rotation of the steering knuckle, wheel hub and wheel about an axis (the king-pin axis) passing through the centers of both ball joints and cutting the ground plane near the center line of the wheel. Outer and inner drive shafts are connected at the universal joint, the turning center of which lies on the above-mentioned king-pin axis. A rubber bellows prevents dirt from reaching the universal joint and retains lubricant for same. The other end of the inner drive shaft is splined to the inner universal joint, fitted to the differential output shaft.

### FRONT SUSPENSION

The front axle assemblies on each side are connected to ball joints, forming the ends of the control arms. There are two control arms on each side and each of these is attached to the body through rubber-bushed mounting brackets.

The upper suspension arms incorporate seats for the coil springs, the upper ends of which are attached to similar seats on the body. These latter seats are fitted with rubber bumpers, which act as stops in case the suspension should bottom and limit upward travel. Rebound travel is limited by two rubber bumpers attached to the body below the upper control arms.

The two lower suspension arms are mutually con-

nected by a stabilizer bar. The stabilizer bar is fixed to the body by two rubber mounting brackets under the engine space floor pan and to the lower control arms by rubberized connections.

Shock absorbers, are of hydraulic telescopic type. They are attached through rubberized connections at their tops to the body; and at their bottoms to the lower control arms.

## DISASSEMBLY AND REASSEMBLY

### DISASSEMBLY

1. Raise and support front of car and remove wheels.
2. Remove shock absorbers.
3. Remove tie rod ends from steering arms, using tool 784004.
4. Detach brake hose from body.
5. Remove steering arm and upper ball joint from steering knuckle.
6. Back off clamp bolt holding lower ball joint to knuckle.
7. Pull out drive shaft from inner universal joint and lift down whole front axle unit. Wash parts thoroughly.
8. Remove coil springs
9. Remove upper and lower control arms as described in
10. Remove stabilizer bar by unbolting connection to body. Nuts are accessible from engine space. Detach both body and end mounting brackets from stabilizer bar, after which it may be pulled out to the right.
11. Remove rebound rubber bumpers.

### NOTE

When overhauling front suspension it is also advisable to disassemble and adjust steering gear as well.

### REASSEMBLY

Clean all parts thoroughly. Inspect them carefully for damage or wear and replace as required unless it is possible to adjust in accordance with instructions. for adjustment of steering gear.

1. Insert stabilizer bar from right side and bolt it to body.



2. Reassemble steering gear, if removed.
3. **Replace upper and lower control arms,**
4. Replace coil springs.
5. Replace front axle assemblies, lubricating splines of inner drive shaft with graphite grease or chassis grease. Do not forget to secure upper clamp bolts for ball joints with lock washers.
6. Replace shock absorbers.
7. Replace wheels and lower the car. Adjust brake shoes.
8. Check front wheel alignment, adjust if necessary  
Give car test run.
5. Back off and remove two bolts securing ball joint to upper control arm; remove lower spring seat.
6. Remove the compressed spring.
7. Inspect rubber washer in spring seat and replace if necessary.
8. Inspect the two rubber bumpers under upper suspension arm, constituting rebound travel limit, and replace these if necessary.

#### NOTE

If the upper rubber bumper cannot be removed because the screw has corroded, the spring can be removed by cutting away the **rebound bumpers so that the control arm is able to drop towards the supporting plates.**

#### NOTE

1. Protect rubber bushings from rubber solvents such as grease, gasoline, etc.
2. A rubber bushing that is held by corrosion is no longer fit for use, but should **nonetheless** be removed with care, so that the metal surface is not damaged. This is specially **important with bushings in the control arm connections.** After removal of the bushing, clean the contact surfaces with fine-grade emery cloth.
3. Elastic stop nuts may lose their locking power after repeated backing off and tightening. They should be replaced.

## SPRINGS AND RUBBER BUMPERS

### REPLACING COIL SPRINGS

As previously mentioned, coil springs are fitted at all four wheels. The front and rear springs must on no account be confused since the rear springs are shorter and much softer than the front springs.

The two types are most easily distinguished by their length.

When supplied, the springs are well protected **against corrosion. If the finish has been damaged,** touch it up before fitting the spring.

#### DISASSEMBLY

1. Jack up front of car and remove wheel.
2. Insert a suitable tool (Polygrip or similar) in spring and release rubber insert from bumper, which may be allowed to drop inside spring. See note below.
3. Remove shock absorber.
4. Compress spring with help of spring clamp, tool No. 784082, see illustration.

#### REASSEMBLY

1. Compress coil spring with compressor tool, No. 784081.
2. Apply spring clamp, No. 784082, and remove spring from compressor.
3. Check that rubber and metal washers are fitted in upper spring seat, also that rubber rebound bumpers are fitted under upper control arm.
4. Place spring in upper seat, at same time inserting upper rubber bumper inside spring.
5. Introduce lower spring seat between spring and control arm, and replace ball joint.
6. Back off spring clamp screws successively until tool can be removed.
7. Screw upper rubber bumper in position.
8. Replace shock absorber.
9. Replace wheel and lower the car.

## SHOCK ABSORBERS

### REPLACING SHOCK ABSORBERS

Faulty shock absorbers must be replaced. This is particularly important since the shock absorbers greatly affect the roadability and steering qualities of the car.

#### DISASSEMBLY

1. Jack up car and remove wheel.
2. Remove shock absorber, taking good care of washers and rubber items.





### REASSEMBLY

Before reassembling replace any defective rubber parts.

When fitting a shock absorber only genuine rubber bushings should be used as wrong parts may cause noise. Air must be expelled from the shock absorber before replacing. To do this, hold the shock absorber in position similar to that it has on the car and pump it for several full strokes. Fit the shock absorber to the car at once — if it is allowed to lie horizontally again air may re-enter.

1. Assemble rubber bushings and washers and replace shock absorber. Grease pin threads before fixing nuts. Tighten nuts hard.
2. Replace wheel and lower the car.

### CONTROL ARMS AND BEARINGS

#### REPLACING UPPER SUSPENSION ARM

##### DISASSEMBLY

1. Jack up front of car and remove wheel.
2. Remove shock absorber.
3. Compress coil spring, using clamp, tool No. 784082.
4. Back off and remove two bolts holding ball joint and lower springs seat to upper control arm.
5. Back off bolts securing control arm bearing brackets.
6. Remove the compressed coil spring.
7. Remove control arm bearing brackets, taking care not to mislay shims inserted under brackets.
8. Remove both nuts from pivot pin, permitting disassembly of brackets and bushings from control arm.
9. The rubber bushing in the bracket may consist of one altern. two parts. For removal of the one-piece bushing, use tool 784133 for the upper, and tool 784134 for the lower one.

##### REASSEMBLY

Clean all parts thoroughly before refitting and replace any worn or damaged items with new parts.

##### NOTE

Under no circumstances may oil or grease be used when refitting rubber bushings. If lubrication is needed, use soft soap and water.

1. Fit rubber bushings into brackets. There are two types of bushings: the one-piece and the two-parts resp. The one-piece bushing is pressed into the brackets with tools 784133 and 784134. Before fitting, smear bushing with soapy water.
2. Reassemble suspension arm and bearing brackets inserting rubber bushings. After tightening and locking both nuts, the angle between control arm and bracket should be  $70^{\circ} \pm 2^{\circ}$ , see fig.
3. Place control arm in position but do not insert bracket bolts to body.
4. Check that rubber and metal washers in upper spring seat are in place, also that rubber bumpers under control arm are fitted.
5. Insert compressed spring in its position and bolt ball joint and lower spring seat to control arm.
6. Insert and tighten control arm bearing bracket bolts. Do not forget to insert shims.
7. Back off spring clamp screws successively until tool can be removed.
8. Replace shock absorber.
9. Replace wheel and lower car to ground.
10. Give car test run, checking and adjusting wheel alignment as described in Correct settings are given in Technical Information.

#### REPLACEMENT OF LOWER CONTROL ARM

##### DISASSEMBLY

1. Jack up car and remove wheel.
2. Back off lower shock absorber connection.
3. Back off and remove two bolts securing joint to control arm, incidentally releasing stabilizer bar bearing.
4. Back off nuts in engine space securing bearing brackets to floor pan. Remove bearing brackets and control arm.
5. Remove both nuts from pivot pin, permitting disassembly of brackets and bushings from arm.

##### REASSEMBLY

Clean all parts thoroughly before refitting and replace any worn or damaged items with new parts.

##### NOTE

Under no circumstances may oil or grease be used when refitting rubber bushings. If lubrication is needed, use soft soap and water.





1. Reassemble control arm and bearing brackets, inserting rubber bushings. After tightening and locking of both nuts, angle between suspension arm and brackets should be  $0^\circ \pm 2^\circ$ .
2. Replace control arm by bolting bearing bracket to body.
3. Bolt ball joint and stabilizer bar bearing to control arm. Do not omit to insert stiffening washers on the rear of control arm.
4. Replace lower shock absorber connection.
5. Replace wheel and lower car to ground.
6. Give car a short test run.
7. Check and adjust wheel alignment as necessary, as described in Correct settings are given in Section I, Technical Information.

### ADJUSTMENT OF SUSPENSION ARMS

Carefully inspect the arms for signs of fracture or deformation if they have been subjected to severe stress, as in a collision. Deformed arms must be replaced with new ones.

## BALL JOINTS

### REPLACEMENT OF BALL JOINTS

1. Jack up car and remove wheel. Wash ball joint and adjacent parts carefully.
2. If the upper ball joint is to be replaced, compress spring with help of tool No. 784082, spring clamp.
3. Remove ball joint from steering knuckle. Upper ball joint has two bolts, the lower has one.
4. Remove ball joint from control arm.
5. Fit a new ball joint and attach pivot pin to steering knuckle and secure bolts.
6. Reconnect ball joint to control arm and release spring clamp.
7. Replace wheel and lower car to ground.

#### NOTE

Ball joints cannot be disassembled. If damaged, a complete new unit must be fitted.

### REPLACEMENT OF BALL JOINT RUBBER BELLOWS

Ball joints are protected against dirt by rubber dust excluders of bellows type. These must be replaced if damaged.

### TIGHTENING OF CONTROL ARM BALL JOINTS

Excessive free play in the control arm ball joints must be corrected, otherwise the steering qualities of the car will be affected and noisy operation will result.

1. Jack up car and remove wheel. Wash ball joint and adjacent parts.
2. Remove ball joint from steering knuckle. Upper ball joint has two bolts, the lower has one. Clean ball joint thoroughly and remove rubber bellows.
3. Using a drift, release securing flange of adjusting cap.
4. Turn cap with a suitable tool until ball joint feels slightly stiff.

#### NOTE

Do not tighten the ball joint excessively. It should be possible to move it fully in any direction by hand.

5. Secure adjusting cap by bending down flange with a drift into grooves on both sides. Be careful to secure setting properly, making new grooves if existing ones are not suitably placed. Apply grease generously to ball joint.
6. Fit new rubber bellows, replace ball joint on steering knuckle and secure bolts.
7. Replace wheel and lower car.

## FRONT WHEEL BEARINGS

### REPLACEMENT OF FRONT WHEEL HUB BEARINGS

Wheel hub bearings may become worn after considerable mileage, especially if lubrication has not been satisfactory. Play thus arising will adversely affect the steering qualities and the bearings must be replaced. To check play in a wheel bearing jack up the car and grip the wheel at top and bottom.

Try to joggle the wheel: any excessive play in the bearing will be immediately detected. If it exceeds 0.08 in. (2 mm) as measured at the wheel rim, replace the bearing. Note that in addition to special tools mentioned in this section, an arbor press will also be required. Never strike the hub bearing. It is easily damaged.

**DISSASSEMBLY**

1. Jack up car and remove wheel.
2. Remove cotter pin castle nut and washer.
3. Remove brake drum with puller 784002.
4. Release brake hose from body if necessary. Avoid this if possible, however, by removing back plate and brake assy. from steering knuckle and hanging it up nearby.
5. Remove steering arm and upper ball joint from steering knuckle.
6. Back off clamp bolt securing lower ball joint to steering knuckle.
7. Extract drive shaft from inner joint and remove entire front axle assembly; clean assy. thoroughly.
8. Release clamp and slide back rubber bellows, see fig. Remove outer pin from universal joint and remove inner drive shaft with joint and rubber bellows.
9. Remove nut and shaft seal. Release locking of nut with a drift and unscrew using the wrench 784020.
10. Remove Woodruff keys.
11. Remove outer drive shaft by pressing on threaded end. This also ejects the fifteen springs, washer and spring cup.
12. Press ball bearing out of steering knuckle.
13. Remove both seal rings from their seats if replacement is necessary.

**REASSEMBLY**

Clean all parts thoroughly and replace any worn or damaged parts with new items. Pay special attention to shaft seals and rubber bellows.

1. If seal ring in steering knuckle has been removed, fit a new one.
2. Pack new ball bearing with grease, Use only genuine parts.
3. Press ball bearing into steering knuckle with marking on inner ring facing outwards, or with the ball insert notches facing inwards. Use tool No. 784075.
4. Replace nut together with shaft seal. Secure nut.
5. Assemble the fifteen small springs, washer and cup on outer drive shaft.
6. Press shaft into knuckle until distance from outside face of ball bearing to outer end of shaft is 2.6 in. (66 mm).

7. Attach universal joint with pin and secure same.
8. Pack outer universal joint with chassis or universal grease.
9. Slide rubber bellows over joint and secure with clamp to steering knuckle.
10. Grease splines of inner drive shaft with graphite or chassis grease and insert shaft into inner joint.
11. Bolt steering knuckle to steering arm and ball joints. Do not fail to insert a lock washer at clamp bolts and secure bolts with this.
12. Replace brake back plate and drum. When refitting drum check to see that Woodruff keys are correctly located and that bearing surface against shaft seal is undamaged. If surface is damaged, restore smoothness and polish with very fine emery cloth. Coat bearing surface with ball-bearing grease.
13. Torque castle nut with 125—145 ft.-lb. (17—20 kpm) and secure with cotter pin.
14. Replace wheel and lower car to floor.
15. Adjust brake shoes, Bleed brake system if a brake hose has been disconnected.

**STABILIZER BAR****REPLACEMENT OF STABILIZER BAR**

1. Jack up front of car and remove both wheels.
2. Remove stabilizer bar by disconnecting mounting brackets from body. Bracket bolts are accessible from engine space. Remove rubber bearings and brackets from the bar and pull it out to the right.
3. Insert new bar from right, replace bearings and brackets and bolt brackets to body.
4. Connect end bearings to control arms. Remember to fit the washers at rear of arms.
5. Replace wheels and lower car.

**REPLACEMENT OF RUBBER BUSHINGS ON STABILIZER BAR**

It is possible to replace rubber bushings on stabilizer bar without removing stabilizer bar from car.

1. Jack up front of car and remove both wheels.
2. Back off and remove two bolts on each side holding ball joints and stabilizer bar brackets to lower control arms.
3. Remove stabilizer end brackets from control arms.
4. Twist bar downwards and remove end brackets and rubber bushings.



- Back off nuts (accessible from engine space) and remove one mounting bracket.
- Fit new rubber bushing in mounting bracket and replace same.
- Repeat procedure as in 5 and 6, for other mounting bracket.
- Fit new rubber bushings in both end brackets.
- Replace both end brackets on stabilizer bar.
- Reconnect stabilizer bar end brackets and ball joints to lower control arms and tighten bolts. Remember to fit reinforcements at rear of arms.
- Replace wheels and lower car to floor.

## FRONT WHEEL ALIGNMENT

### GENERAL

It is most important that the front wheels be correctly aligned, since incorrect steering geometry can cause:

- Driving fatigue, due to impaired roadability.
- Difficulties in controlling car.
- Increased tire and other maintenance charges due to abnormal wear of tires and steering assembly.

If there is reason to suspect incorrect alignment resulting from an accident, for example, or if road behaviour is noticeably impaired, the car must be inspected and adjusted immediately at an authorized shop. Furthermore, even when no particular alignment fault is suspected, the car should be checked regularly and adjusted when necessary. The settings which directly affect the front wheel alignment, and which are all interrelated, are as follows:

- King-pin inclination
- Caster
- Camber
- Toe-in
- Turning angles

### CHECKING AND ADJUSTMENT

If incorrect front wheel alignment is suspected, normally indicated as stated above by abnormal tire wear, impaired steering and roadability, etc., an alignment check should be carried out. Before commencing note the following:

- Tire pressure should be correct and front tires must not be too unevenly worn.
- Check front wheel bearings, control arm bearings, ball joints and tie rod ends, adjusting or replacing as necessary in order to eliminate faults arising from these sources.

- Check steering gear and eliminate any faults,
- Inspect shock absorbers for correct action and replace damaged shock absorbers and rubber bushings.
- If the car has been involved in an accident, damage arising therefrom must be repaired before the alignment check. Distorted steering arms must be replaced — it is forbidden to use re-straightened arms.
- Immediately prior to the check drive the car with normal suspension movement but avoiding hard cornering, inducing it to settle in its normal position. The car should also be rocked lightly a few times.

During the alignment check, the car must be empty and standing on a flat, perfectly horizontal floor. Otherwise measurements will not be reliable.

For correct settings Adjustment with shims must be within reasonable limits. Deformation resulting from crash damage or other accidents must be corrected by a full realignment of the bodywork. Deformed control arms must be replaced with new ones.

### NOTE

When using axle-fitted alignment tools on front-wheel drive cars the wheels must be standing on turntables or other suitable arrangement (such as a Wee Gee board), and should be locked with the brakes during the check.

### TOE-IN

Viewed from above, the wheels must stand in definite relationship to one another, expressed as the difference between dimensions A and B, measured rim-to-rim at axle height,

When A is less than B the wheels are said to be set with toe-in. When A is greater than B they are said to be set with toe-out.

Toe-in or toe-out is expressed in inches or mm., being — as stated — the difference between these two measurements. Thus, if there is neither toe-in nor toe-out and the wheels are parallel, the difference will be 0.

Correct setting is 0.08 in. (2 mm) toe-in, i.e.  $B-A = 0.08 \text{ in. (2 mm)} \pm 0.04 \text{ in. (1 mm)}$ . In other words measurement A must be 0.04 in.—0.12 in. (1—3 mm) less than B.

### CHECKING AND ADJUSTMENT

Check toe-in first.

- Roll car slowly straight forward on a level floor and stop it without using brakes. Do not move car backwards again.





2. Check dimensions using a special rule, tool No. 784001, measuring between rims at axle height. Roll car forward again and measure at various points on rims to avoid faults due to these being out of true. Adjust length of tie rods if necessary.
3. Loosen lock nut at tie rod end.
4. Set a wrench on flats of tie rod and turn to left or right until correct toe-in is achieved.

**NOTE**

If the rubber bellows is so tightly clamped to tie rod that it follows round when rod is turned, slacken clamp ring a little.

If toe-in is correct and when both wheels are at the center position, the tie rods should be of equal length, or so set that the wheels will have the same clearance from fenders and wheelhouse when turned hard right or left. The steering wheel spokes should be horizontal when the wheels are centered. Do not fail to retighten tie-rod locknuts after adjustment.

**NOTE**

After toe-in has been adjusted, dimension A (below) must on no condition exceed 1 5/8 in. (40 mm.). Difference between A for the two tie rods shall not exceed 0.08 in. (2 mm).

**CAMBER**

Camber is the tilt of the front wheels at the top, see fig. If both wheels tilt outwards, camber is positive (+), if they tilt inwards, it is negative (-). Correct camber for a Saab is  $3/4^{\circ} \pm 1/4^{\circ}$  positive.

**CHECKING AND ADJUSTMENT**

Camber (and also king-pin inclination) may be adjusted by inserting shims under the bearing brackets of the upper control arms, varying the number of shims until setting is correct.

Increasing the thickness of shims under both brackets by 0.1 in. (2.5 mm) reduces camber by approx.  $1/2^{\circ}$ .

If, on the contrary, a 0.1 in. (2.5 mm) shim is removed from under each bracket, the camber is increased by approx.  $1/2^{\circ}$ .

The change of shim thickness must be equal under both brackets.

**CASTER**

Caster is the inclination of the kingpin axis when viewed from the side and is usually expressed in degrees. Caster varies greatly between different makes, but usually the king pin is inclined to the rear, as illustrated, and is then called positive (+). Conversely, a forward inclination is termed negative (-), and no inclination at all means that the king pin or king-pin axis is vertical. On the Saab, caster should be  $2^{\circ} \pm 1/2^{\circ}$  positive.

**CHECKING AND ADJUSTMENT**

Caster may be adjusted by means of shims under the bearing brackets of the upper control arms.

Moving one 0.02 in. (0.5-mm) shim from under the front bracket to under the rear bracket increases the caster by  $1/2^{\circ}$ .

Similarly, moving one 0.02 in. (0.5-mm) shim from rear to front bracket decreases the caster by  $1/2^{\circ}$ .

The same thickness of shims as is removed from under one bracket must always be placed under the other, otherwise the camber will change.

**KING-PIN INCLINATION**

Actually there is no king-pin on the Saab but the term is applied to the inclination of the imaginary axis passing through ball-joint centers and cutting the ground plane near the wheel center line. Correct inclination is  $7^{\circ} \pm 1^{\circ}$ .

**CHECKING AND ADJUSTMENT**

King-pin inclination is corrected at the same time as camber and is changed by the same angle. It is not possible to adjust king-pin inclination alone, as this is determined initially by the steering knuckle. If king-pin inclination is incorrect although camber is satisfactory, the steering knuckle is deformed and should be replaced with a new part.

**TURNING ANGLES**

If wheel alignment is correct then all four wheels describe circles with a common center when the car takes a curve. Since the rear wheels are fixed the common center must lie somewhere on their extended axis. The figure shows that the inner front wheel must be turned more than the outer if both are to describe circles around the same center. Correct steering geometry is mainly dependent upon steering arm alignment but the tie rods also have a certain effect, especially when suspension movement occurs. This will be seen from the next figure.

**CHECKING AND ADJUSTMENT**

Toe-in must be correctly adjusted before checking of turning angles is commenced. To check turning angles, use two standard-pattern turntables provided with arc graduation. Locate turntables as near wheel turning centers as possible.

Turn steering wheel to the left, until right front-wheel graduated arc reads  $20^{\circ}$ . If turning angles are

correctly set, the other wheel will show  $22 1/2^{\circ} \pm 1 1/2^{\circ}$ .

Carry out a corresponding check, turning steering wheel to right. Incorrect turning angles, as revealed by these tests, are due to deformation of one or both steering arms. Faulty steering arms must not be restraigthened but replaced with new ones.





## DESCRIPTION

The rear axle comprises a rigid transverse tube with swept-back ends, movably attached to the body at three points by means of rubber-bushed bearings; end plates, at the terminations of the tubular axle carry the press-fitted stub axles. Wheel hubs and brake drums are carried in ball bearings on the stub axles. The back plates with associated brake shoes are fixed to the axle end plates. At its center the rear axle is attached to the body by a rubber-bushed bearing bracket 1. Side connections to the body are through two longitudinal side links 9, which are also carried in rubber-cushioned bearings at both body and rear axle.

Inside of the rear axle end plates the lower spring seats are bolted to the stub axle extension. Upper seats for the coil springs are bolted to the body over an insulator. The upper seats are combined with the rubber buffers which limit rear axle and wheel travel upwards. Stop straps are provided to limit rebound travel.

Rear shock absorbers on the Saab 95 are of arm type, bolted to the body and connected to the rear axle by link arms, 10.

Rear shock absorbers on the Saab 96 and the GT 750 are of telescopic type. They have rubber-cushioned connections to body and rear axle respectively.

### DISASSEMBLY OF REAR AXLE

1. Remove rear seat and back cushions.
2. Jack up rear of car and remove wheels.
3. Remove exhaust pipe and rear muffler from floor and wheelhouse.
4. Disconnect brake hose from body.
5. **Unscrew the stop straps rear brackets and remove coil springs (no tool required).**
6. Suspend axle temporarily in stop straps.
7. Disconnect shock absorbers:
  - on Saab 95, disconnect from rear axle;
  - on Saab 96, disconnect at upper connection.
8. Disconnect brake cable clamps from axle and cable connections to brake levers.
9. Disconnect axle center bearing bracket from body by unscrewing its four bolts.
10. Disconnect side link front bearing brackets from body. Nuts are accessible from inside of car, being located under rear seat cushion.
11. Unscrew rear stop-strap brackets again and remove rear axle assy. from car.

### REASSEMBLY OF REAR AXLE

Clean all parts thoroughly. After a careful check, replace any worn or damaged parts. Reassemble in reverse order to disassembly. Note that rubber-bushed bearings must be refitted in such a way that no stresses are set up when car is lowered onto wheels; the bracket bolts to body and axle should not be tightened until the car has been lowered to floor, and is unloaded.

Ends of stop straps should project approx. 5/8 in. (15 mm) beyond the brackets.

## REAR SPRINGS

### REPLACEMENT OF REAR COIL SPRINGS AND/OR RUBBER BUMPERS

#### DISASSEMBLY

1. Jack up one side of car, applying jack under rear end of sill.
2. Remove rear wheel.
3. Unscrew stop strap rear brackets and allow axle to drop down, permitting removal of coil spring without any tools.
4. If rubber bumper requires replacement, unscrew this by gripping the steel washer at thick end of bumper with a suitable pair of pliers.
5. Check also whether stop strap requires replacement.

#### REASSEMBLY

1. If rubber bumper has been removed, screw new bumper in place. Remember lockwasher between bumper and bumper seat.
2. Replace spring.
  - Fit new spring with unmachined end downwards, turning spring until correctly located in lower spring seat.
3. If stop strap has been removed, fix a new strap at front bracket. Note that end of strap should project 5/8 in. (15 mm) beyond bracket.
4. Replace wheel and lower car to floor.
5. Reconnect stop strap at rear bracket, once again noting that end of strap should project beyond bracket.



## SHOCK ABSORBERS

Faulty shock absorbers must be replaced. This is very important since shock absorbers have a great effect upon the steering and road behaviour of the car.

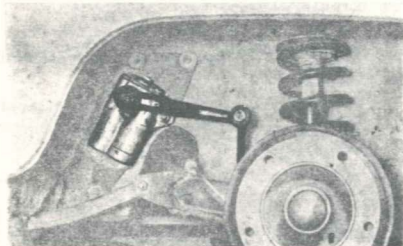

Rear shock absorber, Saab 95

### SAAB 95

#### DISASSEMBLY

1. Jack up car and remove wheel.
2. Disconnect shock absorber from body and rear axle.
3. Remove shock absorbers, placing washers and rubber parts in a safe place.

#### REASSEMBLY

Replace faulty rubber parts with new ones. Use only genuine spare parts. Refit shock absorber with connecting parts, greasing pin threads and tightening nuts hard up. Shock absorber connecting parts are seen in the figure.

#### TOPPING UP SHOCK ABSORBERS

Rear shock absorbers on the Saab 95 must be inspected every 7,500 miles (12,000 km) and topped up if necessary with suitable shock absorber fluid of good quality.

### SAAB 96 AND GT 750

#### DISASSEMBLY

1. Jack up car and remove wheel.
2. Disconnect upper and lower shock absorber connections.
3. Remove shock absorber, placing washers and rubber parts in a safe place.

#### REASSEMBLY

Replace any faulty rubber parts with new ones. Use only genuine spare parts as otherwise noise may be encountered. Bleed shock absorbers

before refitting by pumping several full strokes with the shock absorber held in the same position as when fitted in car. Refit the shock absorber immediately afterwards as, if it is laid down, air may re-enter its valve system. Assemble all rubber bushings and washers in correct order when refitting — see fig. Take care to locate rubber bushings correctly at upper connection; flange of bushing should be pressed into hole in body so that shock absorber is centered in the hole. Failure to observe this may cause noise trouble. Grease pin threads before fitting nuts. Tighten nuts hard up.

## SIDE LINKS AND BEARINGS

### REPLACEMENT OF SIDE LINK RUBBER BUSHINGS

1. Remove rear axle from car.
2. Disconnect side links from rear axle.
3. Disconnect body bearing brackets from side links.
4. Bushings are best removed by gently heating link bearing sleeves with a burner flame or similar, after which bushings may be pressed out with driver, tool No. 784076, which is also used for fitting the new bushing.
5. Refit body bearing brackets to side links. Note that when tightened up, angle between bracket base and side link should be  $4^{\circ}$ .
6. Refit side links to rear axle but do not tighten nuts yet. These nuts must never be tightened until car is resting on wheels again. Insert bolts from outside towards axle center.
7. Replace rear axle on car.
8. Lower car to floor and tighten nuts on side link rear bearing brackets. Check elastic stop nuts for fatigue, replacing poor holders with new nuts.

## CENTER BEARING

### REPLACEMENT OF CENTER BEARING RUBBER BUSHING

When replacement of the center bearing bushing is required it is best to disassemble entire rear axle. It is possible, however, to replace the bushing with out removing the axle from car.

# 10 REAR AXLE AND SUSPENSION



## REPLACING BUSHING WITHOUT REMOVING REAR AXLE

1. Jack up rear of car.
2. Remove rear muffler and exhaust pipe from wheelhouse and floor, respectively.
3. Back off nut on center bearing pivot pin and remove pin.
4. Pull rear axle downwards and insert steel bars across tunnel recess, between rear axle and floor, on each side of bearing.
5. Fit tool No. 784073 and extract rubber bushing.
6. Insert new bushing with same tool. Locate bushing centrally in bearing.
7. Refit bearing bracket to floor but do not tighten nut. This must not be tightened until car is resting on wheels.
8. Refit rear muffler and exhaust pipe to wheelhouse and floor, resp.
9. Lower car to floor.
10. Tighten rear axle center bearing pin.

## REPLACING BUSHING ON DISASSEMBLED REAR AXLE

Carry out the job with the same tools and in the same manner as described above.

## WHEEL BEARINGS

### GENERAL

Wheel bearings may become worn after a considerable mileage, especially if the lubrication has been unsatisfactory; free play will then arise. This seriously affects the steering characteristics of the car, and the bearings must be replaced. To check whether excessive play exists, jack up the car and grip the wheel firmly at top and bottom. Attempt to wobble the wheel. Any movement will be immediately detected. If such play exists and exceeds 0.08 in. (2 mm), measured at the rim, the bearing must be replaced. Note when disassembling and reassembling wheel bearings that, in addition to the tools mentioned, a press is also required. The ball bearings must on no account be subjected to blows as they may easily be damaged thereby.

## REPLACING BALL BEARINGS IN REAR WHEEL HUB, SAAB 95

### DISASSEMBLY

Before starting work check that car is properly cleaned under fenders. All dirt that might enter the bearings must be removed.

1. Jack up car and remove wheel.
2. Remove dust cap, with a screwdriver.
3. Remove cotter pin, castle nut and washer.
4. Check that hand brake is fully released.

5. Remove brake drum with puller 784002.
6. Remove shaft seal and lock ring.
7. Press out both bearings, in the direction from outside of brake drum.

### REASSEMBLY

Clean all parts thoroughly and replace any worn or damaged parts. A new shaft seal must be fitted.

1. Pack ball bearings with bearing grease.
- Lubrication.**
2. Press in the small bearing 1/2 in. (12 mm) with driver, tool No. 784033.
  3. Turn drum over and fill hub with grease sufficient to occupy about half the space between bearings.

### NOTE

If too much grease is used it may be pressed out and spoil the brake linings.

4. Insert spacer and press in big bearing, using driver, tool No. 784032.
5. Fit lock ring.

### NOTE

Lock ring is of special type and must always be fitted

6. Fit a new shaft seal.
7. Check that shaft seal bearing surface is undamaged. If damaged, it must be corrected and polished with very fine emery cloth. Lubricate bearing surface with ball bearing grease.
8. Replace brake drum and torque castle nut, to 65—72 ft-lb. (9—10 kpm). Secure with cotter pin.
9. Fit dust cap, using tool No. 784036.
10. Replace wheel and lower car to floor.

## REPLACING BALL BEARINGS IN REAR WHEEL HUB, SAAB 96 AND GT 750

### DISASSEMBLY

Before starting work check that car is properly cleaned under fenders. All dirt that might enter the bearings must be removed.

1. Jack up car and remove wheel.
2. Remove dust cap with a screwdriver.
3. Remove cotter pin, castle nut and washer.
4. Check that hand brake is fully released.
5. Remove brake drum with puller 784002.
6. Insert a suitable driver in the tapered spacer, from inside, and press out small bearing.
7. Press out the big bearing in the other direction, removing lock ring if necessary.





**REASSEMBLY**

Clean all parts thoroughly and replace any worn or damaged parts. Be sure to replace shaft seal if at all worn or damaged. Note that the bearing and spacer included in a bearing set must be fitted together if a correct fit is to be secured. Insert ball bearings with markings facing away from each other, so that these are visible after assembly. Bearings without markings should be fitted with the ball-insert facing inwards.

1. Fit lock ring in hub.
2. Press in small bearing with driver, tool No. 784033;
3. Insert spacer and fill with grease sufficient to occupy about half the space between bearings.

**NOTE:**

If too much grease is used it may be pressed out and spoil the brake linings.

**IMPORTANT**

Always fit the parts of a bearing set as a complete set.

4. Press in big bearing with driver, tool No. 784032. See fig.
5. Fit shaft seal in hub.
6. Check that shaft seal bearing surface is undamaged. If damaged, it must be corrected and polished with fine emery cloth. Lubricate bearing surface with ball bearing grease.
7. Replace brake drum and torque castle nut, to 65—72 ft.-lb. (9—10 kpm) torque. Secure with cotter pin.
8. Fit dust cap using tool No. 784036.
9. Replace wheel and lower car to floor.

**REAR WHEEL ALIGNMENT**

Camber .....	$0 \pm 1^\circ$
Toe-in(out)	
both wheels together .....	$0 \pm 1^\circ$
or measured rim-to-rim .....	$0 \pm 7 \text{ mm (0.28 in.)}$
Toe-in for each wheel must not exceed: .....	$0 \pm 3/4^\circ$
Maximum difference in wheelbase, left and right (front wheels pointing straight forward): .....	$0.6 \text{ in (15 mm)}$

**REAR WHEEL ALIGNMENT**

**CHECKING AND ADJUSTMENT OF REAR AXLE**

If the rear axle has been subjected to abnormal stresses, for instance in connection with a collision or similar accident, it must be carefully checked for signs of fracture or deformation. If slightly deformed, it may be straightened, preferably cold. After straightening and rechecking allow the axle to rest about eight hours and then carry out a further check. Stub axles should also be carefully checked and, if deformed, they must be replaced. To remove the stub axles, press them inwards and collect the spacer ring outside the end plate.

When inspecting the rear axle, pay special attention to the surface of the inner shoulder on the stub axles. The face of the shaft seal bears against this surface, which must be absolutely intact. If scratches or any other defects are detected, restore its condition and polish with very fine emery cloth.

It is not normally necessary to adjust rear wheel alignment. However, if the rear axle has been subjected to such abnormal stresses that faulty alignment is suspected, then the angles should be checked. They should be as follows:

If the difference in wheelbase between the two sides exceeds 0.2 in. (5 mm), the wheel alignment is to be checked.

If the wheel alignment corresponds with the above, a wheelbase difference of maximum 0.6 in. (15 mm) is allowed between left and right side.

**NOTE**

Wheel alignment may be incorrect without affecting the wheelbase.

**NOTE**

For checking the toe-in(out) special gage tools intended for wheel aligning are required.



**GENERAL**

Two patterns of steering gear are fitted, for right and left-hand steering. The two patterns are similar in principle, however. The gear is of rack-and-pinion type and the main components are a spiral pinion meshed with skew teeth on a rack. The steering gear is enclosed by a light-alloy housing, in which the toothed rack is borne. Movements of the steering wheel, splined onto the steering column stub end, are transmitted by the column to the pinion. The pinion, imparts a transverse motion, back and forth, to the rack, which in turn actuates the tie rods, 8, attached by ball joints, 2, to the rack ends. The tie rods transmit the movement to the steering arms, which are united with the steering knuckles, 4, and connected to the tie rods by the tie rod ends, 3.

The Saab is fitted with column gear shift; the shift shaft is connected through universal joints to the transmission case operating rod. The universal joints connect each end of a short intermediate shaft to shift shaft and operating rod, respectively. Gear-shift mechanism may be of 3 or 4-speed type.

Two alternative methods for removal and installation of the steering gear are described, due to a design modification effective from chassis No. 108201. The first method can be used for all vehicles, but Alt. II can be used only on No. 108201 and subsequent chassis numbers. Use Alt. II on right-hand drive cars.

**ALT. I****REMOVAL**

1. Remove hood.
2. Disconnect one of battery leads.
3. Jack up front of car.
4. Remove front wheels.
5. Disconnect tie rods from steering arms.
6. Back off locknut and remove tie-rod end and locknut from left-hand tie rod. Use tool No 784004.
7. Remove warm-air duct from air cleaner and cardboard sheet from between radiator and dash panel.
8. Remove lower taper pin from column gear-shift shaft and release universal joint from transmission case operating rod. Use tool 784083.
9. Release freewheel control from transmission.
10. Back off clamp screw retaining brake-fluid reservoir and press reservoir slightly downwards, or (for cars of later type) release brake hose from clips on steering gear housing.

11. Release throttle spring and attach it in some suitable way, so that the throttle control moves back as far as possible.
12. Back off retaining screws for flasher switch and allow switch to hang free. Collect any loose shims.
13. Turn steering wheel to full left lock, remove clamp screw in column yoke, and lift column yoke clear of stub shaft by means of steering wheel.
14. Turn back floor mat and remove left toeboard.
15. Release clamp retaining dash-panel lining (located under toeboard). Simplest way to release the clamp is by compressing with pliers from the engine compartment.
16. Back off and remove four retaining bolts for steering gear. Collect possible washers between gear and dash panel.
17. Insert a block of wood, for example, between dash panel and its lining to hold the latter about 3 in. (8 cm.) from the dash panel around the stub shaft.
18. Lift left side of steering gear, forward over gear-shift operating rod, until steering-gear stub shaft is clear of dash panel. Be careful not to damage panel lining.
19. Back steering gear through right-hand wheelhouse on that side, then lift steering gear forward and up between left-hand wheelhouse and engine.

**INSTALLATION**

1. Remove tie-rod end and locknut from left-hand tie rod.
2. Move steering rack to bring left-hand tie rod to its inner position.
3. Insert steering gear between left wheelhouse and engine in reverse manner to removal, above.
4. Push steering gear against cowl plate in reverse order to removal and put the rubber seal on the stub shaft to prevent damage.
5. Pass stub shaft through cowl plate and lining. Fit the rubber seal in the hole on cowl plate.
6. Remove block of wood between cowl plate and lining and refit retaining clip.
7. Fit the four retaining bolts in steering gear.
8. Check that the speedometer cable is not jammed between steering gear and cowl plate before tightening up.



9. Refit locknut and left-hand tie-rod end.
10. Reconnect tie-rod ends to steering arms, tighten nuts and secure with cotter pins.
11. Refit wheels and lower car to floor.
12. Refit freewheel control and gear-shift shaft universal joint.
13. Push brake-fluid reservoir upwards and retighten clamp, or refit hose in clips.
14. Refit throttle control spring.
15. Refit cardboard sheet between radiator and dash panel and reconnect preheater duct.
16. Refit hood.
17. Check toe-in and tighten locknuts at tie-rod ends.
18. Refit toeboard and replace rubber mat.
19. Align front wheels straight ahead and reconnect steering column.
20. Check steering-wheel position and refit clamp screw in yoke on column.
21. Grease tie-rod ends, if necessary.
22. Reconnect flasher and check switch clearance of return yoke.
23. Reconnect battery cable.

## ALT. II

### REMOVAL

1. Remove hood.
2. Back off clamp screw on steering-column yoke; screw is accessible between yoke and dash panel.
3. Disconnect speedometer cable from transmission case and remove cardboard sheet from behind radiator.
4. Back off and remove locknut, and adjustment screw for rack transverse clearance with spring and plug.
5. Back off bolts and remove cover, shims and washer at end of pinion.
6. Extract pinion through engine compartment and collect washer. Plug opening in steering-gear housing with a clean rag, to prevent entry of dust.
7. Jack up front of car, remove both wheels and disconnect tie-rods from steering arms. Use tool No. 784004
8. Back off and remove four bolts retaining steering gear to dash panel and extract steering gear through aperture in left-hand wheelhouse. See fig. Collect possible washers between gear and dash panel.

During the above operation cleanliness is of the utmost importance, otherwise dirt may enter the steering gear and damage bearings and ball joints.

### INSTALLATION

1. After correct readjustment, refit steering gear. The following parts must be removed: locknut, adjustment screw for transverse clearance, with spring and plug, also cover, shims and washer for pinion side clearance, and the pinion itself. During installation protect the steering gear from dirt by plugging the pinion opening with a clean, lint-free rag.
  2. Pass steering gear through opening in left-hand wheelhouse, and bolt to dash panel with four retaining bolts. Remember to fit spring washers, and spacer washers if required.
  3. Fit washer on pinion stub shaft and insert pinion in steering-gear housing. Fit cover with requisite shims.
  4. Locate spring in adjustment screw and fit plug on spring. Fit whole assembly in steering-gear housing. Tighten locknut after adjustment.
  5. Connect tie-rod ends to steering arms, fit washers and tighten nuts with a torque of 25—36 ft.-lb. (3.5—5 kgm.). Secure with new cotter pins.
  6. Connect steering column to pinion stub shaft, push down column and tighten clamp screw. Steering-wheel spokes should be horizontal when the front wheels are aligned straight ahead.
  7. Refit wheels and lower car to floor.
  8. Adjust toe-in
- Remember to tighten tie-rod end locknuts after adjustment.
9. Insert cardboard sheet behind radiator and refit hood.

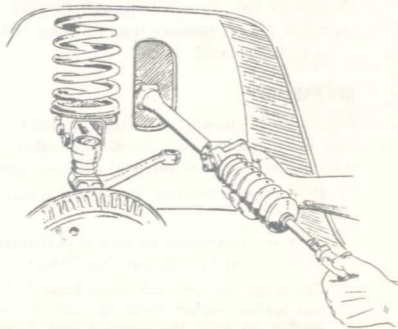

Dismounting steering gear. Alt. II.



## STEERING GEAR

### GENERAL

The steering gear is carefully adjusted at the factory and should not be disassembled unless necessary. Adequate lubrication is essential for smooth functioning but do not fill the steering-gear housing entirely with grease. When long periods of extreme cold are anticipated, use cold-resistant grease for the steering gear.

Undue noise from the steering gear indicates the need for readjustment, see below. Replace all worn or damaged parts.

The illustration is of the steering gear for l.h.-steered car, but the steering gear for r.h.-steered models is similar in principal and these remarks apply equally in both cases.

### DISASSEMBLY

1. Release locknuts, \_\_\_\_\_ and remove tie-rod ends.
2. Release clamps and remove rubber bellows.
3. Turn up tabs on lockwashers.
4. If gear pinion has been removed previously, insert it temporarily.
5. Release both tie-rod ball joints with tool No. 784071.
6. Remove pinion. In steering gears as described under Alt. I it will be necessary to first disconnect right ball joint and pull rack sufficiently to the left to permit removal of pinion.
7. Disassemble ball joints and collect shims, inner ball seats and locating washers.
8. Extract rack from steering-gear housing.
9. Drive pinion bushing from housing, if bushing is to be replaced.

### REASSEMBLY

Observe strict cleanliness during reassembly. Smear rack and pinion, bearing journals and other contact surfaces liberally with universal or chassis grease.

1. Drive pinion bushing into steering-gear housing.
2. Fit a new lockwasher on rack at pinion end and screw on nut 15 with tool No. 784071.
3. Fit shims on nut and place inner ball seat and spring washer inside the nut. Fit spring washer so that the concave side faces the ball seat.
4. Pass rack and pinion into housing.

### NOTE

With gears as per Alt. I, the rack must be located in a specific position.

With gears as per Alt. II, pinion spacer must be fitted before passing rack into housing.

5. Fit outer ball seat on tie rod and tighten seat on nut by means of tool 784071.
6. Check shimming of ball joint. If unsatisfactory, release ball seat and change shim pack as described under ADJUSTMENT.
7. When ball joint is assembled, secure locknut, see fig. on following page.
8. Fit the right ball joint and adjust it similarly. Note that for alt. I the pinion has to be inserted before the right ball joint is fitted.
9. First adjust the end float of the pinion and then the radial play of the rack, see ADJUSTMENT instructions on following page.
10. Pass rubber bellows over tie rods and clamp to housing and tie rods, respectively. Do not tighten excessively but leave tie rods free to rotate.
11. Fit locknuts and tie-rod ends to tie rods.

### INSPECTION OF STEERING GEAR

After considerable mileage, and especially if lubrication is poor, the rack may wear unevenly. If there is visible wear of the rack shaft, replace the part. Check also the rack journal at the steering-gear housing, preferably by comparison with a new rack. Excessive wear may be corrected by replacement of the bushing pressed in the housing.

Inspect the teeth of both rack and pinion for wear. The teeth will not be uniformly worn, the ones which are in mesh when steering straight ahead being worst affected. However, if lubrication is good, even the worst affected teeth will be worn very little.

If the rack teeth are abnormally worn the action of the steering gear will be considerably affected and adjustment made more difficult. The rack should therefore be replaced.

The pinion, on the other hand, if wear is moderate, may be rotated a half-turn so that the worn teeth are located farthest from the rack when the car is travelling straight ahead. But the most satisfactory solution is to replace the pinion also. Check outer and inner tie-rod ball joints. The outer ball joints are self-adjusting for moderate amounts of wear; if free play has arisen, the entire ball joint must be replaced. The components of inner ball joints are subject to very little wear, providing lubrication is adequate. If noticeable wear has occurred, replace affected parts.





## ADJUSTMENT

The following adjustments may be necessary:

1. Pinion end float.
2. Rack radial clearance.
3. Tie-rod inner ball joints.

The steering gear must be removed from the car for the third adjustment, but the other adjustments may be done while the steering gear remains in place. Adjustment of the inner ball joints is very seldom required in practice, since the wear here is very slight and the ball joints are self-adjusting to a certain extent.

## ADJUSTMENT OF PINION END FLOAT

If noise, play or other trouble occurs in the steering mechanism, the pinion should be examined for excessive axial or radial clearance.

Excessive clearance may be the result of wear or of the replacement of some part. Normally, wear is very slight and adjustment for this reason is seldom required, providing lubrication is adequate.

Axial clearance of the pinion (i.e. the column) can be corrected by shimming. There should be a clearance of .004—.008 in. (0.1—0.2 mm) between the pinion and the housing cover, and this can be secured by selecting a suitable combination of shims, which are available in .04 in. and .12 in. (0.1 and 0.3 mm) thickness.

1. Adjustment can be carried out without removing steering gear from car. Jack up car to lift both front wheels off the floor.
2. After backing off locknut, back off rack transverse-clearance adjustment screw until spring is completely unextended.
3. Back off both cover bolts at pinion end, see fig.
4. Remove cover, together with shims located under.
5. Modify shim pack to required thickness.
6. Check that washer is in place, and smear a spot of universal or chassis grease round pinion stub shaft. Refit cover with shims, fit bolts and lockwashers, and tighten.
7. Check free movement of pinion after adjustment. If pinion is stiff, shim pack is too thin and re-adjustment is necessary.
8. Adjust rack radial clearance as described in following paragraph.

## ADJUSTMENT OF RACK CLEARANCE

After adjustment of pinion axial clearance, adjust rack radial clearance, i.e. the pinion back lash. This can also be carried out without removing the steering gear from the car.

1. Back off locknut.
2. Adjust screw until rack moves only stiffly.
3. Back off screw 1/8-turn.
4. Tighten locknut.
5. Swing wheel from full lock to full lock and check that rack moves freely at all positions.

## ADJUSTMENT OF TIE-ROD INNER BALL JOINTS

The tie rods, are identical on right and left sides. The rack end of each rod is formed as a double ball while the other end is threaded for connection to the tie-rod end.

1. The steering gear must be removed from the car before the inner ball joint can be adjusted.
2. Release clamps and remove rubber bellows.
3. Pull rack first to one side. Turn up tab on lockwasher and release outer ball seat and nut with tool No. 784071.
4. Fit a new lockwasher and tighten nut with tool No. 784071.
5. Fit a suitable combination of shims on the nut and place inner ball seat and spring washer inside the nut. Fit spring washer so that the concave side faces the ball seat.
6. Fit outer ball seat on tie rod and tighten ball seat with tool No. 784071.
7. Check that shimming is correctly adjusted — there should be no play in the ball joint, but, it should move freely in all positions. If the rack and tie rod are held vertical, it should be

possible to set the tie rod, complete with tie-rod end, at any angle without it falling down by its own weight.

8. If adjustment is not satisfactory, remove ball seats again and modify shim pack. Finally, secure with lockwasher.

## WARNING

The tie rod must not be excessively stiff at any position. It should be possible to move it fully in any direction by light manual pressure.

9. Repeat adjustment procedure for other tie rod.
10. Refit rubber bellows and re-install steering gear in car.





### OTHER ADJUSTMENTS

If, after adjustment of the rack and pinion, the steering gear is still stiff at any position it is probably due to stresses introduced when tightening the steering gear bolts. Back off both retaining bolts at the end farthest from the pinion and insert a shim under the housing at the corner where it does not lie flush. On some cars, it will be noted that a washer has already been fitted at the factory.

### REPLACEMENT OF RUBBER BELLOWS

If damaged, the rubber bellows must be immediately replaced; otherwise dirt can enter the steering gear and cause seizing.

1. Jack up front of car and remove appropriate wheel.
2. Remove tie-rod end
3. Release bellows clamps at steering gear and tie rod, and remove bellows.
4. Remove all old grease, fit a new rubber bellows and tighten clamps.
5. Refit tie-rod end and reconnect to steering arm
6. Refit wheel and lower car to floor.
7. Grease steering gear and adjust toe-in scribed in Finally, tighten locknuts.

### TIE-ROD ENDS

#### GENERAL

The outer ball joints, or tie-rod ends, are screwed on the tie rods and secured with locknuts. The total length of the tie-rod assembly can be reduced or increased by backing off the locknut and turning the tie rod by means of a wrench applied to the flat of the rod. This is necessary to adjust toe-in, see Chapter 9.

The tie-rod end is connected to the steering arm by a taper pivot, which fits in a correspondingly tapered hole in the arm, and is secured by a castle nut and cotter pin.

The tie-rod ends cannot be disassembled. Since they are self-adjusting for moderate wear, they seldom require replacement. However damage due to extraneous causes, such as a collision, for example, may necessitate replacement of the complete tie-rod assembly. As a safety measure, damaged tie-rod ends should be replaced as soon as possible after the damage is observed.

### REPLACEMENT OF TIE-ROD ENDS

The tie-rod ends cannot be disassembled and must be replaced as complete units if excessive play arises.

1. Jack up front of car and remove appropriate wheel.
2. Knock out cotter pin, and remove castle nut, and washer, — see fig.
3. Fit puller tool, No. 784004, and release pivot from steering arm. Do not hammer pivot, as this may cause damage both to pivot and other parts.
4. Back off nut retaining tie-rod end on tie rod.
5. Unscrew tie-rod end from tie rod.
6. Screw new tie-rod end in place but do not tighten locknut as yet.
7. Refit pivot to steering arm. Tighten castle nut, using a torque of 25–36 ft.-lb. (3.5–5 kgm.) and fit a new cotter pin.
8. Refit wheel and lower car to floor.
9. Adjust toe-in

#### IMPORTANT

Remember to tighten locknut after adjustment.

### REPLACEMENT OF RUBBER SEAL

A rubber seal is fitted to each tie-rod end. If this is damaged and no longer gives an effective seal, it must be replaced. Proceed as follows:

1. Jack up car and remove appropriate wheel.
2. Remove cotter pin, castle nut and washer from tie-rod end pivot.
3. Using tool No. 784004, disconnect pivot from steering arm. See fig. Do not hammer pivot, as this may damage both pivot and other parts.
4. Remove damaged seal from pivot and fit a new seal.
5. Refit pivot in steering arm, replace washer and castle nut, and tighten with a torque of 25–36 ft.-lb. (3.5–5 kgm.). Secure nut with cotter pin.
6. Refit wheel and lower car to floor.

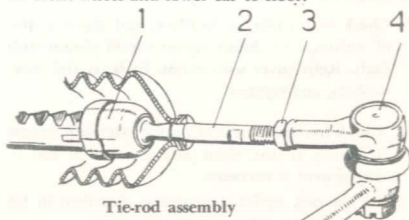

Tie-rod assembly

1. Inner ball joint
2. Tie rod
3. Locknut
4. Tie-rod end



## STEERING WHEEL AND GEAR SHIFT

Saab cars are made for both right and left-hand steering, and with both 3-speed and 4-speed transmissions. The steering mechanism is similar on all models, however, except that wheel fitted to the G.T 750 differs from that fitted to the Saab 95 and 96.

## STEERING WHEEL: HORN BUTTON ASSY.

## DISASSEMBLY

Up to and incl. chassis No. 168000

1. Disconnect horn wire at connector, accessible under instrument panel.
2. Remove horn button with the aid of a thin screwdriver or penknife inserted between button and steering-wheel hub. Pry gently, and button will come free — see fig.
3. Disconnect wire from contact plate.
4. Twist contact plate, to permit removal of both plate and spring.
5. Back off nut; remove locating washer and contact cup.
6. Lift away steering wheel.
7. Washer under steering wheel and return yoke for turn indicator switch can now be removed.

## From chassis No. 168001

1. Disconnect horn wire at connector under instrument panel.
2. Remove central button by prying gently with the aid of a thin penknife or other suitable tool under edge of button — see fig.
3. Disconnect horn wire from contact plate.
4. Unscrew nut and remove spring washer.
5. Remove horn ring.
6. Lift away steering wheel.
7. Return yoke for turn indicator switch can now be removed.

## NOTE

There are two types of return yoke, one with splines and one without, the latter being pressfitted on the column. See figs.

There are also two different arrangements for fixing the directional indicator switch to the column stand: the switch being located either at right angles to the column, or inclined at about 80° to the column. In the latter case, the switch must be removed before the return yoke can be removed, but in the former case this is not necessary.

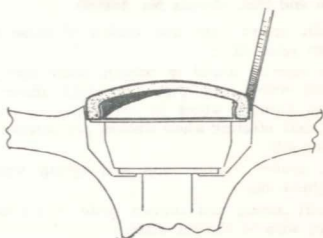

Removal of horn button, up to and incl. chassis No. 168000

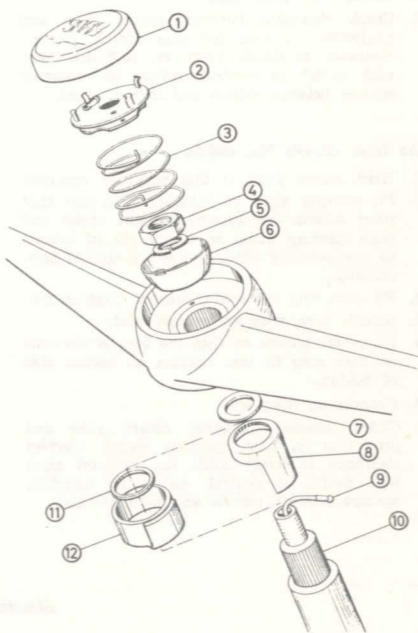

Steering wheel and horn button assembly, up to and incl. chassis No. 168000

- |                     |                                   |
|---------------------|-----------------------------------|
| 1. Horn button      | 8. Return yoke, splined type      |
| 2. Contact plate    | 9. Horn wire                      |
| 3. Spring           | 10. Steering column               |
| 4. Nut              | 11. Washer (if fitted)            |
| 5. Locating washer  | 12. Return yoke, non-splined type |
| 6. Contact cup      |                                   |
| 7. Washer under cup |                                   |



## REASSEMBLY

## Up to and incl. chassis No. 168000

1. Refit return yoke and washer if these have been removed.
2. Fit steering wheel on column. Make sure that front wheels are aligned straight ahead and push steering wheel on centre pin of column so that steering-wheel spokes are aligned horizontally.
3. Fit spacer, contact cup and spring washer. Tighten nut.
4. Insert spring and contact plate, and connect horn wire to contact plate.
5. Fit horn button so that the four projections on contact plate fit into notches on bottom side of button.
6. Connect up horn wire.
7. Check clearance between return yoke and projection on turn indicator switch. Correct clearance is 0.008—0.024 in. (0.2—0.6 mm) with switch at neutral. Adjust by inserting spacers between switch and column stand.

## As from chassis No. 168001

1. Refit return yoke, if this has been removed.
2. Fit steering wheel on column. Make sure that front wheels are aligned straight ahead and push steering wheel on centre pin of column so that steering-wheel spokes are aligned horizontally.
3. Fit horn ring and spring washer. Tighten nut.
4. Attach horn wire to contact plate.
5. Fit centre button so that the four projections on horn ring fit into notches on bottom side of button.
6. Connect up horn wire.
7. Check clearance between return yoke and projection on turn indicator switch. Correct clearance is 0.008—0.024 in. (0.2—0.6 mm) with switch at neutral. Adjust by inserting spacers between switch and column stand.



S 248

## Removal of horn button, as from chassis No. 168001

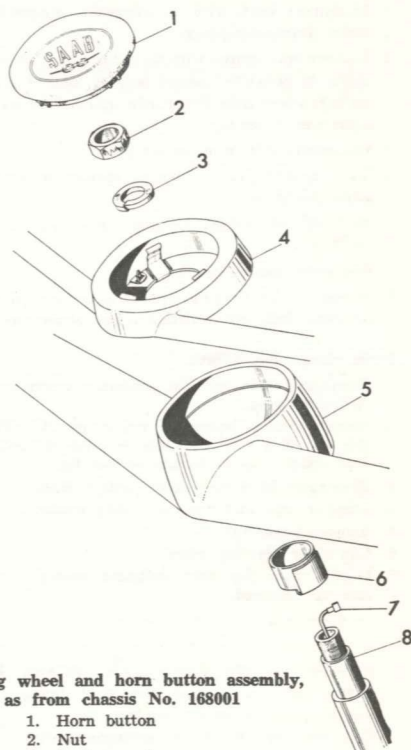

S 249

## Steering wheel and horn button assembly, as from chassis No. 168001

1. Horn button
2. Nut
3. Spring washer
4. Horn ring
5. Steering wheel
6. Return yoke
7. Horn wire
8. Steering column



## STEERING COLUMN AND BEARINGS

### DISASSEMBLY

Disassembly of the column involves disassembly of the shift-gear mechanism, since this is mounted in the same stand.

1. Disassemble steering wheels and horn-button assy., as described.
2. Loosen and remove clamp screw at column connection to steering gear pinion.
3. Remove cardboard sheet from behind radiator.
4. Unscrew nut from upper end of gear-shift shaft universal joint and drive out taper pin. Use tool 784083.
5. Undo the two screws for steering-column stand. If gear lever lock is fitted, drive out the locking pins in screws first. The stand and steering column, together with gear-shift shaft and lever, are now loose and can be removed from the car.
6. Draw column out of its bearing.
7. Remove the two rubber bearing bushings.

### REASSEMBLY

1. Refit rubber bushings -

#### NOTE

The upper rubber bushing is thinner than the lower rubber bushing. Furthermore, the bushings are tapered and must therefore be fitted with the arrow marked on the locating shoulder pointing towards the steering wheel.

2. Pass column into bearing.
3. Refit assembly in car. Adjust position as described under "Checking and Adjustment" and secure steering-column stand by tightening the two screws. If gear-lever lock is fitted, drive the locking pins home.
4. Fit locating spring and reconnect shift shaft to universal joint with taper pin.
5. Refit cardboard sheet behind radiator.
6. Reconnect steering-column joint to steering-gear pinion and tighten clamp screw.
7. Refit steering wheel and horn-button assy. as described above.

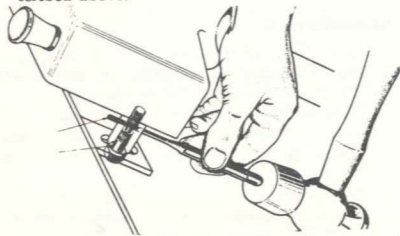

Removing locking pins on steering-column stand in a car with gear lever lock.

## GEAR-SHIFT MECHANISM LEFT-HAND DRIVE, 3-SPEED

### DISASSEMBLY

1. Disassemble steering-column stand with column and gear-shift mechanism as described above.
2. Loosen nut on gear-shift lever and remove bolt — see fig. Lever can now be removed.
3. Pull gear-shift shaft out stand. If gear-lever lock is fitted, first loosen three screws in twist stop through holes in steering-column stand and pull twist stop off.
4. Remove fork nut, remove washer and spring.
5. Remove felt bushing from stand.

### REASSEMBLY

1. Insert new felt bushing in stand. Soak bushing thoroughly in paraffin or tallow, and remove all excess fat before inserting.
2. Place spring and washer on fork nut.
3. Screw in fork nut far enough to leave about 0.04 in. (1 mm) clearance between fork flange and edge of stand.
4. Insert gear-shift shaft in stand and refit gear-shift lever, making sure that spring is correctly located.
5. Insert bolt through gear-shift lever and oval hole in gear-shift shaft. Tighten nut to eliminate all play but without impairing free movement of lever.
6. If gear-lever lock is fitted: slide twist stop onto gear-shift shaft with marking turned upwards to face steering wheel. Turn ignition key to locked position so that lock plunger slides into recess in twist stop.
7. Reassemble column stand together with steering column and gear-shift mechanism.
8. Adjust twist stop — see "Gear-lever lock".

## GEAR-SHIFT MECHANISM LEFT-HAND DRIVE, 4-SPEED

### DISASSEMBLY

1. Disassemble steering-column stand with column and gear-shift mechanism as described above.
2. Loosen nut below gear-shift lever housing and pull gear-shift shaft out of stand. Note the stop screw. If gear-lever lock is fitted, first loosen three screws in twist stop through holes in stand and pull twist stop off.
3. Apply a screwdriver blade to one flank of stop block in square hole in shift-lever housing, at the same time gripping lever knob and pressing lever while turning through 1/4 turn. Screw knob off lever and push lever out of housing. Stop block, spacer, spring and plastic ball will now be released.
4. Remove washers, bushing, spring and felt ring from gear-shift shaft.
5. Remove nut from gear-shift lever housing after having extracted locking.



**REASSEMBLY**

Renew all worn or damaged parts before reassembling gear-shift mechanism.

1. Refit felt ring, washers, bushing and spring on gear-shift shaft
2. Refit nut and lockring to gear-shift lever housing.
3. Put plastic ball, spring, stop block and spacer on gear-shift lever, and refit lever in housing.
4. Slide gear-shift lever housing onto shaft and pass lever through hole in shaft, taking pains to do so at correct angle, since it must pass diagonally through gear-shift shaft. Press simultaneously on stop block and outer end of gear-shift lever, twisting lever until pin through it enters its groove in spacer.
5. Replace the knob.
6. Fit the rubber ball between gear-shift shaft and gear-shift lever housing, positioning it on same side as gear-shift lever.
7. Slide gear-shift shaft into bearing and tighten nut. If gear-lever lock is fitted, slide twist stop onto gear-shift shaft with marking turned upwards to face steering wheel. Turn ignition key to locked position so that lock plunger slides into recess in twist stop.
8. Reassemble steering-column stand together with steering column and gear-shift mechanism. Remember to fit washer and return spring on gear-shift shaft. If gear-lever lock is fitted, drive locking pins home.
9. Adjust position of steering-column stand as described under "Checking and Adjustment".

**GEAR-SHIFT MECHANISM RIGHT-HAND DRIVE, 3-SPEED****DISASSEMBLY**

1. Disassemble steering-column stand with column and gear-shift mechanism as described above.
2. Loosen nut below gear-shift lever housing and pull gear-shift shaft out of stand. Note the stop screw. If gear-lever lock is fitted, first loosen three screws in twist stop through holes in steering-column stand and pull twist stop off — see "Gear-lever lock".
3. Apply a screwdriver blade to one flank of stop block in square hole in gear-shift lever housing, at the same time gripping lever knob and pressing lever while turning through 1/4 turn. Screw knob off lever and push lever out of housing. Stop block, spacer, spring and plastic ball will now be released.
4. Remove washers, bushing, spring and felt ring from gear-shift shaft.
5. Remove nut from gear-shift lever housing after having extracted lockring.

**REASSEMBLY**

Renew all worn or damaged parts before reassembling gear-shift mechanism.

1. Refit felt ring, washers, bushing and spring on gear-shift shaft
2. Refit nut and lockring to gear-shift lever housing.
3. Put plastic ball, spring, stop block and spacer on gear-shift lever, and refit lever in housing.
4. Slide gear-shift lever housing onto shaft and pass lever through hole in shaft, taking pains to do so at correct angle, since it must pass diagonally through gear-shift shaft. Press simultaneously on stop block and outer end of gear-shift lever, twisting lever until pin through it enters its groove in spacer.
5. Replace the knob.
6. Fit the rubber ball between gear-shift shaft and gear-shift lever housing, positioning it on same side as gear-shift lever.
7. Slide gear-shift shaft into stand and tighten nut. If gear-lever lock is fitted, slide twist stop onto gear-shift shaft with marking turned upwards facing steering wheel. Turn ignition key to locked position so that lock plunger slides into recess in twist stop.
8. Refit steering-column stand together with steering column and gear-shift mechanism. Remember to fit washer and return spring on gear-shift shaft.

**GEAR-SHIFT MECHANISM RIGHT-HAND DRIVE, 4-SPEED****DISASSEMBLY**

1. Disassemble steering-column stand with column and gear-shift mechanism as described above.
2. Loosen nut below gear-shift lever housing and pull gear-shift shaft out of stand. Note the stop screw. If gear-lever lock is fitted, first loosen three screws in twist stop through holes in steering-column stand and pull twist stop off.
3. Remove pin retaining yoke sleeve.
4. Pull gear-shift shaft out of stand.
5. Remove fork nut and remove washer and spring.
6. Remove felt bushing from stand.
7. Remove spring stop with spring, plastic washer and metal washer from steering-column stand.

**REASSEMBLY**

1. Insert new felt bushing in stand. Soak bushing thoroughly in paraffin or tallow, and remove all excess fat before inserting.
2. Place spring and washer on fork nut.
3. Screw in fork nut far enough to leave about 0.04 in. (1 mm) clearance between fork flange and edge of stand.
4. Insert gear-shift shaft in stand and refit gear-shift lever, making sure that spring is correctly located.



5. Insert bolt through gear-shift lever and oval hole in gear-shift shaft. Tighten nut to eliminate all play but without impairing free movement of lever.
6. Place catch spring plastic washer, metal washer and spring stop in steering-wheel column stand. The plastic washer should be nearest the spring, and collar should center metal washer.
7. If gear-lever lock is fitted: slide twist stop onto gear-shift shaft with marking towards steering wheel. Turn ignition key to locked position so that lock plunger slides into recess in twist stop.
8. Reassemble steering-column stand together with steering column and gear-shift mechanism.

### CHECKING AND ADJUSTMENT OF GEAR-SHIFT MECHANISM

#### DISASSEMBLY AND REASSEMBLY OF UNIVERSAL JOINT

The universal joint between the shift shaft and the operating rod on the transmission case may be greased without disassembly, if the rubber dust excluders are turned back.

1. Remove cardboard sheet from behind radiator.
2. Back off locknut and drive out taper pin, Use tool No. 784083.
3. Release universal joint from shift shaft, collecting gear-shift lever locating spring, if placed on shaft.
4. Back off locknut at other end and drive out taper pin, using same tool.
5. Pull joint free from shift operating rod. Check universal joint for excessive play or stiffness. If new dust excluders are to be fitted, remove old grease and repack joints with fresh grease, before fitting new excluders.
6. Refit joint to operating rod and drive in taper pin, checking that tapered holes in joint and operating rod are aligned.
7. If spring has been removed from shift shaft, refit it. Press joint on shift shaft and drive in taper pin.
8. Fit locknuts to taper pins.
9. Refit cardboard sheet behind radiator.

#### ADJUSTMENT OF STEERING COLUMN STAND

The vertical location of the column stand determines gearshift positions, and must always be checked.

Check gear-shift lever play in plane of shift-shaft axis as follows:

Shift lever to top gear and move gear shift shaft firmly, but not roughly, in both longitudinal directions. The lever knob should move by the amounts indicated in the table below.

### ELIMINATION OF RATTLE FROM GEAR-SHIFT MECHANISM

In order to eliminate rattle in the gear-shift lever, two support springs over and above the original spring are mounted in the gear-shift lever housing of 3-speed, left-hand drive cars as from chassis No. 198368 and of 4-speed, right-hand drive cars as from chassis No. 198728. Rattle in cars with lower chassis numbers than those mentioned above can be eliminated by fitting these springs —

In the case of older 4-speed, left hand drive and 3-speed, right-hand drive cars in which a rubber ball is not provided, a ball should be fitted between the gear-shift shaft and the gear-shift lever housing, on the same side as the gear-shift lever.

Rattle may occur on account of excessive clearance between gear-shift lever housing and nut. Provision of a shim between nut and upper fiber washer will eliminate this.

### GEAR-LEVER LOCK

#### GENERAL

As from the 1964 model, the cars are equipped with a combined ignition and gear-lever lock. The gear-shift lever is locked when the reverse gear is engaged and the key is removed. The gear-lever and ignition lock has the following positions:

- L. *Locked.* The key can be taken out only when reverse gear is engaged.
- G. *Garage.* Ignition, etc., is switched off but the gear-shift lever is unlocked. The key cannot be removed in this position.
- K. *Driving.* Ignition is on. Current is supplied via the ignition switch to fuel pump, flashing turn indicators, fan motor, windscreen wipers, horn and charge indicator light.
- S. *Starting.* This position has a spring return action. To prevent engagement of the starter while the engine is running, position S has a catch. Consequently, the ignition key must always be turned back to position G before making a new attempt to start or if the engine stalls.





### Gear-lever and ignition lock

The steering-column stand is secured by means of two screws to a bracket under the instrument panel. These screws have waists and are locked with roll pins. They can be loosened enough to allow adjustment of gear positions, but if steering-column stand is to be removed, the roll pins must first be knocked out with an arbor. The gear-lever lock consists of a twist stop, knurled on the inside, secured to the gear-shift shaft with two clamping screws and one stop screw. The twist stop has a hole into which the lock plunger slides when the gear-shift lever is locked.

#### NOTE!

Readjustment of the twist stop for the lock plunger is essential whenever the gear-shift mechanism has been dismantled and after adjustment of gear positions.

- Adjustment of gear positions can now be carried out by moving steering-column stand in the ordinary way. If the ignition key is turned to position G, thereby releasing the twist stop, the gear-shift mechanism can then be dismantled.

#### NOTE!

The clamping screws of the twist stop are always accessible when 1st gear is engaged and the stop screws when reverse gear is engaged.

### ADJUSTMENT OF TWIST STOP

After adjustment of gear positions, readjustment of twist stop is called for. The procedure is the following:

- The twist stop is marked on the side that is to face towards the steering wheel. The marking shows for which version the twist stop is designed, e. g. V-4 means left-hand drive, 4-speed.
- Engage reverse gear and push twist stop up. Simultaneously, turn ignition key to locked position (L) and check that lock plunger finds its position in twist stop.
- The twist stop now hangs on the lock plunger. Move twist stop up about 0.08 in. (2 mm) and tighten stop screw slightly. NOTE! Do not tighten screw up too hard, its purpose being merely to hold twist stop during adjustment.
- Turn ignition key to position G and engage 1st gear, enabling two clamping screws on twist stop to be tightened. Then engage reverse gear and loosen stop screw. Return to 1st gear and tighten clamping screws permanently. Now engage reverse gear again and tighten stop screw to prevent it from loosening.

Note! On right-hand drive, 4-speed cars there is a spring on the gear-shift shaft which serves as a reverse catch. This spring must be in place when twist stop is adjusted.

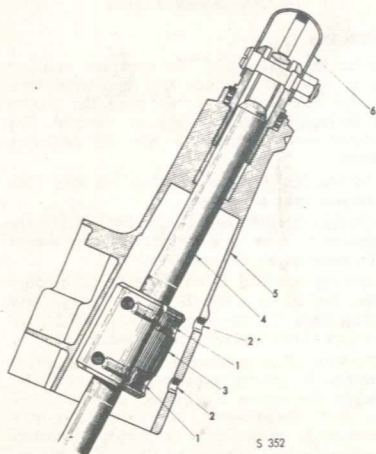

Gear-lever lock, cut-away view

- Clamping screw
- Adjusting hole
- Twist stop
- Gear-shift shaft
- Steering-column stand
- Gear-shift lever

### REMOVAL OF TWIST STOP

- Engage 1st gear, thus making two clamping screws on twist stop accessible through the holes (2) on bottom of steering-column stand — see fig. Undo these screws with a 3/16" hex. spanner.
- Engage reverse gear and turn ignition key to locked position (L), enabling the stop screw which holds the twist stop to be loosened through one of the holes (2) in the steering-column stand. Which hole to use depends on whether the car has 3-speed or 4-speed drive.

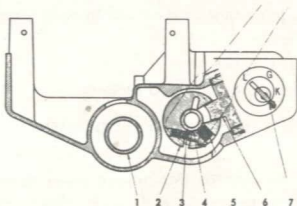

Twist stop and lock plunger

- Steering column
- Twist stop
- Clamping screw
- Gear-shift shaft
- Stop screw
- Lock plunger
- Lock cylinder with key





**IGNITION LOCK**

**DISASSEMBLY**

1. Insert ignition key and turn to right-hand edge of "ASSA" mark. (See fig.).
2. When key is in this position, the catch pin in the lock cylinder can be pressed in by inserting a wire picklock in a hole on the underside of the steering-column stand. See fig.
3. Pull out the lock cylinder and remove lock plug through hole for cylinder.
4. Gear-lever lock can now be removed after removal of retaining screw.

**NOTE!**

When lock cylinder is removed the key has no stop positions and can thus be turned a complete revolution. If key takes up incorrect position, locking pins inside the cylinder may get in the way so that key cannot be returned to working position. To remedy this, tap key and lock cylinder lightly against a wooden object with the retainer on outside of cylinder turned upwards.

If the key has been lost or if it is necessary to remove the lock cylinder, the cylinder must be drilled before the catch pin can be pressed in. Drill a 0.12 in. (3 mm) hole in the cylinder to a depth of about 0.4 in. (10 mm) as illustrated.

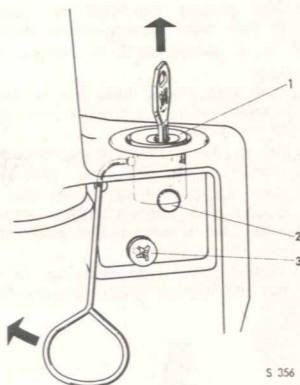

S 356

**Removing lock cylinder.**

1. Lock cylinder
2. Lock plug
3. Retaining screw

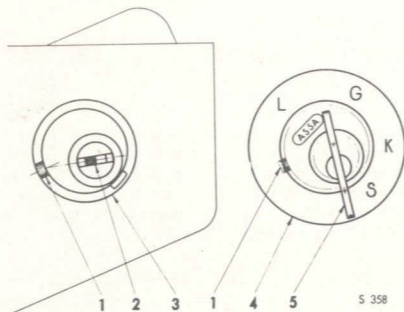

S 358

**Position of key and lock plunger during assembly or disassembly.**

1. Catch pin
2. Position of locking pin during assembly of lock cylinder.
3. Gear-lever lock
4. Sign-plate
5. Position of key during assembly of lock cylinder.

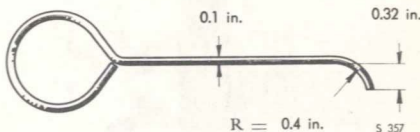

**Wire picklock**

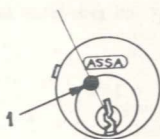

S 364

**Drilling lock cylinder for removal when key is missing.**

1. Hole, diameter 0.12 in. (3 mm), depth 0.4 in. (10 mm).





## REASSEMBLY

## NOTES

1. Slide lock plunger into gear-lever lock and then fit lock into steering-column stand.
2. Insert screw and drive it in slightly. Insert lock plug.
3. Using flat-nose pliers, turn pin in lock so that it coincides with groove in end of lock cylinder — see fig.
4. Turn key so that it comes to right-hand part (see "ASSA" mark), and press catch pin in.
5. Now place sign-plate over pin so that it is kept in pressed-in position. Adjust sign-plate position so that it fits against retaining lug on outside of cylinder.
6. Insert lock cylinder with sign-plate in gear-lever lock and tighten screw permanently.

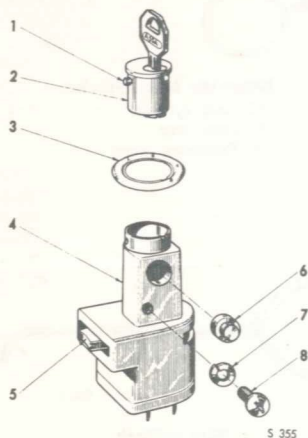

S 355

**Lock cylinder and gear-lever lock.**

1. Catch pin
2. Lock cylinder
3. Sign-plate
4. Gear-lever lock
5. Lock plunger
6. Lock plug
7. Spring washer
8. Cross-recess screw



## DESCRIPTION

The Saab is fitted with a hydraulic footbrake system acting on all four wheels and a mechanical handbrake acting on rear wheels only.

### GENERAL

The Saab is fitted with a hydraulic footbrake system acting on all four wheels, and with a mechanical handbrake acting on the rear wheels only.

Three types of brakes are in use, and are hereinafter referred to as type I, type II and type III. They are fitted in cars with the following chassis numbers:

#### Type I

Saab 95 up to and incl. chassis No. 3130  
Saab 96 and  
GT-750 up to and incl. chassis No. 134999

#### Type II

Saab 95, chassis No. 3131—10800  
Saab 96 and  
GT-750, chassis No. 135000—201400

#### Type III

Saab 95 as from chassis No. 10801  
Saab 96 and  
96 Sport as from chassis No. 201401

### TYPES I AND II

When the brake pedal is depressed the movement is transmitted to the master cylinder by a push-rod, and compression of the brake fluid creates a pressure in the wheel cylinders. Two cylinders are fitted to each of the front wheels, see fig., each cylinder actuating an individual brake shoe. When braking, with the car moving forwards, the pistons move tangentially in the same direction as that in which the wheel rotates, thus expanding the shoes against the drum.

The rear-wheel brakes each have a single cylinder, see fig., which in brakes of type I moves in an elongated hole in the backplate. When braking with the car moving forwards, the piston moves in the same direction as that in which the wheel rotates and expands one brake shoe against the drum. Simultaneously, the body of the cylinder is forced in the opposite direction and presses the other brake shoe against the drum. In brakes of type II, however, the cylinder is rigidly attached to the backplate and contains two pistons, each of which actuates a brake shoe. See fig.

The main cylinder comprises a cylinder body and a piston as illustrated. A spring-loaded inlet outlet valve is located at one end of the cylinder. This valve prevents return of brake fluid pumped into the system during bleeding. The design is such that a pressure is always maintained in the brake lines. When the pedal is released after normal braking the valve is opened by the fluid returning to the master cylinder. Pressure drops in the lines, to the point at which the spring can close the valve. The pressure remaining in the lines corresponds to the spring pressures. A bypass port in the master cylinder connects it with the fluid reservoir so that the system is always full. This bypass port also allows for contraction or expansion of the fluid due to temperature changes. It is important that this passage does not become choked with foreign matter, which can occur if the piston does not return fully when the pedal is released.

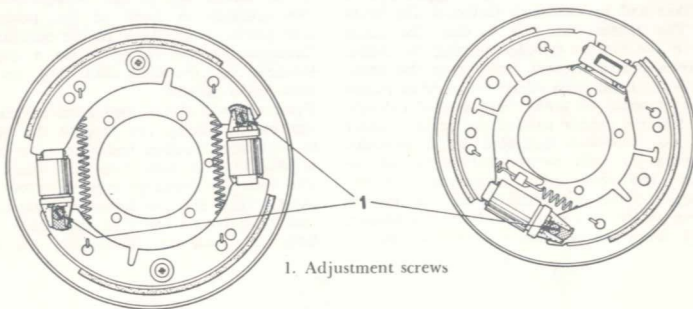

Front-wheel brakes, type I

Rear-wheel brakes, type I



There are certain differences between the master cylinders in type I and type II, but the principle is the same in both cases.

A reduction valve is incorporated in the rear-brake lines in type II, thereby achieving the optimum distribution of brake effect between the front and

rear wheels. This valve is not fitted on the Saab 95, which has a different weight distribution.

The handbrake lever is placed between the front seats. Movement of the lever is transmitted to the levers of the rear-wheel cylinders by steel wires in spiral sheathing.

### TYPE III, TWO-CIRCUIT BRAKE SYSTEM

The brake system is of two-circuit type and comprises two leading shoe, self-adjusting front brake shoes, each of which is actuated by its own single-acting wheel cylinder, and rear brake assemblies with manually adjusted brake shoes, both of which are actuated by a double-acting cylinder. The rear brakes are the same as in type II.

The mechanical handbrake acts on the rear wheels, lever movement being transmitted by steel wires. The handbrake is adjusted manually. When the brake pedal is depressed, the master cylinder pistons apply a force to the brake fluid, which is displaced through pipes and flexible rubber hoses to the cylinders at the brake shoes, causing the shoes to contact the drums. The master cylinder has two pistons, which work simultaneously but independently so that one operates the left front wheel and right rear wheel and the other the right front wheel and left rear wheel. Consequently, if leakage occurs as a result of damage to the brake system, braking effect will be lost only on one diagonal pair of wheels, while the brakes will still be applied to the other pair. Leakage is revealed by a tendency for the car to swerve towards the side where the brake power is still effective upon application of the brakes and by excessive travel of the brake pedal. The reason for this is that the brake piston in the master cylinder serving the damaged circuit moves without influencing the brake shoes. Every application of the brake thus pumps a certain amount of brake fluid out of the system, but as the upper part of the brake cylinder forms two chambers separated by a partition, the system can only be emptied as far as the partition. The brake fluid remaining for the undamaged circuit is sufficient for the car to be driven safely to a garage to have the damage repaired. Since the two-circuit brakes operate on

the diagonal wheels, maximum braking effect is ensured and affords greater safety when steering the car, as one front wheel and one rear wheel always roll freely at the same time and are not locked.

The brake lines to the rear brakes on the Saab 96 are fitted with pressure-regulating valves which prevent premature locking of the rear wheels. This is due to the fact that when the master cylinder pressure has reached a certain figure as a result of heavy brake application, the valves prevent further fluid from passing to the rear brakes. Any additional pressure is then transmitted only to the front brakes.

### Master cylinder, two-circuit brake

The tandem master cylinder comprises a body housing a primary piston (10) and a secondary piston (14) which are actuated by the push-rod (31) from the brake pedal. The pistons are held apart by a spring (18), the distance between them being determined by the clip (17) and the retaining pin (19). The secondary piston has a primary cup (12) and a secondary cup (15). Fitted behind the primary cup is a dished piston washer (13) which prevents the cup from being extruded into the feed holes in the flange. The primary cup (21) of the primary piston also has a dished piston washer (22) and a secondary cup (26), which keys against the piston rod and prevents leakage of brake fluid. The spring (9) returns the piston to the initial position. Outlet valves are fitted in the two outlets (1 and 2) —

When the brake pedal is depressed, the push-rod (31) actuates the primary piston, the thrust being transmitted by the spring (18) to the secondary piston, which forces brake fluid out through the non-return valve to one brake circuit. As the secondary chamber pressure rises, the spring thrust between the pistons is overcome and further effort on the brake pedal compresses the spring slightly, causing brake fluid to be forced out to the second brake circuit. The pressure in front of the primary piston also reacts on the back of the secondary piston. Consequently, the latter forms a partition and balances the pressures until they are equal in both brake circuits.

Upon removal of the load from the brake pedal, the return spring (9) thrusts the pistons back to the initial position faster than the brake fluid is able to flow back from the wheel cylinders. The main (or primary) cups therefore move forward a little and the dished washers uncover the feed holes behind the cups and admit brake fluid from the reservoir. Meanwhile, the brake-shoe

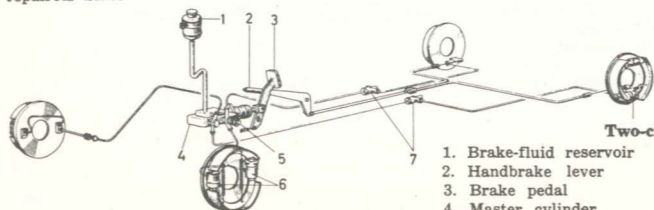

Two-circuit brake system

- |                          |   |
|--------------------------|---|
| 1. Brake-fluid reservoir | 5. Stop-light contact                       |
| 2. Handbrake lever       | 6. Wheel cylinders                          |
| 3. Brake pedal           | 7. Pressure-regulating valve (Saab 96 only) |
| 4. Master cylinder       |   |





pull-off springs pull back the brake pistons, whereupon brake fluid flows back through the non-return valves which are open. The brake fluid then passes back to the reservoir via the bypass ports (3) and (6), which also compensate for contraction or expansion of the brake fluid due to temperature changes. When the brake shoes have been returned, the nonreturn valve closes and any residual pressure is released through the hole (43) in the valve. The purpose of the non-return valve is to prevent the re-entry of brake fluid from the wheel cylinders when bleeding the brakes. This ensures that a fresh charge of brake fluid, completely purged, will pass from the reservoir and through the system at each stroke of the brake pedal. In the event of a leak occurring in the system operated by the primary piston, the spring (18) is compressed until the primary piston strikes the secondary piston. The latter can then function normally.

If leakage occurs in the circuit operated by the secondary piston, the secondary piston will be thrust forward by the primary piston and spring until it touches the bottom of the cylinder bore, whereupon brake fluid can be pressed out into the intact circuit.

## FRONT BRAKES

The front brake shoes are of the self-adjusting type, and each one is operated by its own single-acting brake cylinder. The shoes are engaged in grooves in the wheel cylinder piston and opposing wheel cylinder, where they are free to slide and thus able to centralize in relation to the drum. Each shoe carries its own automatic

adjustment device, comprising an adjuster lever (4), secured to the brake shoe by a peg (13) at one end and with serrations at the other end. The lever is held to the brake shoe by two friction washers (5), a retaining pin (10), loaded by a spring (11), and a spring retainer (12). One end of the pull-off springs (9) for the brake shoes is designed as a clicker catch which engages in the serrations of the adjuster lever. On the backplate is provided a peg (3), which slides in a groove in the centre of the lever. The brake shoes are held against the backplate by a steady spring, a spring washer and a steady pin (2). They are also held to the wheel cylinder piston by means of a piston locking spring (7).

The backplate peg (3) always has a certain amount of clearance in the adjuster lever groove and this determines how much free movement there will be between brake linings and brake drum when the brake shoes are "off". Upon application of the brakes, the shoe is forced out against the drum by the piston and is accompanied by the adjuster lever, so that the peg takes up a new position in the groove. As the brake linings get worn, the automatic adjustment device becomes effective. Further travel of the

brake shoe together with the adjuster lever will result in the detention of the lever in the middle by the peg (3). However, since the lever is carried in a bearing (2) at one end, it will turn there and will slide between the friction washers (4) at the other end. The friction of these washers will now hold the adjuster lever in this new position when the brake shoes return to the off position. When the adjuster lever has travelled far enough, the clicker catch of the pull-off spring will drop into the next serration and thus ensure positive retention of the adjuster lever. When the brake shoe returns to the off position, it will move only as much as is allowed by the free movement at the peg, which is just enough to ensure that the brake shoe runs clear of the drum. In order to prevent any variation in the brake-pedal stroke due to the wheel cylinder piston working back into the cylinder by itself, the piston is connected to the brake shoe by a piston-locking spring.

## MASTER CYLINDER

### OVERHAUL INSTRUCTIONS, GENERAL

At intervals not exceeding three years or 40,000 miles (60,000 km), or at every third change of a brake lining, whichever occurs first, renew all rubber cups and seals throughout the hydraulic system.

When dismantling the brake system, or any part thereof, this must be done under conditions of scrupulous cleanliness. Clean off dirt and grease before removing any units. Do not swirl a dismantled unit in petrol, paraffin or trichlorethylene, etc., because these solvents will ruin the rubber parts. Dismantle units on a bench covered with a sheet of clean paper. Do not handle internal parts with dirty hands, particularly not rubber items. After dismantling, place all metal parts in a tray of clean brake fluid to soak. Having done this, dry off with a clean, lint-free cloth and lay out in order on a sheet of clean paper. To ensure unerring reliability, we would recommend that all rubber parts be replaced by new ones, these being readily available in the form of repair kits containing all the rubber parts required for each particular unit.

The main bodies of units may be swilled in industrial methylated spirit or brake fluid, but if spirit is used all grooves and similar must be wiped dry before assembling. All internal parts should be dipped in brake fluid according to Spec. S.A.E. 70 R 3 and assembled wet. When assembling rubber parts use the fingers only. Stores departments should exercise special care in handling spare parts to ensure that no damage occurs which would affect their correct functioning. Rubber parts should be stored in a cool, dark place, thoroughly cleaned from dirt.

There are some differences between the master cylinders in type I and type II, but the principle is the same in both cases. The descriptions below are applicable to both types unless otherwise stated. Type III, on the other hand, differs considerably, and will therefore be described separately.





## REMOVAL, TYPES I, II AND III

1. Empty the brake-fluid reservoir and disconnect the inlet line from the master cylinder. In the case of the later design with hose, merely detach the reservoir from its holder and empty it.
2. Disconnect banjo-connections for outlet brake lines from master cylinder.
3. Unscrew left half of toeboard and rest it against wheelhouse wall. On cars with right-hand drive, unscrew right half of toeboard.
4. Remove rubber boot from push-rod, or back off locknut and detach push-rod from fork on brake pedal.

### TYPES I AND II

Remove the three nuts holding master cylinder; they are accessible from the engine compartment.

### TYPE III

Remove the two bolts retaining master cylinder. The lower one is a stud bolt, the nut being accessible from the engine compartment, and the upper one a screwbolt, accessible from inside the car.

6. Remove the master cylinder.

## INSTALLATION, TYPES I, II AND III

1. Cover all openings to prevent entry of foreign matter into cylinder during installation work.
2. Attach brake cylinder to cowl plate by fitting nuts or bolts, as applicable.
3. Refit rubber boot to push-rod. Reassemble push-rod if it has been divided.
4. Reconnect filler pipe or replace brake-fluid reservoir with hose.
5. Connect outlet brake lines and refill system with brake fluid.
6. Bleed the system.
7. Adjust brake-pedal play.

## OVERHAUL OF MASTER CYLINDER, TYPES I AND II

The components of the master cylinder may be inspected and replaced without removing it from the car.

1. Plug the opening in fluid reservoir with a suitable wooden plug.
2. Turn back mat and remove toeboard.
3. Open one bleeding nipple to release pressure in lines.
4. Back off locknut and disconnect push rod, see ill.
5. Remove retainer and washer.
6. **Extract piston.** The seal located on the piston will accompany it.
7. Remove piston cup and disc between cup and piston.
8. Extract spring; valve and spring seat will accompany it.

9. Seal (type I) can be extracted with a suitable hooked tool.
10. Clean all parts in methylated spirits. Avoid bringing rubber parts in contact with gasoline or lubricating oil.

## CHECKS

1. Check that cylinder bore is not scored.
2. Check that rubber parts are not defective.
3. Check that piston moves freely in cylinder.
4. Check that drillings in piston and cylinder wall are clean. Use a wire with a diameter of about .02 in. (0.5 mm).
5. Replace damaged parts.

## REASSEMBLY

Lubricate bore of master cylinder and other surfaces with brake fluid and reassemble, observing strict cleanliness.

1. Press in seal (type I)
2. Locate valve, with rubber insert, on spring; fit spring seat, and push assembly into cylinder.
3. Press in piston cup (with disc) and piston. Check that seal is correctly located on piston.
4. Refit washer and retainer.
5. Refit rubber boot on push-rod. Insert push rod in piston and ease bellows on to cylinder. Secure with wire ring (type II).
6. Reconnect push-rod halves.
7. Remove plug from fluid reservoir, reconnect pipe and bleed system.
8. Adjust pedal movement and secure with locknut.
9. Fit toeboard and fold back the mat.

## OVERHAUL OF MASTER CYLINDER, TYPE III

The master cylinder should only be dismantled if there is no exchange system for this part.

## DISMANTLING

1. Detach the rubber boot (11) from its retaining plate (8) together with the push-rod (31). Bend the four ears of the boot retaining plate away from the mounting flange and remove it from the end of the cylinder.
2. Depress the spring retainer (30) and, using a small screwdriver, unwind the "Spirolox" circlip (29) from the groove of the primary piston, taking care not to distort the coils; remove the spring retainer (30) together with the spring (9).
3. Remove the circlip (28), taking great care not to damage the surface finish of the primary piston (10). Lightly tap the mounting flange of the cylinder body on the bench, and remove the nylon guide bearing (27), the secondary cup (26) and the plain washer



- Using special circlip pliers with long, narrow jaws, remove the inner circlip (24), again taking great care not to damage the surface finish of the primary piston.
- Removal of the circlip (24) will allow the withdrawal of both pistons together with piston stop (23).
- Compress the intermediate spring (18) together with spring holder (20) and drive out the retaining pin (19), using a suitable pin punch. This will separate the two pistons (10 and 14) and allows the withdrawal of the spring (18) and spring holder (20).
- Remove the primary cups (12 and 21) together with the piston washers (13 and 22) from the primary and secondary pistons. Remove the secondary cup (15) from the back of the secondary piston. Do not attempt to remove the clip (17) from the secondary piston, as this part is permanently peened in position.
- Unscrew the outlet adapters (46) and remove them together with the gaskets.
- Withdraw the non-return valves, comprising spring (41), valve body (42) and outlet valve spring (44). Take care not to distort the outlet valve spring (44) during removal from the valve body.
- Remove the six bolts retaining the reservoir lid (5) and take off the lid together with the gasket.

#### INSPECTION

- Check that cylinder bore is not scored.
- Check with a piece of thin steel wire that bypass holes are clean.
- Check all parts, and renew any defective ones. Internal rubber parts should be exchanged for new ones, which are available in suitable kits.

#### ASSEMBLY

Before reassembling the master cylinder, dip all part in brake fluid.

- Using the fingers only, stretch the secondary cup (15) over the big end of the secondary piston with the lip pointing towards the peened clip. Gently work round the cup with the fingers to ensure correct bedding.
- Locate the piston washer on the secondary piston spigot as illustrated in the fig. below so that the convex edge is towards the back of the cup. Using the fingers only, ease the primary cup (12) over the nose of the spigot and into the groove, with the lip of the cup pointing away from the head of the piston.
- Adopt the same procedure with the main cup (21) and piston washer (22) of the primary piston. Ease the spring holder (20) into the end of the spring (18) and fit the other end of the spring over the rear of the secondary piston (14).
- Locate the retaining pin (19) in the hole in the primary piston, but do not push fully home. Compress the spring until the secondary piston clip (17) is visible. Place the clip in position in the primary piston and secure it by pushing the retaining pin fully home. Release the spring and check that the spring holder (20) is correctly positioned.
- Ease the pistons gently into the cylinder bore and slide the piston stop ring (23) over the primary piston. Fit the circlip (24) in the inner groove using special circlip pliers with long, narrow jaws and check that it is correctly located. Take great care not to damage the surface finish of the primary piston since this could cause leakage past the secondary cup.
- Fit the plain washer (25) into the cylinder bore against the circlip, followed by the secondary cup (26).
- Place the nylon guide bearing (27) in position and secure with the outer circlip (28).
- Mount the spring retainer (30) with the return spring (9) on the primary piston (10). Compress the spring until the piston circlip groove is visible behind the spring retainer and locate the "Spirolox" circlip.
- Fit boot retaining plate (8) in position over the mounting flange of the cylinder and bend the four ears over to hold it in position. Before fitting the rubber boot (11), smear the small end of the push-rod (31) with silicon grease to ensure that the rod will be free to rotate when assembled.
- Ease the push-rod into position in the rubber boot and fit the boot into its groove.
- Ease the spring clip (44) into the non-return valve body and check that it is correctly positioned. Fit the return spring over the valve body and locate the parts within the outlet port, inserting the spring first.
- Screw the outlet adapter (46), together with the gasket (45), into the outlet port and torque to 33 ft-lb (4.5 kpm). Adopt the same procedure for the remaining outlet port.
- Place the lid of the brake-fluid reservoir (5) in position together with the gasket, and secure in position with the six bolts, torquing them to 4 ft-lb (0.55 kpm).



**GENERAL**

All work on the brake system must be done under conditions of scrupulous cleanliness

At intervals not exceeding three years or 40,000 miles (60,000 km), or at every third change of a brake lining, whichever occurs first, renew all rubber cups and seals throughout the hydraulic system.

**Type I**

The front wheel cylinders, contain a single piston with rubber cup, a spring and a cup filler. Fluid pressure thrusts the piston against the brake shoe.

The rear wheel cylinders, contain inner and outer pistons. The inner piston is actuated by fluid pressure and the outer by the handbrake lever. Both pistons are fitted with a rubber seal.

**TYPES II AND III**

The front wheel cylinders, contain a single piston with a rubber seal and an external rubber boot. The piston is forced against the brake shoe by fluid pressure.

The rear wheel cylinders each have two pistons, actuating separate brake shoes. The pistons are fitted with seal rings and external boots.

**FRONT WHEEL CYLINDERS, TYPE I**

**REMOVAL**

1. Jack up car and remove wheel, brake drum and brake shoes with backplate.
2. Disconnect brake hose from wheel cylinder.
3. Disconnect hose between cylinders.
4. Remove cylinders by backing off nuts on rear side of backplate.

**DISASSEMBLY**

See illustration of disassembled wheel cylinder. If piston and cup are extracted first with the aid of a thin wooden peg, the cup filler and spring will be freed.

**CHECKS**

1. Clean and dry all parts.
2. Check that cylinder bore is not scored.
3. Check that no rubber cups or seals are defective. Use of unsuitable brake fluid can cause rubber cups to swell by up to 50 %. A rubber part which is even slightly swollen or damaged must be replaced.

**REASSEMBLY**

Observe strict cleanliness when reassembling wheel cylinders.

Lubricate cylinder bore, cups and pistons with brake fluid before reassembling.

Reassemble wheel cylinder as illustrated. Check that filler is facing the right way when inserted.

**INSTALLATION**

1. Fix cylinders to backplate with nuts and spring washers.
2. Reconnect brake pipe between cylinders.
3. Reconnect brake hose, inserting a non-defective copper gasket at threaded connection. It is best to use a new gasket, but an excessively hard gasket can be annealed and re-used.
4. Refit backplate, brake shoes, brake drum and wheel. Check when refitting drum that Woodruff keys remain in axle keyway.

**FRONT WHEEL CYLINDER, TYPES II AND III**

**REMOVAL**

1. Jack up car and remove wheel, brake drum, brake shoes and backplate.
2. Disconnect brake hose at wheel cylinder.
3. Disconnect hose between cylinders.
4. Remove cylinder by backing off bolts from rear of backplate.

**DISASSEMBLY**

See illustration of a disassembled cylinder. If rubber boot is pulled free of cylinder and piston is drawn out, the seal can then be removed from the piston. Use fingers only.

**CHECKS**

1. Clean all part with brake fluid.
2. Check that cylinder bore is free of scoring.
3. Check that no rubber cups or seals are defective. Use of unsuitable brake fluid can cause rubber cups to swell by up to 50 %. A rubber part which is even slightly swollen or damaged must be replaced.

**REASSEMBLY**

Lubricate all parts with brake fluid before reassembly.

Fit a non-defective seal on the piston, checking that it is right side up. See ill. Use fingers only. Refit piston in cylinder and replace the rubber boot.

**INSTALLATION**

1. Refix cylinders to backplate with bolts and spring washers.
2. Reconnect brake pipe between cylinders.
3. Reconnect brake hose, inserting a non-defective copper gasket at threaded connection. It is best to use a new gasket but an excessively hard gasket can be annealed and re-used.
4. Refit backplate, brake shoes, brake drum and wheel. Check when refitting drum that Woodruff keys remain in axle keyway.





## REAR WHEEL CYLINDERS, TYPE I

### REMOVAL

1. Remove wheel, brake drum and brake shoes.
2. Disconnect return spring and handbrake wire from lever.
3. Disconnect brake pipe by detaching drilled screw from banjo connection on rear of backplate.
4. Remove outer piston and rubber boot at rear of backplate.
5. Remove cylinder from backplate.

### DISASSEMBLY

See illustration of disassembled cylinder. Removal of the outer piston and cylindrical pin releases the lever carried on the pin. The inner piston and cup may then be removed with the aid of a thin wooden pin.

### CHECKS

1. Clean and dry all parts.
2. Check that cylinder bore is not scored.
3. Check that no rubber cups or seals are defective. Use of unsuitable brake fluid can cause rubber cups to swell by up to 50%. A rubber part which is even slightly swollen or damaged must be replaced.

### REASSEMBLY

Observe strict cleanliness when reassembling wheel cylinders

Lubricate cylinder bore, cup and pistons with brake fluid before reassembly.

Lubricate cylindrical pin with a little grease.

### INSTALLATION

1. Refit cylinder and work boot into place, exactly as shown.
2. Reconnect brake-hose banjo connection, with copper gaskets.
3. Reconnect handbrake wire to brake lever, and secure bolt by attaching closed loop of return spring.
4. Refit brake shoes, brake drum and wheel. Be careful not to damage shaft seals.

#### NOTE

Always bleed the system after reassembly, if a pipe or wheel cylinder has been removed.

## REAR WHEEL CYLINDERS, TYPES II AND III

### REMOVAL

1. Remove wheel, brake drum and brake shoes.
2. Disconnect handbrake wir from lever.
3. Disconnect brake pipe from rear of backplate.
4. Remove wheel-cylinder retainer and bleed nipple from rear of backplate.
5. Remove wheel cylinder.

### DISASSEMBLY

1. Remove rubber boots from cylinder.
2. Draw out pistons.
3. Remove rubber cups from pistons.

### CHECKS

1. Clean and dry all parts.

#### NOTE

Do not allow gasoline or oil to come in contact with rubber parts.

2. Check that cylinder bore is free of scoring.
3. Check that no rubber cups or seals are defective. Use of unsuitable brake fluid can cause rubber cups to swell by up to 50%. A rubber part which is even slightly swollen or damaged must be replaced.

### REASSEMBLY

Observe strict cleanliness when reassembling wheel cylinder. Lubricate cylinder bore, cups and pistons with brake fluid before reassembly. Reassemble as illustrated.

### INSTALLATION

1. Refit wheel cylinder to backplate
2. Reconnect brake hose.
3. Refit brake shoes, brake drum and wheel. Avoid damage to shaft seals.
4. Reconnect handbrake wire.

Do not fail to bleed the system after reassembly, if a pipe or wheel cylinder has been removed.

### INSTALLATION

1. Refit the wheel cylinder to the backplate and locate the retaining ring and bleed nipple. Note that there are two types of attachment for wheel cylinders as illustrated.

A wheel cylinder with roll pin can also be fitted to an older backplate if the pin is removed.

On the other hand, the old type of wheel cylinder must never be fitted to a backplate of the new design, as in this case it would be impossible to secure the cylinder.





2. Reconnect the brake line.
3. Refit the brake shoes, drum and wheel, taking great care not to damage the axle seal.
4. Reconnect the handbrake wire, bearing in mind that the handbrake lever must be located with the bent part turned upwards — see fig. Note that there are two types of lever, return spring and rubber boot, and be sure to fit the correct combination. See spare-parts list.

Remember to bleed the system after reassembly whenever a brake line or wheel cylinder has been removed.

## FLUID RESERVOIR AND BRAKE LINES

### FLUID RESERVOIR, TYPE I

The fluid reservoir is placed at the side of the engine compartment, being fixed to the radiator shroud by a clamp. The reservoir is connected to the master cylinder by a double-walled, 5/16-in. steel pipe of Bundy type. The pipe should be inclined downward to the master cylinder to avoid the occurrence of air locks. Make sure that the breathing holes in the reservoir cover are not choked.

### FLUID RESERVOIR, TYPES II AND III

The fluid reservoir, of plastic, is placed on the left side of the engine compartment in l.h. drive cars and is fixed to the radiator shroud by a clamp. The reservoir is connected to the master cylinder by a rubber hose retained by clamps at both reservoir and cylinder. In l.h. drive cars, the hose is also held by a clip fixed to one of the steering-gear retaining bolts. The hose should be inclined downward to the master cylinder to avoid the occurrence of air locks. Check that the breathing holes in the reservoir cover are not choked.

#### NOTE

The hose clamp under the fluid reservoir must not be tightened so hard as to involve a risk of distorting the plastic connection or reducing fluid flow.

### BRAKE LINES

The brake pipes are of 3/16 in. Bundy tube. The ends of the pipes are flanged and fitted with compression nuts, which must be passed onto the pipe before the ends are flanged. For a leakproof joint it is important for the pipes to be properly flanged, as shown. It is a matter of safety that all pipes, hoses and connections in the brake system be kept in first-class order at all times. Check regularly that hoses have not been damaged by flying stones or abrasion. Pipes should also be fitted so that they cannot rub against anything. Pipes are attached to the body by flat clips and should be

protected by rubber grommets where they pass through metal panels.

The rubber grommets are slit and can be eased onto pipes which are already flanged and installed. See to it that pipes and handbrake wire at the inclined panel under the rear seat are correctly installed, so that they cannot chafe against one another, and that the pipes cannot be damaged by the seat cushions.

Tighten all pipe and hose connections to achieve leak-free joints. Inspect copper gaskets in connections and replace if defective. Gaskets which have become excessively hard and do not seal properly may, however, be annealed and re-used.

When installed, pipes should fit well at both ends and at clips. Never try to stretch a badly-fitted pipe by means of the compression nuts, nor to bend a pipe after installation. Both these practices can introduce stresses resulting in leakage, pipe fracture or stripped threads.

For brakes of type I, flange pipes as per A in the fig. For brakes of type II, flange pipes at connections to hoses as per A in fig., otherwise as per B. The nuts used at connections to hoses in pattern II are of different pattern to those at other connections.

### BRAKE HOSES

The brake system incorporates two hoses at the front end. These form the communication between the pipe at the body and the wheel cylinders. At the rear end, one hose is provided in types I and II, and two in type III. These constitute the flexible connection between the pipe at the body and the one attached to the rear axle. The front and rear hoses are of different lengths and are therefore not interchangeable. Hoses for brakes of type I may not be used with type II.

Fit hoses with the wheels freely suspended and aligned straight ahead. When tightening brake connections hold up the hose nipple to prevent the hose twisting and changing position.

#### WARNING

Always fit brake hoses so that it is impossible for them to come into contact with wheels or other moving parts. Check that clearance is adequate even with the wheels at full lock.

### INSPECTION

All brake hoses and pipes should be inspected every 10,000 miles (15,000 km) for any signs of leakage, chafing or other deterioration. At the slightest sign of damage, renew the hose or pipe. For safety's sake, renew all brake hoses every 40,000 miles (60,000 km) or every three years.



## REDUCTION VALVE,

### STOP-LIGHT SWITCH

The stop-light switch is incorporated in the hydraulic system and actuated by brake pressure. It is located in the front pipe connection to the master cylinder, except on l.h. drive cars with patt. I brakes, in which it is located in the connection at the left wheelhouse.

### PRESSURE-REGULATION VALVES

The Saab 96 and GT 750 models with brakes of type II are fitted with one pressure-regulating valve, while two such valves are installed in models with brakes of type III. The valves, which are bolted to the floor plate under the rear seat, limit the hydraulic pressure transmitted to the rear brakes so that the braking effect is suitably distributed. The valves are preset for a given pressure and cannot be adjusted. When the fluid pressure reaches 450 p.s.i. (31.6 kg/cm<sup>2</sup>), the spring force acting on the piston is overcome, causing the piston to travel and close the passage to the rear brakes. Any additional pressure then generated thus increases the braking effort on the front brakes only, while the pressure on the rear brakes remains constant.

## BRAKE DRUMS AND SHOES

### REMOVAL OF BRAKE DRUM AND CHECKING OF BRAKES

1. Jack up car.
2. Remove wheel.
3. Wash underside of fenders if necessary, removing all dirt which might drop into bearings during work.
4. Release handbrake and check that brake shoes are clear of drums and cannot be damaged when the drum is removed.

#### Types I and II

Possibly, it will be necessary to set back the shoes with the adjusting screws.

#### Type III

In this case, the front brake shoes are of self-adjusting type. Consequently, the following procedure must be adopted for readjusting the shoes:

- a) Pass a screwdriver into the extra hole in the brake drum and then into the hole (6) in the brake shoe.
  - b) Bearing against the hub nut, press the brake drum and brake shoe *against* the normal direction of rotation, until you hear a grating sound, indicating that the shoe has been forced back and the clicker catch lets go. Re-adjust both shoes before removing the brake drum.
5. Remove brake drum, using puller 784002 as illustrated.

#### NOTE

Never replace a brake lining on one side only.

### MACHINING BRAKE DRUMS

If brake drums are moderately scored to an equal degree on both sides, this does not affect brake effect or life of linings. But if the drum on one side only is scored, or if both drums are seriously scored, they should be replaced or possibly re-machined. Replacement or machining is also necessary if out-of-round is detected, which is usually betrayed by jumping of the brake pedal when braking. The front drum may be turned to a maximum diameter of 9.059 in. (230.1 mm.) and the rear to maximum 8.059 in. (204.7 mm).

### FRONT AND REAR BRAKE SHOES

#### TYPES I AND II

#### REMOVAL OF BRAKE SHOES

1. Be careful to retain the pistons in the wheel cylinders while working, with the aid of a piece of wire, for example.
2. Remove springs holding brake shoes against backplate (not present in brakes of type I).
3. Lift brake shoe away from wheel cylinder, using a screwdriver or similar tool, as illustrated.
4. Remove adjustment cam and bearer (but not on rear brakes of type II, which have a different adjusting arrangement).
5. Lift out brake shoes and unhook springs.

#### REPLACEMENT OF LININGS

1. Remove old linings.
2. Wash shoes in gasoline or kerosene and blow with compressed air.
3. Place new linings on shoes and fix them with two rivets in center.
4. Fix other rivets, proceeding from center out to ends. Stretch lining well to secure good contact with shoe. Any clearance between lining and shoe may adversely affect braking action and cause troublesome noise.

#### IMPORTANT

Use only Saab linings or makes recommended by SAAB.

#### NOTE

To secure perfect contact between lining and drum, and speedy breaking-in, linings should be ground after riveting to radius of .005 in. (0.12 mm) less than that of the drum. This is particularly important if the drum has been machined. This grinding requires special equipment.



## INSTALLATION OF BRAKE SHOES

1. Hook on springs between shoes.
2. Locate one shoe in position.
3. Lift the other shoe into position.
4. Remove wire or other device used to retain pistons in cylinders and refit adjustment arrangements. The cam should be in its neutral position during refitting.
5. Adjust shoes to a position concentric with the drum. Fit springs holding shoes against backplate, if such springs are used.
6. Refit wheel hub.

Press the brake pedal hard to make sure that the shoes are centered in the drum before readjusting brakes whenever a drum has been removed.

## FRONT BRAKE SHOES, TYPE III

### DISASSEMBLY

1. Remove the piston-locking springs (7) that unite the brake piston with the brake shoe, first unhooking the spring off the piston.
2. Remove the steady pins (2) for the brake shoes.
3. Ease the heel of the rear shoe out of the wheel cylinder as illustrated and then move the shoe carefully outwards to disengage the backplate peg (3) from the adjuster lever groove so that the toe of the shoe can be removed from the piston. Use the fingers only and do not touch the pull-off spring. Also, take great care not to distort the pull-off springs and clicker catches.
4. Remove the upper shoe in the same way. Wind a piece of wire or some other suitable device round the cylinders to prevent the brake pistons from falling out.
5. Remove friction washers, spring and pin and then detach the adjuster lever from the brake shoe. An exchange system is operative for brake shoes: adjuster levers and friction washers are included, so that no attempt should be made to remove this parts.

## REPLACEMENT OF LININGS

An exchange system is operative for complete brake shoes with fitted automatic adjustment device. Replacement of linings thus calls for exchange of the entire shoe.

If linings only are replaced they should be ground in a special machine to a radius of 0.0047 in. (0.12 mm) less than that of the drum in order to ensure perfect contact. The ends of the linings must not be chamfered; the edge should be left as sharp as possible.

### WARNING

Do not allow oil or grease to come in contact with brake linings or drums.

### REASSEMBLY

1. Check the adjuster lever and friction washers for wear, if these items have been removed and then locate the adjuster lever in its groove in the brake shoe. Position the friction washers on either side of the adjuster lever and fit the spring, retaining pin and spring retainer. Note! Do not lubricate the friction washers.
2. Check the pull-off springs and, if necessary, adjust the clicker catches to the correct measure.
3. Push the adjuster levers over towards the shoe table as far as possible and refit both pull-off springs, taking great care to ensure that their clicker catches are correctly located in the friction washers — see fig.
4. Remove the wires used to retain the pistons.
5. Refit the upper brake shoe first, making sure that the backplate peg (3) engages with the oval hole in the adjuster lever.
6. Using the hands only, refit the lower shoe in the same manner, taking care not to touch the springs.

### NOTE

It is of the utmost importance that the clicker catches on the pull-off springs do not get distorted during assembly.

7. Refit the piston-locking springs, and locate the steady pins with retaining pins, and spring retainers for the brake shoes.
8. Centralize the shoes and refit the brake drums.
9. Adjust the front brakes by depressing the brake pedal firmly several times.

## REAR BRAKE SHOES, TYPE III

These are dismantled and reassembled in exactly the same way as rear shoes of type II.

## INSTALLATION OF BRAKE SHOES

1. Hook on springs between shoes.
2. Locate one shoe in position.
3. Lift the other shoe into position.





## HANDBRAKE

The handbrake is of mechanical type and acts on rear wheels only. Movement of the brake lever is transmitted by the handbrake cable to levers on the rear brakes, which mechanically expand the brake shoes against the drums.

### HANDBRAKE CABLES

The handbrake cables are permanently lubricated and comprise inner steel wires in plastic-coated spiral sheathing, led through a sleeve under the rear-seat back. At panels, cables are fitted with protective grommets. The cables are clamped to the rear axle and the inner wires are attached to the wheel-cylinder levers by clevis and pin connections. A return spring is fitted between the clevis and the spiral sheathings; while, in patt. I, another return spring is fitted between the wheel lever and a lug on the rear side of the brake backplate.

### REMOVAL

1. Remove one front seat and rear-seat cushions. Jack up rear of car.
2. Remove rear wheel.
3. Back off adjustment nut at bottom of handbrake lever.
4. Pull cable sheathing out of sleeve under rear seat.
5. Back off clamp screws fixing cable at rear axle.
6. Remove pin retaining clevis to cylinder lever.
7. Work grommet free from inclined panel in rear-axle tunnel.
8. Pull out entire brake cable to rear.

### INSTALLATION

1. Refit rear grommet on cable, if removed.
2. Pass cable, threaded rod first, up through diagonal panel in rear-axle tunnel, through sleeve under rear seat and then to handbrake lever. Check that grommet in front inclined panel is not displaced.
3. Fit adjusting nut.
4. Fit clevis to cylinder lever and secure pin.
5. Locate rear rubber grommet in panel in rear-axle tunnel and fix cable to rear axle with the two clamps.

#### NOTE

Check that spiral sheathing does not touch brake pipe.

6. Refit wheel and lower car to floor.
7. Refit cushions and adjust handbrake

### HANDBRAKE LEVER

See illustration of lever and component parts.

### REMOVAL

1. Push back front seats, removing one seat if required for better accessibility.
2. Remove rubber boot from handbrake lever.
3. Back off adjustment nuts.
4. Remove retainer (cotter pin) and pull out lever bearing pin from ratchet sector. Collect spacers
5. Remove lever.

### DISASSEMBLY

1. Remove cotter pin and pawl pivot pin.
2. Push pawl rod up towards handgrip.
3. Back off locknut; remove release button, locknut, spring and washer.
4. Remove pawl rod, pawl and washer at pawl.

### REASSEMBLY

1. Check that springs, pawl, ratchet and pivot pins are free of defects.
2. Refit pawl in lever. Release button should project about 3/8 in. (10 mm) beyond handgrip when pawl is engaged with ratchet.
3. Refit lever to ratchet, with spacers, pin and cotter pin (retainer).
4. Reconnect brake cables to lever.
5. Adjust handbrake

## ADJUSTMENTS, BLEEDING

### ADJUSTMENT OF FOOTBRAKE

Gradual decline in brake effect over a long period usually indicates wear of brake linings. When the pedal is depressed for normal braking it should not travel more than two-thirds of the distance between its normal position and the toeboard. for Types I and II

On types I and II there is an adjustment device for each wheel.

On type III, the front brakes are self-adjusting, and therefore an adjustment device is provided for the rear wheels only. This adjustment device is the same as for type II. For type III, it is essential always to keep the rear wheels well adjusted, so that pedal travel is kept at a minimum.





## ADJUSTMENT OF BRAKE SHOES

As seen from the illustrations, the adjustment for front brakes is identical in patterns I and II; but the adjustment for rear brakes differs between the two patterns. For patt. I it is similar in principle to that for the front brakes, but the adjustment for patt. II is located on the inside of the backplate and the screw head has wrench flats.

1. The car should be jacked up with all four wheels clear of the floor. Take care to locate hydraulic ram correctly. Brakes can normally be adjusted without removing wheels.
2. Release handbrake. Check that cylinder levers return fully. It may be necessary to press them back by hand if wire is stiff in sheathing.
3. Press hard on pedal to center brake shoes.
4. **Front wheels, types I and II**  
The two adjusting screws are accessible through a special adjusting hole in the brake drum after removal of the hub cap.

### Front wheels, type III

Self-adjusting, hence no adjusted device.

### Rear wheels, type I

The adjusting screw is accessible through one of the wheel-bolt holes.

### Rear wheels, types II and III

The adjusting screw is located externally on the rear of the backplate.

5. Turn the adjusting screw to the right with a screwdriver until the brake shoes lock the drum. Then loosen one or more turns until the wheel again rotates freely. Press the brake pedal to center the shoes and check that the adjustment is as close as possible. On rear brakes of types II and III the adjusting screw is turned with a spanner. Do not tighten the screw too hard.  
Repeat this procedure with each adjustment device.
6. Insert and tighten removed wheel bolts. Replace hub caps and lower car to floor.

## ADJUSTMENT OF BRAKE-PEDAL FREE MOVEMENT

As seen in fig., there should be a clearance between the master-cylinder piston and the push rod when the pedal is not depressed. This clearance ensures that the piston will return fully after release of the pedal. This clearance should amount to at least 0.031 in. (0.8 mm) in types I and II, and 0.024 in. (0.6 mm) in type III. This correspond to a free movement at the tip of the pedal of 0.2—0.4 in. (5—10 mm) and 0.12—0.24 in. (3—6 mm) respectively. Adjust as follows:

1. Turn back rubber mat.
2. Release left half of toeboard (l.h. drive car) or right half (r.h. drive car).

3. Stand the toeboard half against the side panel. Full removal would entail disconnecting dimmer switch.
4. Back off locknut,
5. Turn hexagonal part of push rod until free movement at pedal top is .2—4 in. (5—10 mm).
6. Tighten locknut.
7. Refit toeboard and rubber mat.

## ADJUSTMENT OF HANDBRAKE

Adjustment of handbrake-lever travel or of the brake cables may be necessary after a long period; always adjust foot brakes first and, if handbrake adjustment is still required, do this with adjusting nuts 1, which may be reached from the driver's seat.

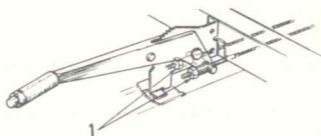

Handbrake lever and adjusting nuts

1. Jack up rear of car to bring wheels off floor.
2. Remove right seat and move handbrake lever to bottom position.
3. Tighten left adjusting nut until brake shoe presses against drum. Use a suitable hex socket wrench.
4. Back off nut again until wheel can be freely turned, then back off nut one more turn.
5. Repeat adjustment on right side.
6. Test action by pulling handbrake lever firmly and then returning it to floor. Wheels should turn freely when lever is pulled up two ratchet cogs but should be locked at the third.
7. Check that braking effect is similar on both wheels.

### NOTE

Always adjust brake shoes before adjusting handbrake.



## BRAKE FLUID

### GENERAL

Always keep the brake-fluid reservoir well filled. Check the level every 1,500 miles (2,500 km) or once a month, whichever occurs first.

It is essential to use the right brake fluid. Inferior brake fluids can seriously damage the entire brake system. Apart from ruining rubber seals and cups, such fluids may lack lubricating properties and initiate corrosion. Furthermore, they may be excessively viscous at low temperatures or have a low boiling point, leading to vaporization in the system at hard braking. This would result in brake failure, the consequences of which could be disastrous.

Even the best brake fluids deteriorate after prolonged use owing to oxidation and absorption of water, which lowers the boiling point. Bearing this in mind, always keep brake fluid in a sealed container. Always change brake fluid after any repairs to the brake system, every 40,000 miles (60,000 km) or once every three years.

### IMPORTANT

Use only brake fluid conforming to (minimum) specification SAE 70 R3, e. g. Lockheed Super Heavy Duty Brake Fluid.

### REPLENISHING

Before unscrew the filler cap, clean the top part of the reservoir to prevent dirt from entering when cap is removed. Be careful not to spill any brake fluid on the paintwork when topping up, as this fluid is injurious to paint. Check that the air vents in the filler cap are not choked. If brake-fluid consumption is abnormal, check all lines, connections and cylinders for leakage while applying firm pressure to the brake pedal.

### CHARGING SYSTEM WITH FLUID

If inferior-grade fluids have been introduced into the system for any reason, take the following steps without delay:

1. Drain the entire system.
2. Remove and disassemble master and wheel cylinders.
3. Flush system with methylated spirits.
4. Replace all rubber parts.
5. Reassemble and install cylinders.
6. Charge system with Lockheed Original or comparable brake fluid to correct specification.

### BLEEDING THE SYSTEM

After work involving removal of pipe or hose couplings, or if it is suspected that air has entered the system, it must be bled. Sure signs that air has entered the system are excessive pedal travel, a

springy pedal action or absence of brake effect until the pedal has been *pumped* several times.

Type I and II systems have a bleed nipple at each brake. In type I systems there is no bleed nipple for the right rear brake.

### NOTE

With brake systems of types I and II, the reduction valve will prevent fluid flow to rear wheels if the brake pedal is depressed to hard before the nipple is opened.

It is easier to bleed the system if the car is jacked up. Proceed as follows:

### Types I and II

1. Check that the reservoir is full and that air holes in cover are not choked.
2. Fit a suitable-sized hose over a brake bleed nipple,

If a wheel cylinder has been removed, begin at that brake. If the master cylinder has been removed, begin at the brake nearest the master cylinder. This permits air to escape by the shortest route.

3. Dip free end of bleed hose in a clean glass vessel containing a little brake fluid.
4. Back off nipple.
5. While an assistant pumps the brake pedal up and down, watch to see when escaping fluid is free of air bubbles. Allow the pedal to rest a few seconds at its upper position between strokes. Keep the hose end below the level of the fluid in the glass vessel the whole time.
6. Close bleed nipple during downward pedal movement, or when pedal is fully depressed, and remove hose.
7. Repeat bleed procedure at all brakes.
8. Check that all nipples are closed and recharge system with fluid. Never attempt to re-use dirty fluid.

### Type III

The procedure is the same as for type II with the following exceptions:

As the master cylinder has tandem pistons, it will be necessary to bleed both rear wheels, and resp. both front wheels simultaneously in order to purge the system. Begin with the rear wheels and bleed the front wheels afterwards.

1. Fit suitable hoses to the bleed nipples on both wheels.
2. Dip the hose ends in a glass jar containing clean brake fluid.
3. Loosen both nipples 1/2—1 turn.



4. Have an assistant pump the brake pedal — quickly down and slowly up — and watch until escaping brake fluid is free of air bubbles. Keep the hose ends submerged in the glass jar the whole time.
5. Close the bleed nipples, keeping pedal depressed meanwhile.
6. Check that the brake fluid in the reservoir does not run out while the system is being bled.
7. Top up the reservoir with fresh brake fluid after having bled rear and front brakes.

#### NOTE

Roughly in the middle of the pedal stroke, some springiness will be felt in the brake pedal on account of the two pressure-regulating valves in the two-circuit system. This is perfectly normal and should not be confused with the springiness caused by the presence of air in the system.

### BRAKE AND CLUTCH CONTROLS

The clutch and brake pedals are carried on a common shaft (see ill.) under the toeboard, which is pierced to accommodate the pedals. The shaft is borne in the two arms of a sheet-metal bracket. There is a return spring for the brake pedal. The entire assembly, referred to as the pedal frame, is secured by five bolts: two to the floor pan and three to the cowl plate these latter also retaining the brake master cylinder. Movement of the clutch pedal is transmitted to the clutch linkage lever (under the transmission case) by the clutch cable, a spring on the lever returning the pedal on release. The cable comprises and inner steel wire in a steel housing, and a rubber bushing protects it from wear against the floor pan. The housing, or outer wire, is attached to the cowl plate passed through a lead pulley and connected to a link rod by means of an adjustment screw and a common attachment. The link rod is attached to the clutch linkage lever at its other end. The inner wire of the clutch cable is tensioned between the clutch pedal and a lug under the engine. Adjustment of the screw on the outer wire increases or reduces clutch pedal movement.

Movement of the brake pedal is transmitted to the master cylinder by a push rod, with a hinged attachment to the pedal. The push rod consists of two parts, joined by a threaded connection with locknut, which permits adjustment of rod length. To adjust movement of the brake pedal, the locknut is backed off and the inner part of the push rod screwed in or out, as necessary.

### ACCELERATOR, STARTER AND FREEWHEEL CONTROLS

#### STARTER CONTROL

To chassis No. 1120 (Saab 95) & 112499 (Saab 96). The starter control, located on the right below the instrument panel, is of pull type and consists of a T-shaped grip attached to a Bowden cable. The outer wire of the Bowden cable is attached to the lever while the inner wire is anchored to the engine compartment floor pan in front of the starter motor. On cars after chassis No. 1121 and 112500, resp., the starter motor is provided with a solenoid, connected to the ignition key.

#### COLD-START CONTROL

The cold-start control, also of pull type, consists of a Bowden cable between a button on the left of the instrument panel and the carburetor cold-start device.

Apart from the neutral position, the control may be set to two different positions, corresponding to different carburetor mixtures, as described in Chapter. 6, Fuel System. The richest mixture is obtained at the outer position, from which the control returns automatically.

#### ACCELERATOR CONTROL

The accelerator control comprises a lever and a bent shaft, joined by a ball-jointed link rod. The bent shaft is carried at its rear end in a bracket on the radiator support member, and at its front end is connected via a rubber bellows to a plate on the carburetor throttle spindle. A return spring is attached to an arm on the shaft and anchored to the wheel-house panel.

The lever is carried in bearings on the front of the dash panel and its rearward-pointing end passes through a rubber seal in the panel, being fitted at its extremity with a roller and a guide moving in a guideway on the underside of the accelerator pedal.

#### FREEWHEEL CONTROL

The freewheel control consists of a pull rod fitted at one end with a handgrip (located on the left, above the accelerator pedal). The rod passes through a rubber seal at the cowl plate and is, at its other end, connected to the freewheel operating lever on the upper side of the gear box casing.

The handbrake linkage is described in Brakes.

**BRAKE AND CLUTCH PEDALS****REMOVAL**

Each pedal may be removed separately, if the pedal shaft is dismounted. However, in order to facilitate the operation the entire pedal frame ought to be dismounted.

1. Remove rubber mat and back off screws retaining toeboard.
2. Lift away both halves of toeboard. The left half (l.h.-drive car) may be stood against inner panel; if it is to be removed from the car, cables must be disconnected.
3. Slacken clutch cable by a screwing in adjustment screw at front end of cable (i.e. increase pedal play).
4. Disconnect inner cable from fork at clutch pedal (fork is slit at one side for removal of cable).
5. Disconnect brake pedal from master cylinder by backing off locknut, and unscrew main-cylinder push rod (hex head is visible outside rubber bellows).  
Brake pedal may also be disconnected from cylinder by releasing push rod from rubber bellows; the rod will then accompany the pedal frame when this is lifted away.
6. Remove bolts fixing pedal frame to floor and cowl plate. The three cowl plate bolts also hold the master cylinder. Nuts are accessible from the engine compartment.

**INSTALLATION**

1. Locate pedal frame. If master-cylinder push rod has not been removed with frame, pass rod into master cylinder and work rubber bellows over it.
2. Fix pedal frame and master cylinder with the three bolts on front of master cylinder flange.
3. Fit both bolts securing pedal frame to floor pan. Insert these bolts from underside of pan.
4. If master-cylinder push rod was disconnected from fork at brake pedal, reconnect rod to fork. Note here that brake-pedal free movement must be adjusted before locknut is tightened. Correct movement at pedal tip is for model 1960-63 0.20-0.40 in. (5-10 mm), and for model 1964 0.12-0.24 in. (3-6 mm).
5. Tension clutch cable by screwing out adjustment screw, adjusting clutch-pedal free movement to 3/4-1 in. (20-25 mm), measured at top of pedal.
6. Replace both parts of toeboard and fit fixing screws. If cables have been disconnected, reconnect these before replacing left half of toeboard.
7. Refit rubber mat.

**LUBRICATION**

Lubricate clutch and brake-pedal bearings with oil, also push-rod bearing pin in brake pedal. Oil holes are provided at the right of each pedal arm, as illustrated.

**CLUTCH CABLE****REMOVAL**

The cable may be removed without disturbing the pedal frame.

1. Screw in adjusting screw sufficiently to permit release of cable from lug under engine.
2. Disconnect adjusting screw, attachment and link rod from clutch cable.
3. Remove toeboard on pedal side.
4. Back off nut outer cable attachment to cowl plate and remove washer.
5. Remove outer cable attachment (slit on one side).
6. Release inner cable from fork connection to clutch pedal. Fork is slit on side to permit removal of cable.
7. Draw out clutch cable forwards.
8. Collect nut and lockwasher for outer cable attachment.

**INSTALLATION**

1. Pass in cable from front, through hole in cowl plate. From other side of panel, fit lock washer and nut on cable.
2. Connect inner cable to fork on clutch pedal.
3. Refit outer-cable attachment with lockwasher and nut.
4. Reconnect adjusting screw to link-rod attachment.
5. Refit link rod to attachment.
6. Pass front end of clutch cable into adjusting screw and lead inner cable to lug on underside of engine. Do not omit to refit rubber bushing on cable.
7. Check location of link rod in clutch linkage lever.
8. Unscrew adjusting screw sufficiently to secure correct clutch pedal movement, i.e. 3/4-1 in. (20-25 mm).
9. Refit toeboard and rubber mat.

**Clutch cable**

1. Adjusting screw
2. Outer wire attachment at cowl plate
3. Lead pulley

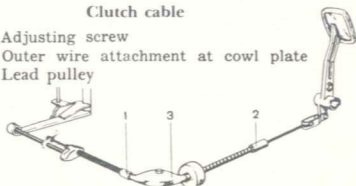





## ADJUSTMENT OF CLUTCH-PEDAL FREE MOVEMENT

Free movement of the clutch pedal, measured at its top, should be 3/4—1 in. (20—25 mm). Wear of the clutch facings reduces this movement, but it must not become less than 3/8 in. (10 mm). Adjust the movement by means of the adjustment screw (see fig.) on the clutch cable. The screw is readily accessible on the left side of the engine compartment. Turning to the right (i.e. screwing in) increases pedal free movement.

## ACCELERATOR

### REMOVAL

1. Separate accelerator pedal from lever roller and remove roller from lever.  
If pedal is to be removed from car, back off both bolts under rubber mat, securing pedal bracket to floor pan.
2. Unhook return spring
3. Disconnect ball-joint link from shaft.
4. Remove cardboard sheet from behind radiator and back off screws fixing lever bearings; collect leaf spring.
5. Release rubber seal from dash panel and remove lever and seal, in a forwards direction.
6. Remove rubber seal from lever.
7. Drive out cotter pin at shaft bearing, in bracket on radiator support member.
8. Work rubber bellows free from plate on carburetor throttle spindle.
9. Pull shaft forwards out of its bearings, and collect plain washer, nylon bushing and spring.

### INSTALLATION

Replace worn or damaged parts.

1. Refit shaft, together with nylon bushing, spring, plain washer and cotter pin, to bracket on radiator support member.
2. Work rubber seal onto lever and pass lever through dash panel from front. Do not omit to refit leaf spring.
3. Reconnect ball-joint link to lever and shaft.
4. Refit rubber bellows to shaft and throttle spindle.
5. Connect return spring to shaft.
6. Refit rubber roller on lever and locate it in guide on pedal underside.
7. Check that depression of accelerator pedal gives full motion of throttle spindle.

## CHECKING AND ADJUSTMENT

The distance between the accelerator pedal and the toeboard should be 2 in. (50 mm). It may be adjusted by means of the ball-joint link. This link consists of a rod with ball joints threaded on both ends and secured by nuts. Increase link length to raise the accelerator pedal.

If the lever has become deformed, adjustment of link length may not be sufficient to achieve correct pedal adjustment. The lever must then be realigned. Be careful during this operation not to strain the lever bearing. Make a final adjustment with the ball-joint link.

A leaf spring between the lever and the dash panel prevents rattle from the bearing. The nylon bushing in the shaft bearing, in the bracket on the radiator support member, may easily be replaced if worn. Simply remove the cotter pin. Lubricate the accelerator-linkage bearings and ball joints with oil.

## STARTER CONTROL

### GENERAL

All Saab 95 and 96 cars from chassis No. 1121 and 112500, resp., have a solenoid switch on the starter motor connected to the ignition key, instead of the control described here, which thus refers only to earlier cars.

### REMOVAL

#### NOTE

The inner wire may be replaced without disconnecting the outer wire.

1. Release Bowden-cable inner wire from front anchorage and pull it out of the outer wire.
2. Release outer wire connection to starter lever.
3. Back off nut securing wire under instrument panel.
4. Pull out wire to rear and collect nut.
5. Remove starter handle from old wire.

### INSTALLATION

1. Grease inner wire to ensure free movement in outer wire. Push cable through attachment on instrument panel, pass nut and washer onto cable, and then push it through seal in dash panel.
2. Tighten nut.
3. Reconnect outer wire to starter lever.
4. Reconnect inner wire to front anchorage.
5. Fit starter handle.

**COLD-START CONTROL DESCRIPTION****REMOVAL**

1. Disconnect Bowden cable from carburetor.
2. Back off nut behind instrument panel.
3. Pull out cable to rear, collecting nut and washer.

**INSTALLATION**

Grease inner wire to ensure free movement in outer wire.

1. Push cable through instrument panel, pass nut and washer onto cable and push cable through seal in dash panel.
2. Tighten nut behind instrument panel.
3. Reconnect outer wire to its attachment on carburetor cold-start device.
4. Reconnect inner wire to operating member on carburetor cold-start device. See that the control button on the instrument panel is pushed right in when the operating member is at its neutral position.

**IMPORTANT**

If the cold-start device does not return fully to the neutral position, fuel consumption will increase considerably.

**NOTE**

Check the return spring at the carburetor and adjust it so that the control button springs back from the outer to the intermediate position as soon as it is released.

**FREEWHEEL CONTROL****REMOVAL**

1. Disconnect pull rod from freewheel operating lever by removing cotter pin and washer.
2. Unscrew handgrip and remove rod forwards, or release rubber seal from dash panel and pull both rod and seal out backwards.

**INSTALLATION**

1. Refit rubber seal on pull rod and pass rod through dash panel.
2. Inspect rubber bushing on operating lever.
3. Reconnect pull rod to operating lever by means of cotter pin and washer.
4. Press rubber seal in place in dash panel.
5. Fit handgrip to rod.

**WHEELS**

The dished wheels and wide-base rims, both of pressed sheet steel, are riveted together to form an integral unit.

The rim is pierced (1) for the tire valve, while there are five pressed holes (2) in the wheel to accommodate the wheel bolts. The wheel is also fitted with three buttons (3) to retain the hub cap, and four gaps in its circumference, against the rim, permit application of snow chains. Finally, there are twelve cooling and lightening holes in the wheel.

**HUBS**

The wheel hubs are shaped to form an annular seal against the brake backplate. This prevents the entry of water, sand, etc., into hub and brakes. Front wheel hubs are also provided with cooling flanges. In both and rear hubs there are five threaded holes for wheel bolts and a rim which centers the wheel when fitted.

**TIRES**

Tubeless tires are sized 5.00×15" (Saab 96) or 5.60×15" (Saab 95); while the speed tires with separate tubes, as fitted to the GT 750, are sized 155×15".

Tires usually carry balancing marks, either a round colored mark or one or more triangles, on the tire wall. See fig. A round mark indicates the lowest grade of accuracy, while the number of triangular marks indicate increasing grades of accuracy in the balancing of the tire. The marks are applied on the lighter side of the tire and should be located at the valve when the tire is fitted. The illustration below shows how the corrugated wall and bead of the tubeless tire seal against the rim flange (bead seat).

**CHANGING WHEELS****REMOVAL**

1. Apply handbrake and take out spare wheel.
2. Remove hub cap.
3. Loosen wheel bolts.
4. Jack up car — see Chapter 1, general.
5. Remove wheel bolts and wheel.

**INSTALLATION**

1. Rest wheel on hub rim and turn until wheel-bolt holes are in line. When fitting front wheels see that brake-adjustment hole is correctly placed.
2. Steady wheel at bottom with one hand until two lowest bolts are fitted.
3. Fit remaining bolts; do not tighten finally as yet, but turn each bolt a couple of times in the sequence shown below. Torque to 58—72 ft-lb. (8—10 kgm.). Bolts should not be tightened finally until car is lowered to floor.

# 14 WHEELS AND TIRES



4. Refit hub cap. This is easiest done by resting inside of hub-cap flange over two of the buttons and knocking cap onto third button by hand.

## ADJUSTMENT AND REPAIR OF WHEELS

Damage to wheels can occur in collisions or if the car leaves the road, or through driving on a flat tire. Tubeless tires seal against the rim and will not retain air if the rim is deformed or otherwise damaged.

If air leakage occurs due to a deformed rim, remove the tire and inspect the wheel, adjusting as required. Any rust inside the rim flange should be removed with a steelwire brush or steel wool. If the rust has corroded into the rim, use a file. Any minor pitting remaining after rust removal should be coated with a thick solution, which is also applied to the bead of the tire, and the tire fitted before the solution dries.

Check that the rim is free from run-out and not buckled. If it is, adjust these faults, Badly deformed or damaged rims must be replaced. Inspect the rim for cracks, which could allow air leakage. Minor cracks can be welded, but it is important that welds in the rim flange be carefully cleaned and filed flush to ensure a close tire fit. Note that the rim must not be soldered under any circumstances.

Check that no rivets are loose. Loose rivets may be re-secured with a hollowing (double-ball) hammer, a holding-up tool being applied at rivet's underside. A few drops of quick-drying solution applied under rivet heads further improves the closure. Never try to weld leaky rivets.

After straightening the rim, check that out-of-round and run-out are within tolerable limits. When a correctly fitted wheel is rotated, the difference between highest and lowest points, measured at must not exceed 0.1 in. (2.5 mm.).

Run-out is similarly measured and should not exceed 0.1 in. (2.5 mm.), either.

When checking these tolerances, the wheel should be normally fitted either on a hub or on a special rig permitting free rotation of the wheel.

## TIRE AND WHEEL INTERCHANGE

Front-wheel drive causes greater wear on front tires than on rear. Tires should therefore be changed round after a longer mileage, to bring the least-worn tires at the front. The tires should always be fitted to rotate in the same direction as before, a left rear wheel being interchanged with a left front wheel. If tires are regularly interchanged, wear will be approximately equally distributed.

## TIRE PRESSURES

A basic requirement for long tire life is the maintenance of correct pressures. Check tire pressures every week.

A. When pressure is correct, the entire tread is in contact with the road, giving good grip and even wear.

B. If pressure is too low, the tire will be pressed down and wear will be greater at the sides. Tire walls are subject to abnormal flexing and may crack. Cord breakage, which is difficult to repair, may be caused, and furthermore, cord plies and tread may be separated. Low pressure also increases roll tendencies when cornering.

C. Excessive tire pressure results in greater transmission of road shocks and causes the tire to "swell", so that only the tread center is in contact with the road. Wear is hereby accelerated and the tread will easily crack, especially at the bottom of the longitudinal grooves of the tread pattern, with consequent risk of blow-outs.

## WHEEL BALANCING

Wheels must be statically and dynamically balanced to avoid vibrations (shimmy) and consequent excessive wear.

Correct static balance implies that the wheel when freely fitted on a hub, will remain in any position without rotating due to its own weight.

Static balance is achieved by fitting the wheel on a spindle carried in a low-friction bearing, or rolling on horizontal rails. All parts must be well-cleaned and the tire correctly inflated.

A dynamically balanced wheel will run at all speeds in a plane exactly at right-angles to the rotation axis, i.e. it will not tend to be thrown out of line.

Special equipment is required for full wheel balancing. Some types of equipment balance wheels separately, others balance them while fitted. If the latter type is used, be careful when balancing front wheels to apply the jack under the ball joint next to the wheel, to ensure horizontal location of the drive shaft. Lock the opposite wheel.

New wheels should not be balanced until after 600—900 miles (1,000—1,500 kilometers), giving the tires an opportunity to accommodate themselves to the rim.

Wheels should be rebalanced after a long mileage, since tire wear will affect weight distribution.



## DESCRIPTION

### GENERAL

The electrical system works on 12 volts and comprises the following: battery, starter, generator, voltage regulator, ignition distributor and coil, spark plugs, lighting and directional indicators, windshield wipers, fan motor, horn, stop-light switch, and cable harnesses with wiring, switches and fuses.

### BATTERY

The 12-volt lead battery has 6 cells and a capacity of 34 amp.hours. It is placed on a support to the right of the radiator. The ground lead is connected to body and power unit.

### GENERATOR

The generator is connected to a voltage regulator, and delivers — when the voltage regulator is of the type RS/TBA 160/12/1 — a maximum power of 240 watts. If the voltage regulator is of the type RS/VA 200/12/A2 the maximum power will be 300 watts. Whether the generator is charging the battery correctly or not, is shown: by an ammeter in the Saab 95 and Saab 96, model 1960—1963, and by a warning lamp in the model 1964 and the GT 750.

### STARTER

The starter motor, rated for 1/2 h.p., is engaged by a starter lever or, on later cars, by a solenoid switch actuated by the ignition key.

### IGNITION SYSTEM

The engine is equipped with coil ignition, comprising battery, ignition coil and a centrifugally- or vacuum-governed distributor. The system is controlled by the ignition key switch.

### LIGHTING

The road lights comprise headlamps, directional signals parking lights, license lamp, tail lights and directional signals/stop lights.

The headlamps may be easily adjusted for vertical and lateral settings. They are switched on and off by a pull switch on the instrument panel, which also controls the parking lights and has three positions: off, parking lights on, all lights on. A foot dimmer switch is provided for the headlamps, a warning lamp on the instrument panel indicating when headlamps are on full (upper) beam.

### MISCELLANEOUS ELECTRICAL EQUIPMENT

Courtesy light consists of a roof lamp operated by a switch at the lamp and by door switches.

An automatically-returning switch on the steering column controls the directional-signal flashers, a green warning lamp on the instrument panel indicating when these are switched on.

The dual-tone horns, operated by a button in the hub of the steering wheel, comprise harmonised high and low notes.

The windshield wipers are driven by one motor via a dual linkage and are controlled by an instrument-panel switch. This switch also serves to actuate the windshield washer, which is of mechanical type on the Saab 95 and 96 and of electrical type on the GT 750.

### WIRING AND FUSES

The various leads from battery and generator to the points of current consumption are collected in harnesses, arranged according to groups. Individual wires are color-marked to simplify identification.

Terminals are formed by non-soldered AMP connectors.

To protect wiring, etc., from abnormal current strengths (due to short circuits, for example) and thus reduce fire risk, fuses are incorporated. These are grouped on a fuse board at the right side of the engine compartment, on the cowl plate. Two extra fuse points are provided for subsequent accessories. The fuses are dimensioned for a continuous current of 8 amp.

## BATTERY

### GENERAL

The battery is a 12-volt lead unit with 6 cells, the working voltage per cell being about 2 volts. The electrolyte is dilute sulphuric acid of s.g. 1.280 at 68° F (+20° C) when the battery is fully charged. The capacity of the battery is 34 ampère-hours (Ah), indicating that it can supply a 1.7-amp. current for 20 hours, at a temperature of 68° F (20° C). The positive terminal of the battery is connected to the starter and other consumer points, while the negative terminal is connected to ground (i.e. the body).

### REMOVAL AND INSTALLATION

When removing the battery from the car first disconnect the negative terminal, to prevent short-circuit and then the positive terminal.

Next back off the two retaining wing nuts. The battery may be lifted clear.

Before installing, check that the battery is clean externally; check especially that posts and cable terminals are clean, so that there will be good contact. After installation, coat the posts and terminals with acid-free vaseline.





## BATTERY MAINTENANCE

The condition of the battery determines the ease of starting and it is therefore important that it is tested and serviced regularly. Failure to do this will result in difficulties, in particular during cold weather, when starting loads are higher and battery capacity is reduced by the low temperature. A poorly charged battery is liable to freeze.

### ELECTROLYTE LEVEL

Due to evaporation and decomposition of the electrolyte water the level in the battery will tend to fall. Refill until the level is approx. 3/8 in. (10 mm.) above the plates, using only distilled water.

Add sulphuric acid if the battery has been emptied or has leaked. The specific gravity must always be checked after acid has been added.

### S.G. OF ELECTROLYTE

The s.g. of the electrolyte may be checked with a hydrometer of syringe type, the result being an indication of the remaining capacity in the battery; see table below.

Charging condition	S.g. of electrolyte
Fully charged	approx. 1.28
Half charged	approx. 1.21
Discharged	approx. 1.12

### CELL VOLTAGE

A more accurate test of the battery condition is made by using a battery voltmeter, comprising a low-reading voltmeter and parallel-connected resistance giving a load of 80—100 amp.

Test each cell individually by placing the voltmeter points against the cell terminals.

The indicated voltage should not be less than 1.6 volts after 10—15 sec. discharge (e.g. by running the starter). If the voltage falls lower, the cell has inferior capacity or is otherwise faulty.

The normal initial cell voltage (undischarged) is 2 volts, and the variation in voltage between any two cells should not exceed .2 volt.

### CHARGING

The charging rate must be suited to the battery capacity and should not exceed 2.5 amp. in the case of a 34 Ah battery.

The battery is fully charged when cell voltage has remained at 2.5—2.7 volts without load during the last three hours of charging.

## GENERAL

During driving the generator supplies the current required for all the consumer equipment plus enough to charge the battery. A voltage regulator is fitted to keep the generator voltage approximately constant, regardless of generator r.p.m. and load, and prevent overcharging of the battery. The voltage regulator also ensures that the generator will not be connected to the battery until adequate speed (and thus voltage) has been reached. The voltage regulator breaks the connection again if the generator speed drops below a certain rate and thus prevents discharging of the battery through the generator.

The generator pulley is finned to induce a current of cooling air over the generator when running. The air enters through openings in the commutator end frame and is drawn out through openings in the drive end frame. The water pump is connected direct to the generator shaft — see COOLING SYSTEM, Chapter 8.

## REMOVAL AND INSTALLATION OF GENERATOR

Remove the generator and water pump assembly as follows:

1. Disconnect battery negative terminal.
2. Drain cooling system.
3. Disconnect generator cables, fixing and adjusting bolts and remove fan belt.
4. Disconnect hoses from water pump and lift out generator.
5. Install in reverse sequence.
6. Adjust fan-belt tension so that the belt can be depressed 1/4—5/16 in. (6—8 mm.) by finger pressure.

Beginning with the year model 1964, the generator has rubber suspension, which decreases the vibrations in the suspension components. This means that the generator bracket and the muffler's upper attachment are of a new design. The retaining screws of the generator bracket have been equipped with rubber bushings.

In case of rupture in the generator suspension in cars older than those mentioned above, these should be equipped with a rubber suspension.

There are two types of generator brackets with holes suited for rubber suspension: one with short attachment-ears, intended for older cars with downward outlet for the water pump, and another with long attachment-ears intended for later cars with upward outlet for the water pump.



## GENERATOR AND VOLTAGE REGULATOR

### DISASSEMBLY AND REASSEMBLY

1. Remove end cover of water pump by backing off four nuts.
2. Unscrew impeller and then remove pump body.
3. Remove generator belt pulley.
4. Remove commutator cover band and remove carbon brushes from holders.
5. Back off two through bolts and carefully tap drive end frame (11), releasing this together with attached armature.
6. Release commutator end frame (7) by backing off contact screw at hub.
7. Disconnect both terminals and remove intermediate and coil housings.
8. Back off two screws at hub of drive end frame to release this from armature.
9. Drive off ball bearings from armature and commutator end frame.
10. Clean all parts carefully with white spirit and blow with compressed air, except for armature winding and field coils, which should be blown with compressed air only.
11. Check all parts for wear, replacing as necessary. Ball bearings should show only the slightest play and should work silently after cleaning and air blowing. When installing, pack bearings with special Bosch grease, FT1v22.
12. Reassemble in reverse sequence. Check that all terminals are well secured and that spring washers are fitted on screws and bolts.  
The armature should have a slight longitudinal play to relieve the ball bearings of side loads.

### MAINTENANCE AND INSPECTION OF GENERATOR AND VOLTAGE REGULATOR

#### CARBON BRUSHES

Check generator brushes and commutator after about 18,000 miles (30,000 km.) as follows:

1. First disconnect battery negative cable, then disconnect cables connected to DF and D+.
2. Remove cover band from commutator end.

#### IMPORTANT

Always disconnect cables before removing cover band.

3. Hook back brush springs as illustrated, and check that brushes slide freely in holders.
4. If a brush does not slide freely, remove it and wipe both brush and holder with a cloth moistened with white spirit. Do not rub brush contact surfaces.

5. Refit brush in exactly same position as before, to ensure same relation to commutator.
6. If a brush is so worn or damaged that the spring rests against its stop, replace brush. Always use genuine Bosch brushes.
7. When installing brushes be careful to prevent springs striking hard against brushes, since these may be damaged thereby.
8. Replace cover band, being careful to avoid contact with terminals DF and D+.
9. Reconnect cables to DF and D+. Do not confuse cables. Reconnect battery negative cable.

#### COMMUTATOR

The commutator should present a dark gray, smooth contact surface to the brushes, absolutely free from oil or grease. Clean a dirty commutator with a cloth moistened with white spirit, and dry carefully afterwards. A commutator which has become scored or oval through wear must be turned, undercut and sanded by a specialist shop. Never use emery paper or a file on a commutator.

Only slightly dirty commutators may be sanded without removing the generator from the car by pressing a suitably shaped piece of pumice against the commutator while the generator is turned.

#### TESTING THE CHARGING CIRCUIT

The generator and voltage regulator can be comparatively simply checked and tested with a suitable voltmeter/ammeter, which combines a 0—20-volt moving-coil voltmeter with a 10—0—25 amp. moving-coil ammeter. The most important checks, and the first to be made when a fault is suspected, are testing of the generator no-load voltage setting as per B, below and the load voltage setting, as per C. If the results are not satisfactory replace the voltage regulator or generator, or send them to a specialized shop for overhaul.

The values in brackets refer to voltage regulator RS/VA 200/12/A2, and the values without brackets to voltage regulator RS/TBA 160/12/1.

- A. Easiest way to check the voltage regulator's closing voltage is to connect the voltmeter to the minus terminal and terminal D+ on the regulator. Allow the engine to idle and switch on the parking lights to give a suitable load. Increase engine r.p.m. very gradually, watching the voltmeter all the while. At the instant of closing the voltmeter reading will drop slightly, and then resume its increase as r.p.m. continues to rise. The voltage immediately prior to this drop is the closing voltage and should be between 12.4—13.1 volts (12.3—13.3).



**B.** To test **no-load voltage setting** disconnect the cable from terminal B+ on the voltage regulator, taking care not to let it touch other metal parts, which would short-circuit the battery. Preferably, disconnect the battery negative cable during disconnection of the B+ lead. Connect a voltmeter between ground and B+ on the regulator and increase engine r.p.m. until the generator is turning at 5,000 r.p.m. Note the voltmeter reading; it should be 14.3—15.3 (13.8—14.8) volts at an ambient temperature of 68° F (+20° C).

#### WARNING

Do not let the disconnected cable touch metal parts — short-circuiting will result.

#### NOTE

Do not allow the test to take longer than half a minute, as the quoted values apply only to a cold voltage regulator.

**C.** To test **load voltage setting** most simply, switch on headlights at full beam, windshield wipers and heater fan at maximum speed to provide a load. Connect the voltmeter between ground and B+ on the regulator (cable connected). Increase engine speed gradually until the generator r.p.m. is about 5,000, and read the voltmeter. It should indicate 13.5—14.5 (13.3—14.3) volts. As to the RS/VA-regulator, as a rule only the following method is applicable, when a higher load is required than that obtainable with the car's standard equipment. If the car is equipped with two auxiliary lights, switch same on together with the equipment mentioned before. In this way the test load required is obtained.

A more exact method of applying a load is to connect an ammeter and a resistance in series between ground and B+ on the regulator, instead of switching on the equipment mentioned above. In this case, the cable at B+ must be disconnected and suitably protected from contact with metal parts, to prevent short-circuit. Adjust the resistance to secure

a current strength of 15 (25) amp. at 5,000 r.p.m. generator speed. Connect the voltmeter as described above, **between** B+ and ground, and note the reading at the quoted r.p.m. It should be 13.5—14.5 (13.3—14.3) volts.

#### NOTE

Do not allow the test to take longer than half a minute, as the quoted values apply only to a cold voltage regulator.

**D.** To test the voltage regulator **cut-out relay** for discharge current, disconnect cable at B+ and introduce an ammeter between B+ and the cable end. Increase engine speed to turn the generator at more than 1,900 r.p.m., the approximate closing rate, and then reduce speed slowly to idling; during this the ammeter needle will move from CHARGE through zero to DISCHARGE. The discharge current setting of the cut-out relay is the maximum ammeter minus reading, and should be 3—9 (2.0—7.5) amp.

**E.** If no voltage is indicated in tests A, B or C, the generator may be defective and should be inspected separately.

To test the generator separately disconnect all leads and introduce a voltmeter directly between D+ and D— terminals. Connect DF to ground. With the generator running at not more than 1,900 r.p.m. the voltmeter should indicate 12 volts.

To check whether the generator is delivering current, also connect an ammeter in series with an adjustable resistance (at about 1 ohm) between D+ and D— and increase engine speed to give a generator rate of not more than 2,600 r.p.m. Adjust voltage to 12 volts. The ammeter should read not less than 13.3 amp.

## STARTER

### GENERAL

The starter is an electric motor which, through a pinion and a ring gear, turns the engine flywheel for starting. The starter pinion can slide on the armature shaft and is drawn into mesh with the ring gear by an operating solenoid, which subsequently actuates a switch and closes the circuit to the starter motor. As soon as the engine fires the pinion will be driven by the flywheel ring gear. The pinion is then disengaged from the armature shaft by a freewheel device, but remains in mesh with the ring gear as long as the ignition key is held and activates the operating solenoid. When the key is released and the current to the solenoid is broken, the pinion is returned by a spring. On the earlier pattern of starter the pinion was engaged by a starter pull-control and lever linkage.

### REMOVAL

1. Disconnect battery negative cable.
2. Disconnect cables to starter and, on earlier type, starter control.





3. Back off nuts on two bolts fixing starter to lower part of crankcase. Use a short, open-ended 1/2-in. wrench with two identical ends at 15° and 60° angles to handle, resp.
4. Pull back starter until clear for lifting out of engine compartment.

#### INSTALLATION

1. Pass starter into position and tighten fixing nuts.
2. Reconnect cables and, on earlier type, attach starter-control outer wire to lever and inner wire to lug at floor of engine compartment.
3. Reconnect battery negative cable.

#### DISASSEMBLY AND REASSEMBLY OF STARTER, PULL CONTROL TYPE

##### DISASSEMBLY

1. Remove brush cover band.
2. Back off through bolts 26.
3. Remove pinion housing. Note number and sequence of washers 16, which must be replaced in same arrangement.
4. Take tension off brush springs and pull out armature. Collect washers 20 and 21.
5. Back off field winding connections and other fixing screws in commutator end frame.
6. Remove commutator bearing 29.

##### CLEANING

1. Wash all parts except pinion in white spirit, carefully removing all foreign matters. Be careful to protect bearing bushings 12 and 31 from white spirit and other grease solvents.
2. Check that brushes are in perfect order and move freely in holders.

##### REASSEMBLY

1. Lubricate bearing bushings with a suitable mineral oil.
2. Pass in armature and fit correct number of washers 20 and 21 on shaft. Note that insulation washer 21 must be located between washers 20.
3. Locate commutator bearing 29 and insert bolts 26. Check that locating tongue is fitted in recess.
4. Fit pinion 13 and washers 16 on shaft, checking that same number of washers is fitted as was removed.
5. Fit lever clevis 18 in pinion groove and locate pinion housing.
6. Tighten through bolts.
7. Reconnect field windings to brushes.
8. Refit cover band with screw downwards to permit free runoff for any water which might seep in.

#### WARNING

Be careful to avoid short-circuits between the cover band and brush leads or terminals.

#### DISASSEMBLY AND REASSEMBLY OF STARTER, SOLENOID TYPE

##### DISASSEMBLY

1. Remove cover band.
2. Hook of brush springs.
3. If commutator end frame is to be removed, disconnect brush and coil leads.
4. Disconnect operating solenoid from pinion housing by removing three retaining screws and jumper strip from solenoid. Remove solenoid upwards and outwards.
5. Remove operating solenoid fork by pulling out pivot pin.
6. Back off and remove through bolts holding together starter assy.
7. Divide assembly at pinion housing and remove armature together with pinion on armature shaft. Collect brake washers from commutator end, and adjustment washers at pinion.
8. Remove pinion from armature shaft by pressing in the locating collar with a sleeve arbor and then picking out the spring from within the locating ring.
9. Blow the parts clean with compressed air and wash in white spirit, except bearing bushings, starter pinion and coils, which must be protected from all grease solvents.

##### REASSEMBLY

Replace any damaged or worn parts and then reassemble as follows:

1. Fit starter pinion on armature shaft and secure with spring and locating ring. Lubricate pinion, shaft and locating collar with special Bosch grease.
2. Insert adjusting washers in pinion housing, locate solenoid fork and fit armature and pinion assy. in pinion housing.
3. Fit fork pivot pin.
4. Fit armature brake washers at commutator, placing insulating washer between the two steel washers. Lubricate washers with special Bosch grease.
5. If commutator end frame has been removed, replace this. Reconnect brush bushings and field-coil terminals.
6. Lubricate bearing bushings sparingly with oil. Reassemble armature and pinion housing with starter housing and commutator end frame. Insert and tighten through bolts.





### NOTE

The armature should have a longitudinal clearance of .004—.012 in. (0.1—0.3 mm.), adjusted by means of shims at pinion housing. If new bearing bushings are to be fitted, soak them in warm oil for 1 hour prior to assembly.

- Refit operating solenoid and connect jumper strip to terminal screw.
- Refit brushes and cover band.

### WARNING

Be careful to avoid short-circuits between the cover band and brush leads or terminals.

## MAINTENANCE AND INSPECTION OF STARTER

### CARBON BRUSHES AND COMMUTATOR

- Remove cover band and check that brushes move freely in holders. If not, clean both brushes and holders with a cloth moistened with white spirit. Do not rub brush contact surfaces.
- Defective or worn brushes, as also weak or distorted springs, must be replaced.
- If commutator is oily or dirty, wash it clean with a cloth moistened with white spirit. Keep spirit away from bearing bushings and wipe all traces from commutator after cleaning. If commutator is scored or oval then it must be removed from armature and sent to a specialized shop for turning, undercutting and sanding. Never use emery paper or a file on a commutator.

### OPERATING SOLENOID

The operating solenoid has two windings, a powerful attraction winding and a weaker holder winding. If the latter is defective, the solenoid will repeatedly engage and disengage when starting is attempted. The solenoid must then be replaced. Check all connections very carefully, as poor connections will prevent starting.

The distance between the fork engaging pin and the solenoid retaining flange,  $A$ , must agree with the table below when the core is fully withdrawn.

Type of starter	Distance A in in. (mm.)
C:DD 0,5/12 R 8	1.04 (26.5 ± 0.1)
AL, EDD 0,5/12 R 4	1.14 (29.0 ± 0.1)

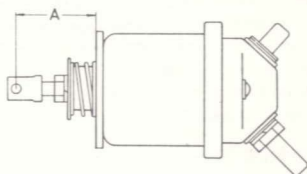

Adjustment of operating solenoid  
Core pulled in entirely

## IGNITION SYSTEM

### DISTRIBUTOR GENERAL

The following types of distributor appear:

Bosch designation	Ignition governor	For
VJ3 BR7T	Centrifugal	Saab GT 750
VJ3 BR8T	Centrifugal	Saab 95 up to chassis No. 4836 Saab 96 up to chassis No. 148268
VJU3 BR 2T	Vacuum + centrifugal	Saab 95 from chassis No. 10.801 Saab 96 from chassis No. 201.401

The differences between the distributors is that they have varying governors. VJU3, which is a vacuum distributor, is connected to a vacuum take-off on the carburetor. When setting the ignition with a stroboscope the vacuum regulator must be disconnected by removing the vacuum hose from the distributor. When reconnecting make sure that the hose is drawn in a coil around the fan bearing bracket. This is to prevent oil from the fuel running down into the vacuum tank and setting the governor out of operation. On distributor VJU3 BR2T there is a new ventilation system, see below.

### REMOVAL

- Disconnect the battery ground strap and the low-tension cable.
- Remove the distributor cap and, if vacuum regulated, disconnect the hose at the vacuum tank.
- Slacken the lock screw 9 (see illustration) on the anchorage plate under the distributor. If the distributor is a VJU3 BR1T or a VJU3 BR2T, the generator stay at the generator must also be disconnected and lifted up.
- Pull the distributor out of the engine.
- Disconnect the ignition cables from the cap.

### INSTALLATION

- Remove the spark plugs and turn the crankshaft so that the marking on the pulley coincides with the centre marking on the engine block (If there are only two markings, use the upper).

**2a Distributors VJ3 BR7T and VJ3 BR8T**

Fit the distributor into the engine so that the lubricator faces forward and the markings on the rotor and the housing coincide.

**2b Distributor VJU3 BR1T and VJU3 BR2T**

Fit the distributor so that the vacuum tank faces rearwards with about 10—15 mm free play to the engine block. The markings on the rotor and housing must coincide simultaneously.

Screw fast the generator stay and tension the fan belt.

3. Connect the low-tension cable and battery ground strap.
4. Put on the distributor cap. The ignition cable for the 2nd cylinder is fitted in the socket opposite the rotor, when the marking on the pulley coincides with the centre, or subsequently the upper, marking on the block. Then fit, clockwise, the ignitions cables for the 3rd and 1st cylinders.
5. Set the ignition (see "Timing") and, subsequently, connect the hose to the vacuum tank.

**IMPORTANT**

When installing the distributor

- a) The marking on the pulley shall coincide with the centre (or upper) marking on the engine block.
- b) The markings on the rotor and housing shall coincide
- c) Distributors VJ3 BR7T and VJ3 BR8T are installed with the lubricator facing forwards, distributor VJU3 BR1T and VJU3 BR2T is installed with the vacuum tank rearwards.

**IGNITION SYSTEM****Positive ventilation**

In distributor VJU3 BR2T a new ventilation system has been introduced. This system means that the overpressure of the forced draft generated when you are driving is used for pressing fresh air through the distributor; the overpressure of the air prevents water and dirt from entering the distributor. Water and impurities cannot, now, enter the distributor through the vent hose, as the latter now goes from the fresh air collection chamber. The outlet of the hose is equipped with a splash hood, as protection against sprinkles of water when driving in the rain.

The vent hose is, connected to the top of the distributor cap, which has a special recess for this purpose.

**IMPORTANT**

Essential for good operation is that nowhere the hose hangs down too low but has fall towards the distributor, thereby preventing the hose from being folded up.

Check that the vent holes in the bottom of the distributor are not clogged by dirt.

**DISASSEMBLY OF DISTRIBUTORS VJ3 BR7T AND VJ3 BR8T**

Clean the distributor thoroughly before commencing disassembly.

1. Remove the rotor 3. It is secured to the breaker cam with the stop screw 5, see the illustration.
2. Lift off the protective cover 2 from the breaker mechanism.
3. Slacken the nut 11 for the capacitor cable.
4. Remove the circlip 6, and lift up the breaker arm 7. The bracket goes with the breaker arm when this is being lifted up. Then remove the screw for the breaker-arm spring, and collect washers, fibre washers and the contact strip for the low-tension connection.  
For BR7T the lock screw for the bracket with the stationary point must also be loosened.
5. Remove the screw 8 with the contact washer, insulating washer and insulating strip 9. Take care of the insulating washers 10.
6. Remove the three screws 29, which hold the breaker plate 13 into place. Two of these screws also hold the retaining springs 32.
7. Collect the retainer springs and lift up the breaker plate 13.
8. File off and drive out the slotted pin 26, which holds the distributor gear 28 to the shaft 22. Take care not to damage the shaft.
9. Lift out the distributor shaft with the automatic ignition governor. Take care of the washers 24 and 25 and the shims 27, if fitted.
10. Unhook both of the weight springs 17 from the spring anchorage 23 and lift off the breaker cam 16. Take care of the spacer washers 14 and fibre washer 15.
11. Unhook the springs from the cam. Bend down the spring anchorages, carefully, if necessary.
12. Release the circlips 31 and lift off the governor weights 18 and 19. Take care of the fibre washers 20 under the weights.
13. Remove the fibre plate.  
Note the screws 33 under the distributor shaft plate. By loosening these screws the spring anchorage 23 can be turned for the adjustment of the governor spring tension. This tension is correctly set initially, and should not be altered.
14. Remove the capacitor 30 from the cap.
15. Remove the O-ring from the housing.
16. Press or drive out the bushings from the distributor housing if they are worn and need replacing. Remove the lubricating felt from between the bushings first.



## REASSEMBLY OF DISTRIBUTORS VJ3 BR7T AND VJ3 BR8T

Before assembly all parts shall be washed and inspected, all worn or damaged parts must be replaced.

1. If necessary, drive new bushings in the distributor housing and fit the lubricating felt between the bushings.
2. Screw the capacitor to the housing.
3. Fit a new O-ring.
4. Place the fibre plate 23 onto the distributor shaft steel plate. The fibre plate shall be situated so that the oblong hole comes over the round hole in the steel plate.
5. Put the fibre washers 20 on the governor weight pivots and grease the pivots. Note that grease should be applied sparingly to all bearings and sliding surfaces in the distributor. Regarding lubricant, see the chapter "Lubrication and Service".
6. Put the smallest governor weight 19 onto the pivot nearest to the hole in the steel plate. On BR7T the governor weights are of equal size, and their relative location does not matter. Note that the glide projections of the governor weights shall face downwards towards the fibre plate.
7. Fit the other governor weight and lock the weights with the circlips 30.
8. Hook on the governor springs 17 to the anchorages on the cam 16 and bend the anchorages so that the springs cannot come loose during continued assembly.
9. Put the cam onto the shaft after it is initially greased. Make sure that the pins on the bottom of the cam get into the grooves of the weights.
10. Hook the governor springs onto the outer spring anchorages 23.
11. Make sure that the governor functions satisfactorily by turning the breaker cam clockwise.
12. Put the spacer washer 24 and then the fibre washer 25 onto the shaft.
13. Grease the shaft and slide it into the housing.
14. Fit the breaker plate 13.
15. Put the breaker plate into the housing and anchor with the screw 29.

## REPLACEMENT OF BREAKER POINTS AND ADJUSTMENT OF GAP DISTRIBUTORS VJ3 BR7T AND VJ3 BR8T

This operation can be carried out with the distributor in the car but is greatly simplified if the unit is removed.

1. Release and remove the cap.

2. Remove the rotor, see the illustration, which is secured at the breaker camshaft with a stop screw.
3. Take out the protective cover.
4. Loosen the nuts on the screw for the low-tension cable.
5. Remove the spring on the shaft and lift off the breaker arm.  
BR7T: Loosen also the lock screw for the stationary point bracket, which goes with the breaker arm when same is being lifted up.  
Note and collect the spacer washers for the adjustment of the breaker arm axial play.
6. Unscrew the screw 11 and remove the stationary point bracket.  
BR7T: Loosen the screw for the breaker-arm spring to the stationary point bracket, then collect washers, fibre washers and the contact strip to the low-tension connection.
7. Fit a new stationary point.  
BR7T: Fit breaker arm, contact strip with appertaining washers onto the stationary point bracket; tighten the nut slightly, then fit the stationary point bracket with breaker arm and contact strip to the contact-breaker plate. Before final tightening of the lock screw for the contact plate, and of the nut for breaker arm spring, depress the breaker arm fully, checking at the same time for good contact of the breaker points. If required, adjust by placing spacer washers at the breaker arm bearing.
8. Fit a new breaker arm, using the requisite number of spacer washers, see the illustration, at the breaker arm bearing and secure with the lock spring.
9. Make sure that the breaker arm is correctly fitted, see the illustration, and tighten the nuts for the capacitor and low-tension cables.
10. Adjust the point gap, with the eccentric screw. On the BR7T this is made by inserting a screwdriver into a groove in the stationary point bracket. The correct gap is 0.3—0.4 mm.  
If a dwell testing apparatus is used the readings shall be as follows:  
Distributor VJ3 BR8T ..... 77°—83°  
Distributor VJ3 BR7T ..... 80°—84°
11. Put the protective cover over the breaker arm mechanism.  
Rub a little grease Fl v 4 on the edge of the cover, so that it seals effectively against the housing cap.
12. Refit the rotor.
13. Check the ignition setting. See "Ignition setting".
14. Clean and inspect the distributor cap, ignition cables, spark plugs and cable terminal caps at the distributor and ignition coil.
15. Put on the distributor cap.





#### **DISASSEMBLY OF DISTRIBUTOR VJU3 BRIT**

1. Unscrew the stop screw 6 and remove the rotor 4.
2. Lift off the protective cover 8.
3. Loosen the nut 36 for the capacitor cable and remove the washers, connector, insulating washers and the screw 27.
4. Take off the circlip 13, push out the leaf spring and lift up the breaker arm. Note. Take care of the spacer washers on the breaker arm pivot.
5. Loosen the screw 22 and take off the pivot 24.
6. Remove the vacuum tank with the appertaining spacer by unscrewing the screws 55.
7. Loosen the screws 30 and 39 for the plate 9, which also secures the anchorages for the retainer springs 31 and 40.
8. Take care of the retainer springs and lift up the plate.
9. Loosen the screw 19 and remove the bearing 21.
10. Lift the moving breaker plate 16 from the stationary plate.
11. File off and drive out the slotted rivet 74 which secures the gear 78 to the shaft 68. Take care not to damage the shaft.
12. Lift out the shaft together with the automatic ignition governor. Take care of the washers 75, 77 and, if fitted, the shims 76.
13. Unhook both of the springs 69 from the spring anchorage 70 and lift off the cam 61. Take care of the spacer washers 59 and the fibre washer 58.
14. Unhook the springs from the cam.
15. Remove the circlips 62, 63 and lift off the governor weights 64 and 65. Take care of the fibre washers 66 under the weights.
16. Remove the fiberplate 67.  
Note the screws 73 under the distributor shaft plate. By loosening these the spring anchorage 70 can be turned for the adjustment of the governor spring tension. This tension is set initially, and should not be altered.
17. Remove the capacitor 47 from the distributor housing.
18. Remove the O-ring from the housing.
19. If necessary, should they be worn and require replacing, press or drive out the bushings from the housing. First of all remove the lubricating felt from between the bushings.

#### **ASSEMBLY OF DISTRIBUTOR VJU3 BRIT**

1. Press on, if necessary, the new bushings. Do not forget the lubricating felt between the bushings.
2. Screw on the capacitor.
3. Fit a new O-ring.
4. Put the fibre plate 67 onto the distributor shaft steel plate. Fit the fibre plate so that the oval hole comes over the round hole in the steel plate.
5. Place the fibre washers 66 on the governor weight pivots and grease the pivots. Note that all bearings and sliding surfaces should be greased sparingly. Regarding lubrication see the chapter entitled "Lubrication and service".

6. Place the smaller of the two governor weights 64 on the pivot which is nearest to the hole in the steel plate. Note that the governor weights must be fitted with their projections turned down towards the fibre plate.
7. Fit the other governor weight, and secure with the circlips 62 and 63.
8. Install the governor springs 69 at the anchorages on the breaker cam 61.
9. Place the breaker cam on the shaft after greasing the shaft. Make sure that the pins on the underside of the cam fit into the governor weight grooves.
10. Hook the governor springs to the outer spring anchorages 70.
11. Check that the governor functions properly by rotating the breaker cam clockwise.
12. Put the spacer washers 75 and then the fibre washer 77 on the distributor shaft.
13. Grease the shaft and slide it into the distributor housing.
14. Grease the glide surfaces and install the moving breaker plate on the plate.
15. Install the bearing 21 with the screw 19. Before tightening the screw, push down the support, so that sufficient tension is obtained on the breaker plate.
16. Place the plate 9 in the distributor housing so that the pin for the breaker arm is on the opposite side to the recess for the low-tension cable.
17. Fit the two retainer springs 31 and 40 tighten the two screws 30 and 39 which secure the plate and the spring anchorages.
18. Grease the pin and install the breaker arm. Adjust the axial play, and height position in relationship with the contact, with spacer washers and then secure with the circlip.

#### **NOTE**

The retainer spring anchorage, which is integral with the tongue for the distributor cap, shall be placed at the marking on the housing, see the illustration.

19. Fit the screw 27 for the low-tension connection with fibre washers, steel washers and the connection, and connect the cables from the breaker arm and the capacitor.
20. Check the setting of the vacuum tank's control arm, and fit the vacuum tank with the appertaining spacer onto the distributor housing.
21. Connect the vacuum tank pull rod to the breaker plate with the pivot 24 and the screw 22. Do not forget to connect the vacuum tank ground strap to the screw.
22. Fit the gear to the distributor shaft.  
Adjust the axial play of the distributor shaft, before fitting the gear, with shims (76). The permitted axial play is 0.1—0.2 mm (0.004—0.008 in.). Take care when driving in and riveting the slotted pin so that the shaft, bearing nor gear are damaged. Note that the slotted pin must be riveted carefully. The rivet head height may not exceed 0.5 mm 0.02 in.)





23. Adjust the gap between the points, by loosening the retainer screw and regulating the point gap with the eccentric screw, or on later models by putting a screwdriver between a pair of projections on the breaker plate and the corresponding groove in the retainer. The gap shall be between 0.3 and 0.4 mm (0.012—0.016 in.). If a dwell angle tester is used the dwell angle should be  $77^{\circ}$ — $83^{\circ}$ .
24. Put on the protective cover and fit the rotor. On VJU3 BR2T is the condensation shield (protective cover) equipped with a rubber sealing. To make the condensation shield fit, it must be placed so, that the arrow points to the mark on the distributor housing.

### IMPORTANT

It is important that the spring washer under the stop screw must be replaced with a new to prevent the screw from loosening.

### REPLACEMENT OF BREAKER POINTS AND ADJUSTMENT OF GAP, VJU3 BR1T

The operation can be carried out with the distributor in the car but it is greatly simplified if the distributor is removed.

1. Release and remove the cap.
2. Remove the rotor which is anchored to the breaker camshaft with a stop screw.
3. Take off the protective cover.
4. Loosen the nut for the low-tension cable connection for the breaker arm.
5. Remove the circlip and push the leaf spring out of its anchorage. Lift up the breaker arm and take care of the spacer washers.
6. Remove the screw 5 and loosen screw 7 a few turns. Lift up the contact retainer together with the stationary breaker contact. NB. There is an eccentric screw on earlier models. Make sure that this screw does not fall down into the distributor.
7. Install a new stationary contact.
8. Install a new breaker arm after greasing the pivot. Adjust the axial play, and the height position in relationship to the breaker contact, and secure with the circlip.
9. Make sure that the breaker arm spring slides into its anchorage and then connect the cable to the low-tension connection and tighten the nut.
10. Adjust the gap with the eccentric screw on earlier models and by putting a screwdriver between a pair of projections on the breaker plate and the corresponding groove on the contact retainer. The gap shall be between 0.012—0.016 in. (0.3—0.4 mm) If the gap shall be adjusted with the aid of a dwell angle tester the dwell angle shall be  $77^{\circ}$ — $83^{\circ}$ .

### NOTE

The spring washer must always be replaced with a new one to prevent the breaker rotor lock screw from loosening.

11. Put the protective cover back over the breaker arm mechanism.
12. Screw on the rotor.
13. Check the ignition setting. See "Ignition setting".
14. Clean and inspect the cap, ignition cables, plugs and rubber caps at the distributor and ignition coil.
15. Put on the cap.

### IGNITION ADVANCE

Ignition advance is regulated by a centrifugal governor or else by a centrifugal governor in combination with a vacuum governor. The advance can be checked in a distributor tester with the aid of the curves on the preceding page. Centrifugal and vacuum regulation are checked separately. Whether or not the vacuum regulation is operating can be checked in the car as follows. When the ignition has been set with the aid of a stroboscope keep the engine speed running at about 3000 r.p.m. When the vacuum hose has been reconnected at the distributor the advance position should move a further  $10^{\circ}$  from the original advance, which is about the same as 11 mm on the pulley.

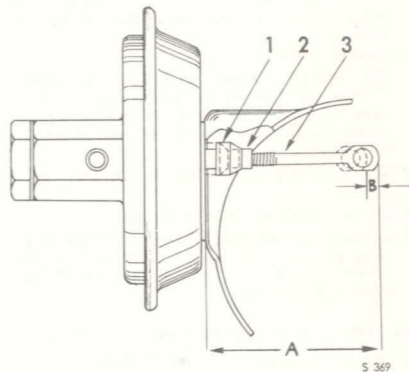

### Vacuum control. Checking length of control arm.







When adjusting, hold fast nut 1, and loosen nut 2. Then screw the control arm in or out resp., until obtaining proper length. Then lock control arm with lock nut

Measure A =  $1.69 \pm 0.008$  in. ( $42.8 \pm 0.2$  mm)

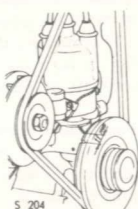
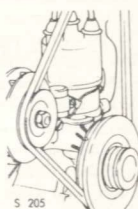
B = Stroke  $0.137 \pm 0.006$  in. ( $3.5 \pm 0.15$  mm)

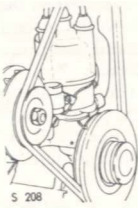

**IGNITION VALUES**

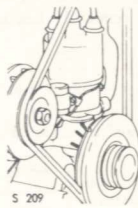
Distributor Bosch designation	VJ3 BR7T	VJ3 BR8T	1. VJU3 BR1T 2. VJU3 BR2T
Model	Saab GT 750	Saab 95 up to chassis No. 4836 Saab 96 up to chassis No. 148268	1. Saab 95 from chassis No. 4837 2. Saab 95 from chassis No. 10801  1. Saab 96 from chassis No. 148269 2. Saab 96 from chassis No. 201401
Ignition advance	centrifugal reg.	centrifugal reg	centrifugal and vacuum reg.
Breaker gap	0.3—0.4 mm	0.3—0.4 mm	0.3—0.4 mm
Dwell angle	80°—84°	77°—83°	77°—83°
Basic setting of ignition with aid of test lamp stationary engine  Ignition position in degrees on crankshaft B.T.D.C.	 S 203 2° (see note*)	 S 204 10°	 S 205 7°
Stroboscope setting at 3.000 r.p.m. approx  Ignition position in degrees on crankshaft B.T.D.C.	 S 206 22° (see note**)	 S 206 20°	 S 207 17° NB with disconnected vacuum hose
Check that the mark on the pulley tallies  The 2nd cylinder shall be at T.D.C.	 S 208	 S 208	 S 209

The following applies for GT 750 if equipped with double carburetors and special exhaust system:

\* Basic setting = 0° (upper setting mark)

\*\*Stroboscope setting = 20° (22 mm below the upper setting mark)



## IGNITION SETTING GENERAL

The order of firing is 1, 2, 3, when 1 is the rear cylinder.

Ignition setting is always carried out on the 2nd cylinder (the centre cylinder). The ignition position should always be checked and adjusted with the aid of a stroboscope at an engine speed of about 3000 r.p.m. This is a safer and better method than making the adjustment with a testing lamp, with a stationary engine.

At the front end of the engine there is a mark on the pulley and three (perhaps 2) on the engine block, as follows:

- When the mark on the pulley coincides with the upper mark on the engine block the second piston shall be at top dead centre. The upper mark is to ascertain that the mark on the pulley is in the correct position, or for remarking the pulley is in the correct position, or for remarking the pulley when the crankshaft or pulley have been replaced.
- When the mark on the pulley coincides with the centre mark on the block it shows the setting of the ignition of a stationary engine with a test lamp and when installing the distributor. This mark only appears on late production cars. In the case of early production cars the ignition position can be evaluated with the aid of the values given in the table.
- When the mark on the pulley is opposite the lower mark on the block, this shows the ignition position for the 2nd cylinder at an engine speed of about 3000 r.p.m. and is used when setting the ignition with the aid of a stroboscope. Note that the engine speed shall be within the limits shown after the first step on the regulation curve. See "Ignition advance".

If the engine is equipped with a vacuum distributor the hose to the vacuum tank shall always be removed when setting the ignition.

The positions of the setting marks in relationship to top dead centre for the 2nd piston can be obtained from the table below.

Degrees on crankshaft	Distance on pulley from upper setting mark, e.g. T.D.C. for 2nd piston. Pulley diameter 126 mm
0	—
2	2.2 mm
7	8 mm
10	11 mm
17	19 mm
20	22 mm
22	24 mm

## IGNITION SETTING WITH A STROBOSCOPE

- Check the breaker points and arms and adjust to the correct gap. When installing a new rotor always fit a new spring washer so that the screw is effectively locked. Inspect and clean the cap, ignition coil, ignition cables, spark plugs and the terminals at the plugs and distributor cap.
- Turn over the crankshaft until the mark on the pulley coincides with the centre mark on the engine block (the upper mark if there are only two).
- Fit the distributor so that the marking on the rotor is opposite the mark on the edge of the distributor housing and the lubricator points forwards or the vacuum tank rearwards in the case of VJU3 BRIT.
- Connect the stroboscope to the 2nd cylinder ignition cable and start the engine. Increase the engine speed gradually. A clear alteration of the advance will be noted between 1000 and 2000 r.p.m. When the engine speed is increased further it will become constant. The ignition is set within this range by loosening the lock screw and turning the distributor housing. When the mark on the pulley coincides with the lower mark on the engine block, lock the distributor with the lock screw.

### NOTE

In the case of VJU3 BRIT the vacuum hose shall be disconnected during ignition setting.

## SETTING THE IGNITION WITH A TEST LAMP

If a stroboscope is not available the setting of the ignition can be carried out with a test lamp connected between the casting and the low-tension cable.

- Remove the distributor cap, rotor and protective cover. Inspect the points and adjust the gap.
- Refit the protective cover and rotor. Use a new spring washer to ensure that the screw is properly locked.
- Turn over the crankshaft so that the mark on the pulley coincides with the centre mark on the engine block. If there are only two marks on the block turn the crankshaft to the value shown in the table.
- Fit the distributor so that the marking on the rotor comes opposite the marking on the edge of the distributor housing and with the lubricator facing forwards or, in the case of VJU3 BRIT, with the vacuum tank facing rearwards.
- Connect a test lamp between the casting and the connection for the low tension cable and turn on the ignition.
- Find the position in which the test lamp lights by turning the distributor housing slightly. Check





that the governor weights are in the inner position by turning the rotor anticlockwise. Secure the distributor with the lock screw.

7. Check that the setting is correct by turning the crankshaft one turn clockwise. When the marking on the pulley once more comes before the centre marking on the block, or to the value given in the table, the lamp should light. When in this position check that the marking on the rotor and that on the edge of housing coincide and that the governor weights are in the inner position.
8. Turn off the ignition and remove the test lamp. Clean and inspect the distributor cap, ignition cables, spark plugs and the terminals at the plugs and cap.

#### INSPECTING AND MARKING THE IGNITION SETTING MARK ON THE PULLEY

##### IMPORTANT

If the crankshaft or pulley have been replaced the marking on the pulley does not tally.

1. Fit an indicator gauge (tools 784040, 784060 and 784062) into the spark plug for the 2nd cylinder.
2. Turn the crankshaft until the piston is at top dead centre, which can be determined with the aid of the gauge.
3. The mark on the pulley will then coincide with the upper mark on the engine block. See the table. If this is not the case the old mark must be filed off and a new mark made with the file.

#### DISTRIBUTOR CAP

The distributor cap is furnished with breather holes, one at the front and one at the back. A protective cover is situated under the rotor to shield the space under the cap from condensation. It is imperative that the protective cover seals effectively both against the distributor housing and cap. Sealing is obtained by coating both sides of the edges of the cover with a little heat resistant grease such as, for example, Bosch Ft 1 v 4. There are no breather holes nor protective cover on older distributors. If shorts are to be avoided it is advisable to fit both the cap with breather holes and the protective cover.

##### IMPORTANT

If a distributor cap without breather holes is installed together with a protective cover, corrosion will occur followed by the resultant breakdown.

#### IGNITION COIL WITH IGNITION SWITCH

##### REMOVAL UP TO MODEL 1963

In connection with the introduction of a locking device for the reverse gear shift position has — beginning with the 1964 year model — the ignition switch been moved from the instrument panel to a bracket on the steering column stand.

At the same time, the ignition coil's armoured cable has been replaced by an ordinary cable, and the coil has been moved from the cowl plate to the wheel housing. This has made it possible to shorten the distributor's ignition cable.

1. Disconnect the negative cable from the battery and the cables at the coil.
2. Remove the air heating unit. When the screws are loosened bend the casing forward, it is thus unnecessary to disconnect the hoses. Note that the hood lock must be in the closed position, i.e. to the left.
3. Unscrew the ignition coil fixing screws and disconnect the cables at the ignition switch.
4. Disconnect the armoured cable rubber seal at the cowl plating.
5. Take out the ignition coil and switch, and remove the lock cylinder.

##### FITTING UP TO MODEL 1963

1. Put a new rubber seal on the cable. The operation is facilitated if a cone, about 150 mm long and 35—40 mm wide, made of metal sheet is manufactured and put in front of the switch. The cone has the purpose of extending the seal so that it goes more easily over the switch. See Chapter 20.
2. Put the new ignition switch into the hole in the cowl member. Regarding replacement of the lock cylinder, see "Replacement of lock cylinder in ignition switch".
3. Press the seal firmly into the cowl plating.
4. Screw in the ignition coil so that the low-tension cable terminal comes to the right.
5. Connect the cables to the ignition switch and fit it to the instrument panel so that the armoured cable comes underneath.
6. Fit the air heating unit, with the hood lock in the closed position. Prior to this it can be suitable to coat the rubber seal around the high tension cable with sealing solution.
7. Connect the cables to the coil and reconnect the battery negative cable.





### NOTE

A high-effect ignition coil is fitted to the GT 750. This coil must have a pre-connection resistor connected in the low-tension cable.

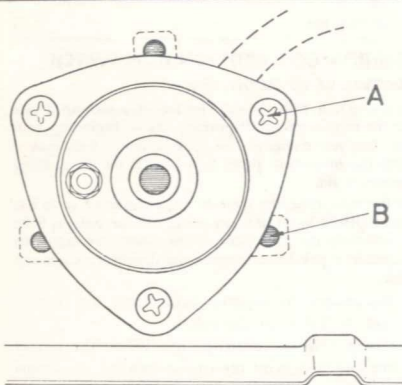

### FITTING THE IGNITION COIL IN EARLY PRODUCTION GT 750

The ignition coil is replaced in early production GT 750 as follows (see illustration):

- A. Drill three new holes and screw on the ignition coil with plastic screws No. 14.
  - B. Plug the three old holes.
- This is necessary owing to the fact that the original ignition coil is no longer stocked and the new type has a modified anchorage.

### REPLACING THE LOCK CYLINDER IN THE IGNITION COIL (UP TO AND INCLUDING MODEL 1963. FOR THE 1964 MODEL SEE CHAPTER 11).

If the ignition key has been lost, the lock cylinder can be replaced. Before removing the switch from the instrument panel drill a 9 mm hole in the centre of the switch to a depth of about 10 mm. Remove the switch and continue at point 4 below.

If the key is available the operation is carried out in the following way:

1. Release nut and remove the washer which holds the switch to the instrument panel.
2. Disconnect the battery negative cable and the cables at the switch.
3. Put in the ignition key and turn on.
4. Insert a picker or the like and press against the retainer, which is accessible through the hole in the threaded flange. If the retainer cannot be depressed easily in the "on" position, turn the key a little further clockwise until the correct position is reached to release the lock.

5. Pull out the lock cylinder and inspect the groove for the bakelite washer inside the lock housing. Make sure that the slot for the lock plate is not deformed and that the bakelite washer springs out sufficiently to give a firm grip.
6. Push in the retainer on the new lock cylinder, this is only possible in a certain position. Turn the key until the position is attained.
7. Check that the relative positions of the lock cylinder retainer, the locating tongue and plate agree with the recess in the lock housing and bakelite washer respectively. If the recess in the bakelite washer another position then the "on" position it must be turned with a screwdriver. When it is in the correct position it will spring back when turned further clockwise.
8. Keep the retainer pin depressed and push the lock cylinder into the housing, so that the locating tongue enters the groove. If the retainer does not coincide with its hole, the lock may, under no circumstances whatsoever, be forced down into the casing. Instead turn the key clockwise slightly whilst keeping it depressed. Push a thin driver through the square hole in the underside of the casing and brake the bakelite washer whilst returning the key slowly to the "on" position. The bakelite washer groove will then coincide with the lock plate, and the lock cylinder can be pushed in completely and the retainer will fit into its hole.
9. When the switch operates satisfactorily the cables are reconnected, and the switch is fitted into the instrument panel with the armoured cable underneath. Reconnect the battery negative cable.

### MAINTENANCE

It is important that the ignition system operates efficiently and regular attention should be given to prevent faults.

### SPARK PLUGS

Always fit plugs with the right temperature grading. Engine damage, such as seized pistons, can occur if faulty plugs are fitted. The following recommendations regard Bosch spark plugs.

Saab 95, 96	Extremely hard driving	M 240 T1
"	Normal driving	M 225 T1
Saab GT 750	Easy driving	M 240 T1
"	Hard driving	M 270 T16



Check the spark gap at regular intervals, about every 4,000 to 6,000 km.

Saab 95 from chassis No. 4010 and Saab 96 from chassis No. 143700 are fitted with resistance cables, which means that the spark gap must be 0.9 mm. In the case of early production vehicles, not fitted with resistance cables, it shall be 0.7 mm.

An excessively large gap gives rise to the risk of sparking in the distributor cap and at the ignition coil with the resultant damage. Usually the plugs should be changed every 10,000 to 15,000 km, dependent on the way which the car is driven.

#### SHIELDED IGNITION CABLES

Shielded ignition cables, also called resistance ignition cables, are used in the ignition system for radio- and TV interference elimination. They consist of a core of graphite-impregnated, plastic wire in an insulating covering. These resistance ignition cables have been fitted in cars from chassis No. 3001 for the Saab 95 and No. 135001 for the Saab 96. The total resistance in these ignition cables, i. e. from ignition coil to distributor and to spark plugs, must lie within the following values:  
maximum 35,000—40,000 ohms minimum 8,000 ohms.

#### DISTRIBUTOR AND IGNITION COIL

It is important that the high-tension parts of the ignition system such as the bakelite section of the ignition coil, the spark plug insulators and the ignition cables are kept free of dirt and dust. Especially must the distributor cap be wiped clean both internally and externally to prevent flash-over and breakdown. Remove all deposits from contact surfaces.

Check that the centre brush in the distributor cap has not stuck, and that the breather holes are open.

#### IMPORTANT

Wipe the distributor cap and other high-tension parts clean every 6,000 km.

When the ignition is checked and adjusted the lubricating felt under the distributor rotor should be greased.

Make a habit of checking that the ignition cables are properly inserted in their retainers in the distributor cap and ignition coil., thus avoiding unnecessary damage.

## DIRECTIONAL SIGNALS

### GENERAL

Directional signals are fitted at both front and rear and are controlled by a self-returning lever switch at the steering wheel, through a flasher relay. A warning light on the instrument panel indicates that the signals are operating.

If one of the signals fails to operate, the warning lamp will not light at all and the remaining lamp will flash more rapidly.

Normal frequency is 60—120 flashes/minute when the signals are in good condition and the correct bulbs are fitted.

Adjustment of the flasher relay is not possible. If all other parts seem correct (i.e. switch, leads and bulbs), then erratic behaviour of the signals must be due to a faulty relay, which should therefore be replaced.

for installation and return mechanism for directional indicator switch.

#### NOTE

The fitting of bulbs with incorrect ratings will result in abnormal flashing frequency.

### WINDSHIELD WIPERS

The wipers are driven by a motor located on the dash panel in the engine compartment, through a two-part mechanical linkage. The links are adjustable in length to permit setting of the correct blade sweep angle.

The motor is provided with a device to ensure that it always stops at the same position after switching off. This parking device is located on the motor adjacent to the connection terminals. If either of the leads connected to the wiper parker unit is broken or in poor contact the wipers will not stop at all, or will stop in intermediate positions. This also results if dirt penetrates between the breaker points of the parker unit.

#### NOTE

Check especially carefully that the ground connection through the right-hand retaining screw is satisfactory.



## OPERATION

The motor is fed with current from the battery through the ignition contact via fuse and switch, and direct from the fuse retainer via a breaker device, located in the motor. The latter is part of a device, which ensures that the wiper blades always stop at the same position.

When the ignition and the switch are on, the motor starts, making the rotor (1) rotate and actuate a cog wheel (2) with the aid of a gear. The wiper blades are operated from one of the cog wheel's pivots. During the continued rotation of the cog wheel (2), the cam (3) will raise the pivot (4) to the effect that the contact spring (5) is lifted off the contact (6), which has a direct connection to the battery via (53a), cable (14) through fuse and ignition contact. Then the contact spring is pressed against the contact (7), which is connected to (31b), which via cable (16), switch and cable (19) is grounded when the switch is switched off.

When the switch is on, nothing happens, as the contact spring (5) changes from the contact (6) to the contact (7), the feeding being made via (53) and the ground contact (31b) interrupted at the switch. When the switch is switched off, the motor stops immediately, if the contact spring (5) comes into contact with the contact (7), i. e. when the cam (3) is in a position where it can influence the contact spring (5). This happens once, for an instant, during each rotation of the cog wheel (2).

In any other position of the cam (3) — and in consequence that of the wipers — the rotation will continue until the contact spring (5) changes from (6) to (7) after switching off the switch, because the motor is fed also from (53a). That feeding is not made via the switch. When the contacts (5) and (6) switch off, the feeding of the motor is interrupted simultaneously with a short-circuit in the rotor cables through the contacts (5) and (7) via the switch, in which way the rotation speed of the rotor is rapidly decreased.

This is necessary to enable the motor to stop while the cam (3) influences the contact spring (5). Otherwise,

the motor would continue rotation, despite of the switch being switched off, especially when the wipers run smoothly and the tension is high through the motor, (when charging and when the current consumption is small).

The contact gap (between No. 5 and 7) shall be approx. 0.02 in. (approx. 0.5 mm) when the cam (3) does not influence the contact spring (5).

The contact gap (between the contacts 5 and 6) shall be approx. 0.04 in. (approx. 1 mm) when the cam (3) is in its highest position.

## TROUBLE SHOOTING

### Trouble, and its cause

Wipers do not start.

Wipers stop anywhere, when the switch is being switched off.

Wipers do not stop.

### Remedy

Inspect the fuse and the cable connections at switch and motor, and the ground cable (18) at the motor.

Inspect cable connections (14) at fuse and (53a). Clean contacts (5) and (6). Check that off and on is regular when the motor is running.

Check that the contact spring (5) breaks at (6) and closes at (7), and that when closing the contact is good between (5) and (7).

Inspect connections (31b) of motor and switch, and the ground cable (19) and its connection (31) and to the instrument panel.

"IMPORTANT": check also, the instrument panel's grounding at the fixing points.

## WINDSHILD WASHER

The Saab 95 and 96 are equipped with a mechanical windshield washer, the pump of which is combined with the windshieldwiper switch.

GT 750 has an electrical pump, started with the same switch as that of the windshield wipers.





## WIRING

The cables and wires of the electrical system, carrying current from battery or generator to the various points of use, are made up as far as possible into harnesses, i.e. a number of individually insulated wires are run together in an enclosing plastic sheath. This protects the wiring and reduces the risk of short circuits.

There are three main harnesses: one under the hood, one along the dash panel and in the engine compartment, and one running to the rear of the car. Providing the wiring diagrams reproduced here are carefully followed, removal and installation of wires and cables should not present any difficulties. The various component wires are color marked according to the number designations given on the diagrams and in the accompanying tables.

Cable connections are made with AMP connectors. For wiring repairs and joining with AMP connectors,

Check that all cables and wires are properly connected, thus avoiding unnecessary voltage drops and or arcing.

Check that lead from horn button is routed so that it is not likely to be damaged by steering wheel movement.

If frequent fuse burn-out is encountered and no other causes are apparent, test the harnesses for insulation. Remember that the fuse will not blow, however, if a short occurs in the circuit prior to the fuse.

When fitting new wiring always check that the selected material is adequate for the loading involved, and that cables are properly protected where they pass through panels and at clamps.

## FUSES

To reduce fire risks and protect wiring, ammeter, etc., from abnormal current strengths, such as may result from short circuits, the system is provided with twelve 8-amp. fuses, located on a block fixed to the dash panel at the right side of the engine compartment. Two of the fuses are reserved for extra equipment or as spares. All electrical equipment is fused except instrument lighting and ignition system. The applications of the various fuses are marked on the inside of the fuse-block cover. An additional fuse block, located beside the regular block, is fitted in the GT 750.

### NOTE

Be careful when replacing a fuse to secure a good contact. When wire fracture is suspected, check first that the appropriate fuse is in good contact.

## SAAB 95 UP TO AND INCLUDING CHASSIS 10.800

The wiring diagram opposite represents the Saab 95 electrical system. For easy identification, wires and cables are color coded as per the table below.

Black:	1, 7, 18, 19, 23a, 24a, 32, 37, 45, 46, 47, 48, 49, 71, 77, 78, 79, 80.
Red:	2, 5, 8, 9, 10, 11, 14, 15, 20, 21, 27, 28, 33, 34, 39, 63, 65, 67, 72, 92.
Green:	16, 22, 50, 5, 52, 53, 54, 55, 56, 57, 58, 59, 60, 61, 86, 87, 88, 90, 91.
Grey:	4, 12, 13, 25b, 26b, 29, 35, 36, 38, 44a, 62, 64, 69, 70, 74, 75, 76.
White:	23b, 24b, 40, 41, 42b.
Yellow:	17, 25a, 26a, 30, 43, 44b, 66, 73, 81, 82, 83, 84, 89a, 89b.
Blue:	42a.

### NOTE

Saab 95 cars up to chassis No. 1700 have the same wiring as the Saab 93 from chassis No. 49801, except for leads to rear lights.

Legend (circled figures on wiring diagram)

1. Parking and turn indicator lights
2. Headlights
3. Horns
4. Distributor
5. Spark plugs
6. Generator
7. Fuel pump
8. Starter motor
9. Battery
10. Voltage regulator
11. Fuse box
12. Ignition coil
13. Heater fan motor
14. Windshield wiper motor
  - a. SWF
  - b. Bosch
15. Stop-light-switch
16. Instruments cluster
17. Dip switch
18. Door switch for roof light
19. Road-light switch
20. Heater fan switch
21. Instrument-lighting switch
22. Turn indicator repeater light
23. Ignition and starting switch
24. Windshield-wiper switch
25. Cigar lighter
26. Turn indicator switch
27. Horn button
28. Fuel-gauge sender unit
29. Roof light and switch
30. Rear roof light
31. Stop lights and turn indicator lights
32. Parking lights
33. License light
34. Door switch for roof light



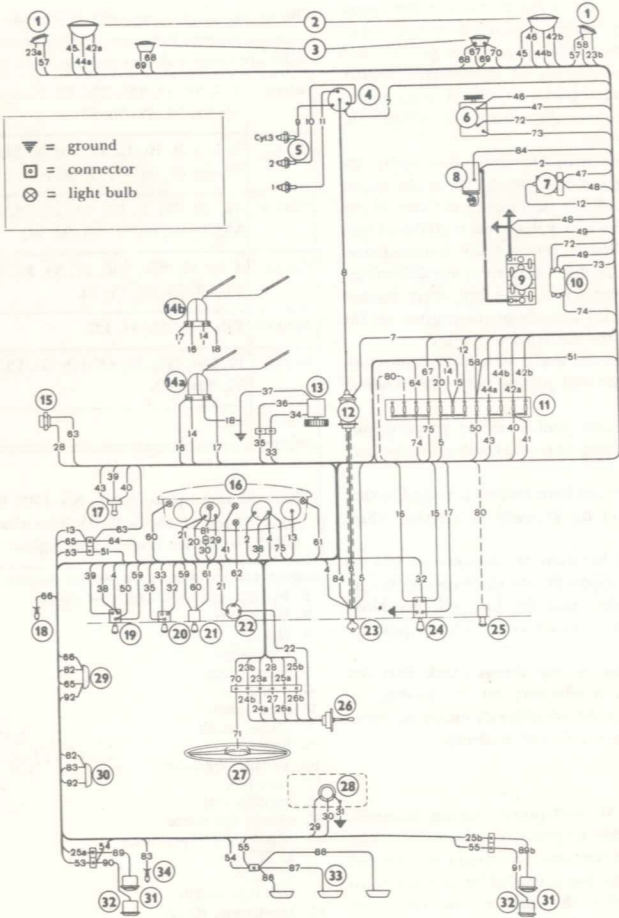

Wiring diagram, Saab 95  
Up to and incl. chassis No. 10.800



**SAAB 95 from chassis No. 10.801**

The wiring diagram opposite represents the Saab 95 electrical system. For easy identification, wires and cables are color coded as per the table below:

Black:	1, 7, 18, 19, 23a, 24a, 45, 46, 47, 48, 49, 71, 105, 109, 135, 136.
Red:	5, 8, 9, 10, 11, 14, 20, 21, 27, 28, 32, 39, 61, 63, 65, 67, 68, 72, 92, 126, 129.
Green:	16, 22, 50, 51, 53, 54, 55, 57, 58, 59, 60, 86, 87, 88, 101, 104, 110.
Grey:	4, 12, 25b, 26b, 29, 35, 44a, 62a, 62b, 64, 69, 70, 74, 75, 85, 93.
White:	23b, 24b, 40, 42b, 66, 82, 83, 118, 128a.
Yellow:	17, 26a, 33, 43, 44b, 73, 84, 128b.
Brown:	15, 30.
Blue:	13, 25a, 41, 42a.

**Legend (circled figures on wiring diagram)**

1. Parking and turn indicator lights
2. Headlights
3. Horns
4. Distributor
5. Spark plugs
6. Generator
7. Fuel pump
8. Starter motor
9. Battery
10. Voltage regulator
11. Fuse box
12. Ignition coil
13. Stop-light switch
14. Heater fan motor
15. Windshield-wiper motor
16. Turn-indicator repeater light
17. Charge indicator light
18. High beam indicator light
19. Electric clock
20. Coolant thermometer (lighting)
21. Speedometer and mileage recorder
22. Fuel gauge
23. Dip switch
24. Turn indicator flasher
25. Ignition and starter switch
26. Headlight switch
27. Instrument-lighting rheostat
28. Heater fan switch
29. Windshield-wiper switch
30. Door switches for courtesy light
31. Horn button
32. Turn indicator switch
33. Courtesy lights with switch
34. Fuel gauge sender unit
35. Stop lights, and turn indicator lights
36. Tail lights
37. License lights

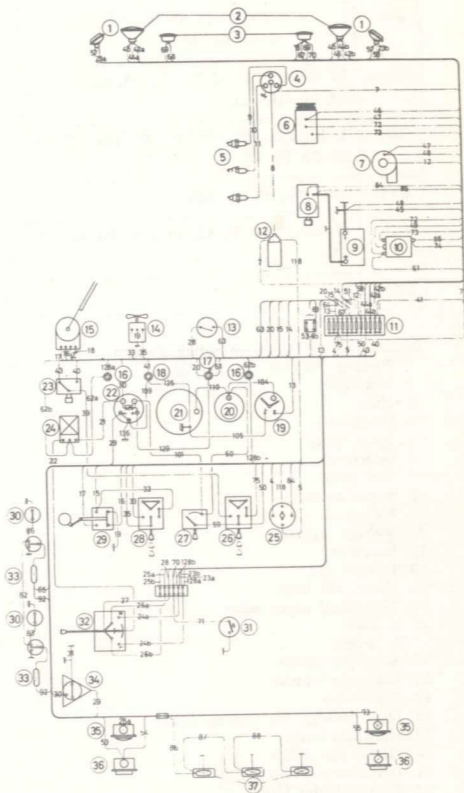

**Wiring diagram, Saab 95**  
From chassis No. 10.801



### SAAB 96 up to chassis 201.400

The wiring diagram opposite represents the Saab 96 electrical system. For easy identification, wires and cables are color coded as per the table below:

### NOTES

Black:	1, 7, 18, 19, 23a, 24a, 32, 37, 45, 46, 47, 48, 49, 71, 77, 78, 79.
Red:	2, 5, 8, 9, 10, 11, 14, 15, 20, 21, 27, 28, 33, 39, 63, 65, 67, 68, 72.
Green:	16, 22, 50, 51, 52, 53, 54, 55, 56, 57, 58, 59, 60, 61, 121.
Grey:	4, 12, 25b, 26b, 29, 35, 38, 44a, 62, 64, 69, 70, 74, 75, 76.
White:	23b, 24b, 40, 41, 42b.
Yellow:	17, 25a, 26a, 30, 43, 44b, 66, 73, 81, 84, 122.
Blue:	42a.

### Legend (circled figures on wiring diagram)

1. Parking and turn indicator lights
2. Headlights
3. Horns
4. Distributor
5. Spark plugs
6. Generator
7. Fuel pump
8. Starter motor
9. Battery
10. Voltage regulator
11. Fuse box
12. Ignition coil
13. Heater fan motor
14. Windshield-wiper motor
  - a. SWF
  - b. Bosch
15. Stop-light switch
16. Instrument cluster
17. Dip switch
18. Door switches for courtesy light
19. Headlight switch
20. Heater fan switch
21. Instrument-lighting switch
22. Turn indicator flasher
23. Windshield-wiper switch
24. Ignition and starter switch
25. Trunk light
26. Turn indicator switch
27. Wheel with horn button
28. Fuel-gauge sender unit
29. Courtesy light with switch
30. Stop and turn indicator lights
31. License lights

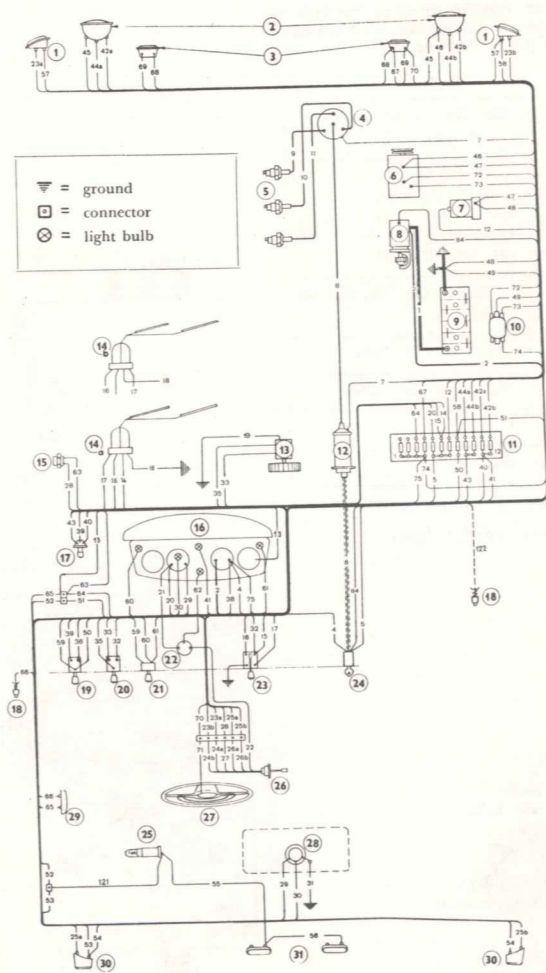

S 267

**Wiring diagram, Saab 96**  
Up to chassis No. 201.400 inclus.





**SAAB 96 from chassis No. 201.401**

The wiring diagram opposite represents the Saab 96 electrical system. For easy identification, wires and cables are color coded as per the table below:

Black:	1, 7, 18, 19, 23a, 24a, 45, 46, 47, 48, 49, 71, 105, 109, 135, 136.
Red:	5, 8, 9, 10, 11, 14, 20, 21, 27, 28, 32, 39, 61, 63, 65, 67, 68, 72, 126, 129.
Green:	16, 22, 50, 51, 52, 53, 54, 55, 56, 57, 58, 59, 60, 101, 104, 110, 121, 133.
Grey:	4, 12, 25b, 26b, 29, 35, 44a, 62a, 62b, 64, 69, 70, 74, 75, 85.
White:	23b, 24b, 40, 42b, 66, 118, 128a.
Yellow:	17, 26a, 33, 43, 44b, 73, 84, 128b.
Brown:	15, 30.
Blue:	13, 25a, 41, 42a.

Legend (circled figures on wiring diagram)

1. Parking and turn indicator lights
2. Headlights
3. Horns
4. Distributor
5. Spark plugs
6. Generator
7. Fuel pump
8. Starter motor
9. Battery
10. Voltage regulator
11. Fuse box
12. Ignition coil
13. Stop-light switch
14. Heater fan motor
15. Windshield-wiper motor
16. Turn-indicator repeater light
17. Charge indicator light
18. High beam indicator light
19. Electric clock
20. Coolant thermometer (lighting)
21. Speedometer and mileage recorder
22. Fuel gauge
23. Dip switch
24. Turn indicator flasher
25. Ignition and starter switch
26. Headlight switch
27. Instrument-lighting rheostat
28. Heater fan switch
29. Windshield-wiper switch
30. Door switch for courtesy light
31. Horn button
32. Turn indicator switch
33. Courtesy light with switch
34. Fuel gauge sender unit
35. Stop lights, turn indicators and tail lights
36. License lights
37. Trunk light

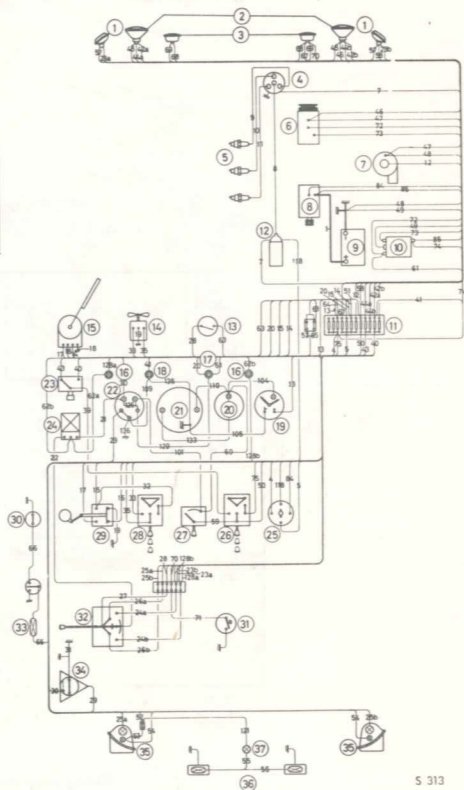

**Wiring diagram, Saab 96**  
 From chassis No. 201.401



### SAAB GT 750

The wiring diagram opposite represents the Saab GT 750 electrical system. For easy identification, wires and cables are color coded as per the table below.

Black:	1, 7, 18, 19, 20, 23a, 24a, 32, 37, 45, 46, 47, 48, 49, 71, 80, 88, 89, 91, 105, 107, 108, 109.
Red:	5, 8, 9, 10, 11, 14, 15, 21, 27, 28, 33, 34, 39, 61, 63, 65, 67, 68, 72, 86, 90.
Yellow:	17, 25a, 26a, 43, 44b, 66, 73, 84, 99, 100.
Green:	16, 22, 50, 51, 52, 53, 54, 55, 56, 57, 58, 59, 60, 81, 82, 83, 101, 102, 103, 104.
Blue:	42a, 62.
Grey:	4, 12, 25b, 26b, 29, 35, 36, 38, 44a, 64, 69, 70, 74, 85, 87, 92, 93, 94.
White:	23b, 24b, 30, 40, 41, 42b, 95, 96, 97, 98.

The Saab GT 750 electrical system is a modified form of the system in the Saab 96. AMP connectors are employed only for those items which are common to both models, not for the following parts exclusive to the Saab GT 750:

- Electrical windshield-washer pump
- Revolution counter
- Speed Pilot (dial illumination)
- Resistance in ignition-coil primary circuit
- Back-up lights with switch and warning light
- Extra leads and switches for additional road lights
- Extra 4-fuse block
- Cigar lighter

The ignition circuit is fitted with a warning lamp instead of ammeter.

Legend (circled figures on wiring diagram)

1. Parking and directional-signal lights
2. Headlights
3. Horns
4. Extra lights
5. Distributor
6. Spark plugs
7. Generator
8. Fuel pump
9. Starter motor
10. Battery
11. Voltage regulator
12. Fuse box
13. Resistance
14. Ignition coil
15. Heater fan motor
16. Windshield-wiper motor
17. Windshield-washer pump
18. Stop-light switch
19. Dip switch
20. Instruments
21. Halda Speed Pilot
22. Door switch
23. Light switch
24. Heater fan switch
25. Flasher unit
26. Windshield wiper switch
27. Ignition and starter switch
28. Cigar lighter
29. Back-up light switch with ind. light
30. Switch for optional lights
31. Instrument illumination switch
32. Extra switch
33. Turn indicator switch
34. Horn button
35. Courtesy light with switch
36. Fuel gauge, sender unit
37. Tail, stop and turn indicator signal lights
38. Back-up lights
39. License plate lights

### NOTES

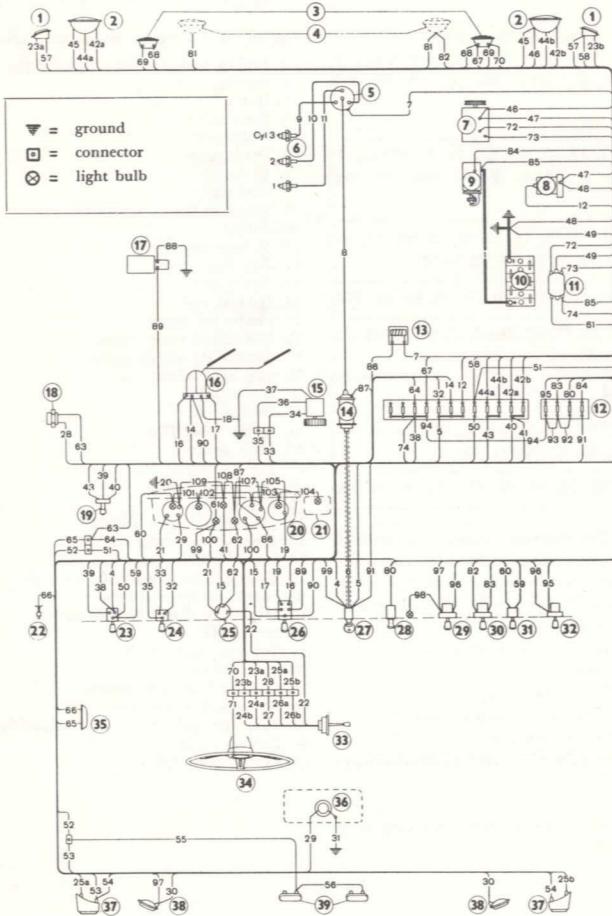

Wiring diagram, Saab GT 750



### CARS FITTED WITH SAXOMAT CLUTCH

Cars fitted with the Saxomat automatic clutch are provided with extra wiring, connected as shown below.

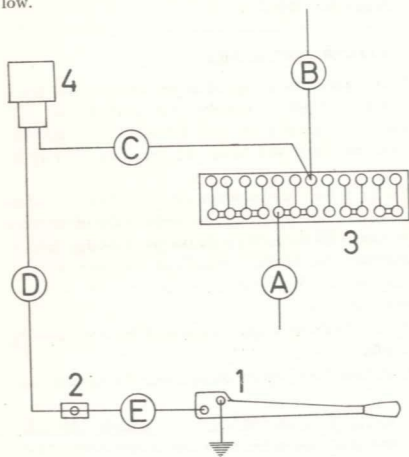

Wiring diagram for Saxomat clutch

1. Gear-shift lever
  2. Connector
  3. Fuse block
  4. Operating valve
- A. Input lead from ignition switch (red)  
B. Lead to fuel pump (grey)  
C. Positive lead to operating valve (green)  
D. & E. Ground lead from operating valve via gear-shift lever contact gap (black)

### REPAIRS AND ADDITIONAL WIRING

The use of solder for producing electrical connections has been superseded by AMP-terminals crimped on the wires. Apart from ordinary ring tongue terminals also certain automotive types are used to provide simplified electrical assembly.

**Saab 96.** The wires are to a large extent connected to the components by Faston receptacles. To provide separable connections Fastin-Faston harness connectors are used. A larger type of them is fitted to headlights and flasher unit. For permanent connection pre-insulated splice connectors are used.

**Saab 95 and GT 750** are mainly fitted with same parts as Saab 96.

**Saab 93.** The wires are to a certain extent connected to components by Shur-Plug terminals. Together with connectors these are also used as separable connections. In recent models Fastin-Faston connectors are used on headlights.

### DESCRIPTION

**Faston connections** are of the "push on" type. Two rolled springs provide high and constant electrical contact over the tab. Detent action is provided by an independently sprung ramp shaped dimple. When repairing, these should be replaced by corresponding pre-insulated parts. For connecting accessories the new wires should be terminated with Piggy-Back receptacles, which provide male tabs for the primary receptacles. The Piggy-Back receptacles are then fitted to the primary tabs.

**Fastin-Faston harness connectors** consist of receptacles and tabs featuring small locking lances to secure inadvertent retraction from the housings. Both units provide positive insulation for the completed assembly.

If, exceptionally, a receptacle has to be retracted from the housing, a 1/16" drill or steel rod should be inserted into the track on the front side of the housing to disengage the locking lance. When inserting again, check correct angle of lance.

When repair of harness connector or part thereof is required, replace by pre-insulated Faston receptacles and connectors.

A larger type of the receptacles and a corresponding housing is fitted to headlights and flashing relay. When repairing, replace by corresponding pre-insulated receptacles.

**Shur-Plug** is a 5/32" bullet type terminal with special nose crimp providing a reduced over-all length.

When repairing, replace by corresponding service-parts. When used as separable connections, these could be replaced by Faston receptacles and connectors.

### SERVICE ASSEMBLY

The primary production types are not advisable for repair use and accessory connection. Instead, pre-insulated terminals, splices, Faston receptacles and connectors should be used.

**Pre-insulated terminals**, type Plasti-Grip, are made from high-conductivity copper, electro-tinned for corrosion resistance. Barrel of terminal is serrated so that under crimping pressure the strands of wire "flow" into these serrations making a connection of great tensile strength. Bell mouth opening assures easy wire insertion.

They have a vinyl insulation sleeve withstanding ordinary oils, gasoline and corrosive agents. This extends from the back of the barrel to provide a support for the wire.

The insulation sleeve is color-coded by wire size, in accordance with table shown below to facilitate selection and eliminate errors during installation.





Wire Size Range		Color-Coding
AWG	mm <sup>2</sup>	
22—16	0,5—1,5	Red
16—14	1,5—2,5	Blue
12—10	3—6	Yellow

Pre-insulated splices, type Plasti-Grip, incorporate the same design features as terminals. A wire stop in the center of the splice facilitates the proper placement of wires.

Pre-insulated Faston receptacles are made of brass, electro-tinned for corrosion resistance. The insulation sleeve is bonded to a special sleeve providing a firm support to the wire insulation.

## SPEEDOMETER

### SAAB 95 AND 96

#### REMOVAL AND INSTALLATION

In order to remove the speedometer and mileage recorder it is necessary to remove the entire instrument cluster.

#### WARNING

Always disconnect battery lead to avoid burning-out ammeter.

1. Disconnect all cables, leads to warning lamps and speedometer drives. If it is necessary to disconnect the temperature gauge, do this at the panel, which is much simpler than draining the cooling system and disconnecting the sender unit from the engine.
2. Back off the two milled nuts at rear of instrument panel, one on each side of cluster. The right nut retains a ground lead.
3. Pull instrument cluster forwards and remove screws retaining bezel: viz. the left of the two screws on which milled nuts were fitted, and a hex screw close to speedometer drive connection. Remove bezel.
4. Remove mask from right instrument-panel lamp, permitting removal of clock. Remove fuel gauge and ammeter.
5. Speedometer and mileage recorder are integral with the housing and these parts are not serviced separately.
6. Refit in reverse order.

#### NOTE

Remember to reconnect the ground lead to the right fixing screw.

#### NOTE

The Saab 95 up to chassis No. 1700 has the same instrumentation as the Saab 93 (from chassis No. 36751).

#### SPEEDOMETER CABLE

When handling the speedometer drive cable, never coil it in rings of less diameter than 12 in. (300 mm.) — otherwise the flexible inner wire may become damaged and cause noise trouble after refitting.

To fit a new speedometer cable or flexible inner wire, to a l.h. drive car, first remove the glove-compartment lid by backing off the six retaining screws, accessible inside the compartment. It may also be desirable to disconnect the upper end of the right defroster hose.

When installing a speedometer cable, note the following:

1. Release the cowlplate lining under the freshair vent.
2. Secure the upper cable nut to the cable with tape, and push the cable from the engine compartment through the hole in the cowlplate.
3. Be careful to arrange the cable in a wide curve behind the glove compartment, to avoid sharp bends. At each end it should be arranged as straight as possible for a length of about 8 in. (200 mm.)

### SAAB 95 AND 96 FROM YEAR MODEL 1964

#### REMOVAL AND INSTALLATION

As this instrument forms a separate unit, it can be removed and installed without affecting other units.

1. Disconnect all leads to the ground connection, pull out the lamp sockets together with the connecting leads, and disconnect the speedometer cable.
2. On the Saab 96: Loosen the knurled centre nut for the retaining bracket.  
On the Saab 95: Loosen the two knurled nuts which hold the retaining bracket.
3. Pull the instrument out of the instrument panel.
4. Refit in reverse order. When doing this, the step in or line along the periphery of the casing shall correspond to the recess in the hole for the instrument in the panel.

Repair or adjustment, when needed, of this instrument should be made by a specialized workshop.



## CLOCK AMMETER, FUEL AND TEMPERATURE GAUGES, SAAB 95 AND 96 UP TO AND INCL. MODEL 1963 GENERAL

The ammeter and fuel and temperature gauges can be removed without disassembling the entire instrument cluster. Removal is facilitated if the cluster is released from the instrument panel and lowered forwards.

### WARNING

Always disconnect battery lead before working on instruments.

### CLOCK

To remove the clock it is necessary to release the instrument cluster and remove the bezel together with lenses. This permits removal of the mask for the instrument lamp under the dial.

### TEMPERATURE GAUGE

If the temperature gauge is suspected of being in error, check by removing the sender unit from the cylinder head and dipping it in a container full of water. Heat the water to boiling point and check the indicated temperature against a calibrated thermometer also held in the boiling water. Neither sender unit nor thermometer should touch the bottom of the container.

Graduations on the flange of the temperature-gauge dial are visible when viewed from the side.

## SAAB 95 AND 96 FROM YEAR MODEL 1964

Each one of these instruments can be removed separately. Re fitting,

Repair and adjustment, when needed, of these instruments should be made by a specialized workshop.

## REVOLUTION COUNTER

### GENERAL

The GT 750 is equipped with an electric revolution counter connected to the ignition primary circuit, see wiring diagram in fit a revolution counter in a Saab 96, for example, follow the wiring diagram below.

### WARNING

Do not confuse + and - leads, or the instrument may be damaged.

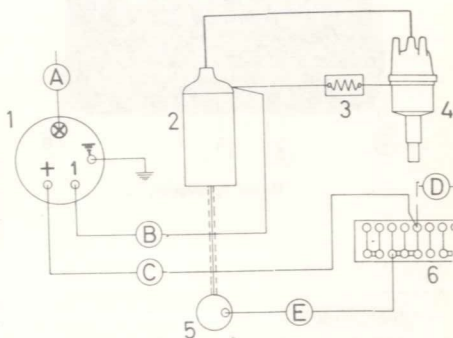

1. Rev. counter
2. Ignition coil
3. Resistance
4. Distributor
5. Ignition switch
6. Fuse block

- A. Instrument lamp lead
- B. Lead between coil and terminal 1 on counter
- C. Lead between fuse block (fuel pump) and terminal on counter
- D. Lead to fuel pump
- E. Lead out from ignition switch to fuse block

## SPEEDPILOT

The GT 750 is equipped with a time-and-distance recorder, the Halda Speedpilot, driven by the speedometer cable through a take-off gear.

1. Knob for setting to 2nd scale.
2. Average speed dial. With knob 1 set for 2:1 scale, a.s. dial readings must be halved, i.e. with needle at 80 correct speed is 40.
3. Clock/pilot dial. Pilot hand indicates relative to minute hand the number of minutes that the car is ahead or behind schedule.
4. Fine-adjustment knob.
5. Trip recorder zeroing knob.
6. Trip recorder.
7. Two-position knob for setting desired average speed (inner pos.) or adjusting clock pilot hand (outer pos.).
8. Two-position knob for winding up and resetting clock.

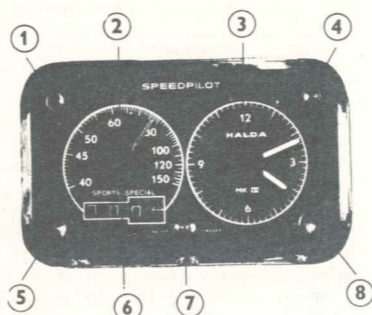

Halda Speedipilot

### ADJUSTMENTS

Instrument readings may be adjusted by means of the screw on the underside of the instrument case. Proceed as follows:

Select a measured road distance of at least 20 km. (12 miles). Check that car tire pressures are correct. Set trip recorder to zero and drive the selected route. Then, using the formula below, calculate the required correction  $N$  in terms of screw turns towards (+) or (-) marks. Terms  $T$  and  $D$  correspond to indicated and actual distances, respectively. If no measured distance is available, the regular mileage recorder in the car may be used to obtain  $D$ , but the result will not be quite so accurate.

The following two typical examples illustrate the use of the formula, which is identical for kilometers and miles.

Pilot trip meter shows less than the actual distance.

The screw must be turned towards plus (+).

$$N = \frac{100 \cdot (D-T)}{T}$$

Example: Actual distance  $D=3$ .

Trip meter shows  $T=2.9$ .

$$N = \frac{100 \cdot (3-2.9)}{2.9} =$$

$$\frac{100 \cdot 0.1}{2.9} = \frac{10}{2.9} = 3.45$$

The screw must thus be moved 3.45 turns towards plus (+).

Pilot trip meter shows more than the actual distance.

The screw must be turned towards minus (-)

$$N = \frac{100 \cdot (T-D)}{T}$$

Example: Actual distance  $D=3$ .

Trip meter shows  $T=3.1$ .

$$N = \frac{100 \cdot (3.1-3)}{3.1} =$$

$$\frac{100 \cdot 0.1}{3.1} = \frac{10}{3.1} = 3.23$$

The screw thus be moved 3.23 turns towards minus (-).

### NOTES

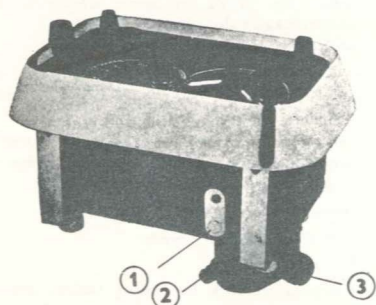

Underside of Speedipilot

1. Adjustment opening
2. Lubrication nipple
3. Connection for drive wire



## DESCRIPTION

### GENERAL

The Saab 95, 96 and GT 750 models all have bodies of unit construction, without a separate chassis frame. Fenders, doors, hood and rear lid are separable from the main assembly, which is composed of a relatively small number of pressed steel parts. These parts are joined along the overlapping joints by spot or tack welding, as well as solid welding at all vital junctions. Illustrated are the parts comprised in the welded body assemblies. The body of the Saab GT 750 is nearly identical with that of the Saab 96, the only notable difference being the two moldings low down at the sides, which on the GT 750 replace the fender moldings. Remarks in this chapter referring to the Saab 96 therefore refer also to the GT 750.

The rear and roof panel of the Saab 95 are different from the corresponding parts of the Saab 96, but the front ends of the two models are identical.

The roof panel is a single pressing extending from the cowl plate to the leading edge of the rear window, pressed reinforcement frames have been fitted, in the windshield pillars and steel section roof rails add rigidity to the roof edges.

The cowl section of the roof panel terminates in a vertical reinforcement panel which, with the cowl plate and the windshield reinforcement panel, forms a closed compartment. This space serves as a collecting chamber for ventilation air, which flows in through the opening in the upper side of the chamber and may be admitted to the car either through a flap located in the cowl plate at right or through the fresh-air heater.

The floor is a single smooth panel, channeled longitudinally for requisite stiffening. Reinforcement at the sides is provided by the sills, to which jack supports are welded. At the front the floor panel adjoins the cowl plate, at the rear the rear-axle tunnel. The engine compartment floor and luggage compartment floor pans are joined to the center floor at cowl plate and rear-axle tunnel respectively.

The wheelhouses are of pressed steel, channeled for reinforcement. The front wheelhouses are pierced for the suspension arms and tie rods and also to allow the escape of air passing through the radiator. The air outlets are fitted at the bottom with two gilled splash guards. The two round openings are provided with covers, which should be removed during summer weather. Brackets for the front suspension arms are welded to the inside of the wheelhouses and engine compartment floor pan.

One of the rear wheelhouses is pierced for the fuel filler pipe, while the other is fitted with a bracket for the rear exhaust pipe. Upper spring seats and shock-absorber attachments are welded to wheelhouses, at both front and rear.

The luggage compartment of the Saab 96 and GT 750 is enclosed within the rear portion of the body and limited at the front end by the removable rear seat back. The compartment is floored with a plywood panel in two parts, under which the fuel tank and spare wheel are housed. The rear compartment lid is carried on two hinges and fitted with a counterbalanced check device.

In the Saab 95 the entire space to the rear of the front seats may be made available for luggage by dropping the rear seats.

### BODY INSULATION

Passenger and rear compartments are internally insulated with waffle-pattern paperboard. A layer of insulation compound has also been sprayed on the underside of the body assembly and inside the wheelhouses. This compound affords protection against flying stones and corrosion, besides having certain sound absorbing properties. When cleaning the car, never scrape the inside of the wheelhouses.

## BODY ASSEMBLY

### GENERAL

It is possible to replace parts of the body assembly which have suffered damage and where correction by beating or straightening is not suitable. Frequently even minor damage may be more quickly and cheaply repaired, and with better results, if the parts affected are replaced rather than repaired. Parts of the body assembly which are regularly serviced are illustrated below.

### REMOVAL OF DAMAGED BODY PANELS

When disassembling damaged body panels beware of stresses and deformation resulting from the use of burner tools for cutting. Shears, metal saws and pneumatic chisels are to be preferred.

A method which often simplifies work is to cut away with a burner at a distance from the scribed line of at least 1 in. (30 mm.) and then make the final trim with cold-working tools.

Thus, to remove tack-welded panels burn away as close to the weld line as possible, without risking heat deformation of the undamaged panel. Finally prise away the remaining metal strip and grind or chisel off any weld remains.





Spot-welded parts are removed in the same way, with similar care to avoid deformation of good panels. After burning, drill through each weld using a drill bit of slightly greater diameter than the spot weld, and drilling only the panel to be removed. As drilling proceeds, roll and prise away the metal strip, cleaning up any weld remains.

### WELDING NEW BODY PANELS

Spot-welded parts should be replaced by spot welding. This is specially applicable to water channels and other visible components. A wide range of welding rods for spot welding is generally available through the usual dealers. If not obtainable, however, plug welding may then be resorted to. Drill  $\frac{3}{16}$ -in. (5-mm.) holes in the overlying panel at the same centers as the previous spot welds. Assemble the panels and fill the holes with the electric welder. It is difficult with this method to obtain a smart finish at visible places.

Remake formerly tack-welded seams by electric welding in the same fashion as the original weld.

If only part of a body panel has been replaced, the new piece must be joined by acetylene welding. Locate the parts flush with the new joint in close contact. If double sheet is involved weld on both sides. Fix the parts firmly with a few tack welds before starting the main weld, to prevent skewness during welding. Carry out the acetylene weld in short passes and hammer each section immediately, before cooling, to even out residual stresses.

### SEALING AND FINISH

It is important that new body panels are effectively degreased after welding. Priming and enameling may then be carried out.

Treat the undersides of wheelhouses, fenders, scuff plates and floor sheets with underseal composition. Panel seams through which water can enter the car must be closed with body sealing compound. Among especially important joints may be noted the joint between roof sheets and water channel, and that between upper and lower external valances.

### REPAIRS TO FRONT END OF BODY DISASSEMBLY

Work is simplified if all parts affected by the job in hand are removed from the car, such as hood, fenders, engine and transmission, and suspension parts on the damaged side. If one wheelhouse only is damaged it may suffice if the engine is removed together with suspension parts on the affected side. Disassembly is described in the appropriate chapters.

### Wheelhouse

To remove a damaged wheelhouse, drill or cut it free from the front sheet and floor sheet and cut away the suspension-arm bracket as close as possible to the floor. If the cowl plate is undamaged then preferably cut the wheelhouse away a little forward of the cowl plate. This simplifies fitting the new wheelhouse since insulation and electrical wiring inside the car may be left intact. Commence cuts from the original holes to facilitate trimming of the new wheelhouse panel to the same pattern and thus ensure that a good fit will be obtained. If only the front part of the wheelhouse is damaged it may be possible to restore it by bumping, at lower cost than replacement.

If replaced, it is best to make the joint as described above even if the rear portion is undamaged, thus avoiding visible welded seams.

### Floor pan

Damaged parts of the floor sheet must be removed with a gas cutting tool. Cut about 1 in. (30 mm.) clear of the scribed line, then trim with cold tools to the marked profile. The marks should commence from existing holes to facilitate cutting of the new part to exactly the same shape.

The joint should preferably be located as shown in the illustration. If the entire floor sheet is damaged, remove it by prising away the spot weld at the cowl plate.

If one or both wheelhouses remain undamaged portions of the floor may be replaced by cutting the panel free from the wheelhouses and, if necessary, from the cowl plate and suspension brackets, with a gas cutter. Remains of the floor sheet at brackets, cowl plate or wheelhouses may be broken away or chiseled off. Grind away the old welded joint and tack-weld at the bottom edge of the original wheelhouse.

A bend in the main floor sheet behind the cowl plate should be corrected before removing damaged parts. Firmly secure a beam transversely across the floor and apply a jack on each side between the sill and the beam. The floor sheet can then be drawn into correct alignment.

### Front lower panel

The front lower panel is generally replaced entirely. To remove, grind away the tack weld to the floor pan and drill out the spot welds to the wheelhouses.

### REASSEMBLY

When replacing parts of the body front end take great care to locate them correctly relative to the rest of the body, otherwise problems of wheel alignment, etc., will arise. See the dimensioned drawings for correct body dimensions.



Floor pan

1. Remove rear engine mounting and align the cowl plate if necessary.
2. Straighten and trim cut edge of former floor sheet.
3. Fit new panel, preferably employing a jack and tool No. 784077 — see fig. Fit the tool under the body in the brackets for the rear axle side links. Locate the front hole for the stabilizerbar bearings, in the floor sheet, on the tool stubs and then lift the pan to

correct position. A stud bolt is supplied for fitting into one of the pedal-frame bolt holes to keep the alignment tool in position.

In the absence of the proper alignment tool the floor pan may be fitted according to the dimensions given on the illustration, between the side-link brackets and the holes in the panel for the stabilizer-bar bearings.

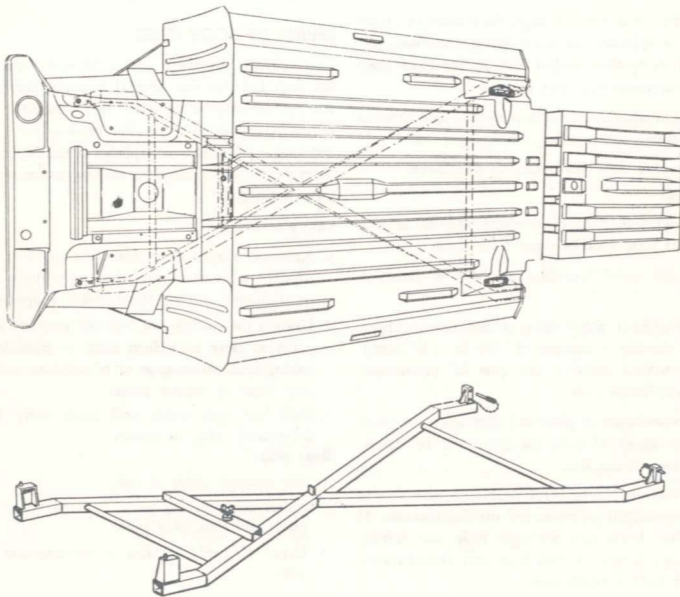

Location of tool No. 784077 for diagonal alignment of body assembly



4. Scribe the new panel to correspond to cut edges of old panel.
5. Remove new pan from car and cut along scribed lines.
6. Refit panel in tool and locate at rear.
7. Jack new floor pan to right height and check distance between front and rear engine mounting points, using tool No. 784078 as illustrated. Incorrect measurements indicate the need for further realignment of cowl plate.  
If tool No. 784078 is not available refer to dimensions given on illustrations.
8. Join wheelhouse to floor sheet with bolts through holes for lower suspension-arm brackets.
9. Weld floor sheet at rear edge, commencing with a tack at center and continuing with 2—2½ in. (50—60 mm.) passes on alternate sides. Hammer after each tack, before it cools. Remove locating tools after rear edge is welded.
10. With the aid of the jack align floor sheet to correct height as indicated on dimensioned illustration. By bolting on bumper bracket with its bar floor sheet will be retained in correct position.
11. Tack weld wheelhouse brackets to floor and hammer weld before cooling, using a holding-up tool.
12. Spot or plug weld floor sheet to wheelhouse

#### Wheelhouse

1. Align and trim edge of previous wheelhouse and grind off weld remains from floor sheet.
2. Scribe new panel according to shape of removed part.
3. Cut replacement panel along scribed line at upper flange, leaving a margin of 3/4 in. (20 mm.) outside scribed mark at the part of wheelhouse below ventilation hole.
4. Clamp wheelhouse in place and tighten against floor sheet by means of bolts through holes for lower suspension-arm brackets.
5. Use a jack to locate floor sheet and wheelhouse at correct height as indicated on illustrations. If panel has been cut through hole for fender bolt, check length of this hole and also distance between both wheelhouses.
6. Fit hood and check relative fit of hood and wheelhouses.
7. Raise hood again and weld wheelhouse at top flange. Weld wheelhouse side stay.
8. Using a hacksaw, cut away surplus sheet metal below ventilation hole (safety margin as described above) and finally weld wheelhouse at rear edge.
9. Tack weld wheelhouse to floor sheet and weld transverse member between brackets, and radiator shield.

#### Front lower panel

1. Locate new front sheet with the aid of clamps.
2. Tack weld in place.

#### Other operations

1. Weld wheelhouse and front lower panel seams at floor sheet.
2. Cut requisite holes and apply surface finishes. Finally fit rear-axle side links, front suspension, power assembly, etc.

#### NOTE

Stud for shock-absorber attachment must be welded to inside of wheelhouse.

Check each part as reassembled for possible damage — especially suspension arms and steering-gear parts. Replace damaged parts with new items.

#### REPAIR OF BODY SIDES

In a collision involving a blow from the side not only the door but also the external valances, rear pillar and scuff plates may be distorted. Any noticeable distortion of the rear pillar is reason for replacement.

External valances may be replaced in their entirety, while damaged parts of scuff plates may be cut for replacement.

#### DISASSEMBLY

##### Side panel Assy

1. Remove door, rear fender, quarter window, quarter trim and any other trim items likely to be damaged during the following operations.
2. Using a gas cutting tool, remove damaged lower side panel as close to welded seam as possible without risking heat deformation of wheelhouse, scuff plates, rear pillar or quarter panel.
3. Drill out spot welds and break away remaining sheet-metal strip, as shown.

##### Rear pillar

1. Saw through pillar at roof.
2. Chisel away welded joint between pillar and scuff plate, and pull away pillar.
3. Grind off weld remains at waterchannel and scuff plate.

##### Scuff plate

Partial damage to the scuff plate may be repaired by sawing out the affected part and welding in a new piece.

4. Grind away remains of welds.
5. If damaged, the quarter panel may be removed in the same manner as the side panel. On the Saab 96 the quarter panel is joined to the quarter-window and rear-window reinforcement panels, roof panel, rear compartment surround and wheelhouse. There is a tinned seam at the lower side of the rear window,





## REASSEMBLY

### Scuff plate

1. Fit and align new panel and weld in place.
2. Tidy up welds and fill with tin at visible points.

### Rear pillar

1. Align rear pillar to conform to dimensions shown on illustrations. Weld temporarily in place.
2. Test fit new or realigned door.
3. Adjust to secure correct clearances round door by correcting pillar alignment.
4. Remove door and weld rear pillar finally.

### Side panel assy.

1. If only lower external valance has been removed, drill holes for plug welding in upper flange of new panel. See fig.
2. If no spot-welding equipment is available, also drill holes for plug welding in flanges adjoining rear pillar, scuff plate and wheelhouse.
3. Fit external valance and align with the aid of clamps.
4. Plug weld top flange to quarter panel and spot or plug weld other joints.
5. If entire external valance assy. has been removed it may be replaced as a single part, in the case of the Saab 96. Weld the assembly to rear pillar, reinforcement panels and wheelhouse, using plug or spot welding as described in (4), above. At roof and below rear window use acetylene welding, and smooth the weld below the rear window by tin filling.

## REPAIR OF ROOF ASSY.

If the roof is so badly damaged that bumping is not economically feasible, the entire roof sheet including water channels and drip moldings, may be replaced.

## DISASSEMBLY

1. Jack up car and support on blocks under scuff plates and wheelhouses, on a level floor, to ensure that body will not change shape when roof is removed.
2. Remove doors, trim and wiring, and protect instrument panel and steering wheel against damage.
3. Burn away damaged roof parallel with water channels, windshield and rear window as shown in illustration, leaving a narrow strip of metal at welded joints. Then drill out spot welds and break away remaining strip.
4. After removing electrical wiring in windshield pillars, saw through pillars immediately below curve of upper corner. Allow windshield reinforcement panel to remain undisturbed if not damaged.

## WARNING

Do not cut pillars too low down, as this will result in loss of roof support provided by tubular steel reinforcements.

5. Saw away any damaged sections of water channels, drip moldings, window reinforcements, and glass channels.
6. Grind off weld remains.

## REASSEMBLY

1. Fit new windshield reinforcement if required, using a windshield glass as templet for opening.
2. Replace any damaged parts of water channels and moldings. Doors must be test fitted to ensure correct clearance.
3. Measure diagonally location of upper end of rear pillars, to ensure symmetry and correct distance between pillars.
4. Adjust fit of new roof sheet at front edge, between windshield pillars. Use a spare glass to check size of windshield opening.
5. Attach roof sheet with a few tack welds at windshield reinforcement. Simultaneously clamp sheet at rear edge.
6. Spot or plug weld roof along water channels, starting at front end and working alternately on left and right sides.
7. Complete welding by spot or plug methods at windshield and rear window.
8. Weld roof sheet to windshield pillars and smooth off joint by tin filling.

## REPAIRS AT REAR END OF BODY ASSY

If a rear wheel has been struck in a collision the wheels and rear axle should be checked. If the rear axle bearings are misaligned remove the axle and correct the center bearing bracket. Also remove lower suspension arms at front end and release stabilizer bar from body attachments to permit fitting of tool No. 784077 for checking of rear axle side-link attachments.

Check furthermore that the center bearing bracket is located exactly midway between side-link brackets on underside of floor panel.

The rear compartment floor pan, rear body panels and rear wheelhouses are available as service parts and may be replaced if damaged, this being resorted to if warranted by shortage of time or expense of realignment of existing panels.

A rear end which has been compressed abreast the rear axle tunnel may be restored to shape by removing the rear fenders and bolting a strong beam between the rear bumper brackets.

With a jack fitted on each side between this beam and the sill ends the body may then be pressed out to correct shape.





## HOOD AND FENDERS

### REMOVAL OF HOOD

1. Open hood and disconnect electrical cables to headlamps and horn, blind control and hood ground lead.
2. Release hood stopper from hood.
3. Lift hood clear from hinge pins, in a forwards direction.

#### WARNING

Always lift off hood as soon as stopper is released. If supported only by hood stay it may easily fall accidentally to the floor.

### INSTALLATION OF HOOD

1. Locate hood on hinge pins, noting that rubber bushings of hinges are in good condition.
2. Check that hood is correctly placed relative to roof cowl section and front fenders. Location of hood may be adjusted by slight movements of hinge-pins.
3. Refit hood stopper and reconnect cables to head lamps and horn, blind control and hood ground lead. See wiring diagram and table in Chapter 15 for color coding of leads.

### HOOD LOCK

Adjustment of the hood lock may be made either by raising or lowering the outside angle brackets or by bending the latch to the desired shape.

### GRILLE

The center grille is attached to the hood by fastener clips on the inside of the hood and may be removed simply by releasing these clips. Side grille bars are fixed to the hood in the same manner.

### FENDERS

After a long mileage, especially on gravel roads, the underseal composition may be worn away at exposed points. Check regularly and make good as required. The rear fenders are especially subject to the effects of flying stones and gravel.

### DISASSEMBLY

When removing the rear left fender, plug the fuel filler tube with a clean linen rag to prevent entry of dirt into the tank while the cap is removed.

1. Remove wheel.
2. Release fender retaining screws starting at C and D, see fig.
3. Disconnect electrical cables as required, then release screws at B.
4. Release and remove fender, collecting sealing bead.

### REASSEMBLY

Before reassembling fenders treat with underseal composition, and refit moldings, lights and (left rear fender) rubber grommet.

Then:

1. Locate fender and sealing bead and insert screws B and C.
2. Align at corner "A" and tighten screws B and C to retain fender firmly yet permit further adjustment of alignment.
3. Fit other screws.
4. Check fender alignment and tighten all screws finally, but not so hard as to deform panel at sealing bead.
5. Reconnect cables and refit grommets or sleeves. Pass filler tube through rubber grommet and refit cap after removing temporary plug. Tighten clamps, if necessary.
6. Clip off surplus sealing bead below fender and refit wheel.

The clearance between the front fender and the door may be adjusted by removing the fender and hammering the vertical panel to which the fender is attached either to the front or rear.

## DOORS AND LIDS

### DISASSEMBLY OF DOOR

1. Remove interior trim.
2. Release door check by driving out pin at upper hinge.
3. Block up or suspend door in order to relieve hinges of weight.
4. Bend back locking tabs on external nuts.
5. Back off two nuts, accessible from inside door cavity, and remove door.

#### NOTE

Avoid damaging outside of door with tools used to release nuts.

6. Hinges may be removed from body.

### REASSEMBLY AND ADJUSTMENT OF DOOR

1. Fit hinges to body, if removed. Fit inner lock-nuts on hinge pivot pins.
2. Block up or suspend door in its correct position, and pass it onto hinge pivot pins.
3. Fit washers and hinge nuts inside door.
4. Check with care to see that door has correct clearance in opening.



## NOTE

Be careful to avoid damage to front fender when opening door without door check fitted.

- Adjust door to car longitudinal contours ("in-and-out" adjustment) by tightening and backing off nuts a little. Adjust door for height ("up-and-down" adjustment) by moving it up or down in elongated holes after releasing nuts slightly.
- As soon as door is correctly positioned and fits closely against weather strips, tighten all nuts and secure with tabs.
- Refit door-check pin and interior trim.

## DOOR LOCK REPLACEMENT

- Close door glass.
- Remove door trim.
- Unscrew internal lock retainer.
- Back off seven screws fixing door lock, four on inside of door and three on edge, pull lock free and remove from door.
- If required, outside door handle may be removed by backing off fixing screws, one inside door and one on edge.

Refit door handle and lock in reverse sequence. Check first that all moving parts of lock and lock springs are well lubricated with chassis grease.

Check that when pressing the button of the outside door handle, there is a clearance of 0.004—0.02 in. (0.1—0.5 mm). The clearance may be adjusted by gently bending the driver. After installation, adjust striker plate for easy door operation. Also make sure that the pawl engages satisfactorily at all positions.

## REPLACEMENT OF DOOR LOCK CYLINDER

After removal of door trim, remove outside door handle by loosening its fixing screws, one inside door and one on edge. Then remove and refit the door handle, as follows.

UP TO CHASSIS NO. 168 000  
DISASSEMBLY

- Remove screw 1 from inside of lock cylinder 6, and collect washers 2 and driver 3.
- Extract lock cylinder 6, and collect the two coil springs 5 and their spring seats 4.

## REASSEMBLY

- Place the springs 5 and the spring seats 4 in the lock-cylinder hole, and make the lock cylinder enter the handle.
- Fasten with screws the driver 3. When doing this, make sure that the lock cylinder and the driver are positioned so that the driver arm points to the rear or downwards when the key serration is uppermost, i. e. in the locked position.

FROM CHASSIS NO. 168.001  
DISASSEMBLY

- Press down push button 7, and drive out faucet 2 with a pin (max. 3 mm=0.12 in.). Remove arm, and washers 3 and 4.
  - Remove push button and spring 5.
  - Press the push button out of sleeve 6.
  - Insert key, and turn it 35° clockwise.
  - Press in catch pin 8 with a pin (max. 3 mm=0.12 in.).
  - Pull lock cylinder 9 out of push button.
- If the key has got lost, the catch pin can be forced into the lock cylinder with the aid of a center punch or a pin (max. 3 mm=0.12 in.), then it is possible to pull the lock cylinder out of the push button. This proceeding ruins the lock cylinder, which has to be renewed.

## REASSEMBLY

- Push the locking pin in, and press the lock cylinder into push button.
- Fit sleeve to push button, and the latter and spring to handle.
- Fit arm and washers, and drive faucet in. The hole of the washers differ — in size — from each other.

## ADJUSTMENT OF DOOR STRIKER-PLATE

The striker plate is adjustable, and can be moved by loosening the screws. Adjust the striker plate to secure easy door operation and that the striker plate does not force the door upwards or downwards. Also make sure that the pawl engages satisfactorily at all positions. Tighten the striker-plate screws securely, so they do not work loose.

## KEYS

Cars equipped with ASSA-locks — from chassis No. 168001 for the Saab 96, and from chassis No. 8401 for the Saab 95 — are accompanied by two different keys. One of them is a master key (its marking-No. begins with 2), which fits all locks in the car, the other is a secondary key (its marking-No. begins with 8), which can be used only for the door- and ignition locks.

## SPARE PARTS

In case of damage to a lock cylinder for door, luggage compartment or ignition, a new lock cylinder may be ordered. State the key's marking-No. and spare parts No. (See Spare Parts List). In this way it is possible to keep the system one key for all the locks in the car without need of replacing the complete lock set.

## LUBRICATION

If the lock cylinder is lubricated with oil or grease, it may happen that the lock pins stick in the cylinder. This is caused by dirt, which clings to the cylinder and then enters the lock cylinder. Therefore, avoid lubricating the very lock cylinder.

Should the key be slow-turning and need lubrication, a drop of glycerine may be smeared on the back of the key. NOTE! The dented side of the key must not be lubricated. Then turn the key to and fro a few times.



## REMOVAL AND REFITTING OF REAR COMPARTMENT LID

1. Raise lid, and release prop from lid.
2. Loosen hinge retaining screws at lid, and lift away lid.

### NOTE!

When removing and refitting lid take care not to damage paintwork.

3. Refit in the reverse sequence.

## REPLACEMENT OF REAR-COMPARTMENT LID LOCK UP TO CHASSIS 168.000 INCLUS.

1. Loosen the lock's four fixing screws. Remove lock.
2. Remove lock cylinder by — tapping with a drift — releasing the cylinder retaining nut, or — on earlier cars — twisting a spring-loaded locking plate a quarter-turn.
3. Refit in reverse sequence, checking that cylinder is fitted with locking pin to the right.
4. Adjust striker yoke on lid to secure good grip with lock and satisfactory fit against weather strip.

### REASSEMBLY

1. Press the catch pin 7 of the lock cylinder 6, and make the latter enter the sleeve 5. NOTE! This is possible only when the key is turned 35° clockwise.
2. Fit torsion spring 4 and housing 3. When doing this, make sure that the spring is inserted into the smallest of the recesses in the sleeve, and into the hole in the housing.
3. Fit retaining ring 2.
4. Install lock in car.

## FROM CHASSIS NO. 168.001

### DISASSEMBLY

1. Remove lock from car.
2. Make a picklock 1, dimensions see fig.
3. Remove retaining ring 2.
4. Remove Housing 3, and torsion spring 4.
5. Turn key 35° clockwise.
6. Insert picklock towards catch pin 7, and force — by turning the picklock — the catch pin to touch the cylinder.
7. Extract cylinder 6 out of lock.

## TAILGATE, SAAB 95

### ADJUSTMENT OF BALANCE SPRING TENSION

The tailgate on the Saab 95 is fitted with two balance springs, which are adjusted by means of a nut, see fig. To adjust a spring remove trim panel between tailgate and quarter window. Spring tension should be sufficient to lift tailgate right open from any position after opening.

### TAILGATE LOCK

The tailgate lock and outside handle with lock cylinder may be removed after the door interior trim is removed. Adjust the striker plate as for the front doors.

## GLASS AND INSTRUMENT PANEL GENERAL

All glass is toughened, or in the case of windshields for certain countries, laminated. For replacement only safety glass — toughened or laminated — should be used.

### REPLACEMENT OF WINDSHIELD

1. Remove windshield wiper arms.
2. Release rubber weather strip from body metalwork and press windshield by hand from inside the car.
3. Clean contact surface of weather strip on body, removing all traces of old sealer.
4. Fit a new weather strip to windshield glass. Be careful to locate weather-strip joint (sometimes marked with a yellow spot) at center of windshield lower edge.
5. Press trim molding deep into its groove, using the thumb, and fit molding junction clips.
6. Fit a leather thong in channel of rubber weather strip. Arrange thong ends at center of windshield lower edge.
7. Locate windshield in body opening, either with the aid of an assistant or by means of arrangement illustrated.
8. From inside vehicle, pull leather thong to draw edge of rubber weather strip over sheet-metal edge. Pull left and right sides alternately while the assistant presses glass from outside and works rubber strip with a rubber-headed hammer, exercising care, however.
9. Check that inside flange of weather-strip channel is inside metal edge right around windshield. Bump trim molding gently with rubber hammer to ensure that molding flange is deeply seated. Press junction clips in place.
10. Inject glass sealer both between weatherstrip and body and between weatherstrip and glass.

11. Clean away excess sealer from glass and paintwork, using kerosene or similar solvent and washing off afterwards with water.

### REPLACEMENT OF REAR WINDOW

The rear window may be replaced by the same method as the windshield. The rear shelf must first be removed, however.

### REPLACEMENT OF QUARTER WINDOWS

1. Press glass from inside outwards, simultaneously turning up inner flange of rubber channel. Commence from rear edge of glass.
2. Fit a new glass of prescribed quality in weather-strip. Place a leather thong in channel of weather strip with ends hanging at rear edge.
3. Pull glass and weatherstrip into position with leather thong as described for windshield. Commence at rear edge of glass.





## REPLACEMENT OF DOOR GLASS

The base of the door window glass is pressed into a retainer channel with a slot for the window-regulator link arm. At the front of the retainer channel a hinge is fitted and attached to the door frame by two screws. A run channel guides the rear edge of the glass.

### REMOVAL

1. Wind down window until rear edge is just below weather seal.
2. Back off both screws at hinge.
3. Twist glass to bring rear edge upwards and in towards car.
4. Extract glass as shown.
5. Release glass from retainer channel.

### INSTALLATION

Installation may be done without removing interior trim, as may removal of glass, but these operations are easier if the trim panels are taken out.

1. Fit rubber insert in retainer channel and press glass into channel. Check that retainer holds glass securely.
2. Lower glass at an angle from inside door, with hinge at bottom. Guide link-arm end into retainer slot.
3. Twist glass to bring hinge upwards to right location, simultaneously moving glass to rear so that it is guided by run channel.
4. Lightly tighten both hinge screws and wind up glass.
5. Adjust window at hinge to secure close fit in run channel without sacrificing smooth operation. Finally tighten hinge screws.

## REMOVAL AND INSTALLATION OF REGULATOR

1. Remove inside door handle, regulator crank and door trim panels.
2. Back off four screws accessible through holes in regulator toothed segment, holding window glass in position during this procedure.
3. Release link-arm end from retainer slot and remove regulator from car.

Follow reverse procedure to install window regulator.

## REMOVAL AND INSTALLATION OF INSTRUMENT PANEL

1. Remove end fairings by backing off sheet-metal screws and clips.
2. Release body panel attachment of brace at center of instrument panel.
3. Back off two fixing screws on each side, collecting rubber shims and washers, and pull away instrument panel.
4. Disconnect lead terminals, speedometer wire, ducts for defroster and windshield washer tubing.
5. Install in reverse sequence.

## REPLACEMENT OF INSTRUMENT PANEL OVERLAY

1. Remove instrument panel and disassemble instruments and glove compartment.
2. Release lower molding by removing clips at rear.
3. Release clips at upper edge, which may also retain defroster duct, and pull overlay pad from instrument panel.
4. When refitting apply adhesive only to projecting part of instrument panel and corresponding part of overlay pad, then press pad in position. See fig.
5. Next fit trim molding and clips and cut away part of pad projecting below molding. Do not, however, cut away part over opening for instrument cluster.
6. Fit instruments and glove compartment.

## FINISH

### GENERAL

#### ENAMEL

Saab cars are finished with a synthetic stoving enamel, which is based on alkyde resin, melamine resin, pigment and solvent. An epoxide-base binder is also included. The pigment is the constituent which gives the paint skin its color, body, toughness and covering power. The pigment must also protect the binder against ultra-violet light. The required colours are usually obtained by mixing several pigments. The solvent consists mainly of aromatic hydrocarbons (e.g. xylene), aliphatic hydrocarbons (e.g. gasoline) and alcohol. The melamines are usually dissolved in an alcohol, such as butyl alcohol. The solvent improves several desirable paint qualities, related to sprayability, drying time and flow characteristics.

#### UNDERSEAL COMPOSITION

The underbody of Saab cars is sealed at the factory, immediately after stoving of the primer. The underseal composition is hot-sprayed at approx. 140° F (60° C). It contains about 50 % synthetic





rubber varnish (asphaltic-bitumen based), 25 % filler (asbestos fiber) and 25 % solvent (aromatic hydrocarbon).

Minimum skin in wet condition is .054 in. (1.5 mm.), but at least .078 in. (2 mm.) is applied at parts suffering hard wear, such as under the fenders. The skin thickness is reduced by about 25 % on drying.

### THE SAAB BODY FINISHING PLANT

The body assembly passes through several finishing stages. Leaving the assembly line, it is carried by an overhead conveyor to a degreasing area, where grease accumulations are removed in a bath containing phosphoric acid and emulsifiers, mixed with a filler to a jelly-like consistence. The next process is phosphatizing, in six stages. Stages 1 to 3 comprise cleaning and rinsing, stage 4 phosphatizing by the zinc-phosphate method, and stages 5 and 6 rinsing and passivating. Passivating is carried out in water to which has been added phosphoric and chromic acids.

After drying and filling, the body passes through a 65-ft. (20 m.) drying oven at a temperature of 347° F. (175° C). Next, all body joints are closed with a body sealing compound consisting of rubber varnish, asbestos fiber, alkyde resin and aromatic hydrocarbons. After spirit washing and tack-ragging, the body is ready for the primer coat. Tack-ragging involves wiping of the body metal with a piece of muslin or cheesecloth soaked in slow-drying varnish. During priming the body is constantly moving, and the paint is stoved in a 75-ft. (23 m.) baking oven including both an infra-red zone and a convection zone. After cooling in a cold zone the underbody is

hot-sprayed at 140° F (60° C). The next stage is washing and flatting, with touching up of thin patches, in preparation for the application of color coats, before which the body is again dried, spirit washed and tack-ragged. The baking oven for stoving the finish enamel is 135 ft. (41 m.) long and also includes infra-red and convection zones. The body is subsequently cooled, inspected and transferred to the conveyor leading to the final assembly line, after any minor faults have been touched-up. The finish is again inspected after final assembly and cars on which any faults are noticed are sent to a touch-up bay for finished vehicles.

### TOUCH-UP AND REFINISH INSTRUCTIONS

#### GENERAL

For all touch-up or refinish jobs use synthetic stoving or air-dry enamel of the same make as the original finish. Cellulose or combination enamels are not recommended due to inferior characteristics in respect of toughness, gloss and colour retention, arising principally from the different binders used.

A basic requirement for good results is that the paintshop or bay is absolutely free from dust. It should also be free from drafts and not used as access to other departments. Keep the floor damp during spraying. A paint job spoilt by dust cannot be restored by polishing — wet flatting with 400 abrasive paper and respraying will be necessary.

This respray coat must be very thin. Before any partial refinishing is undertaken spray a test portion to check that the shade is identical with the original colour. If not, a little toning shade must be added to the paint.

The enamelling may be divided into the following stages:

- Removal of, for example, rust and old paint
- Flatting down
- Cleaning with a solvent
- Priming with, for example, wash primer
- Filling — where required
- Flatting
- Finishing coats
- Air-drying, drying under an infrared lamp or stoving in oven, depending upon the type of enamel used.

#### PRETREATMENT

If old finish shows defects such as cracking, abrasions or other faults, use a paint remover or flat down to bare metal. After removal of the old finish, degrease the metal with spirit or other grease solvent. A similar degreasing should also be carried out even if the old finish has not been removed but simply rubbed down. Bump or realign any deformed sheet metal and grind with a disc grinder, if necessary, before wet flatting with 220—240 abrasive paper. Finally, clean all parts again with spirit or thinner. Perfect cleanliness is vital for good adhesion.



### Priming

Prime all cleaned metal areas with synthetic primer, of the same make as the original paint. Normal drying time is about 45 minutes at 158° F (70° C), or 5–6 hours for air drying. An infra-red radiation dryer may also be used, but be careful to keep it at a distance of not less than 16 in. (40 cm.) from the metal. After drying, apply — as necessary — a coat of sealing compound, and allow correct drying between applications.

### RUBBING DOWN

Rub down the primed and filled surface with 320 mesh paper, then again with 400 paper, used wet. After removing all water wash the surfaces with spirit or thinner and pass over with a tack rag, i. e. a piece of muslin or cheesecloth soaked in slowdrying varnish.

### EQUIPMENT NEEDED, AND DESCRIPTION OF WORK, FOR REENAMELING

#### Stoving touch-up enamel

*Oven:* Convection oven with an air temperature of 194–212° F (90–100° C) — which gives to the plate to be enamelled a temperature of approx. 178° F (80° C) is required. An infrared oven may also be used, the temperature of the plate to be enamelled should in that case be kept at approx. 178° F (80° C). Essential is that the air temperature be uniform in the whole oven, and be checked at regular, short intervals. When checking the air temperature, use for example a calibrated maximum- and minimum-thermometer or a thermoelement with compensator. For checking the plate temperature only the latter can be used.

*Enamel:* to the stoving touch-up enamels of the AB Becker (the Becker Company) are to be added 20–25 % of hardening enamel. The stoving touch-up enamels of the Glasurit A/G (the Glasurit Works, Ltd.) already contain the hardener.

The enamel may be either hot-sprayed or cold-sprayed, the viscosity to be regulated with a synthetical thinner to the following values:

Hot-spray — viscosity approx. 35 seconds.

Cold-spray — viscosity approx. 21 seconds.

The viscosity to be measured with a beaker in accordance with the specifications in SIS 160011 (Swedish Standards Institute) at a temperature of approx. 68° F (20° C).

*Procedure:* First clean the body and the chassis carefully in order to prevent the formation of dust in the spray booth and in the oven. Disconnect the negative terminal of the battery, drain the fuel tank. The gasoline tank filler cap to be removed, and also the stop lights. All glass windows to be masked with paper in order to prevent the temperature inside the car from becoming too high. Prior to preparation and enamelling, see to it that the car has acquired room temperature.

When placing the car in the oven, the latter must have an air temperature of 194–212° F (90–100° C), as prescribed. After 1 hour, take out the car. It is essential that the air temperature inside the car not exceed 167° F (+75° C) and therefore all doors, windows and lids must be kept closed. If, for some reason, for example the rear lid or the hood cannot be kept shut, the space behind/inside must be masked.

#### Air-drying touch-up enamel 68-178 °C

which corresponds to 20–80° C.

The enamel is air-drying, and therefore no special arrangements are required, except for a well heated paintshop, free from dust. The drying time will, however, be highly reduced, if the enamel is dried under an infrared lamp, or stoved in an oven with an air temperature of maximum 178° F (+80° C).

The enamel may be either hot sprayed or cold sprayed, the viscosity to be regulated with a synthetical thinner to the following values:

Hot-spray — viscosity approx. 35 seconds.

Cold-spray — viscosity approx. 21 seconds.

The viscosity to be measured with a beaker in accordance with the specifications in SIS 160011 (Swedish Standards Institute) at a temperature of approx. 68° F (20° C).

Before preparation and enamelling the plate shall have acquired air temperature.

#### NOTE!

There may be different makes of the same color. Therefore, when ordering a touch-up enamel always state: chassis No. and color.

### GENERAL MAINTENANCE

Correct maintenance is necessary to retain the gloss and durability of the finish, and the protection afforded by the underseal.

### WASHING

Wash a new car frequently: this hardens the enamel, improves its toughness and helps retain gloss. Use only water, as additives tend to dry out the enamel. However, if water does not suffice, a weak (not more than 2 %) soap solution may be employed, but take great care to remove all traces of the solution from the car after washing, by generous use of fresh water and careful sponging. Never wash the car in strong sunshine, and always dry the finish with a clean chamois leather. Lime in ordinary water causes patchiness if the car is allowed to dry naturally in sunlight.



## POLISHING

Generally speaking, synthetic enamels should not be polished until absolutely necessary. In any case, never polish the enamel until it has hardened, which takes 5 to 6 months. Polishing is intended to restore the appearance of the finish and to provide the enamel with fats to prevent drying-out and cracking. Never polish a new vehicle with an abrasive agent—such treatment should not be necessary until after several years, to remove oxidation products and suchlike from the finish. Always clean the car thoroughly before any form of polishing is undertaken, otherwise scratches will be caused.

## WAXING

The car should be waxed after polishing. As with polishing, a new car should not be waxed during the first 5—6 months of its life. Apply wax to small areas at each stage, and polish well afterwards to ensure that no accumulations remain.

## TOUCHING-UP OF UNDERSEAL

To retain the protection afforded by underseal composition, the underbody finish should be inspected regularly and touched up as necessary. Apart from corrosion protection, the underseal aids sound insulation. The protection given is especially important to protect the fenders from the constant barrage of stones and gravel striking them. Before repairing worn or damaged areas in the underseal, clean the metal thoroughly with a scraper and steel-wire brush, followed by washing with gasoline. Do not apply an excessive amount of new composition, as it will tend to run and may pull right away after drying. Always treat new metal panels, such as fenders, after fitting. If underseal is applied prior to spraying, check that all composition is removed from surfaces which are to be colour painted.

## DESCRIPTION

### GENERAL

The interior fitments of a Saab car comprise, apart from seats, trim panels and mats (retained by spring clips) and the headlining, which is stretched on piano-wire bows and retained by wire spirals along the roof rails. Due to the simplicity of the retaining devices all parts are easy to remove.

The Saab 95 and 96 models are fitted out

identically except as regards rear seat cushions, headlining and mats to the rear of the center pillars. Fitments in the GT 750, on the other hand, differ considerably from those in the other models and only the headlining, front wheelhouse mats and trim of the cowl plate are inter exchangeable.

## SEATS

### GENERAL

#### FRONT SEATS

The individual front seats are manufactured of sprung steel tube with foam-rubber cushions and coverings fixed on transverse coil springs. Seats may be adjusted for legroom and fixed in the desired position by an easily accessible, spring-loaded latch. The slope of the seat back may be altered by means of the lever located between the seat and the door. From chassis No. 168.001 the front seats are fitted with wooden, wedge-shaped spacers, enabling a higher sitting position. These inserts can be fitted in older models, too. A strong safety latch fitted at the rear left side of the passenger seat prevents the seat back being jack-knifed during sudden braking. Seats in the GT 750 are more comfortable, and the backs may be dropped fully to the rear. The passenger seat is also equipped with a headrest.

#### REAR SEAT

The seat cushion and back are, in the Saab 96, comprised of a frame retaining coil springs, with stuffing and covering material. The base is, in both cushion and back, a sheet of plywood. The seat cushion is loose, being located by the floor transverse member at the cushion front edge. The seat back rests at its base on two brackets attached to the inclined transverse panel, and is also secured at its upper edge to prevent displacement of objects in the rear compartment in the event of sudden braking. An arrangement (illustrated) under the rear seat cushion permits adjustment of seat height.

The two rear seats in the Saab 95 are of foam rubber on a firm base, which also serves as luggage deck when the seats are dropped. The rear seat of the GT 750 is intended as an occasional seat, with loose cushions and storage space under.

### REMOVAL OF FRONT SEATS

1. Lift up or remove rear-seat cushion.
2. Depress seat-adjustment handle and push seat right back until clear of floor rails, after which it may be removed.

Inspect the seat floor rails now and then, checking that fixing bolts are tightened and that the rails are not displaced to the side. If seats are stiff, grease the upper rail flanges.





## CLEANING UPHOLSTERY COVERS

Whenever attempting to remove stains from fabrics of any kind it is recommended that the area adjacent to the stain first be moistened with cleaning fluid, before working on the stain itself. If this is not done, a soil ring may be left around the cleaned spot.

### SPECIFIC STAINS

Remove grease, oil or lipstick with carbon-tetrachloride. Large stains may best be dealt with by first moistening the surrounding area, then pouring cleaning fluid over the entire stain and soaking it up with blotting paper.

Chocolate, ice-cream, fruit and nausea stains should first be treated with lukewarm water, possibly with the addition of a little soap solution. After drying, any remaining stains may be removed with carbon-tetrachloride.

Treat battery acid instantly with large quantities of cold water, if possible with the addition of a little household ammonia, during the first moment. Failure to take quick action can lead to acid burns in the cloth.

Never allow blood spots to dry, but remove them at once with cold water. If the spot leaves a slight stain, carry out further treatment with lukewarm soap solution.

### UNIDENTIFIED STAINS

Try the following cleaning media in the order named:

- Cold or lukewarm water
- Lukewarm soap solution

Before proceeding further, remove soap solution with lukewarm water and let the material dry, since the following cleaning fluids do not mix with water.

- Carbon-tetrachloride
- Trichlorethylene
- Pure gasoline

Rub the spot as the cleaning fluid evaporates, first fairly hard, but progressively more gently as the evaporation continues. Do not omit the initial moistening around the stain area. The bigger the stain, the bigger the area to be moistened. Lighter fuel may be used instead of carbon-tetrachloride.

### CLEANING PLASTIC-FACED FABRICS

Plastic-faced fabrics do not allow dirt to pass through, since they are dust tight and proof against oil and gasoline. A dirty plastic surface may be simply cleaned by washing with water and a synthetic detergent. White spirit, trichlorethylene, etc., may be used to remove more serious oil or other stains. Do not use chemical cleaners too frequently, however, as the plastic may become stiff.

## TRIM AND MATS

### GENERAL

#### DOOR AND SIDE TRIM

Door and side trim panels comprise covering over cardboard foundation, and are fixed in place with spring clips of conventional type. The panels may be easily removed for replacement or inspection purposes.

#### COWL PLATE TRIM PANEL

The cowl plate trim panel is also of cardboard and is secured to the cowl plate by sheet-metal screws and spring clips. A thick glassfiber quilt between the trim and the cowl plate proper provides sound and heat insulation.

#### MATS

Both front and rear mats are fixed to the floor panel by spring clips. Rubber mats at the front sides are glued in place on the wheelhouses.

#### HEADLINING CHASSIS UP TO 168.000 (THE 96 MODEL) AND 6.623 (THE 95 MODEL)

The headlining is provided with a number of piano-wire bows retaining the cloth close to the roof panel. At the front the lining is fixed by hooks in the steel channel section running round the roof interior, while at the sides it is tensioned to the roof rails by wire spirals.

#### REMOVAL AND INSTALLATION OF ROOF LINING UP TO CHASSIS 168.000 (THE 96 MODEL) AND 6.623 (THE 95 MODEL)

In the Saab 96 and GT 750 the twin wire spirals tensioning the headlining are secured to a hole in the rear compartment. In the Saab 95 they are secured under the garnish panel at the tailgate pillar.

1. Remove rubber plug from hole, or garnish panel, and attach a steel wire to each wire spiral on both sides (this will facilitate refitting).
2. Release wire spirals from around rear window and take down headlining bow by bow, starting from rear.
3. Finally, unhook lining from three clips at windscreen upper side.
4. Refit in reverse sequence. In the Saab 96 and GT 750, pull down and secure wire spirals as illustrated, checking that rubber molding between body panels (above air extract) is not displaced.

#### NOTE

Only the new type of headlining with a running-around wire spiral is kept as a spare part for the Saab 96. Therefore, when replacing the headlining on older cars two self-tapping screws must be fitted for the fastening.





### HEADLINING FOR THE SAAB 96 FROM CHASSIS NO. 168.001 FITTING AND REMOVAL

Beginning with the chassis No. mentioned above the fastening of the headlining has been altered. Before, the fastening was made with 2 wire spirals, drawn into the luggage compartment — now, instead, a wire spiral running round the headlining is used.

From now on only the latter type will be kept as a spare part. Therefore, the fastening will have to be altered in older cars. This is done by drilling 2 holes for self-tapping screws, which shall be placed — one on either side — between rear window and side window, in the inner roof channel section, see figure.

When fitting the headlining, first fasten it to the three front hooks in the windshield frame. Then mount the transversal bows backwards, with the bows lying. In older cars the lining shall be fitted at the back, to the two self-tapping screws. In later cars there are brackets welded-on at the corresponding points. For the fitting of the headlining a special tool 784096 is required. See chapter 20. After removal of the back seat, put the hook of the tool into the opening at the back and hook it upper corner of the back rest, see fig. Then, with the aid of the tool, fit the headlining backwards and hook it beneath brackets or to the self-tapping screws respectively. Finally, stretch the lining by raising the bows; if, when stretched, the headlining is not completely smooth, this may be remedied by gentle heating with an infrared lamp (of the type used for touching-up the paint-work).

**NOTE!** If overheated, the plastic will melt and become shiny.

Removal of the headlining is made in reverse order, take care so that the lining does not crack.

### HEADLINING FOR THE SAAB 95 FROM CHASSIS NO. 6.624

Beginning with the chassis No. mentioned above the fastening of the headlining has been altered. Before, the fastening was made with 2 wire spirals, which were stretched backwards — now, instead, a running-around spiral is used.

When fitting, first fasten the lining's front edge to the three hooks located in the upper part of the windshield frame. Then stretch the lining backwards, mounting the bows. With the aid of special tool 784096, then fasten the headlining over three hooks. Finally, fit the longitudinal wire spirals. These are divided in the middle, and have hooks. With the aid of two steel wires, bent double, the hooks are caught and then hooked together.

Removal in reverse order.

### SUN ROOF

#### GENERAL

The sun roof consists of outer and inner fabrics on a series of steel bars, and a tensioning device.

The steel bars slide in channels screwed onto a wooden frame, which is secured to the roof panel.

### REMOVAL AND INSTALLATION OF OUTER FABRIC

1. Open sun roof halfway, pass one hand under fabric and remove both front retaining bolts with a screw-driver.
2. Turn back fabric little by little as it is released from ribs, to which it is attached by clips.
3. Pull away cover strip from rear attachment and remove screws and strip holding outer fabric close to body panel.
4. Install in reverse sequence.

### REMOVAL AND INSTALLATION OF INNER FABRIC, WITH RIBS AND LOCK

1. After removing outer fabric remove both short channel pieces at rear.
2. Release fabric at rear edge, where it is nailed to wooden frame.
3. Pass inner fabric together with ribs in a rearwards direction and remove from car.
4. If fabric is to be replaced, release it from ribs and from glued attachment to locking device.
5. Install in reverse sequence.

The headlining is tensioned at its edges with wire spirals, as on standard models. The lining is glued and nailed to the wooden frame of the sun roof.

### ADJUSTMENTS

#### TENSIONING OF OUTER FABRIC

If the outer fabric requires tensioning, it must be fully removed. After separation from the rear strip, the strip can be shifted as much as deemed necessary and the fabric glued to the strip, before reinstallation.

#### ADJUSTMENT OF LOCKING DEVICE

The locking device can be adjusted laterally to ensure correct travel in the side channels. There are three adjustment screws on each side.

#### ADJUSTMENT OF RIBS

Two of the ribs may be adjusted laterally, the screws being located under the rib, as illustrated.

### MAINTENANCE OF FABRICS

The outer fabric is Convertex plastic-impregnated material, which only requires regular washing. Special detergents intended for the Saab sun roof are available under the names "Happich-Frischdienst" and "Synclean".

The outer fabric must never be cleaned with such solvents as trichlorethylene, carbon-tetrachloride, or similar. These fluids will ruin the facing and allow dirt to penetrate into the body of the plastic. The roof will then be impossible to clean properly and will also lose its suppleness.



LUBRICATION CHART SAAB 95

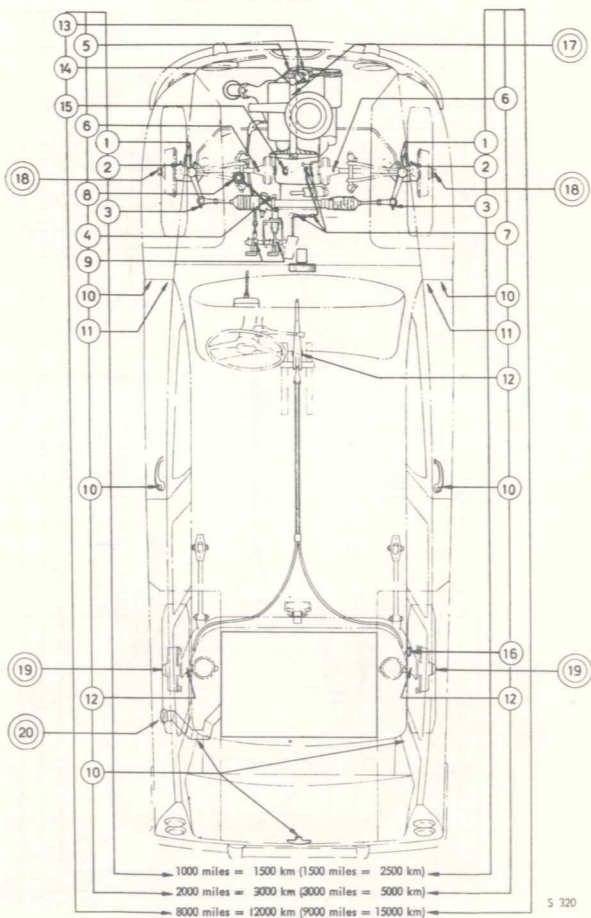

The figures in brackets refer to year model 1964.  
The Encircled numbers refer to lubrication chart.



### LUBRICATION CHART SAAB 96 AND GT 750

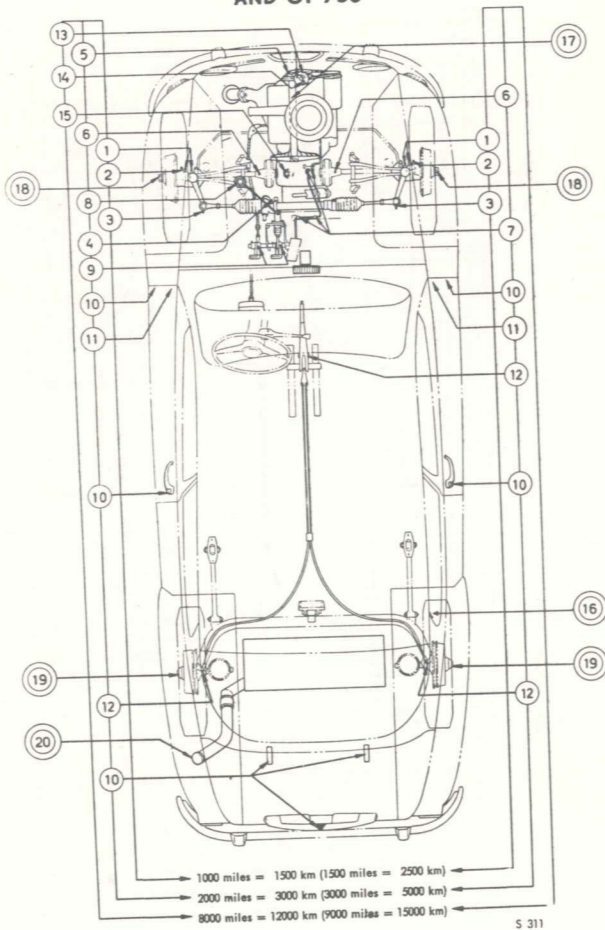

The figures in brackets refer to year model 1964.  
The Encircled numbers refer to lubrication chart.



## LUBRICATION CHART FOR SAAB 95 AND 96

Lubrication intervals *		Index	Lubrication points	Number		
X			Upper & lower ball joints, L & R	4	Universal or chassis grease	Grease gun
X		1	Drive shaft, outer joint, L & R	2	"	"
X	X	2	Drag rod ends	2	"	"
	X	3	Steering gear	1	"	"
		4			Alt. non-freezing lubricants. For extremely cold weather, SAE 40 can be used as an additive.	
	X	5	Distributor gear	1	Universal or chassis grease	Oil can
	X	6	Inner drive shafts	2	"	"
	X	7	Accelerator	5	"	"
	X	8	Hydraulic brake system	1	Brake fluid SAE 70 R 3	Top-up
	X	9	Pedals and clutch cable	4	Oil SAE 40	Oil can
	X	10	Hinges and locks	9	"	"
	X	11	Door stops	3	Vaseline	Grease
	X	12	Handbrake links	3	Oil SAE 40	Oil can
	X	13	Distributor shaft	2	"	"
	X	14	Distributor cam	1	Bosch Ft. 1 v 4	Grease felt
	X	15	Gear box	1	EP-oil SAE 80	Check oil level
	X		Gear box	1	"	Oil change 1.4 lit. (3 US pints). First change at 600 —900 miles (1000—1500 km).
	X	16	Latch, rear side window Shock absorbers, rear	2 2	Universal or chassis grease Shock absorber fluid	Grease Check
Approx. 32000 miles (Garage (Approx. 50000 km) service)		17	Fan shaft bearings	2	Universal or chassis grease	Re-pack
		18	Front wheel bearings	2	"	"
		19	Rear wheel bearings	2	"	"
When fueling		20	Engine	1	Two-stroke oil Motor oil of Premium- and HD types (ML, MM and MS) may also be used. Viscosity preferably SAE 40, but not less than SAE 30.	Mix 3 % oil in fuel (1:33 mixture). NOTE: Higher percentage of oil for self-mixing two- stroke oil. NOTE: At temperatures consistently below 23° F (—5° C) the oil should be mixed with, at least, an equal quantity of gaso- line before being poured into the tank.

\* For the 1964 year model  
these figures are:



**LUBRICATION FOR SAAB GT 750**

The GT 750 should be lubricated in conformity with the table for the Saab 95 and 96 with the following exception:

Ref. 20	Engine	Use 4 % (1: 25) admixture
---------	--------	---------------------------

**1,000-MILE (1,500 Km.) LUBRICATION**

For the 1964 model 2500 km (1500 miles)

**1. BALL JOINTS, SUSPENSION ARMS**

Jack up front end to lift wheels clear of floor when greasing ball joints. Twist each wheel in turn to full lock to permit easy access to ball joints and outer drive-shaft joints.

**2. OUTER UNIVERSAL JOINTS**

During lubrication check that rubber bellows enclosing joint is not abnormally distended. A damaged bellow, from which grease might escape, must be replaced immediately, the joint being cleaned and lubricated with fresh grease. Grease nipples are located on leading side of steering knuckle, and are more easily reached if front is jacked up. Massage bellows to force grease into joint.

**3. TIE-ROD ENDS**

Check that rubber bellows is not abnormally distended and that they are free from defects likely to cause loss of grease. Replace a defective bellow without delay. Tie-rod end grease nipples are more easily reached if front end is jacked up and wheels turned full lock towards opposite side.

**4. STEERING GEAR**

Avoid excessive lubrication of the steering gear. Check that rubber bellows are not abnormally distended after lubrication and are free from defects. Replace defective parts immediately.

**NOTE**

Use cold-resistant grease for the steering gear during winter weather, ensuring perfect functioning despite low temperatures.

Failure to use cold-weather lubricant over a prolonged period (two or three service intervals) may result in difficulties at very low temperatures. In such case, add SAE 40 oil to dilute lubricant in steering gear.

**2,000-MILE (3,000 Km.) LUBRICATION**

For the 1964 model (5000 km 3000 miles)

**5. DISTRIBUTOR GEAR**

A grease nipple is located on left side of engine immediately to rear of crankshaft pulley. As new grease is injected remove old grease exuded from plastic tube.

**6. INNER DRIVE SHAFTS**

Lubricate splines of inner drive shafts through holes in outer carrier of inner universal joints.

**7. THROTTLE LINKAGE**

All bearing and linkage points are accessible from engine compartment. If roller under gas pedal causes troublesome noise, remove bolt and grease lightly.

**8. BRAKE SYSTEM**

See that brake-fluid reservoir is well filled at all times. Check fluid level every 2,000 miles (3,000 km.) and after bleeding of hydraulic system. Also check that vent hole in cap is not choked. Use only brake fluids specified in lubrication table.

**9. PEDALS AND CLUTCH CABLE**

Lubrication of brake and clutch pedals comprises two points on pedal shaft and one at connection of master cylinder pushrod. Lubricate clutch cable at guide pulley, locating pin and inner wire.

**10. HINGES, LOCKS, DOOR CHECKS AND FREEWHEEL CONTROL**

Lubrication points comprise: four door hinges, two door locks with striking plates, two door checks, two rear lid hinges, one rear lid support and one lid lock. Use cold-resistant lubricant for locks, and a lubricant not harmful to clothes for door checks and striking plates. Lubricate freewheel control at cowl plate. Special lubrication fittings, comprising a rubber plug with a through hole, are provided for door hinges. Press oil can against plug while injecting lubricant.

**11. DOOR STOPS**

The door stops should be greased with a lubricant that does not soil your cloth. For example: Vaseline.

**12. HANDBRAKE LINKAGE**

There is a link inside of each rear-wheel brake plate and also at the handbrake lever. The lever ratchet should also be lubricated.

**8,000-MILE (12,000 Km.) LUBRICATION**

For the 1964 model 15000 km (9000 miles)

**13. DISTRIBUTOR SHAFT**

Lubricate by filling the grease cup located on leading side of distributor housing. Also remove distributor rotor and soak felt wick fitted in shaft upper end, below rotor.

**14. BREAKER CAM ASSY.**

Lubricate by soaking felt wick and greasing cam itself.

**NOTE**

Avoid excessive lubrication of distributor parts, as grease on breaker points will cause burning of these.

**15. TRANSMISSION**

Transmission case and differential are filled and drained through the same openings. Check oil level every 2,000 miles (3,000 km.) by unscrewing level-control plug and inserting a wire. If level is more than 1/5 in. (5 mm.) below plug opening, add further oil until it flows from level-control opening. When an oil change is to be made, run engine for 15—20 minutes prior to draining old oil. Flush transmission case before filling with fresh oil until oil runs from level opening. Together, the transmission case and differential contain 2 1/2 pints (1.4 liters).

**NOTE**

Never mix different types of oil.

Make the first oil change after 1,500—2,000 miles (2,500—3,000 km.) and thereafter change transmission-case oil every 8,000 miles (12,000 km.), or alternatively every spring and fall.

**Rear shock absorbers, Saab 95**

The filler plugs of the rear shock absorbers on the Saab 95 must be regularly opened for checking of oil content and refilling as required.

**16. SIDE WINDOW LATCH:** to be greased**AT APPROX. 30,000 MILES (50,000 Km.) OR DURING RECONDITIONING****17. RADIATOR FAN SHAFT BEARINGS**

The fan shaft bearings can most conveniently be repacked with grease during engine reconditioning, when the parts will be disassembled for inspection. If fan-shaft bearing stand only is to be

lubricated, remove bracket from engine and disassemble fan and pulley. Remove all old grease, and check bearings and seals.

- If a bearing requires changing, retainer and seals at both ends of tube must first be removed, after which shaft may be pressed out towards pulley end. See Chapter 8. Remove all old grease from tube and repack with fresh before reassembly.
- If no parts require replacement, simply remove fan, pulley and seals. Pack ball bearings with grease from outside Refit seals, fan, and pulley.

**18. FRONT WHEEL BEARINGS**

Each front wheel is borne in a double-row ball bearing. These bearings are repacked with grease as follows:

- Clean thoroughly under fenders before commencing disassembly to avoid risk of dirt dropping into bearings.
- Back off wheel bolts and remove nut from drive-shaft end after driving out cotter pin.
- Jack up car and remove wheel.
- Remove hub with help of hub puller tool, No. 784002.
- Clean and wash all accessible parts. Remove old grease.
- Replace any damaged parts — check especially that shaft seals are free from defects. See Chapter 9.
- Pack new grease in bearings, from outside. Job will be simplified if drive shaft is rotated simultaneously.
- Inspect contact surface against outer shaft seal for possible damage. Grease contact surface and refit wheel hub. Check that both Woodruff keys are in shaft and have not been displaced by hub.
- Fit castle nut and torque. Refit wheel. Secure

**19. REAR WHEEL BEARINGS**

Each rear wheel is carried in two ball bearings, and these must be removed for regreasing. Proceed as follows:

- Jack up car and remove wheel. Clean all dirt and sand from inside of fender. Remove dust cap from over axle nut, using a screwdriver.
- Drive out cotter pin and back off axle nut.
- Check that handbrake is fully released, and relieve brake adjustment screws.
- Pull off wheel hub with tool No. 784002.
- Continue according to instructions in Chapter 10. Pack ball bearings with fresh grease.



6. Refit ball bearings, spacer and seal
7. Fill wheel hub with sufficient grease to occupy half of space between bearings.

## NOTE

Use only enough grease to fill half of space. Excessive filling may lead to grease entering the brake drum and spoiling the linings.

8. Check that rear axle surface intended to provide a shaft seal is free from defects. Grease this surface with ball-bearing grease.
9. Refit hub, torque, and secure with a cotter pin. Replace dust cap, using tool No. 784036.
10. Refit wheel and lower car to floor. Tighten wheel bolts.
11. Adjust brakes.

## WHEN REFILLING FUEL TANK

## 20. ENGINE

The engine is lubricated by oil mixed with the gasoline. It is important to use a good-quality oil of the correct viscosity. Follow the recommendations in the lubrication table and check that the right mixture proportions are always used. Whenever possible, use two-stroke oil in the fuel; but if this is not available, normal four-stroke oils of Premium and Heavy-Duty grades (ML MM and MS in accordance with the API ratings) will be acceptable providing the viscosity is at least SAE 30.

Regular-grade gasoline with an octane number above 85 is recommended for the Saab 95 and 96; premium fuels can be used without any special disadvantage but no appreciable gain will result.

Premium-grade gasoline with an octane number

lubricated, remove bracket from engine and disassemble fan and pulley. Remove all old grease, and check bearings and seals.

- a. If a bearing requires changing, retainer and seals at both ends of tube must first be removed, after which shaft may be pressed out towards pulley end. See Chapter 8. Remove all old grease from tube and repack with fresh before reassembly.
- b. If no parts require replacement, simply remove fan, pulley and seals. Pack ball bearings with grease from outside. Refit

## OTHER LUBRICATION POINTS

## GENERAL

Apart from the lubrication points mentioned in the chart, certain other points may require attention at intervals, and should be inspected during overhauls.

## MIXING TABLE:

2-stroke oil SAE 30—40 or normal 4-stroke oil of Premium- or HD type, min. SAE 30	Self-mixing 2-stroke oil
<i>Saab 95 and 96</i>	
3 % = 1:33	4 % = 1:25
<i>GT 750</i>	
4 % = 1:25	5 % = 1:20

## LAYING UP

If the car is to be laid up for a long period, as during the winter months, it should first be greased. The engine should also be treated to prevent internal rust damage, as follows:

1. Remove cover and element from air cleaner.
2. Start engine and run it at fairly high revs. — 3,000—3,500 r.p.m.
3. Pour a suitable corrosion inhibitor (or motor oil, SAE 40 or SAE 50) into the induction pipe and allow the engine to continue drawing in oil

## 17. RADIATOR FAN SHAFT BEARINGS

The fan shaft bearings can most conveniently be repacked with grease during engine reconditioning, when the parts will be disassembled for inspection. If fan-shaft bearing stand only is to be until it stops itself. About 1/3 pint (2 deciliters) of oil will be needed. Note that the throttle must be kept at the same setting until the engine has stopped.

4. Switch off ignition. Refit air cleaner. After this treatment the engine should not be restarted until the car is put into service again next season. If there is risk of freezing drain the cooling system and remove the battery from the car. Keep the battery at room temperature in well-charged condition.





## 1. RADIO INSTALLATION

### INSTALLATION

In the Saab 95 and 96 a radio can most conveniently be fitted in the glove compartment.

The removable panel in the compartment lid should be taken out and the radio installed so that its dial and controls are accessible through the lid opening. The width of the pocket is reduced by cutting and bending up the lining cardboard, leaving space for the radio at the left.

In the GT 750 a detachable panel at the left end of the instrument panel may be removed to provide a suitable installation position for a radio.

### INTERFERENCE SUPPRESSION

#### GENERAL

The following measures are recommended for Saab 93, 95, 96 and GT 750 models, on the basis of experience hitherto gained in respect of interference.

In some cases it will be sufficient simply to suppress interference from the ignition system (degree of interference 1 in table overleaf). But reception conditions and other factors may make further measures necessary, as described against degrees 2 and 3 in the table.

Saab 96 and GT 750 cars from chassis No. 143700 and Saab 95 cars from chassis No. 4010 have a factory-fitted resistance in the ignition system, and the distributor on these cars need not be fitted with any further suppression. In many cases, it will not even be necessary to fit special spark-plug suppression. Refer to the table.

The total damping resistance for distributor and plugs combined must not exceed 20,000 ohms, otherwise the strength of the spark will be reduced. Check this if poor running is experienced. For good suppression it is necessary to have close electrical contact between the various parts of the body, especially round the engine. Use multiple-wire flat conductor with big area for ground leads. Do not fit ground leads at too many places in the body, but rather run them to the battery minus lead.

#### LOCATION OF ANTENNA

Locate the antenna as high and as far from the ignition system as possible. Thus, it may advantageously be fitted at the rear of the car, for example, on the ventilation cover in the case of the Saab 96. If fitted at the front end, place the antenna on the left fender as close to the door as possible. The supplier of the radio will usually be able to suggest a suitable conductor.

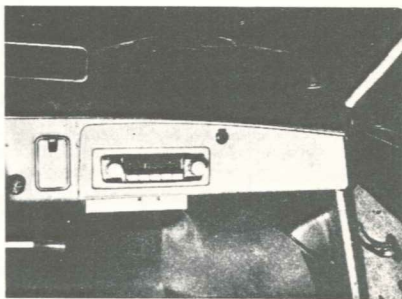

Radio installation

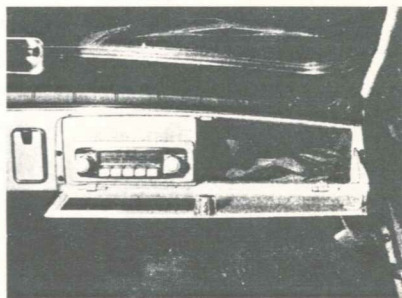

Glove compartment

#### SUPPRESSION FOR CAR FITTED WITH TRANSMITTER

If the car is fitted with a transmitter/receiver set particularly good suppression will be required, in accordance with the foregoing instructions and the following.

1. Pay special attention to achieving good contact between body panels, such as fenders, hood and main body assy.
2. In some cases it will be necessary to screen the ignition system, this being achieved by fitting a special screening device to the distributor and braided sleeves to the ignition cables, these being grounded.
3. Antenna location is important and the manufacturer's instructions should be regarded.





## SUPPRESSION MEASURES

Degree of necessity	Location	Description	Bosch designation
1	Distributor	<i>Alt. I:</i> Distributor rotor with integral resistance, 5,000 ohms.	ZVVT 9Z3
		<i>Alt. II:</i> 5,000-ohm resistance fitted in distributor cover center terminal	EM/W 5/20
		<i>Alt. III:</i> Resistance lead between ignition coil, distributor, spark plugs <i>Note:</i> If a resistance lead is used it will often be unnecessary to suppress plugs; but if this measure is required, employ alt. II for plugs.	Ignition cable with resist. 10,000 ohm/meter
		<i>Note:</i> When fitting any of alt. I, II or III increase spark plug electrode gap to 0.8 mm. instead of normal 0.7 mm. (.031 in. instead of .027 in.)	
1	Spark plugs	<i>Alt. I</i> Use plugs with integral resistance, 5,000 ohms per plug.	M 225 RT 1
		<i>Alt. II</i> Screened terminal plug with integral wire-wound resistance, 1,000 ohms	EM/WFR 1/2
		<i>Alt. III</i> Unscreened terminal with integral resistance, 10,000 ohms.	EM/W 10/11
2	Fuel pump	Condenser, 0.45 mfd. between input lead and ground	EMKO 19Z3Z
2	Generator	Condenser, 0.5 mfd. between connection D+ and ground connection D-	EMKO 15Z10Z
2	Voltage regulator (relay)	Condenser, 2.5 mfd., between connection B+ (51) and ground	EMKO 15Z12Z
2	Ignition switch	Condenser, 3 mfd. between input lead and ground	EMKO 9Z18Z
2	Hood	Multiple braided ground lead between grill, blind guard, hood and ground lead. Connect to ground at rear of hood by first ensuring good contact between hood lock arm and latch; fit ground braid between hood lock, and battery minus lead at ignition coil fixing bolt.	
3	Road wheels	In certain cases further suppression may be required in the form of a lead between wheels (rear, especially) and ground. This may be done by fitting a suitable coil spring between grease fitting and stub axle.	



#### 4. DISABLED-DRIVER CONTROLS

##### GENERAL

The Saab can be supplied with special controls permitting driving with hands only, but which still permits the use of the car for normal driving without any dismantling being necessary.

On a car fitted with a SAXOMAT clutch the following extra items are installed:

1. Hand lever control for footbrakes
2. Hand throttle control at steering wheel
3. Dimmer switch on instrument panel

A car fitted with the standard clutch will also require:

4. Hand clutch control and linkage to regular clutch pedal.

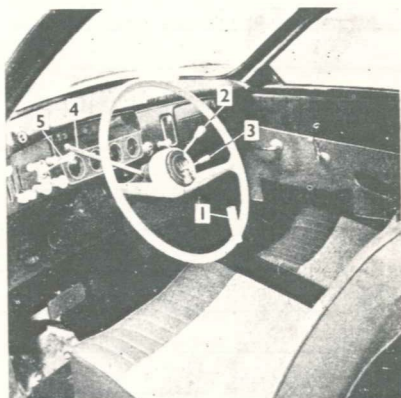

Disabled-driver controls, car with Saxomat clutch

1. Brake lever
2. Gear-shift lever
3. Turn indicator switch
4. Throttle (accelerator)
5. Dip switch

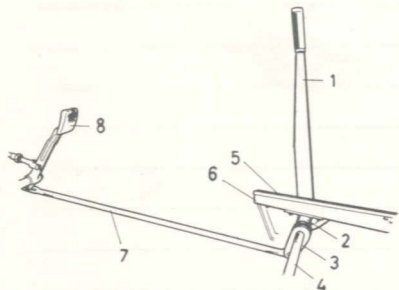

Footbrake control

1. Brake lever
2. Bearing
3. Link
4. Lever shaft
5. Seat rail
6. Chock
7. Pullrod
8. Foot pedal



Clutch control, car with standard clutch





## Technical data

## SPECIFICATIONS

## GENERAL DATA

Cylinder volume .....	841 cc (51.9 cu. in.)
Brake horse power DIN .....	52 at 5000 rpm
Torque DIN .....	9.5 kpm at 3500 rpm
Cylinder bore .....	70 mm (2.76 in.)
Stroke .....	72.9 mm (2.87 in.)
Compression ratio .....	9:1
Firing order (1=rear cyl.) .....	1—2—3

## Piston diameter, oversize:

ØD 0.5 A .....	70.409—70.416
ØD 0.5 B .....	70.416—70.423
ØD 1.0 A .....	70.909—70.916
ØD 1.0 B .....	70.916—70.923

Piston diameter measured at 90° to the piston pin, 15 mm from the lower edge of the piston.

## MEASUREMENTS AND TOLERANCES

## All measurements in mm.

## Cylinder bore, standard:

Class A .....	69.987—69.994
" AB .....	69.994—70.001
" B .....	70.001—70.008
" C .....	70.036—70.046

## Cylinder bore, oversize:

ØD 0.5 A .....	70.501—70.508
ØD 0.5 B .....	70.508—70.515
ØD 1.0 A .....	71.001—71.008
ØD 1.0 B .....	71.008—71.015

## Piston diameter, standard:

Class A .....	69.895—69.902
" AB .....	69.902—69.909
" B .....	69.909—69.916
" C .....	69.944—69.951

Piston clearance .....

0.085—0.099  
Approx. max. clearance between piston and cylinder through wear .....

0.15

## Out-of-round piston:

Difference parallel and at 90° to the piston pin, measured 15 mm from the lower edge of the piston .....

0.08—0.10

## Piston ring width:

Upper rings .....	2.478—2.490
Lower ring .....	1.978—1.990

## Piston ring clearance in groove:

Upper ring .....	0.08—0.11
Middle ring .....	0.07—0.10
Lower ring .....	0.06—0.09

Piston pin diameter .....

18

## Connecting rod, axial clearance:

Big end .....	2.05—2.32
Small end .....	0.1—0.4

Big end bearing, radial clearance .....

0.015—0.020

Small end bearing, radial clearance .....

The piston pin should fit with finger-tip pressure. It should be possible to rotate it with two fingers.

## Crankshaft, radial play

Max play permissible at the inner bearings with the crankshaft running on the outer bearings .....

0.05

## Compression (new engine)

Measured at an engine temperature of 80° C with fully open throttle and at full starting motor speed .....

9 ± 0.5 kp/sq. cm. (130 ± 7 lbs. sq.in.)







### SPECIFICATIONS

Front shock absorbers, length .....	250 mm (9 <sup>3</sup> / <sub>4</sub> in.) (extended 370 mm 14 <sup>1</sup> / <sub>2</sub> in.)
Front shock absorbers, compression, installed .....	82 mm (3 <sup>1</sup> / <sub>4</sub> in.)
Front coil springs, number of coils (material diameter 11.7 mm) .....	11 coils
Front coil spring, length .....	380 mm (15 in.)
Maximum spring depression, front .....	140 mm (5 <sup>1</sup> / <sub>2</sub> in.)
Front wheel angles, unloaded car:	
King pin inclination .....	7° ± 1°
Caster .....	2° ± 1/2°
Camber .....	3/4° ± 1/4°
Toe-in, measured on rim .....	2 mm ± 1 (0.08 ± 0.04 in.)
Turn angle:	
Outer wheel .....	20°
Inner wheel .....	22 <sup>1</sup> / <sub>2</sub> ° ± 1 <sup>1</sup> / <sub>2</sub> °

### TIGHTENING TORQUES

Castellated nut, front wheel hubs .....	18 kpm (130 lbs./ft.)
---	--------------------------

## BRAKE SYSTEM

### SPECIFICATIONS

#### GENERAL

Manufacture .....	.....
Type, front .....	.....
Type, rear .....	.....
Footbrake .....	.....
Handbrake .....	.....

#### DIMENSIONS, ETC.

Brake disc, front .....	.....
Brake drum, rear .....	.....
Master cylinder .....	.....
Wheel brake cylinder, front .....	.....
Wheel brake cylinder, rear .....	.....
Brake shoes, rear .....	.....
Brake hoses, front .....	.....
Brake hoses, rear .....	.....
Brake line, reservoir/master cylinder .....	.....
Other brake lines .....	.....
Brake fluid .....	.....

<b>Type II chassis —201.400</b>	<b>Type III Chassis 201.401—</b>
Lockheed	Lockheed
Disc brake	Disc brake
Drum brake, one leading shoe	Drum brake, one leading shoe
Hydraulic two-circuit type	Hydraulic two-circuit type
Mechanical	Mechanical

10 <sup>3</sup> / <sub>4</sub> " (273 mm)	10 <sup>3</sup> / <sub>4</sub> " (273 mm)
8" (203.2 mm)	8" (203.2 mm)
3/4"	3/4"
2"	2"
3/4"	3/4"
8" × 1 <sup>1</sup> / <sub>2</sub> "	8" × 1 <sup>1</sup> / <sub>2</sub> "
10 <sup>1</sup> / <sub>2</sub> "	10 <sup>1</sup> / <sub>2</sub> "
8 <sup>1</sup> / <sub>2</sub> "	8 <sup>1</sup> / <sub>2</sub> "
Hose	Hose
3/16" Bundy piping	3/16" Bundy piping
Lookheed Brake fluid 328 or equivalent according to min. requirement of SAE 70 R 3	

Clearance between master cylinder piston and pushrod	min. 0.8 mm (0.03 in.)
Same clearance measured at point of brake pedal	5—10 mm (0.2—0.4 in.)
The brake drum may be turned to a max.dia. of.....	204.7 mm (7.665 in.)
Radial throw, brake drum, total gauge reading .....	max. 0.15 mm (0.006 in.)
Axial throw, brake disc, total gauge reading .....	max. 0.2 mm (0.008 in.)

0.6—1.2 mm (0.02—0.05 in.)	3—6 mm (0.11—0.24 in.)
	204.7 mm (7.665 in.)
	max. 0.15 mm (0.006 in.)
	max. 0.2 mm (0.008 in.)

### TORQUES

Slotted nut, front hub .....	18 kpm (130 lb.ft.)
Slotted nut, rear hub .....	9.5 kmp (68.5 lb.ft.)
Bolts for brake housing .....	5.2 kpm (27.5 lb.ft.)



## 1. Technical data

### BATTERY

Voltage .....	12 V
Capacity .....	34 Ah

### DYNAMO, Bosch

Type .....	LJ/GEG 160/12/2500 + W30R4
Effect .....	240 W
Rated voltage .....	12 V
Rated speed .....	2,500 r.p.m.
Max. permissible load .....	20 A
Direction of rotation .....	Clockwise
Brush spring pressure .....	450—600 grammes (16—21 oz.)

### CHARGING RELAY, Bosch

Up to chassis NO. 168.000

Type designation .....	RS/TBA 160/12/1
Cut-in voltage .....	12.4—13.1 V
Control voltage when idling .....	14.5—15.5 V
Control voltage when under load 15 A .....	13.4—14.4 V
Reverse current relay breaks at .....	2.0— 7.5 A

From chassis No. 168.001

Type designation .....	RS/VA 200/12 A (2/1)
Cut-in voltage .....	12.4—13.1 V
Control voltage when idling .....	13.8—14.8 V
Control voltage when under load 25A .....	13.3—14.3 V
Reverse current relay breaks at .....	2.0—7.5 A

### STARTER MOTOR, Bosch

Type designation .....	AL/EDD 0.5/12R4
Number of teeth on pinion .....	9
Number of teeth on ring gear .....	97
Brush spring pressure .....	550—700 grammes (20—25 oz.)

### DISTRIBUTOR, Bosch

Type designation .....	VJ 3 BR9T
Capacitor .....	LMKO 1 Z30
Ignition settings:	
Basic setting .....	10° B.T.D.C.
At 3,000 r.p.m. ....	20° B.T.D.C.
Order of firing (1st cylinder at rear) .....	1—2—3
Breaker clearance .....	0.3—0.4 mm (0.012—0.016 in.)
Dwell angle .....	80—84°
Contact pressure .....	1,100—1,200 grammes (39—42 oz.)
Direction of rotation .....	Clockwise
Axial play, distributor shaft .....	0.1—0.2 mm (0.004—0.008 in.)

### IGNITION COIL

Type designation:

combined with ignition switch .....	Bosch ZS/KZW 1/12 (1/6)
without ignition switch .....	Mallory Scott E3LC-134 or Bosch TkW 12 (1/6)

Pre-connection resistance .....	Mallory Scott 201005
---------------------------------	----------------------

### SPARK PLUGS, Champion

Type .....	Surface gap
Designation .....	UK-16V
Spark plug gap, new plug .....	0.7 mm (0.03 in.)
Spark plug gap, max. ....	1.2 mm (0.05 in.)
Thread .....	18 mm
Tightening torque .....	2 kpm (14.4 lbs/ft.)



### IGNITION COIL

Type designation:

combined with ignition switch .....	Bosch ZS/KZW 1/12 (1/6)
without ignition switch .....	Mallory Scott E3LC-134 or Bosch TkW 12 (1/6)

Pre-connection resistance .....	Bosch TkW12 (1/6)
	Mallory Scott 201005

### SPARK PLUGS

Champion UK-16V Hard driving

Type .....	Surface gap
Spark plug gap, new plug .....	0.7 mm (0.03 in.)
Spark plug gap, max. ....	1.2 mm (0.05 in.)
Thread .....	18 mm
Tightening torque .....	2 kpm (14.4 lbs/ft.)

Champion UK-7 (UK-162) Normal driving

Type .....	side electrode
Spark plug gap .....	0.8 mm (0.032 in.)
Thread .....	18 mm
Tightening torque .....	4.5 kpm (32.4 lbs/ft.)

### BULBS

Number	Part Name	W	SAAB No.	Philips No.	
4	Bulb, fuel gauge, thermometer, speedometer .....	1.2 W	719018	Tungstam 2695	Chassis up to 201.400
10	Control- and instrumentlights .....	2 W	708434	12829	
2	Tachometer and clock .....	2 W	715489	12913	
2	Sealed Beam USA .....	50/40 W			
2	Headlights, asymmetric .....	45/40 W	710872	12620	
2	Turn indicators/parking lights, front .....	25/7 W or			
		32 Cp	709683	1034	
2	Tail light .....	5 W	715472	12821	
2	Turn indicators/stop lights, rear .....	25 W or			
		32/4 Cp	715471	1073	
2	Fog light and spot light .....	35 W	713342	12227	
1	Courtesy light .....	5 W	708419	12844	
2	Back-up lights .....	25 W	709683	1034	
2	Number-plate lights .....	5 W	708419	12844	
1	Luggage compartment lamp .....	4 W	715730	12929	

FUSES .....	16 pcs. 8 Amp
-------------	---------------

### FLASHER RELAY

Type designation:

Lucas .....	FL 5 12 V 42 W
Hella .....	91 Pst 2x32 Cp 12 V

### HORN

Type designation .....

B 31 — 12 V

### FUEL GAUGE TANK UNIT, VDO

Type designation .....

VDO 625

### WINDSHIELD WIPER MOTOR

Type designation:

SWF LHD car .....	SWA 1105/66 b
SWF RHD car .....	SWA 1105/66 r

### HEATER FAN MOTOR

Type designation

Electrolux .....

KS 3442/240

### WINDSHIELD WASHER MOTOR, Bosch

Type designation .....

WS/SPE 2/12/1





## Description

### GENERAL

The Saab "Granturismo 850" (Saab 96 Sport) has a three cylinder water-cooled two-stroke engine incorporating Schnürle-type crankcase scavenging, piston-regulated port timing, and cylinder scavenging. The engine has a separate lubrication system, the oil from an oil tank being pumped direct to the cylinders and bearings.

The piston displacement is 841 cc (51,3 cu.in.) which is the same as for the Saab 95 och 96. Stroke and bore are also the same as in these models.

The cylinder block and crankcase are cylinder castings; steel pipes cast in the cylinder block feed oil to the three cylinders and four main bearings.

The cylinder head is manufactured of a light metal alloy. The crankshaft is built as a composite unit of considerable strength; it is made up of six crank discs and seven crank pins held together by force fit. This has made it possible to use single ball bearings and double roller bearings for the main bearings and big ends respectively. There are four main bearings. The crank discs are round in order to obtain a higher crankcase compression than

in the Saab 95 and 96. The three crankcase partitions are sealed from one another and from either end by piston-ring type seals, each of which consists of two rings fitted into guides. The rings do not rotate but function in principle as a labyrinth seal.

The connecting rods are drop-forged and hardened. Their machined surfaces function as races for the big and small end bearings. The big end bearing consists of a double row of rollers contained in a cage. The small end has a needle bearing. Axial movement of the connecting rods is controlled from the small end, there being considerable play between the crank discs at the big end.

It is most important that the crankshaft is assembled correctly. For this reason it should only be overhauled by the manufacturer. Only the complete assembly is to be had as a spare.

The all-metal pistons have very thick heads and are fitted with two compression rings and one scraper ring.

There are three Solex 34 BIC down draft carburetors connected by an equalizing pipe cast in the inlet manifold.



Oil tank and oil pump

S 104

The moving parts of the engine are lubricated with oil from a separate tank, placed to the left of the engine. This tank holds about 3 liters (0,8 US gallons), sufficient for 1500—2000 kilometers (900—1200 miles). A glass gauge on the outside of the tank shows the oil level and a warning lamp on the instrument panel lights up if the supply of oil should fail for any reason. An oil pump, driven of the engine crankshaft, pumps the oil via separate ducts in the engine housing to each of the cylinders and main bearings. From the main bearings the oil is forced on to the big end bearings and also splash lubricates

the cylinder walls. The drive to the oil pump also turns the distributor, its revolutions being reduced by an epicyclic gear in the pump itself. The cylinder and the piston rotate slowly at the same time as the piston expels the oil. During this rotation each oil duct is exposed in turn. The oil pump piston is steered by a cam.

The power increase compared to the Saab 95 and 96 has been obtained by changing the port times, increasing the compression ratios in the crankcase and the compression chambers, and by fitting three carburetors and altering the exhaust system.



## Lifting out and installing

### LIFTING OUT THE POWER UNIT

1. Release the ground strap at the power unit and battery.
2. Disconnect the hood by
  - a. Disconnecting the lighting cables, horn cables, shutter chain and stop band.
  - b. Moving the hood backwards and upwards until it slides off the hinge pins.
3. Drain off the coolant.
4. Disconnect the dynamo cables, the high-tension cable, the distributor cap and the ignition cables.
5. Remove the intake silencer with filter and pre-heating unit.
6. Release the fuel hose at the fuel pump and the starter linkage at the carburetor. The rubber boot for the throttle linkage is disconnected from the plate on the throttle spindle.
7. Disconnect the oil pressure sender cable at the oil pump.
8. Disconnect the oil hose at the oil pump connection. Bend up the hose and fasten it in this position so that the oil cannot run out. Cover the connections so that dirt and dust cannot enter the pump or hose.
9. Disconnect and remove the two starter motor fixing screws and place the starter motor on the floor plating. N.B. It is not necessary to disconnect the starter motor cables.
10. Loosen the muffler suspension nuts. See illustration.
11. Loosen the connection between the muffler and the exhaust manifold.
12. Release the clamping to the exhaust pipe and lower the muffler.
13. Loosen the two forward engine anchorages at the body. The six screws are accessible under the floor of the engine housing.
14. Disconnect the clutch cable at the power unit by releasing the tension of the cable and unhooking it at the anchorage under the engine.
15. Loosen the side stays.
16. Unscrew the temperature gauge sender.
17. Disconnect the upper radiator hose at the thermostat.
18. Disconnect the lower hose at the pump.
19. Fit lifting hook 784059. Lift out the engine and block up the gearbox with a 90 mm (3.5 in.) high wooden block or something similar.
20. Separate the engine from the gearbox, and then lift out of the car. Take care that the clutch shaft does not break so that the sealing is damaged.

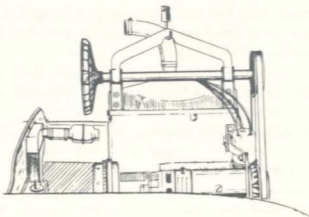

S 105

Lifting out the engine. Note the block under the gearbox.

### INSTALLING THE POWER UNIT

1. Lift the engine into the car. Use lifting hook 784059, see illustration. Make sure that the clutch shaft splines are undamaged and, if necessary, lubricate them with a little graphite grease. Put a little grease (Bosch Ft 1 V13) on the starter gear.
2. Bolt the engine and gearbox together and connect the engine ground strap. Do not forget the anchorage for the clutch cable.
3. Fit the clutch cable.
4. Fit the starter motor.
5. Remove the block under the gearbox and lower the unit.
6. Fasten the forward engine anchorages to the body.
7. Connect the engine side stays, so that the engine sits evenly and is not pulled in any one direction.
8. Fit the muffler by fixing it at the exhaust manifold and muffler anchorage. NB. Do not tighten it finally.
9. Connect the muffler to the exhaust manifold, after which the suspension nut and the clamp for the exhaust pipe are tightened.
10. Fit the temperature gauge sender.
11. Connect the electrical cables to the dynamo and distributor cap and ignition cables.
12. Fit the throttle and start linkages.
13. Connect the radiator hoses.
14. Connect the hose to the fuel pump.
15. Connect the hose to the oil pump, and the electrical cable to the sender.
16. Remove the metal, or plastic, plug which is in the middle of the upper section of the pump, see illustration.
17. Using tool 784128, or a screw driver, turn the pump shaft 100 times. The shaft can only be turned clockwise.

#### NOTE

When the oil pump, or the engine, has been removed the pump shaft must always be turned about 100 times after the hose from the tank has been connected. This is to fill the pump and lubricating channels with oil.

#### WARNING

If the pump shaft is allowed to rotate faster than about 60 r.p.m. the pump will be damaged. Electric drills, etc. may absolutely not be used for this purpose.

# 3 POWER UNIT



18. Refit the plug over the pump shaft.
19. Fit the intake silencer with air filter and preheating unit.
20. Put on the hood. Connect the electrical cables, shutter chain and stop band.
21. Fill with coolant.
22. Connect the battery ground strap.
23. Adjust the play of the clutch pedal.
24. Adjust the ignition setting as instructed in Chapter 15.
25. Test the engine.
26. After the engine has cooled retighten the cylinder head if this has been removed.

## DISASSEMBLING

1. Clean the outside of the engine.
2. Remove the V-belt, dynamo and water pump.
3. Remove the intake manifold together with the carburetors.
4. Remove the exhaust manifold.
5. Remove the cylinder head bolts and remove the cylinder head and fan bearing bracket.
6. Loosen the clamp screw and take out the distributor.
7. Turn over the engine so that it stands on the cylinder head contact surface. Make sure that the surface it is standing on is clean and does not scratch the sealing surface.
8. Loosen the oil pump fixing screws and remove the pump.
9. Loosen the nut for the crankshaft pulley and remove the vibration damper and pulley. Use puller 784055.
10. Remove the clutch unit. Push in spacer washers 784065 under the clutch levers and loosen the clutch fixing screws. Remove the clutch.
11. Bend up the lock washer and loosen the flywheel anchorage bolts. Remove the flywheel.
12. Remove the engine anchorages under the crankcase half and the lower water pipe from the engine block.
13. Loosen the screws and lift off the lower crankcase half.
14. Take off the distributor gear housing outer cover with seal, O-ring, lock ring and spacers.
15. Remove the distributor gear and fibre washer.
16. Remove, and take care of, the two pins and springs for the dog clutch.
17. Lift out the crankshaft with pistons. Take care that the connecting rods not bent nor the pistons damaged. To facilitate lifting out put clutch centring drift 784064 in the crankshaft bushing and screw tool 784057 on the journal on the other end of the crankshaft, see illustration.
18. Remove the circlips in the pistons and drive out the piston pins with tool 784061. Take care and hold the tool steady so that the connecting rods are not bent nor the pistons damaged.

## ASSEMBLY

Inspect and clean all engine parts and replace damaged parts and all gaskets. The cylinder head gasket may not, under any circumstances whatsoever, be refitted. Regarding tightening torques see the table in section 1. Regarding the inspection and overhaul of the engine parts we refer you to the relevant sections, where the working operations are described.

1. Measure the cylinders and pistons to ascertain that the prescribed play is retained. Subsequent classification of new pistons,

2. Inspect the needle bearing classifications or classify new needle bearings if the crankshafts or pistons have been replaced.
3. Fit the piston rings with the aid of a piston ring plier.

### NOTE

The lower piston ring is an oil scraper ring, and is thinner than the others.

4. Fit the pistons to the connecting rods. Tool 784061 is used for this purpose. The guide pin is fitted first to guide the needle bearing. Fit the piston pins and the circlips.

### NOTE

The pistons are fitted with the arrow facing forward (towards the ignition end).

5. Make sure that the crankshaft seal ring is fitted in the ignition end. If it has been removed make sure, when fitting, that the "piston rings" are situated with their gaps 180° from each other.
6. Fit the woodruff key in the ignition end of the crankshaft.
7. Fit tool 784057 in the forward end of the crankshaft and push centring drift in the crankshaft bushing. Place the piston ring gap immediately opposite the lock pin on the pistons and put the crankshaft and pistons into the engine block. The centre piston is lowered in first, see the illustration. Oil in the pistons and cylinders before assembly and take care that the piston rings are not damaged.
8. Take off the two tools and fit the two springs and pins for the dog clutch in the ignition end of the crankshaft.
9. Fit the distributor gear, so that the pointed pin is in the gear recess. Oil the parts before assembly.
10. Fit the fibre washer for the distributor gear.
11. Fit the lower crankcase half and tighten the screws successively with the following torques:  $\frac{5}{16}$ " screws with 2.5 kpm (17 lbs./ft.) and  $\frac{3}{8}$ " screws with 4 kpm (29 lbs./ft.).

### NOTE

No sealing agent or gasket may be used in the sealing surfaces between the engine block and the crankcase half. Check that the surfaces are clean and undamaged, and oil with engine oil.

12. Check that the distributor gear is placed correctly, with the pointed pin in the groove, and that the fibre washer is in its place.
13. Fit the outer cover with O-ring and shaft seal. Fit tools 784057 and 784127 on the crankshaft journal and push in the cover by screwing in the tools.
14. Place in the filler washers, in front of the cover, and fit the lock ring. Make sure that the lock ring is completely pressed in the groove.
15. Release the tools between a quarter and half a turn and check that the spacer washers suffice. If this is not the case remove the lock ring and fit in more spacers.





16. Remove the tools when the fitting is satisfactory.
17. Fit the pulley and vibration damper.  
Do not forget the tab washer under the nut. Tighten the nut to 5 kpm (36 lbs./ft.).
18. Fit the flywheel with a new lock washer, tighten the screws with a hex. box spanner to a torque of 3 kpm (22 lbs./ft.). Lock the screws.

**NOTE**

Special screws are used for the flywheel.

19. Fit in the clutch disc and fit the clutch. Make sure that the three spacer washers are situated correctly. Centre the clutch disc with drift 784064, while the screws are tightened successively and then remove the spacer washers and drift.

**IMPORTANT**

There are certain colour markings on the flywheel and clutches for the balancing of the clutch. These shall be turned 180° from each other.

20. Fit the oil pump and gasket.
21. Fit the engine anchorage and lower water pipe. The gasket shall be coated on both sides with sealing agent.
22. Turn over the block and clean the cylinder head and block sealing surfaces.

**IMPORTANT**

A special cylinder head gasket, "Reinz Super", is used. This **must not** be coated with sealing agent, Permatex or the like.

23. Fit the cylinder head gasket with the wide bevelled pad towards the cylinder head.
24. Fit the cylinder head, with the already attached fan bearing bracket, and tighten the bolts successively. Regarding the tightening sequence and torques see section 5.
25. Fit the intake manifold and carburetors.
26. Pour 50 cm<sup>3</sup> (3 cu.in.) engine oil into the distributor gear housing, through the hole in the distributor.

**NOTE**

50 cm<sup>3</sup> (3 cu.in.) engine oil must always be poured into the distributor gear housing when the engine has been disassembled. This level is then held constant by direct lubrication from the oil pump when the engine is running.

**IMPORTANT**

The cylinder head gasket **must not** be coated with sealing agent.

Tightening torque: 5 kpm (36 lbs./ft.).

The first retightening shall be carried out immediately the engine has cooled after testing.

27. Fit the distributor. See Chapter 15.
28. Fit the dynamo and connect the lower radiator hose to the pump.
29. Put on the belt and adjust the belt tension.
30. Fit the exhaust manifold and gaskets.

## Cylinder head

### GENERAL

When the cylinder head is to be removed the engine must be allowed to cool before removal commences. Otherwise there is a risk that the cylinder head will become warped. The flatness of the cylinder head shall be adjusted. This is most suitable done on a plane disc with a fine polisher. This type of levelling is usually sufficient and machining should be avoided. If the faults are great the cylinder head should be replaced.

The spark plug threads shall be cleaned out with a thread pin. Carbon deposits in the lower threads can give rise to damaged threads when the plugs are changed. If these are damaged, however, there is the possibility of fitting Helicoil inserts. This also applies to the temperature gauge sender connection and the anchorage bolts for the fan bearing bracket.

### REMOVING AND FITTING

When only the cylinder head is to be removed the procedure is as follows:

1. Drain off the coolant and allow the engine to cool down (below 30° C).
2. Remove the air filter and preheating unit.
3. Loosen the dynamo adjuster and fixing screws and lift off the fan belt.
4. Disconnect the radiator hose from the cylinder head.
5. Disconnect the cables from the spark plugs.
6. Unscrew the temperature gauge sender.
7. Loosen the cylinder head bolts successively and remove the bolts. Bend over the anchorage for the engine side support.
8. Remove the cylinder head and gasket.
9. Dry off any water drops in the cylinder bore and cover the cylinders with a clean cloth.
10. If necessary remove the spark plugs and fan bearing bracket.

Fitting is carried out in the opposite order, and the following shall be especially noted:

The sealing surfaces of the cylinder head and cylinder block shall be cleaned carefully before fitting and the levelling shall be inspected.

If coolant has got into the crankcase, turn the engine over, first manually and then with the starter motor whilst com-

The second retightening shall be carried out after 1,000—1,500 km (600—900 miles).

The third retightening shall be carried out after 2,500—3,000 km (1,500—1,800 miles).

All retightening shall be carried out with a cold engine (below 30° C).



# 3 POWER UNIT



pressed air and thin oil are sprayed through the carburetors. Any coolant will then come up through the overflow channels and the engine parts are simultaneously oiled in. The cylinder head gasket to be used is a special black gasket. Pads are only around the cylinders and the gasket material is reinforced with metal mesh. This gasket **may not** be coated with sealing agent, oil Permatex or the like.

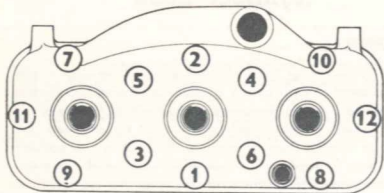

Tightening sequence for cylinder head bolts

The gasket shall be turned with the wide bevelled pads towards the cylinder head.

See to it that gasket and contact surfaces as well are dry when being fitted.

Center gasket and cylinder head carefully against the engine block.

Before fitting the cylinder head bolts the threads are cleaned with a wire brush and sparingly lubricated with oil or graphite grease. Tightening is then carried out successively, to a torque of 5 kpm, (36 lbs./ft.) in the sequence shown in the illustration. After warming up the engine should be allowed to cool (to about 30° C) before the bolts are retightened. Retightening should be carried out in the same sequence as tightening. Loosen each bolt slightly before retightening to ascertain that the bolt has not stuck in the thread.

## Engine block

### GENERAL

The engine block and crankcase are matched as a pair which means that it is not possible to replace the block or the crankcase separately. A crankcase number is stamped on both sides of the separating level at the rear of the right-hand side of the engine.

As well as the engine number, which is stamped immediately under the cylinder head on the right-hand side of the engine, the left-hand side is stamped with the classification the respective cylinders have. See the illustration.

If the cylinder bore is damaged owing to piston seizure, piston ring breakage or excessive wear, the bore must be machined. A cylinder gauge is used to measure the bore. The cylinder bore is normally more worn in the upper section and is therefore tapered and out-of-round. To obtain a comprehensive picture of the cylinder it should be measured in several positions in both the longitudinal and transverse directions of the engine. The degree of wear is obtained by comparing the largest and smallest values.

### HONING

When replacing pistons, owing to excess noise (excess piston clearance), it is often necessary to hone the cylinder bore. This is partly to remove any unevenness or scratches and partly to suit the clearance to the class of piston to be used. If, on the other hand, the pistons are to be replaced after a relatively short time it is not necessary to hone the bore. In the case of long periods of operation the turning edge must always be removed.

### BORING

If the cylinder is to be bored, choose a suitable oversize depended on the extent of the damage. Regarding cylinder classifications see sections 1

After boring the parts must always be bevelled according to the illustration, otherwise there will be a risk of piston ring breakage. Beveling, which shall be greatest in the centre of the port and diminish towards the sides shall be carried out with a rotating file.

#### NOTE

When machining a cylinder bore it is imperative that all grindings and the like are removed. This is best done by cleaning the block and crankcase in a degreasing tank.

### FITTING THE CRANKCASE

When fitting and removing, the description in section 4 shall be adhered to. As well as this the following should be noted.

When fitting the crankcase to the block the contact surface shall be clean. Gaskets nor any form of sealing may be used whatsoever. The sealing surfaces may only be oiled in. Note that there are two types of bolts and that the tightening torques are different. NB. Do not forget to fit and tighten the bolts at the rear, which are situated on the flywheel side of the block.

### INSPECTING THE OIL CHANNELS

Seven steel pipes are cast into the block. These lead the oil from the oil pump out to the main bearings and cylinders.

If it is suspected that there are impurities in the oil channels this can be checked by pushing a 1 mm nylon line (fishing line) through the oil channels. If a channel should be blocked it can be cleaned out with a 0.5 mm piano wire. The oil channels should be specially inspected after the cylinder block has been bored.

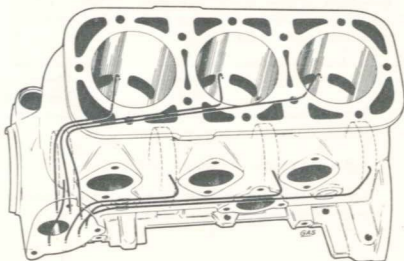



## Pistons and piston pin bearings

### PISTONS

#### GENERAL

Pistons for the Saab "Granturismo 850" (Saab 96 Sport) are of the all-metal type, and are equipped with a very thick piston bottom.

The three piston rings are hard-chromed steel rings, the lowest of which is smaller than the other two and serves as an oil scraper ring. This ring is bevelled at the top and has a sharp edge at the bottom.

Standard classes for cylinders and pistons	Oversizes and classes for cylinders and pistons
A	ØD 0.5 A
AB	ØD 0.5 B
B	ØD 1.0 A
C	ØD 1.0 B

When fitting pistons the same class shall be used for both pistons and cylinders. The cylinder class is stamped on the exhaust side of the cylinder block and the piston class is stamped on the top of the piston. An engine block can have differing classes on the three cylinders.

When a piston is measured it must be at right-angles with the piston pin and 15 mm from the lower edge of the piston. This is where the piston is largest and it is this value which is given in Technical Data, section 1. The piston is oval ground and tapers both upwards and downwards from this point.

#### REMOVING AND FITTING

When removing and fitting the description in section 4 must be observed. There are different colour markings in the piston and piston pin respectively, which show the fitting of the pin in the piston. See the illustration. A piston assembly consists of piston, piston pin and piston rings. For example, when replacing pistons make sure that the piston pins are not mixed up but that the pin mated to the piston is fitted. The piston pin is fitted with "light thumb pressure" into the piston.

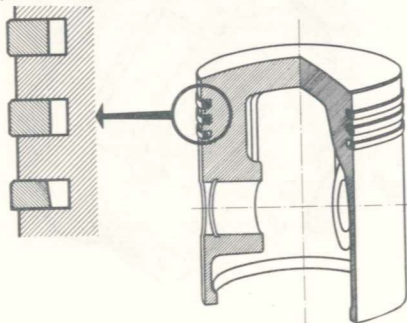

Piston with piston rings

The following colour markings can appear:

Red marked piston is fitted with red marked pin. Blue marked piston fitted with blue marked pin. Red marked parts have the largest diameter.

When fitting piston, piston pin and needle bearing to the connecting rod use guide drift 784061. See the illustration. When fitting the piston pin hold the piston firmly in your hand so that the connecting rod is not bent. When fitting the piston make sure that the piston is turned the right way. The reason for this is that the lock pin for the upper piston ring must not be fitted in the vicinity of the warm exhaust port.

#### NOTE

Fit the piston with the marking F forward, towards the ignition end. Do not forget to fit the circlips.

### PISTON PIN BEARINGS

To meet the demands of precise piston pin bearing fitting there is a series of nine bearings. The tolerances and markings of these bearings are shown in the table below. The table also shows the differentiations from the basic diameter, which is 2.000 mm. The bearings marked + are a form of oversize and are normally used on spare parts shafts.

NB. If a bearing has no prefix to its serial number it is a — bearing. See illustration.

Needle group	Marking
+0.008 — +0.006	+7
+0.006 — +0.004	+5
+0.004 — +0.002	+3
+0.002 — 0	+1
+ 0 — -0.002	-1
-0.002 — -0.004	-3
-0.004 — -0.006	-5
-0.006 — -0.008	-7
-0.008 — -0.01	-9

When overhauling a piston pin bearing both the piston pin and needle bearing should be replaced.

Before fitting a piston the piston pin must be paired with the needle bearing to the correct fitting in the connecting rod. The bearing shall be as nearly as possible free of play, without the piston pin being forced in, when it is fitted in the connecting rod. See the illustration.

#### WARNING

Light thumb pressure is the maximum permissible fitting of the needle bearing.

#### NOTE

New needle bearings must be classified when pistons or crankshaft are replaced.

# 3 POWER UNIT



## Crankshaft

### GENERAL

The crankshaft is a composite unit, which means that it is impossible to replace its component parts.

The crankshaft is lubricated by the oil being led through oil channels in the block to the groove for the main bearing sealing rings. From there the oil is led through the main bearings, caught up by an oil catcher and led out to the crank pin and big end bearings, see the illustration. The connecting rods are guided axially up in the pistons, which gives a large clearance between the webs.

On a crankshaft, which is not installed, the main bearings have greater play than normal ball bearings. When installed the play is reduced somewhat as the bearing caps are compressed by the engine block and the crankcase half.

The main and big-end bearings are very susceptible to foreign particles and the crankshaft must thus be well protected when not installed.

#### NOTE

Always take care, when handling the crankshaft, that the connecting rods are not bent nor the alignment risked.

### REPLACEMENT OF THE CLUTCH SHAFT BUSHING

If, after cleaning, the bushing shows signs of damage, or has excessive play, it must be replaced. As this play has a great influence on the length of life of the clutch shaft seal, only a play of up to 0.04 mm is permissible. When removing the old bushing it is suitable to use a 16 mm threaded drift and a steel ball. When the threaded drift bottoms against the steel ball the bushing comes out with repeated turning.

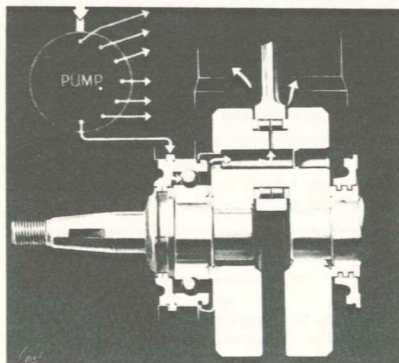

Crankshaft lubrication system

## Flywheel

### REPLACING THE STARTER GEAR

If the starter gear is to be replaced the engine is lifted out of the car and the flywheel screwed off. Note that when the flywheel screws have been removed the rear main bearing is exposed through the screw holes. Care must be taken so that no foreign particles get into the bearing. The old starter gear is removed by drilling a 5 mm hole through it from the back and then splitting it with a chisel.

When installing a new starter gear it must be heated to about 200° C. This temperature must be evenly distributed over the whole of the gear and not just in parts.

After heating lay the starter gear on the flywheel with the bevels on the teeth facing upwards. Make sure that the gear lies against the rim all the way round. Avoid hitting the heated gear with a hammer.

### GRINDING AND TURNING THE FLYWHEEL

This operation can be necessary if the contact surface for the clutch is worn or scratched. Turning down to 0.5 mm is permissible. In the case of deeper scratches the flywheel should be replaced.

#### NOTE

In the case of all machining on the flywheel, in principle an equivalent turning of the clutch plate contact surface must be carried out so not to disturb the relationship between the clutch and the flywheel.

### INSTALLING THE FLYWHEEL

It must be noted that the flywheel screws are of a special material and may not be replaced by standard screws.

New lock washers must always be used when installing the flywheel. Do not forget that the bolts must be tightened with a torque spanner [3 kpm (22 lbs/ft.)].

After installation coat the starter gear teeth with grease — Bosch Fl 1 v 13.

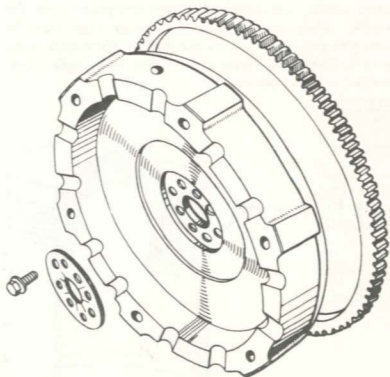

Flywheel and starter gear





## Pump and distributor drive with vibration damper

### GENERAL

The distributor gear housing is composed of an extension of the crankcase at the forward end of the engine. It is a completely enclosed area, limited by the crankshaft piston ring seal at the crankcase and a seal ring forward at the pulley. See the illustration.

The distributor drive also drives the oil pump and is equipped with a clutch which comes into operation if the pump should seize or if the oil is too thick.

The clutch consists of two pins, which lie against the inner side of the gear. One of the pins, the lock pin, is pointed and fits in a recess on the gear and locks the gear in relation to the crankshaft. On the outer side of the gear, between the gear and the pulley hub, there is a friction washer against which the gear is pressed by the spring loading of the pins.

If the pump seizes the lock pin cannot retain the gear and remains stationary (slips) in relation to the crankshaft, whereupon the engine cannot be started. If the pump seizes when driving the engine stalls owing to the fact that the ignition setting becomes faulty.

When the fault has been repaired, turn the crankshaft over manually whilst braking the distributor rotor. The gear re-attains the correct position owing to the fact that there is only one recess for the lock pin.

The distributor is lubricated with oil. When the engine has been disassembled 50 cm<sup>3</sup> (3 cu.in.) oil must always be poured into the distributor gear housing so that the correct oil level is attained. The bottom end of the distributor gear should be submerged in oil. When running only a small quantity of oil is allowed to enter, to compensate leakage. The oil is carried through the oil pump shaft bearing.

The pulley is fitted on the tapered pin on the crankshaft and is driven by a woodruff key. There is a rubber disc on the pulley and the vibration damper is pressed against this by a powerful coil spring. The vibration damper can thus move in the rubber and counteract the torsion vibrations of the crankshaft.

The pulley seal ring is fitted in a cap, which also has a seal against the engine block. This is composed of an O-ring. The cap is retained by a lock ring and shims. There are two thicknesses of shims — 0.3 and 0.5 mm. It is imperative that the lock ring lies correctly in its groove and that the right number and sizes of shims are inserted. Too many shims mean that the lock ring can loosen with resultant noise and oil leakage. Insufficient shims can cause oil leakage.

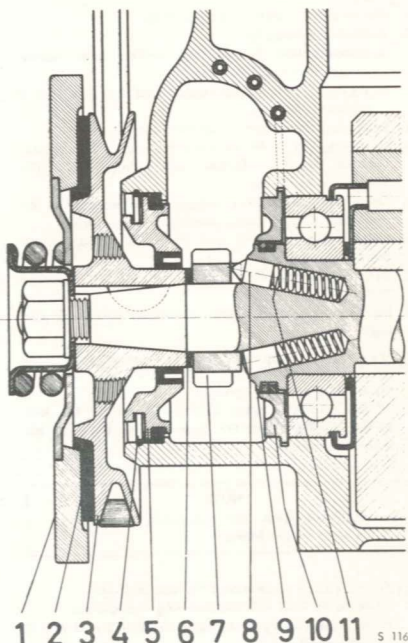

Pump and distributor drive with vibration damper

1. Vibration damper
2. Rubber ring
3. Pulley
4. Lock ring and shims
5. Outer cap and seals
6. Friction washer
7. Distributor gear
8. Lock pin
9. Piston ring seal
10. Inner cap
11. Spring



# 3 POWER UNIT



## Oil pump

### REMOVING THE DISTRIBUTOR GEAR

1. Disconnect the battery ground strap.
2. Remove the hood by:
  - a. disconnecting the lighting cables, horn cables, shutter chain and stop band.
  - b. moving the hood backwards and upwards until it glides off the hinge pins.
3. Loosening the dynamo and removing the belt.
4. Loosening the nut for the crankshaft pulley and removing the vibration damper and pulley. Use puller 784055 for the pulley.
5. Loosen the distributor clamping screw and pull up the distributor. The oil pump need not be removed.
6. Remove the lock ring and shims for the distributor gear housing cap.
7. Remove the cap, if necessary with the aid of puller 784054.
8. Remove the friction washer, distributor gear, lock pins and springs.

### INSTALLING THE DISTRIBUTOR GEAR

1. Fit the lock pins and springs.
2. Fit the distributor gear with the recess for the lock turned inwards. Turn the gear so that the lock pin enters the recess.

#### NOTE

The distributor gear must turn easily on the shaft. Oil the gear before fitting.

3. Fit the friction washer and the woodruff key.
4. Fit the outer cap with the seal ring and O-ring.
5. Push in the cap by screwing tools 784050 and 784127 onto the shaft pin.
6. Place a suitable number of shims between the lock ring groove and cap.
7. Fit the lock ring. Make sure that it goes into the groove.
8. Release the tool between a quarter and half a turn and make sure that the shims lie properly against the lock ring. Otherwise the lock ring must be removed and the combination of shims altered.
9. Remove the tool from the shaft.
10. Press on the pulley.
11. Fit the vibration damper. Do not forget the lock washer under the nut. Tightening torque: 5 kpm (36 lbs./ft.).
12. Pour 50 cm<sup>3</sup> (3 cu.in.) oil into the distributor housing.

#### NOTE

When the distributor gear housing has been disassembled 50 cm<sup>3</sup> (3 cu.in.) of engine oil must always be poured in before the distributor is fitted.

13. Fit the distributor. See Chapter 15 regarding the ignition settings.
14. Fit the drive belt and tension the dynamo.
15. Fit on the hood and stop band. Connect the lighting cables, horn cables and shutter chain.
16. Connect the battery ground strap.
17. Make sure that the lights and horn function properly.
18. Test.

### GENERAL

The oil pump is driven by the distributor gear on the crankshaft. The speed is substantially reduced by a planetary gear situated in the pump housing. When the pump is operating the pump cylinder and plunger rotate slowly at the same time as the plunger reciprocates in the cylinder. The plunger obtains its movement from a tappet. As the cylinder rotates the oil channels are exposed in turn thus feeding the seven lubricating points.

The oil channels in the engine block and pump meet at the contact surface between the block and pump and sealing is accomplished with a gasket.

Over and above the seven points in the engine block the distributor gear is also lubricated, by the oil which has first lubricated the planetary gear and the pump shaft.

To indicate the oil pressure there is a sender in the pump. This sender, which is mainly composed of a spring-loaded piston influenced by the oil pressure, is connected to a warning lamp on the dashboard through the medium of cables and a relay. When the engine is still or if the oil pressure falls below a certain minimum value the line from the pump to the relay is grounded continually and the warning lamp lights up. The lamp never lights up when oil pressure is normal.

There are two makes of oil pump but their operation is principally equal. The oil pumps are sealed and the seals may not be broken. If a pump is damaged it must be completely replaced. There is an exchange system for this component, provided that the seal is unbroken. The only permissible repair operations in conjunction with the pump is the replacement of the contact unit for the oil pressure sender and the replacement of the pump gear.

### REPLACING THE OIL PUMP OR PUMP GEAR

#### REMOVAL

1. Disconnect the battery ground strap.
2. Remove the hood by:
  - a. disconnecting the lighting cables, horn cables and shutter chain and stop band.
  - b. moving the hood backwards and upwards until it glides off the hinge pins.
3. Disconnect the nipple for the oil hose at the pump and fasten up the hose at the oil reservoir so that the oil does not run out of the reservoir. Cover the connections so that no dirt can get in.
4. Disconnect the cable connection at the sender.
5. Unscrew the three pump fixing screws.
6. Pull out the pump.
7. If the pump drive shaft be replaced:
 

File off and drive out the pin for the pump gear, take care that neither the pump nor the pump shaft are damaged. Protect the oil channels on the flange from dirt and filings.
8. Pull off the gear.



- SAAB oil pump
1. Plug for pump shaft
  2. Oil pressure sender

**FITTING**

1. Fit the gear onto the shaft. Adjust the axial play to 0.1—0.2 mm before finally driving in the pin. When riveting the pin care must be taken not to damage the shaft or the pump. The rivet head may not exceed a height of 0.5 mm.
2. Fit the pump and screw it onto the block, use a new flange gasket.
3. Connect the oil hose and the cable to the sender.
4. Remove the metal or plastic plug in the centre of the upper section of the oil pump. See the illustration.
5. Rotate the pump shaft 100 times with the aid of tool 78412B or a screwdriver. The shaft can only be turned one way as it is locked in the other.

**NOTE**

When the oil pump or engine has been removed the oil pump shaft must always be turned over 100 times after the hose from the oil reservoir has been connected.

**WARNING**

If the pump shaft is allowed to rotate faster than 60 r.p.m. the pump will be damaged. Electric drills, etc., may absolutely not be used for this purpose.

6. Refit the plug over the pump shaft.
7. Fit the hood and stop band and reconnect the lighting cables, horn cables and shutter chain.
8. Connect the battery ground strap.
9. Make sure that the lights and horn function properly.
10. Test.

**NOTE**

If the engine has been removed and during removal the oil pump has come into a position where the oil has run out of the distributor gear housing, 50 cm<sup>3</sup> (3 cu.in.) new oil must be poured in before the pump or distributor are fitted.

**OIL PRESSURE SENDER****GENERAL**

The pump oil pressure sender shall ignite a warning lamp on the dashboard if the oil pressure is insufficient or zero. The impulse goes to the warning lamp via a relay. Wiring diagram, see Chapter 15.



Filling the oil channels by turning the pump shaft.

**DISASSEMBLING AND ASSEMBLING THE OIL PRESSURE SENDER**

1. Pull off the cable to the sender and unscrew the upper section of the contact unit. Look after the gasket.
2. Remove the spring, contact sleeve and piston, see the illustration. Pull out the piston carefully with a plier.
3. When fitting make sure that the piston slides easily in the cylinder.

**NOTE**

The fitting of the plunger in the cylinder is very precise. For this reason great care must be taken so that no dirt gets in when removing and fitting. The piston and cylinder are matched. This means that the piston cannot be replaced as a single unit.

**INSPECTING THE OIL PRESSURE SENDER.**

If the warning lamp on the dashboard ignites or if the lamp does not go out within 1½ minutes of starting the car, stop the engine immediately and investigate the following.

1. Make sure that there is oil in the reservoir.
2. See that the cable between the relay and the sender is not broken or that it is not short-circuited and in contact with the casting.
3. Inspect the sender as follows:
  - a. Disconnect the cable to the sender.
  - b. Connect a testing lamp between the positive terminal on the battery and the sender.
  - c. Remove the metal or plastic plug on the centre of the upper section of the pump.
  - d. Rotate the pump shaft with a screw driver or tool 78412B. If the lamp **flashes in synchronization** with the revolutions the sender is functioning and oil is being fed. The fault probably lies in the relay.
  - e. If the testing lamp **does not flash** but stays alight continually, or does not light up at all, the sender must be removed and examined. It is possible that the piston sticks in the cylinder or that the contact sleeve has stuck.

**CHECKING THE OIL FEED**

1. Check the oil level in the reservoir.
2. Then check the oil feed by seeing whether the oil comes through the holes at the anchorage flange. The pump shaft shall be rotated through the hole in the upper section of the pump. If the pump gear is rotated instead the oil will take much longer to come out owing to the greater ratio. If the oil feed is not functioning despite that the shaft is turned the pump must be replaced.

**INSPECTING THE PUMP GEAR**

If the oil pump seizes or if a thick oil is used in intense cold the distributor gear slips on the crankshaft. The ignition timing then becomes faulty and the engines stops.

If the fault is that the oil is too thick take the car into a warm garage and change the oil to that of the correct viscosity. When the oil pump has attained room temperature the distributor gear should retain the correct position when starting. If it does not do this remove the distributor cap and turn the crankshaft over manually whilst braking the distributor rotor lightly by hand. The clutch lock pin then attains the correct position in the recess in the gear. With continued rotation of the crankshaft (clockwise seen from the front) the distributor rotor should also rotate. If the distributor arm remains stationary the pump has probably seized. This is investigated by removing the pump and seeing whether the pump shaft turns easily.



## CARBURETORS

Three Solex 34 BIC down-draft carburetors are fitted to a common inlet manifold, which has a channel to each cylinder. There is a thin union channel cast into the manifold between these channels. This channel has the task of balancing the carburetors.

On the inlet manifold there is a volume screw for the air to the idling system. Air comes from the air cleaner through a hose to the inlet manifold, where the volume of air can be regulated by the volume screw. The air is then distributed into special channels up to each of the carburetor idling systems. On the carburetors are also volume screws,

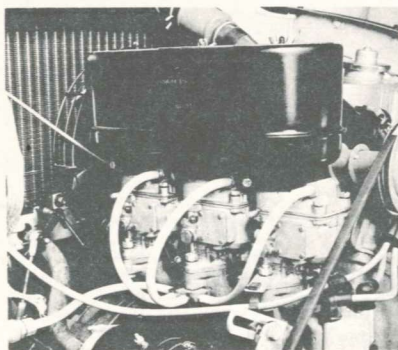

Carburetors and air filter

S 125

for the fuel-air mixture. These screws are locked with stop nuts and may not be altered, as they have been set at the factory with the aid of a flow gauge.

The center carburetor is furnished with a cold start unit, a bistarter; the other two carburetors have no such unit. The fuel-air mixture is distributed to the other cylinders through the balancing channel in the inlet manifold.

The carburetors have an air filter with three replaceable paper inserts. A detachable preheater tube is fitted between the air cleaner and the exhaust manifold.

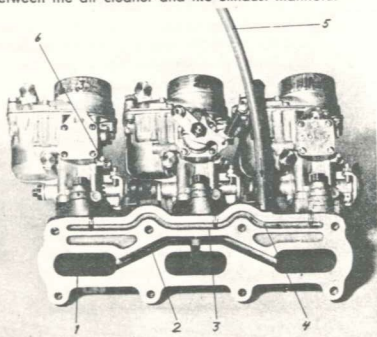

## Carburetors and inlet manifold

S 126

1. Channel to cylinder
2. Balancing channel
3. Distribution channel for air to idling system
4. Volume screw for air
5. Air hose to volume screw
6. Volume screw for fuel-air mixture

Note. Must not be moved

## GENERAL, SU FUEL PUMP

The SU fuel pump is an electric double-action pump. It has two independent pump units fitted in a common valve housing. The parts included in the pump unit, such as the solenoid housing, diaphragm, pump spring

breaker mechanism, etc. are the same as in the fuel pump used in the Saab 95 and 96. The method of replacing the breaker points and renovating the pump, etc. are the same described in the service manual for the Saab 96.

## GENERAL, BENDIX FUEL PUMP

With effect from chassis number 168001 the Saab "Gran Turismo 850" (Saab Sport) is equipped with a Bendix fuel pump.

The Bendix fuel pump consists of a unit containing a solenoid section, a breaker unit, a pump plunger, valves and a filter. The solenoid section encompasses the plunger, at the lower end of which the outlet valve is situated. The inlet valve is fitted in a special valve housing under the plunger, and is attached to the solenoid housing by three screws. The pump plunger spring rests against the lower section of the valve housing. In the upper end of the pump plunger there is a spring which dampens the plunger movement in the upper position. The pump is equipped with a filter, as well as a magnetic plug for the collection of particles. The filter and magnetic plug are accessible when the bayonet-socketed cap has been taken off.

The breaker unit operates in a hermetically sealed, gas-filled housing which is situated in the upper section of the pump housing. Closing and breaking work magnetically under the influence of the pump plunger.

When the pump plunger is in the upper position the breaker unit is closed and if the ignition is turned on the solenoid coil becomes conductive, whereupon the power attracts the plunger and pulls it downwards, and compresses the plunger spring.

When the plunger moves downwards the fuel is transferred from the underside to the outside of the plunger through the outlet valve. Immediately before the plunger reaches the lowest position the circuit to the solenoid coil is broken, whereupon the plunger spring pushes the plunger back and the fuel above the plunger is forced through the outlet connection to the carburetors. New fuel is transferred through the inlet valve to the underside of the plunger simultaneously. When the plunger reaches the upper position the cycle is repeated.

### NOTE

The pump can only work in one position i.e. with the bayonet cap downwards.





**IMPORTANT**

The Bendix pump gives higher pressure than the SU pump. For this reason the needle valves must always suit the pump, as follows:

Pump	SU	Bendix
Needle valve	1.7 mm	1.5 mm

**CLEANING AND ADJUSTING**

Remove the bayonet cap at the lower end of the pump. Remove the filter and clean it. Wash the cap and gasket in white spirit, and see that the magnetic plug is cleaned of particles.

The breaker mechanism is not accessible for adjusting. If there is any fault in this unit or the solenoid section, the pump housing must be replaced.

**DISASSEMBLY**

Chassis up to -201.400

1. Take off the bayonet cap and remove the gasket and filler.
2. Loosen the three screws which retain the valve housing and remove it. Take care of the gasket.
3. Remove the inlet valve with retainer and spring from the valve housing.
4. Pull out the piston and spring from the pump housing, and inspect the filter inside the plunger.

From chassis No. 201.401

1. Take off the bayonet cap. Remove gaskets, filter and magnetic plug.
2. Let down the locking wire, then remove the washer, the O-ring and the inlet valve from the barrel.
3. Pull out spring and piston with delivery valve.

**ASSEMBLY**

When the parts have been washed and blown clean, and the plunger and valves have been examined regarding wear and sealing properties any defective parts must be replaced and the pump assembled as follows:

Chassis up to 201.400

1. Oil in the plunger sparingly with thin oil, install the plunger spring and push the plunger into the barrel.
2. Fit the inlet valve with spring and retainer into the valve housing.
3. Install the valve housing with gasket and screws into the pump housing and tighten the screws.
4. Put the filter onto the valve housing and fit the bayonet cap and gasket.
5. Test the pump regarding pressure and capacity by connecting it to a testing unit.

From chassis No. 201.401

1. Oil the plunger sparingly with thin oil, install the plunger spring, then push the plunger into the barrel.
2. Fit the inlet valve with spring and retainer into the valve housing.
3. Fit O-ring, washer and locking wire.
4. Put the filter onto the valve housing, and fit the bayonet cap with gasket and magnetic plug.
5. Test the pump in respect to pressure and capacity, by connecting it to a testing instrument.

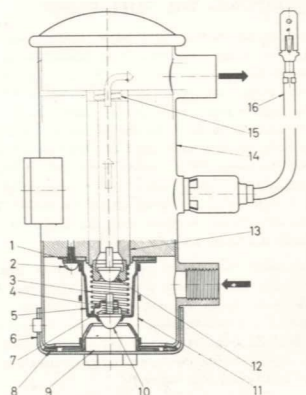

S 720

**Bendix fuel pump up to Chassis 201.400**

- |                    |                  |                           |
|--------------------|------------------|---------------------------|
| 1. Gasket          | 7. Valve spring  | 12. Valve                 |
| 2. Screw           | 8. Gasket        | 13. Plunger               |
| 3. Plunger spring  | 9. Magnetic body | 14. Pump housing          |
| 4. Spring retainer | 10. Valve        | 15. Damping spring        |
| 5. Valve housing   | 11. Filter       | 16. Electrical connection |
| 6. Bayonet cap     |                  |                           |

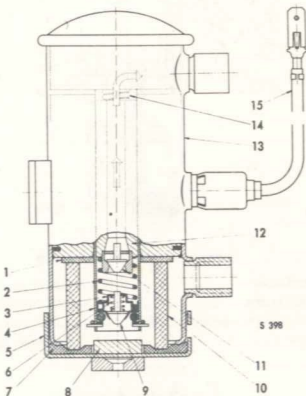

S 398

**Bendix fuel pump from chassis 201.401**

- |                    |                  |                           |
|--------------------|------------------|---------------------------|
| 1. Gasket          | 6. Valve spring  | 11. Valve                 |
| 2. Plunger spring  | 7. Gasket        | 12. Plunger               |
| 3. Spring retainer | 8. Magnetic body | 13. Pump housing          |
| 4. Valve housing   | 9. Valve         | 14. Damping spring        |
| 5. Bayonet cap     | 10. Filter       | 15. Electrical connection |





### INSPECTING THE FUEL PUMP

After breaker points have been replaced or if the fuel pump has been renovated it is advisable to check the pressure height and capacity. This can be done with a simple device, as shown in the illustration. Place a container, with a capacity of about 2 litres (2.1 US qts.), on a plank and above this a holder for the fuel pump. Place a perpendicular pipe, composed of a transparent plastic hose, above the pump. Fit a T-union to the top of the pipe with an adjustable needle valve and a free outlet. A funnel and a return line are fitted under the outlet. The values in the illustration compare with the distances in the car between the tank, pump and carburetors.

When using the device pour white spirit into the container and connect the pump to a battery. Adjust the needle valve to the capacity given in Technical data, with the aid of a litre measure and a clock. The pressure height can then be inspected whilst the pump is operating. The zero capacity pressure height can be checked when the outlet is blocked with a finger.

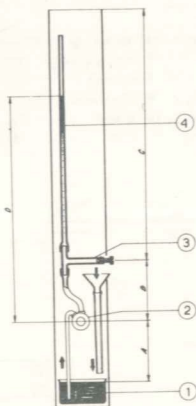

S 137

Testing device for fuel pump

- |                            |                       |
|----------------------------|-----------------------|
| 1. Container               | A = 250 mm (10 in.)   |
| 2. Fuel pump               | B = 250 mm (10 in.)   |
| 3. Adjustable needle valve | C = 2,000 mm (80 in.) |
| 4. Pipe                    | D = Pressure height   |

## Carburetors

### GENERAL

The three down-draft carburetors are Solex 34 BIC carburetors and are fitted to a common inlet manifold, with an inlet to each cylinder. To balance the three carburetors there is a union channel in the manifold casting between the three inlet channels.

The high-speed system consists of a choke tube (K), main jet (Gg), correction jet (a) and emulsion tube (s), which in combination ensure that the carburetor obtains the correct fuel-air ratio in the high speed areas.

The slow-running system is a series-connect bypass system consisting of a pilot air bleed (U), pilot jet (gM) and a volume screw for the fuel-air mixture (W). As well as this there is a volume screw for air in the inlet manifold, which is common to all carburetors. The air to this volume screw comes through a hose from the air cleaner and continues up channels in the inlet manifold to the slow running systems of the three carburetors. The mixing ratio of the slow running system can be varied by the inlet manifold volume screw. The volume screws for the fuel-air mixture on the carburetors (W) are carefully preset at the factory with the aid of a special flow gauge and locked with stop nuts.

#### WARNING

The carburetor volume screws for the fuel-air mixture may not be loosened or readjusted.

On the throttle spindles between the three carburetors there is a connection with adjusting screw for synchronization.

The slow running speed of the engine is set with the throttle screw on each carburetor. Synchronization and slow running settings require precision and access to a special negative pressure gauge called "Synchro-Test".

There is a starter unit on the centre carburetor only, and the fuel-air mixture is distributed to the other cylinders through the balancing channel in the manifold. The starter fuel-air mixture is determined by a starter fuel jet (Gs) and an air jet (Ga). The amount of fuel-air mixture is regulated with a sliding valve which is spring loaded for return from the completely open position to the half open.

The throttle flap may not be opened when starting, as the starter unit then stops functioning.

### DISASSEMBLY AND ASSEMBLY

When it is necessary to remove the carburetors always disconnect the inlet manifold, with the carburetors, from the engine block.

1. Remove the air filter.
2. Disconnect the fuel lines at the pump.
3. Disconnect the rubber boot from the plate on the 1st carburetors throttle spindle.
4. Disconnect the dynamo stay and starter linkage.
5. Release the inlet manifold, with the carburetors, from the engine block.
6. Remove the fuel hoses and carburetors from the inlet manifold. Take care of the companion springs.
7. Clean the carburetor externally and remove the float chamber cover.
8. Inspect the needle valve and gasket.
9. Inspect the float and see that it does not leak and inspect the float spindle and bearing. Clean the chamber.
10. Inspect the main jet, pilot jet, correction jet and emulsion tube.
11. Inspect the starter slide (wear in the surface). Inspect the fuel jet, the air jet and the lever return movement.
12. Inspect the throttle spindle regarding wear.

#### WARNING

The carburetor volume screws for the fuel-air mixture are locked and may not be altered. The adjustment of these screws requires special equipment which is only available at the factory.



- Clean all parts and reassemble the carburetor.
- Fit on the carburetors to the manifold. Fit the companion screws and springs.

**NOTE**

The companion springs are of varying hardnesses. If the throttle control linkage is to operate the forward carburetor (3rd) shall be fitted with the softest spring, the second carburetor has one which is somewhat harder and the coil spring on the control shaft is the hardest (See illustration).

- Fit the inlet manifold, with carburetors, onto the engine block and connect the fuel hoses, dynamo stay and throttle linkage and starter linkage.
- Fit the air filter and warm up the engine. Then carry out synchronization and slow-running adjustments.
- Inspect the float level if necessary.

**ADJUSTING THE FLOAT LEVEL**

The float level is adjusted when the carburetors are installed in the car.

- Keep the engine idling so that the fuel level stabilizes in the float chambers.
- Switch off without moving the throttle linkage.
- Disconnect the fuel hose at the fuel pump so that excess fuel is drained off.
- Remove the air cleaner and float chamber cover.
- Measure the float level with a sliding gauge. The clearance between the float chamber top and the fuel surface should be  $20 \pm 1$  mm (0.78 in.  $\pm 0.04$ ). Note that the carburetor inclines, therefore the measure shall be taken on the wall near the choke tube.
- Adjust the float level if necessary, by filing off the fibre washer under the needle valve or by placing in an extra washer.

**WARNING**

The float lever must not be readjusted. Adjustment must be made with spacers under the needle valve.

- After adjusting check again to ascertain that the required result has been obtained.

**SYNCHRONIZATION AND SLOW RUNNING ADJUSTMENT**

- Warm up the engine.
- Remove the air cleaner and unscrew the companion screws (See the illustration) until they are about 2 mm (0.08 in.) from their fully screwed in position.
- Screw in the volume screw on the manifold and then open  $1\frac{1}{2}$  turn from the closed position.
- Start the engine and set the engine speed provisionally at 600-750 r.p.m. with the aid of the throttle screws.

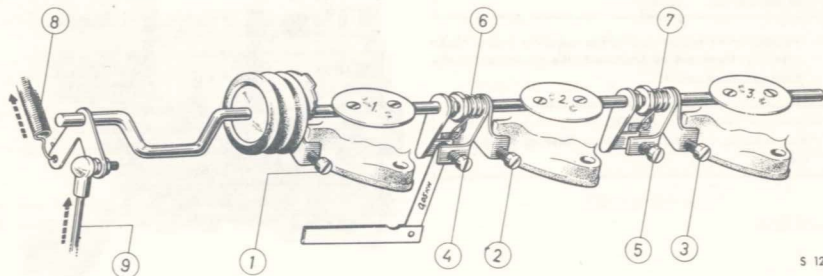

**Throttle linkage**

- 1, 2 and 3. Throttle screws for the respective cylinders
- 4 and 5. Companion screws
6. Hard spring
7. Soft spring
8. Return spring
9. Throttle control



5. Place the Synchro-Test unit on one of the carburetors and adjust the valve of the unit so that the float is in the middle of the sighting glass.
6. Move the Synchro-Test onto the next carburetor and adjust the throttle screw until the same value is obtained. See the illustration.
7. Repeat this on all the carburetors, so that a suitable idling speed (600-750 r.p.m.) is obtained, as the same time as the Synchro-Test unit gives the same reading on all carburetors.
8. Make sure that the volume screw of the manifold gives an idling as even as possible. Adjust it, if necessary 1/2 turn in or out from the original position of 1 1/2 turns.
9. If necessary readjust the idling speed with the throttle screws and recheck with the Synchro-Test unit.
10. Screw in the two companion screws so that they are in their fully screwed in positions with just a little clearance. The clearance should be 0.05 mm. See the illustration.
11. Fit the air cleaner and preheater pipe. Make sure that the hose from the manifold volume screw is placed in the hole of the air cleaner.

### CLEANING THE CARBURETOR

The carburetors need not be removed from the engine for cleaning.

1. Remove the air filter.
  2. Disconnect the fuel lines at the carburetors.
  3. Clean the filters in the carburetors.
  4. Loosen the three screws in the float chamber cover and lift off the cover. Take care of the gasket.
  5. Clean the float valve.
  6. Lift out the float.
  7. Remove the main jet.
  8. Remove the pilot jet.
  9. Remove the starter jet.
- All of these jets are easily accessible.
10. Blow the float chamber, channels and jets clean.

#### WARNING

The carburetor volume screws are locked and must not be altered.

11. Assemble the carburetor, in the opposite order. Make sure that there are no faults with the gasket under the float chamber cover.

#### NOTE

It is suitable to clean fuel pump filter at the same time.

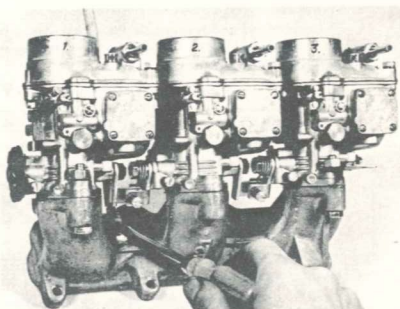

Adjusting the volume screw

S 128

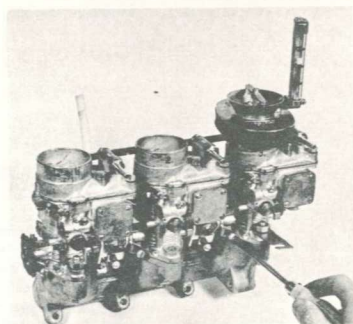

Adjusting the throttle screw with the aid of a Synchro-Test unit

S 129

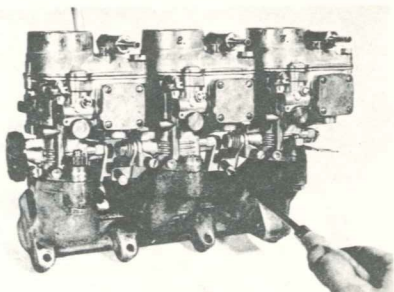

Adjusting the companion screw

S 130



## Air filter

### AIR FILTER AND PREHEATER UNIT

The air filter consists of three separate inserts in a common casing, which also serves as a silencer for the inducted air. The preheater is the same as that for the Saab 96 except that the dimensions are different. The removeable preheater pipe should be fitted to prevent the formation of ice in the carburetors.

#### NOTE

The preheater pipe should only be removed when there are long periods of very warm weather.

### FILTER INSERTS

The replaceable filter inserts should normally be replaced after every 30,000 km. When driving on dusty roads the inserts should be replaced more often. Clean the air filter well internally when replacing inserts. The inserts may absolutely not be washed in kerosene nor oiled in.

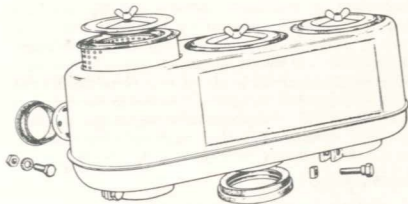

Air filter with insert

## EXHAUST SYSTEM

### GENERAL

The exhaust system is composed of a forward and a rear muffler with an intermediate exhaust pipe. The exhaust pipe is double and has an internal diameter of 34 mm (1.34 in.). The anchorage to the body and connection to the engine are the same as for the Saab 95 and 96. See the illustration.

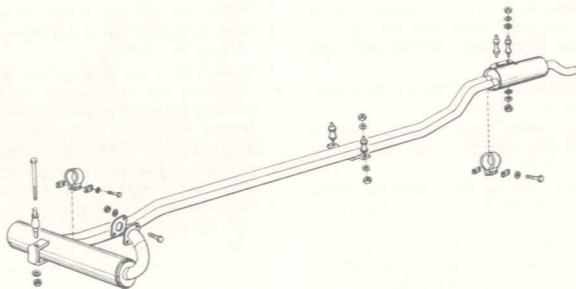

Exhaust system





## Front wheel bearings

### DISASSEMBLY AND REASSEMBLY OF FRONT WHEEL BEARINGS AND OUTER JOINT

After a long period of driving, the car's front wheel bearings may — especially in case of neglected lubrication — prove worn to the extent that play arises. As this highly impairs the steering properties of the car, the bearings must be replaced. Check for play in the wheel bearings in an easy way as follows: raise the car's front end, then seize the wheel at top and bottom, trying to rock it; a may-be play will manifest itself immediately. A play that — at the rim — exceeds 0.08 in. (2 mm) calls for replacement of the wheel bearing. Note that for this work, a press shall be used in addition to the indicated tools needed for disassembly and reassembly of wheel bearings. In no circumstances must the wheel bearings be exposed to blows, as these may damage them.

#### DISASSEMBLY, TYPE I:

1. Remove the hub cap, loosen the shaft nut.
2. Block up the car's front end, remove the wheel and unscrew the shaft nut.
3. Remove the brake housing. This can be done after unscrewing the two bolts on the inside — NOTE! not on the outside — of the housing. The bolts are secured with folded plates. Protect the brake hose from damage by hanging up the brake housing.
4. Pull off the wheel hub, with the brake disk on. Use wheel puller 784002, together with spacer 784129.
5. Disconnect the steering arm and the upper ball joint from the steering knuckle housing.
6. Unscrew the clamp bolt, which holds the lower ball joint to the steering knuckle housing.
7. Pull the drive shaft out of the inner universal joint, and remove the front axle assy., then clean same carefully.
8. Remove nut with shaft seal. Use hook spanner 784020. First break up the nut's locking plate, using a drift or similar.
9. Remove the outer drive shaft by pressing on its threaded end. The outer drive shaft will then be accompanied by joint, rubber bellows and inner drive shaft.
10. Press the bearing out of the steering knuckle housing from the inside.
11. Remove the two sealing rings from their seats in the steering knuckle housing — nut removed — if they need to be replaced.
12. If the joint is to be disassembled, loosen the clamps for the rubber bellows, then remove the rubber bellows.
13. Then seize the inner drive shaft, and knock with a fibre hammer on the drive shaft bell, in this way making the axle's lock ring come loose.

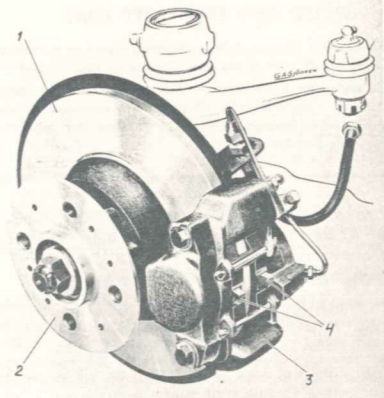

Front axle unit with disc brake

1. Brake disc
2. Hub
3. Brake housing
4. Brake pads

#### DISASSEMBLY, TYPE II:

In universal joints of type II the outer drive shaft has the shape of a bell with spherical grooves, where six balls transmit power from a hub. The inner drive shaft and the hub have splines, and a circlip holds the axle to the hub. As a spare part is available only outer drive shaft, complete, with hub, ball retainers and balls. These parts are matched, and must not be mixed up. Balls are, however, available separately.

1. Remove the hub cap, loosen the shaft nut.
2. Block up the car's front end, remove the wheel and unscrew the shaft nut.
3. Remove the brake housing. This can be done after unscrewing the two bolts on the inside — NOTE! not on the outside — of the housing. The bolts are secured with folded plates. Protect the brake hose from damage by hanging up the brake housing.
4. Pull off the wheel hub, with the brake disk on. Use wheel puller 784002 together with spacer 784129.
5. Disconnect the steering arm and the upper ball joint from the steering knuckle housing.
6. Unscrew the clamp bolt, which holds the lower ball joint to the steering knuckle housing.



7. Pull the drive shaft out of the inner universal joint, and remove the front axle assy., then clean same carefully.
8. Remove nut with shaft seal. Use hook spanner 784020. First break up the nut's locking plate, using a drift or similar.
9. Remove the outer drive shaft by pressing on its threaded end. The outer drive shaft will then be accompanied by joint, rubber bellows and inner drive shaft.
10. Press the bearing out of the steering knuckle housing from the inside.
11. Remove the two sealing rings from their seats in the steering knuckle housing — nut removed —, if they need to be replaced.
12. Then seize the inner drive shaft, and knock with a fibre hammer on the drive shaft bell, in this way making the axle's lock ring come loose.

#### ASSEMBLY TYPE I

All parts must be cleaned and worn or damaged parts must be replaced. Pay special attention to the shaft seals and rubber cuffs.

1. If the seal rings in the steering knuckle housing have been removed, press in new seal rings.
2. Pack the ball bearing with ball bearing grease, see Chapter 19. Only use original bearings.
3. Press the ball bearing into the steering knuckle housing with the number designation on the bearing cup outmost. Use tool 784075.
4. Screw on the nut with the shaft seal and lock the nut.
5. Place spacer ring on the outer drive shaft.
6. Press the shaft into the bearing.
7. Install the outer universal joint with the inner drive shaft.
8. Pack the outer universal joint with chassis or universal grease.
9. Connect the rubber casing to the steering knuckle housing with a hose clamp around the casing.
10. Grease the inner drive shaft with graphite grease or chassis grease and push the shaft in the inner universal joint.
11. Connect the steering knuckle housing to the steering arm and lower ball stud.
12. Fit the hub and brake disc onto the drive shaft.
13. Fit on the washer and shaft nut. Coat the washer with Permatex No. 3.
14. Fit the brake housing. Take care not to damage the brake pads. Lock the bolts with tabs.
15. Fit on the wheel and lower the car.
16. Tighten the shaft nut to a torque of 18 kpm (130 lbs./ft.) and lock with a cotter pin. Fit the hub cap.

#### WARNING

The brake pads must be repositioned close to the brake disk by pumping the brake pedal up and down several times. If this is not done, the brake will not function!

#### ASSEMBLY, TYPE II:

All the parts shall be carefully cleaned, and worn or damaged parts replaced by new ones. Above all, inspect shaft seals and rubber bellows.

1. If the seal rings in the steering knuckle housing have been removed, press in new ones.
2. Pack the ball bearing with ball bearing grease, see chapter 19. Use only Original bearings.
3. Press the ball bearing into the steering knuckle housing, with the number designation on the bearing cup outwards. Use tool 784075.
4. Screw on the nut with shaft seal, and lock the nut.
5. Press in the shaft until it butts against the bearing.
6. Grease the joint with **Universal- or chassis grease containing molybdenum-disulphide (3-5 %)**. The proper quantity (approx. 2 oz=50 g) of grease will be had by filling the bell, and the hub and the balls in it, entirely with grease. Exercise the utmost cleanliness in order to prevent impurities from entering drive joints and bearings.
7. Fit the inner drive shaft in the following way: place the spacer ring on and thereby compressing the circlip. Then push the shaft into the hub.
8. Fit rubber bellows and clamp.

The joints shall be greased every 30,000 miles (50,000 km), and in addition every time when disassembled.

9. Grease the splines of the inner drive shaft with graphite grease or chassis grease, and push the shaft into the inner universal joint.
10. Connect the steering knuckle housing to steering arm and to lower ball joint. Don't forget to fit folded plates at the screws and to secure these.
11. Fit the wheel hub with brake disc onto the drive shaft.
12. Fit washer and shaft nut. Coat the washer with Permatex No. 3.
13. Fit the brake housing. Take care not to damage the brake pads. Lock the bolts with tabs.
14. Fit the wheel, and lower the car.
15. Torque the shaft nut to approx. 130 ft—lb. (18 kpm), and lock with a cotter pin. Fit the hub cap.

#### WARNING

The brake pads must be repositioned close to the brake disk by pumping the brake pedal up and down several times. If this is not done, the brake will not function!

# 12 BRAKE SYSTEM



## Description

### GENERAL

The Saab "Granturismo 850" (Saab 96 Sport) is equipped with disc brakes on the front wheels and drum brakes on the rear. The brake system is manufactured by Lockheed. From Chassis 201.401: The Saab 96 Sport is equipped with a two-circuit system. Concerning description see the workshop manual for the Saab 96.

The following parts are the same as on the Saab 96: Master cylinder, brake lines to rear end, pressure regulating valve, rear backing plate with wheel brake cylinders and handbrake. Descriptions of these parts are found in the workshop manual for the Saab 96.

### DISC BRAKES

The front wheel disc brakes consist of a brake disc, attached to the hub, and which rotates with the wheel. On each side of the disc there is a brake pad which, when braking, is pressed against the disc by a piston. The brake disc is thus squeezed between the two pads. The brake pistons are encased in a divided brake caliper, which surrounds a segment of the disc. The brake fluid is distributed in the brake caliper to both of the brake cylinders, and there is a bleeder screw fitted at the highest point. The brake caliper is bolted to a retainer, attached to the steering knuckle housing.

The pistons have a large diameter — 2". The piston seals are in grooves in the cylinders. The pistons have a completely smooth surface. The outer seal is to prevent the entrance of dust and dirt and the inner seals for brake fluid.

The pistons press directly onto the brake pads, which are kept into position with two springs and cotter pins. The cotter pins and springs are removed when the pads are to be replaced. There are no return springs for the pads, as the disc brakes are self-adjusting.

When brakes are applied brake fluid is transmitted from the master cylinder to the wheel brake cylinders, and the brake pistons press the pads against the disc. When the brake pedal is released the pistons return a few hundredths of a millimetre due to the springing in the piston seal (see the illustration). This return is sufficient to ensure that the pads don't drag on the disc. Wear on the pads is compensated as the pistons move out as the pads are worn down. When the brake pads are worn down it is not possible to see this by an unusually great pedal free travel.

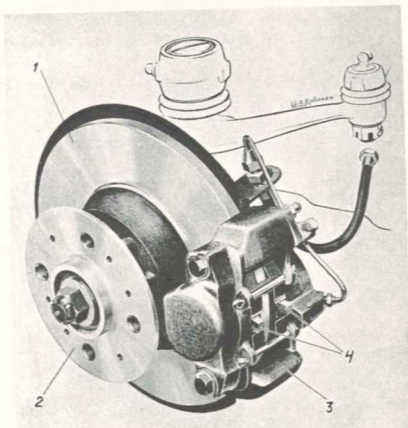

Front axle unit with disc brake

- |               |               |
|---------------|---------------|
| 1. Brake disc | 3. Caliper    |
| 2. Hub        | 4. Brake pads |

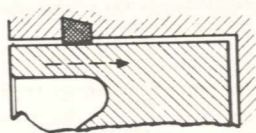
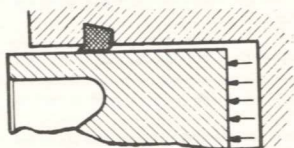

Brake piston pushed back by influence of piston seal





## Disc brakes

### GENERAL

The brake pads must be inspected at regular intervals, at least after every 8000 km (5000 miles). The brake pads must be replaced when 1.5 mm (0.06 in.) lining remains.

The disc brakes are self-adjusting and as the linings wear the pistons come further out, this results in the level of the brake fluid sinking in the reservoir. For this reason the fluid level in the reservoir must be checked regularly.

#### IMPORTANT

Locked Disc brake fluid must be used.

If the brake pedal travel is unusually great, about 2/3 of the distance to the toe-plate, the brake shoes on the rear wheels must be adjusted or replaced.

Brake hoses should be inspected every 15,000 km (9000 miles), regarding leakage or other damage.

The rubber components of the brake system, such as brake hoses, piston seals, etc., should be replaced after 60,000 km (36,000 miles) or every third year.

#### IMPORTANT

The two halves of the caliper should not be separated unless absolutely necessary. All normal service can be carried out without taking them apart.

### REPLACING THE BRAKE PADS

1. Raise the front end of the car and take off the wheel.

#### NOTE

It is unnecessary to remove the caliper from the car or to separate the caliper halves to replace the brake pads.

2. Remove the cotter pins and springs which retain the brake pad. Remove one of the pads. A light twist facilitates removal.
3. Clean the protruding end of the brake piston thoroughly with brake fluid. The piston surface must not be scratched. Make sure that the recess for the pad is free from rust or other deposits.
4. Press the piston back into the caliper with the aid of screw clamp 784132.

#### NOTE

When the brake pistons are pressed back into the cylinders the level in the brake fluid reservoir raises. It is possible that a certain amount of brake fluid must be drained off.

5. Make sure that the brake piston is in the right position, i.e. the recess in the contact surface against the brake pad shall face **downwards**.

#### IMPORTANT

If the brake piston must be turned to the correct position, be careful that the piston sealing area is not damaged.

6. Wash the brake disc thoroughly with tri.
7. Fit the brake pad, and make sure that it goes easily into its recess in the caliper.
8. Replace the other pads in the same way (points 3—7).
9. Fit new springs and cotter pins. Lock the cotter pins.
10. Pump the brake pedal repeatedly, so that the brake pistons come out against the disc.

#### WARNING

Do not forget to depress the brake pedal repeatedly, otherwise there will be no brake action when it is needed.

11. Top up the brake fluid in the reservoir.

### REPLACING THE BRAKE DISCS

When the brake disc, after extensive running, shows signs of bad wear it must be replaced. Reasonably deep scratches do not mean that the disc need be replaced. Unevenness which can be felt when running the finger around the disc in the direction of rotation can, on the other hand, cause excessive wear to the brake pads.

The brake disc may not be turned on a lathe.

The brake disc is replaced as follows:

1. Remove the hub cap and loosen the shaft nut.
2. Block up the front end of the car, take off the wheel and remove the shaft nut.
3. Remove the two bolts which hold the caliper to the steering knuckle housing. The bolts are accessible on the inside of the brake disc.
4. Lift the caliper free of the brake disc, but do not disconnect the brake hose. Be careful that the brake pads are not scratched. Hang up the caliper in such a way that the brake hose is not damaged.
5. Pull off the hub with disc. Use wheel puller 784020 and spacer 784129.
6. Disconnect the disc from the hub.

Fitting is carried out in the reverse order. When fitting the caliper bolts always use a new tab.

#### NOTE

After fitting do not forget to depress the brake pedal repeatedly so that the brake pistons come out against the disc.



# 12 BRAKE SYSTEM



## REMOVING THE BRAKE PISTONS AND SEALS

This operation requires a special screw clamp, Tool No. 784132, see the illustration.

1. Block up the front end of the car and take off the wheel.
2. Take off the cotter pins and springs which retain the brake pads. Remove the pads. A light twist helps with the removal.
3. Remove the two bolts which hold the caliper onto the steering knuckle housing and disconnect the brake line connection at the caliper.
4. Lift off the caliper from the disc.

### NOTE

It is unnecessary to separate the caliper.

5. Clean the caliper externally and dry thoroughly.
6. Connect screw clamp 784132 to one of the brake pistons and push it out with the aid of compressed air in the brake pipe connection. Take care not to drop and damage the piston.

### NOTE

Absolute cleanliness must be observed when the brake piston has been removed, so that no particles nor oil get into the brake system.

7. Use a blunt tool and remove the seal from the cylinder. Do not damage the groove for the seal nor the cylinder.

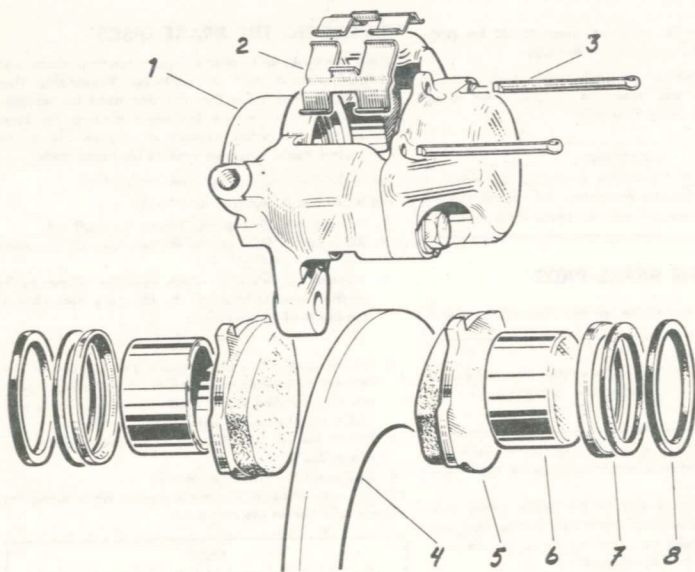

Brake caliper with pistons and pads

1. Caliper
2. Spring
3. Cotter pin
4. Disc
5. Pad
6. Piston
7. Dust seal with retainer
8. Brake fluid seal

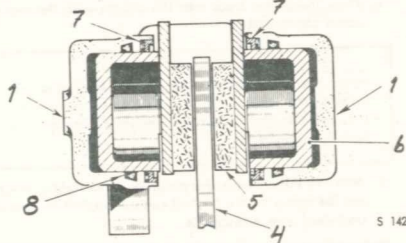



8. If necessary, the outer dust seal can now be removed with a screwdriver.

**IMPORTANT**

When cleaning the brake cylinder only brake fluid or denaturized spirit may be used. Otherwise the seal between the caliper halves can be ruined.

9. When the seals and piston have been refitted (see fitting) the other piston can be removed. The method of removal is the same in the case of both pistons.

**FITTING THE BRAKE PISTONS AND SEALS**

Make sure that all parts are clean and not faulty.

1. Coat a new seal with a special lubricant — Lockheed Disc Brake Lubricant. The seal must be dry before applying the lubricant. Place the seal carefully into its groove, and twist it around with your finger so that it fits in properly.
2. Coat the piston with the same lubricant and fit it so that the recess in the contact surface against the pad faces **downwards**. Push the piston carefully into the cylinder, and make sure that it goes in evenly. To facilitate the fitting of the dust seal do not push the piston right in, leave about 8 mm (0.3 in.) outside of the caliper.
3. Take a new dust seal and lubricate it with the special lubricant. The seal must be dry before lubrication.
4. Place the seal in the cylinder opening and retainer with the countersink side outwards. Press the retainer and brake piston right in with the aid of screw clamp 784132.
5. The brake piston and seal in the other cylinder are fitted in the same way.
6. Connect the brake pipe to the caliper and attach the caliper to the steering knuckle housing with the bolts. Fit on a new tab. Wash the brake disc with tri.

**WARNING**

Do not depress the brake pedal without first opening the bleeder screws.

7. Fit the brake pads and new colter pins and retainer springs.
8. Bleed the brake system and depress the brake pedal repeatedly to adjust the pads against the disc.

**DISASSEMBLY OF CALIPER**

Do not separate the caliper halves unless new bolts, lock tabs and a gasket for the oil channel is available.

The bolts are made of a special material and it is not permissible to use any other type.

**IMPORTANT**

Do not separate the caliper halves unless it is absolutely necessary. All normal service can be carried out on the integral unit.

**REMOVAL**

1. Remove the caliper and remove the brake pads and, if necessary, the brake pistons (see removing the brake pistons).
2. Bend up the lock tabs and unscrew the bolts which keep the caliper together. See the illustration.
3. Separate the caliper and remove the gasket for the oil channel.

**FITTING**

1. If one of the caliper halves has been replaced or the piston removed fit the seal, piston and dust seal (See fitting the brake pistons).
2. Make sure that the sealing surface of each caliper half is absolutely clean, and that the threaded bolt holes are completely dry.
3. Fit a new gasket in the groove at the oil channel, and place the two caliper halves together. Make sure that the gasket is not knocked out of its position.
4. Fit two new bolts and lock tabs (NB. Only special bolts may be used). Make sure that the threads are dry.
5. Tighten the bolts to a torque of 5.2 kpm (37 lbs./ft.).

**IMPORTANT**

Use only Lockheed **Disc Brake Fluid** which is specially made for disc brakes.

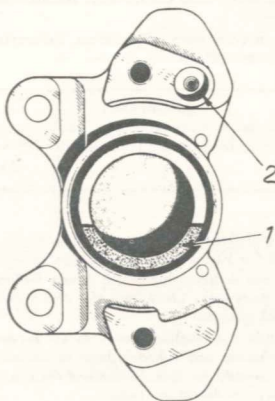

**Brake piston position in caliper**

1. Recess in piston
2. Hole for brake fluid channel gasket

**IMPORTANT**

The threads on the bolts and in the caliper must be completely dry. Lubricated threads cause the bolts to be overloaded. The tightening torque of the bolts, 5.2 kpm (37 lbs./ft.), must be carefully observed.

6. Bend the lock tabs according to the illustration.
7. Mount the brake pads and anchor the caliper with the two bolts to the steering knuckle housing. Fit a new tab.
8. Connect the brake line and bleed the brake system. Depress the brake pedal repeatedly to adjust the pistons and top up the brake fluid in the reservoir.

# 12 BRAKE SYSTEM



## BRAKE FLUID GENERAL

The brake fluid reservoirs should always be kept well-filled. Check the fluid level every 1500 miles (2500 km) or once a month.

It is most important to use the right sort of brake fluid. Inferior brake fluids may completely ruin the hydraulic system, and cause damage to rubber parts. They may also lack lubricating properties and by that initiate corrosion; they may be excessively viscous at low temperatures, or — at the other extreme — have a low boiling point, the latter leads to steam formation in the system at hard braking. This, in turn, disengages the brake — a subsequent catastrophe is possible.

If used for a long time in the system, even the best of brake oils deteriorates by oxidation or water absorption, which lowers the boiling point.

For racing and/or driving in mountain areas shall, for this reason, the brake fluid be replaced by fresh fluid at intervals of one year.

Normally, a full replacement of the brake fluid should be made every third year, or at a mileage of 36,000 miles (60,000 km) — and always when reconditioning the brake system.

In order to prevent water absorption, always keep the brake fluid cans closed.

### IMPORTANT!

Use only brake fluid conforming to Specification SAE 70 R 3, for example Lockheed HD 328 Brake Fluid.

## REFILLING

Before removing the filler cap, wipe clean the reservoir's upper part, in this way preventing dirt from entering when the cap is being taken off. When refilling, care about the paintwork. Check that the vent holes in the cap are not clogged.

If brake fluid consumption proves to be excessive, all lines, connections and cylinders must be inspected with a view to remedy the leak. Throughout the examination, press evenly on the brake pedal.

## REFILLING AFTER DRAINING

When replacing the brake fluid, proceed as follows:

1. Open bleed nipples of both rear wheels, and connect hoses just like when bleeding. Drain the brake fluid reservoir and master cylinder by pumping the brake fluid until air enters the brake system.
2. Fill new brake fluid, and pump the brake pedal until the brake fluid reservoir is almost empty, and at the same time bleed the rear brakes.
3. Fill new brake fluid once more, and open the front bleed nipples. Pump the brake pedal, until the brake fluid reservoir is half-empty; at the same time bleed the front brakes.

4. Then close the bleed nipples, and fill up the brake fluid reservoir.

### NOTE!

Check that approx. the same quantity of brake fluid is drained off at the left-hand and right-hand wheel respectively.

If an inferior-grade fluid has been introduced into the system for any reason, take the following steps at once:

1. Drain the entire brake system.
2. Remove and disassemble master and wheel cylinders.
3. Flush system with methylated spirits.
4. Replace all rubber parts.
5. Reassemble and install cylinders.
6. Fill the system with brake fluid to correct specification.

## BLEEDING THE BRAKE SYSTEM

Bleeding is not a routine matter, and is necessary only when part of the brake system has been removed or brake fluid drained off.

Sure signs that air has entered the system are excessive pedal travel, a springy pedal action, or absence of brake effect until the pedal has been pumped powerfully several times.

Type II and III has a bleed nipple at each brake, and the bleed nipples of the disc brakes are fixed to the inner section of the caliper.

### NOTE!

When a rear wheel brake is being bled, the pressure regulating valve prevents fluid flow to the rear wheels, if the brake pedal is depressed too hard before the bleed nipple is opened.

Jacking up the car makes bleeding of the brake system easier. Proceed as follows:

### TYPE II:

1. Check that the brake fluid container is wellfilled, and that the vent holes in its cap are not clogged.
2. Fit a suitable-sized hose to the brake's bleed nipple.
3. Dip free end of bleed hose in a clean glass jar containing a little brake fluid.
4. Open the nipple.
5. Have an assistant pump the brake pedal with long, even strokes, until the escaping fluid is free of air bubbles. Let the pedal rest a few seconds in its upper position between strokes. Check that all the time the hose end keeps immersed in the jar.



# BRAKE SYSTEM 12

6. Close bleed nipple during a downward pedal movement, or when pedal is fully depressed, than remove hose.
7. Bleed all the brakes in the same way.
8. Check all bleed nipples, and fill system with new fluid. Always discard dirty fluid.

### TYPE III

Proceed the same for type II, except for: The master cylinder has double pistons, and therefore both rear wheels must be bled at the same time.

Start with the rear wheels, then take front wheels.

1. Connect suitable hoses to bleed nipples at both wheels.
2. Dip hose ends in glass jars containing clean brake fluid.
3. Open both nipples  $\frac{1}{2}$ —1 turn.

4. Have an assistant pump the brake pedal — fast downward, slowly upward — until the escaping brake fluid is free of air bubbles. The hose ends shall be kept immersed in the glass jars all the time.
5. Close bleed nipples, keeping the pedal depressed.
6. Check that the brake fluid in the glass jar does not get too low during the bleeding.
7. Fill the fluid reservoir with new brake fluid after both rear and front brakes have been bled.

### NOTE!

Approximately half-way during the pedal stroke a springy pedal action can be noticed, because of the two pressure regulating valves of the two-circuit brake system. This "springing" is normal, and must not be confused with the springing caused by air in the system.

### NOTES



# 15 ELECTRICAL SYSTEM



## GENERAL

The only differences between the electrical system in the Saab "Granturismo 850" (Saab 96 Sport) and that in the Saab 96 are the ignition system and cable net. There is an oil pressure warning relay, to check that the lubrication system is working satisfactorily.

## IGNITION SYSTEM

For the Saab "Granturismo 850" (Saab 96 Sport) shall at hard driving special spark plugs, Champion UK-16V "Surface gap" type be used. These are particularly suitable for two-stroke engines with heavy loading and have a low operating temperature, which among other advantages prevents break downs, such as ignition by incandescence. These spark plugs require high striking voltage, which is obtained by a special ignition coil with series resistance. For normal driving use Champion UK-7 (UK-162) with side electrode. No other types of spark plugs are permitted.

The distributor has no vacuum setting, but has a centrifugally regulated ignition setting, which works with one step.

## CABLE NET

The cable net is built up in the same way as in the Saab 96, but differs regarding cable colours and numbers.

## OIL PRESSURE WARNING RELAY

There is a warning lamp on the instrument panel which glows when the oil pressure in the oil pump, fails. The oil pump is equipped with an oil pressure warning sender which is influenced by the oil pressure and consists of a contact, which opens and closes once per revolution of the pump. The task of the oil pressure warning relay converts the openings and closings of the sender's contact so that the warning lamp is continually dark. If there is no oil pressure the contact is continually closed and the warning lamp glows.

## Ignition system

### DISTRIBUTOR

#### GENERAL

The distributor is manufactured by Bosch and is of type VJ3 BR9T. The method of dismantling and assembly described in the workshop handbook for the Saab 96 also applies on this distributor. The setting values are as follows:

	VJ3 BR9T	VJ3 BR10T VJ3 BR11T
Contact pressure	1100 grammes (39 oz.)	400—530 grammes (14—19 oz.)
Contact clearance	0.3—0.4 mm (0.012—0.016 in.)	0.3—0.4 mm (0.012—0.016 in.)
Dwell angle	80°—84°	77°—83°

The distributor cap is furnished with vent holes and a protective cap under the rotor. The protective cap serves as protection against condensation, so it is important that it seals effectively.

The Saab "Granturismo 850" (Saab 96 Sport) is equipped with a so-called positive ventilation which means that fresh air is pressed through the distributor by means of a ventilation hose from the fresh-air intake. In this way the overpressure of the air prevents water and dirt to come into the distributor.

#### IGNITION REGULATION

The ignition regulation at the various speeds are governed by the centrifugal governor in the distributor. The ignition regulations are according to the graph below.

#### IGNITION SETTING

The order of firing is 1, 2, 3, whereupon 1 is the rear cylinder.

Ignition setting is always carried out on the 2nd cylinder (the centre cylinder).

The ignition is inspected and adjusted with the aid of a stroboscope at an engine speed of 3,000 r.p.m. This is a safer and better method than to set the ignition, with the engine standing still, with a testing lamp.

There is a mark on the pulley, at the front of the engine and three, perhaps only two, marks on the engine block according to the following:

- When the marking on the pulley is opposite the upper mark on the engine block the 2nd piston is in the top dead centre position. This upper mark is to check that the mark on the pulley tallies, and when re-marking the pulley after the crankshaft has been replaced or the pulley.
- When the pulley mark is opposite the centre mark on the engine block the 2nd piston is 10° B.T.D.C. This is the basic ignition position, and is used when setting the ignition on a stationary engine with the aid of a testing lamp, and when installing the distributor.
- When the pulley mark is opposite the lower mark on the engine block, the 2nd piston is 20° B.T.D.C. This is the ignition position at an engine speed of 3,000 r.p.m. and is used for ignition setting with the aid of a stroboscope. Note here that the engine speed shall be increased from idling and above the speed when the ignition regulation is carried out.

#### SETTING VALUES

Model	Distributor		
	Bosch designation	Contact clearance	Dwell angle
Sport Saab 96	VJ3 BR9T	0.3—0.4 mm (0.012—0.016 in.)	80—84°

Model	Basic ignition position with stationary engine	Ignition position at 3,000 r.p.m. Setting with a stroboscope
	Degrees on crankshaft B.T.D.C.	Degrees on crankshaft B.T.D.C.
Sport Saab 96	10°	20°



### IGNITION SETTING WITH A STROBOSCOPE

1. Inspect the breaker points and the breaker arm, and adjust to the correct contact clearance. When fitting a distributor rotor always use a new spring washer so that the screw is effectively locked. Inspect and clean the distributor cap, ignition coil, ignition cables, spark plugs and the terminals at the plugs and distributor. Make sure that the ignitions are not nearer the casting than about 10 mm (0.4 in.) at any point.
2. Turn over the crankshaft so the mark on the pulley is opposite the centre mark on the engine block (The upper mark if there are only two marks).
3. Fit the distributor so that the rotor marking is opposite the mark on the edge of the distributor housing, and so that the lubricator comes forward.
4. Connect the stroboscope to the 2nd cylinder ignition cable and start the engine. Increase the engine speed successively. A clear alteration in the ignition position will be noticed at 1,000—1,500 r.p.m. When the engine speed is increased further the ignition position is constant. The ignition setting is carried out in this range by turning the distributor. When the mark on the pulley coincides with the **lower** mark on the engine block the distributor is locked with the lock screw.

### IGNITION SETTING WITH A TESTING LAMP

If there should be no stroboscope available the ignition setting can be carried out with the aid of a testing lamp which is connected between the casting and the connection for the low-tension cable in the distributor.

1. Remove the distributor cap, rotor and protective cap. Inspect the breaker points and adjust the contact clearance.
2. Fit on the protective cap and rotor. Use a new lock washer so that the screw is effectively locked.
3. Turn over the crankshaft so that the mark on the pulley coincides with the centre mark on the engine block.
4. Fit the distributor so that the marking on the rotor is opposite the mark on the edge of the distributor housing, and so that the lubricator points forwards.
5. Connect a testing lamp between the casting and the connection for the low-tension cable on the distributor, and turn on the ignition.
6. Turn the distributor and find the position where the testing lamp glows. Make sure that the centrifugal weights are in by turning the rotor anticlockwise. Lock the distributor by screwing in the lock screw.
7. Make sure that the adjustment is correct by turning over the crankshaft clockwise one turn. When the mark on the pulley comes opposite the **centre** marking on the engine block the testing lamp shall glow. Make sure that the marks on the rotor and housing edge coincide and that the weights are in.
8. Turn off the ignition and remove the testing lamp. Clean and inspect the distributor cap, ignition cables, spark plugs and the terminals at the plugs and distributor cap.

### INSPECTION AND MARKING OF IGNITION SETTING MARKS ON THE PULLEY

#### IMPORTANT

If the crankshaft or pulley have been replaced, the marking on the pulley will not agree.

The inspection or marking of the pulley is carried out as follows:

1. Fit the indicator gauge (tools 784040, 784060 and 784062) in the spark plug hole for the 2nd cylinder.
2. Turn over the crankshaft until the piston is at top dead centre, which can be ascertained with the indicator gauge.
3. The marking on the pulley shall coincide with the **upper** mark on the engine block. If it does not the old marking must be filed off and a new mark made, with a file.

### IGNITION COIL AND IGNITION CABLES

There are two different makes of ignition coils; one with and one without an armoured cable to the ignition switch. The ignition coil is situated on the wheel valance, and is furnished with a pre-connection resistance to protect the coil at low engine speeds or when the engine is stationary with the ignition switched on.

The ignition cables are equipped with terminals at the plugs and distributor, to facilitate effective sealing. The terminals at the plug ends must have a vent hole. The holes are situated towards the radiator.

#### IMPORTANT

The ignition cables must not lie nearer than about 10 mm (0.4 in.) to the casting at any one point.

### SPARK PLUGS

#### Champion UK-16V for hard driving

The spark plugs, which are of the "Surface gap" type, have no side electrodes. The spark gap is the clearance between the centre electrode and the lower part of the plug body. It is thus not possible to adjust the spark gap. When the gap exceeds 1.2 mm (0.05 in.) the plugs must be replaced.

The plug must not be air-blast or washed in gasoline or the like. When cleaning a wire brush can be used and plug then blown clean by air-blasting.

To obtain a spark with a greater effect the plug is equipped with a pre-spark gap inside the insulator. This area is ventilated through the screw for the cable connection. See the illustration. To prevent corrosion in the terminal, it is equipped with a vent hole, which faces backwards.

#### Champion UK-7 (UK-162) for normal driving

These spark plugs have side electrodes. The spark gap shall be 0,8 mm (0.032 in.).

#### IMPORTANT!

The tightening torque for the Champion UK-16V spark plugs is 2 kpm (14.4 lbs./ft.) and for Champion UK-7 (UK-162) 4.5 kpm (32.4 lbs./ft.).

The above mentioned spark plugs are only sold by SAAB agents.

The ignition voltage is relatively high, which places great demands on the fact that distributor cap, ignition coil, ignition cables and plugs are kept clean. The ignition cables must at no point lie nearer than 10 mm (0.4 in.) to the casting.



**Cables and fuses**

**ELECTRICAL SYSTEM UP TO CHASSIS 168.000**

The electrical system for the Saab "Granturismo 850" (Saab 96 Sport) (up to chassis 168.000) is shown on the wiring diagram on the next page. The table below shows the colours of the various cables so that they can easily be identified.

Cable colours:

Black:	1, 7, 18, 19, 20, 23a, 24a, 32, 37, 45, 46, 47, 48, 49, 71, 80, 88, 89, 105, 107, 108, 109, 120, 122
Red:	5, 8, 9, 10, 11, 14, 15, 21, 27, 28, 33, 34, 39, 61, 63, 65, 67, 68, 72, 83, 86, 90, 111, 116
Yellow:	17, 25a, 26a, 43, 44b, 66, 73, 81, 84, 99, 100, 112
Green:	16, 22, 50, 51, 52, 53, 54, 55, 56, 57, 58, 60, 75, 82, 101, 102, 103, 119
Blue:	42a, 62
Grey:	4, 12, 25b, 26b, 29, 35, 36, 38, 44a, 64, 69, 70, 74, 85, 92, 93, 94, 113, 114, 117
White:	23b, 24b, 30, 40, 41, 42b, 95, 96, 97, 98, 115

**Legend of the circled figures on the wiring diagram**

- |                                |   |
|--------------------------------|---|
| 1. Parking lamps-flashers      | 23. Lighting switch                           |
| 2. Headlamps                   | 24. Fan switch                                |
| 3. Horn                        | 25. Flasher relay                             |
| 4. Fog and spot lamps          | 26. Windshield wiper switch                   |
| 5. Distributor                 | 27. Ignition and starter switch               |
| 6. Spark plug                  | 28. Cigarette lighter                         |
| 7. Generator                   | 29. Switch for back-up lamp with warning lamp |
| 8. Fuel pump                   | 30. Switch for fog lamps                      |
| 9. Starter motor               | 31. Instruments lighting switch               |
| 10. Battery                    | 32. Switch for spot lamp                      |
| 11. Charging relay             | 33. Direction indicator switch                |
| 12. Fusebox                    | 34. Horn contact                              |
| 13. Resistance                 | 35. Interior lamp with switch                 |
| 14. Ignition coil              | 36. Fuel gauge sender                         |
| 15. Fan motor                  | 37. Flasher and tail lamp                     |
| 16. Windshield wiper motor     | 38. Back-up lamp                              |
| 17. Windshield washer pump     | 39. Number plate illumination                 |
| 18. Brake contact              | 40. Oil pressure warning sender               |
| 19. Foot-dipper switch         | 41. Oil pressure warning relay                |
| 20. Instruments                | 42. Search lamp relay                         |
| 21. Warning lamp, oil pressure |   |
| 22. Door switch                |   |





# 15 ELECTRICAL SYSTEM



## ELECTRICAL SYSTEM FROM CHASSIS 168.001 UP TO CHASSIS 201.400

The electrical system of the Saab "Granturismo 850" (Saab 96 Sport) is shown in the adjacent wiring diagram. The cable numbers refer to the following table, by which the various cables may be identified.

Cable insulation colors:

Black:	1, 7, 18, 19, 23a, 24a, 32, 45, 46, 47, 48, 49, 71, 80, 88, 105, 106, 107, 108, 109, 120, 122, 124, 125
Red:	5, 8, 9, 10, 11, 14, 15, 20, 21, 27, 28, 33, 39, 61, 63, 65, 67, 68, 72, 83, 86, 111, 116, 126, 129, 132
Yellow:	17, 25a, 26a, 30, 43, 44b, 66, 73, 81, 84, 99, 100, 112, 128b, 130
Green:	16, 22, 50, 51, 52, 53, 54, 55, 56, 57, 58, 60, 82, 101, 102, 103, 104, 110, 119, 133
Blue:	42a
Grey:	4, 12, 13, 25b, 26b, 29, 35, 44a, 62a, 62b, 64, 69, 70, 74, 75, 85, 89, 113, 117, 127
White:	23b, 24b, 40, 41, 42b, 95, 97, 98, 115, 128a, 131

### Legend of the circled figures on the wiring diagram

- |                                      |  |
|--------------------------------------|--|
| 1. Turn indicators and parking lamps | 23. Headlight switch with panel light switch |
| 2. Headlights                        | 24. Heater fan switch                        |
| 3. Horns                             | 25. Flasher unit                             |
| 4. Fog light and spot light          | 26. Windshield wiper switch                  |
| 5. Distributor                       | 27. Ignition and starter switch              |
| 6. Spark plugs                       | 28. Cigarette lighter                        |
| 7. Generator                         | 29. Back-up light switch                     |
| 8. Fuel pump                         | 30. Fog light switch                         |
| 9. Starter                           | 31. Spot light switch                        |
| 10. Battery                          | 32. Turn indicator switch                    |
| 11. Relay                            | 33. Horn push                                |
| 12. Fuse box                         | 34. Courtesy light with switch               |
| 13. Resistance                       | 35. Tank unit, fuel gauge                    |
| 14. Ignition coil                    | 36. Turn indicators and tail lamps           |
| 15. Heater fan motor                 | 37. Back-up light                            |
| 16. Windshield wiper motor           | 38. License plate lights                     |
| 17. Windshield washer pump           | 39. Oil gauge                                |
| 18. Stop light switch                | 40. Relay, oil gauge                         |
| 19. Beam switch                      | 41. Relay, spot light                        |
| 20. Instrument unit                  | 42. Luggage compartment light                |
| 21. Oil pressure control light       | 43. Temperature meter                        |
| 22. Courtesy light switch            |  |



235  
**ELECTRICAL SYSTEM 15**

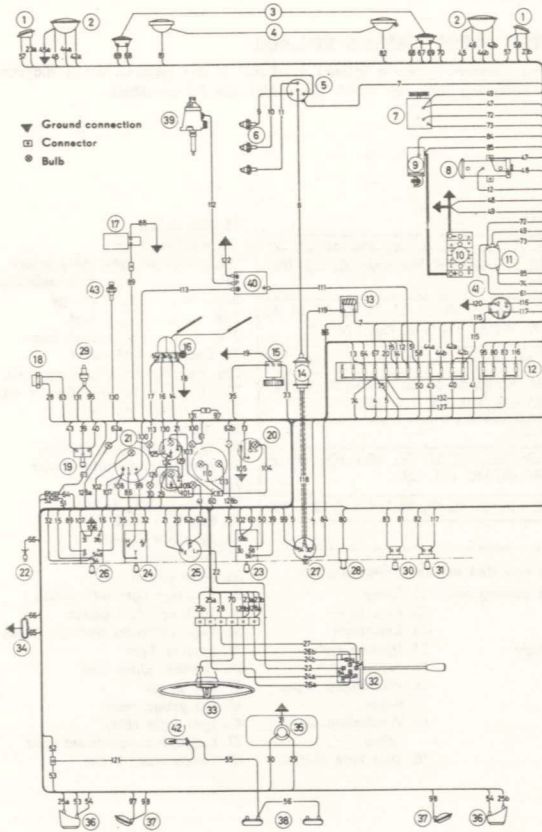

S 235

Wiring diagram from chassis 168.001 up to chassis 201.400

# 15 ELECTRICAL SYSTEM



## ELECTRICAL SYSTEM FROM CHASSIS 201.401

From chassis 201.401 the electrical system is altered as shown in the adjacent wiring diagram. The cable numbers refer to the following table by which the cables can be identified.

### Cable insulation colours:

Black:	1, 7, 7b, 18, 19, 23a, 24a, 32, 45, 45a, 46, 47, 48, 49, 71, 80, 88, 105, 106, 107, 108, 109, 120, 122, 124, 125, 135.
Red:	5, 8, 9, 10, 11, 14, 15, 20, 21, 27, 28, 33, 39, 61, 63, 65, 67, 68, 72, 83, 86, 111, 116, 126, 129, 132.
Yellow:	17, 26a, 43, 44b, 73, 81, 84, 99, 100, 112, 128b, 130.
Green:	16, 22, 50, 51, 52, 53, 54, 55, 56, 57, 58, 59, 60, 82, 101, 102, 103, 104, 110, 119, 121, 133.
Blue:	13, 25a, 41, 42a.
Gray:	4, 12, 13, 25b, 26b, 29, 35, 44a, 62a, 62b, 64, 69, 70, 74, 75, 85, 89, 113, 117, 127.
White:	23b, 24b, 40, 42b, 66, 95, 97, 98, 115, 118, 128a, 131.
Brown:	30.

### Key to the numbers encircled on the wiring diagram

- |                                       |                            |  |
|---------------------------------------|----------------------------|--|
| 1. Turn indicators and parking lights | 11. Relay                  | 19. Dip switch   |
| 2. Headlights                         | 12. Fuse box               | 20. Instrument unit                                      |
| 3. Horns                              | 13. Resistance             | 21a. Indicator light, oil pressure                       |
| 4. Fog light and spotlight            | 14. Ignition coil          | 21b. " " , turn indicators                               |
| 5. Distributor                        | 15. Fan motor              | 21c. " " , charge  |
| 6. Spark plugs                        | 16. Windshield-wiper motor | 21d. " " , fuel  |
| 7. Generator                          | 17. Windshield-washer pump | 21e. " " , high beam                                     |
| 8. Fuel pump                          | 18. Stop light switch      | 22. Courtesy light switch                                |
| 9. Starter                            |                            | 23a. Headlight and parking light switch                  |
| 10. Battery                           |                            | 23b. Rheostat for intensity of instrument panel lighting |
|                                       |                            | 24. Ventilator fan switch                                |
|                                       |                            | 25. Flasher unit   |
|                                       |                            | 26. Windshield-wiper switch                              |
|                                       |                            | 27. Ignition and starter switch                          |
|                                       |                            | 28. Cigarette lighter                                    |
|                                       |                            | 29. Back-up light switch                                 |
|                                       |                            | 30. Fog light switch                                     |
|                                       |                            | 31. Spotlight switch                                     |
|                                       |                            | 32. Turn indicator switch                                |
|                                       |                            | 33. Horn button  |
|                                       |                            | 34. Courtesy light with switch                           |
|                                       |                            | 35. Tank unit fuel gauge                                 |
|                                       |                            | 36. Turn indicators and tail lamps                       |
|                                       |                            | 37. Back-up light  |
|                                       |                            | 38. Number plate light                                   |
|                                       |                            | 39. Oil gauge  |
|                                       |                            | 40. Oil gauge relay                                      |
|                                       |                            | 41. Spot light relay                                     |
|                                       |                            | 42. Luggage compartment light                            |
|                                       |                            | 43. Temperature meter                                    |

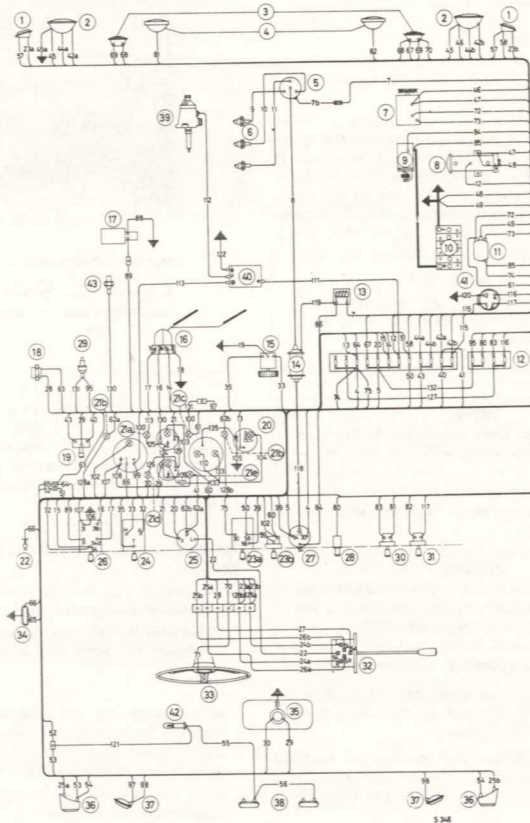

Wiring diagram from chassis 201.401



# 15 ELECTRICAL SYSTEM



## Oil pressure warning system

### GENERAL

The oil pressure warning system consists of a sender, a relay and a warning lamp.

The task of the warning relay is to ignite the lamp on the instrument panel when an impulse is obtained from the sender on the pump showing that the engine lubrication system is not functioning.

The relay is composed of a box containing two bimetal relays, one for voltage control and one for the sending of signals. See the illustration.

The relay has a certain delay and requires a certain number of impulses from the pump before the lamp on the instrument panel goes out. This time can vary from 15 seconds to 1½ minutes, dependent on how the car is being driven. When driving a long time on low idling speed the lamp can flash. However this should disappear when the engine has run for a while above idling speed.

#### NOTE

The warning lamp can be alight up to 1½ minutes without there being something wrong with the lubrication system.

#### NOTE

It is not possible to make adjustments to the relay. If there is anything wrong with it, it must be replaced.

The warning relay is connected according to the wiring diagram in section 4.

#### WARNING

Both the sender and the relay can be ruined if the cable from the sender is faultily connected to the relay. The cable shall be connected to "P".

### INSPECTING THE OIL PRESSURE WARNING SYSTEM

Make it a habit to check periodically that the system operates satisfactorily. This can be done with a watch with a second-hand, as follows:

1. Switch on the ignition, and see that all electrical appliances are turned off. The warning lamp should start glowing immediately, and go out after 15–30 seconds.
2. After 1–1½ minutes, from switch-on, the lamp should start glowing again.

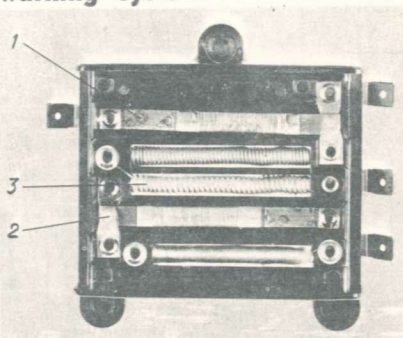

Disassembled oil pressure warning relay S 157

1. Bimetal relay for warning lamp
2. Bimetal relay for voltage control
3. Resistance

#### NOTE

The above only applies if the voltage between the relay connections for + and the casing is at least 12.5 V, i.e. the battery must be fully charged, no electrical appliances may be turned on and there must be no transitory resistance in the cables and terminals.

### TROUBLE FINDING IN THE OIL PRESSURE WARNING SYSTEM

If the warning lamp does not operate as described above the following investigations must be made:

1. Disconnect the cable to the sender on the pump and reconnect to ground. Wait a minute or so, so that the relay has time to cool and re-inspect as described above. If the warning lamp functions the fault is probably in the sender on the pump, which can be inspected according to Chapter 3 section 11.
2. Make sure that the fuse is alright and that the fuse holders have not oxidized.
3. Ascertain that the warning lamp is not faulty.
4. Make sure that the cables and connections are free of faults and that good contact is obtained.
5. If the oil pressure warning system still does not function satisfactorily, when re-inspecting according to above, the relay must be replaced.



## Lubricating instructions

### GENERAL

The length of life of the car is greatly dependent on lubrication. Lubrication correctly carried out ensures that the car runs quietly and evenly and prevents unnatural wear to the moving parts. Each lubrication point must be lubricated regularly with first-class lubricant. The lubrication chart and lubrication table show where the points are located and recommends certain lubricants. The usual intervals between lubrication are divided up between stretches of 1,500 km (1,000 miles), 3,000 km (2,000 miles),

and 12,000 km (8,000 miles). From the model 1964, 2,500 km (1,500 miles) 5,000 km (3,000 miles) 15,000 km (9,000 miles). Besides, there are a few points which shall be lubricated every 25,000 km (15,000 miles) and 50,000 km (30,000 miles), such as wheel bearings, etc.

When lubricating, and with other work, cleanliness is imperative, so that the body and equipment are not spotted with grease. When greasing the ball joints on the front end, the car should be blocked up so that the wheels hang free.

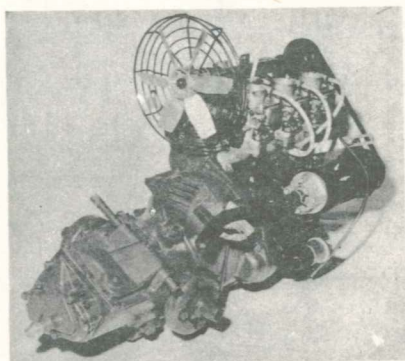

Power unit



LUBRICATION CHART SAAB "GRANTURISMO 850"  
(SAAB-96 SPORT)

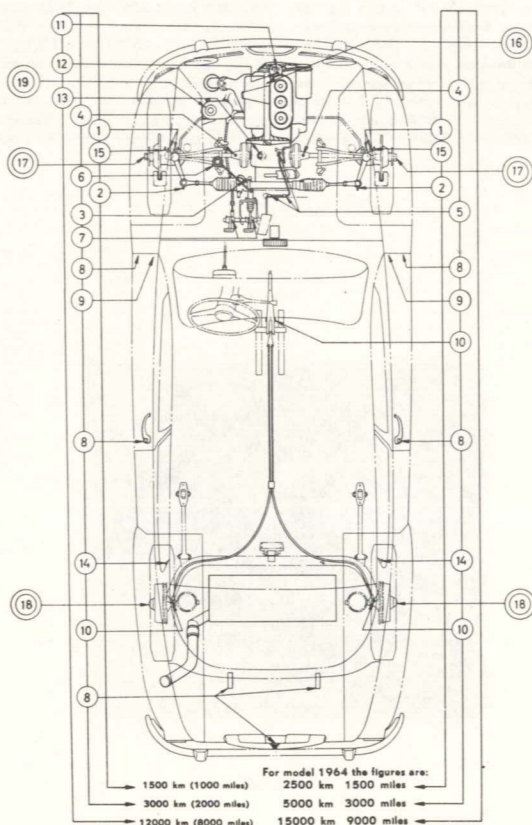





# 19 LUBRICATION AND SERVICE



## DIFFERENCE FROM THE SAAB 96

The lubrication intervals and points are the same as on the Saab 96, with the following exceptions.

### DISTRIBUTOR GEAR

The distributor gear has no lubricating nipple, and is lubricated automatically from the oil pump. If the engine is disassembled, however, 50 cm<sup>3</sup> (3 cu.in.) of oil must be poured into the distributor gear housing.

### ENGINE

The Saab 96 Sport is separately lubricated which means that only gasoline shall be filled into the fuel tank. Premium fuel of at least 95 octane shall be used. Oil is filled into a tank in the engine housing. This tank contains about 3 litres (0.8 US gal.), which is sufficient for at least 1,500 km (1,000 miles) of normal running.

The following oils are recommended:

Warm climate: Two-stroke oil SAE 30—40 (also self-mixing).

If there is no two-stroke oil available HD oil SAE 30—40 can be used.

Cold climate with an exterior temperature of

less than 14° F (—10° C): Self-mixing two-stroke oil, e.g. oil which has been diluted by the manufacturer.

If the car is left outside in cold climates where the temperatures are less than 14° F (—10° C) the oil can become so thick that the oil pump cannot operate satisfactorily. This risk is eliminated if the oil is self-mixing. NB. Multi-grade oils with a viscosity of SAE 10W—30 may not be used.

## 2. SERVICE

### GENERAL

The delivery and service inspections specified in the Saab 96 handbook also apply for the Saab 96 Sport, with the following exceptions and additions

#### SPARK PLUGS

The spark gap cannot be adjusted on the Champion UK-16 V spark plugs. Inspect and clean with a wire brush and air-blasting. When the spark gap exceeds 1.2 mm (0.05 in.) the plugs must be replaced.

#### ADJUSTING THE IDLING

The idling speed can only be adjusted in conjunction with the synchronization of the carburetors, which requires access to a "Synchro-Test". See Chapter 6, section 4.

#### INSPECTING THE OIL PRESSURE WARNING UNIT

Make sure that the sender and relay function properly each time the car is serviced. See Chapter 15, section 5.

#### FUEL PUMP

If the car is equipped with a Bendix fuel pump, only the filter shall be cleaned.

### NOTES

NOTES

NOTES

NOTES



NOTES

NOTES

NOTES

NOTES



NOTES

NOTES

NOTES

NOTES



NOTES

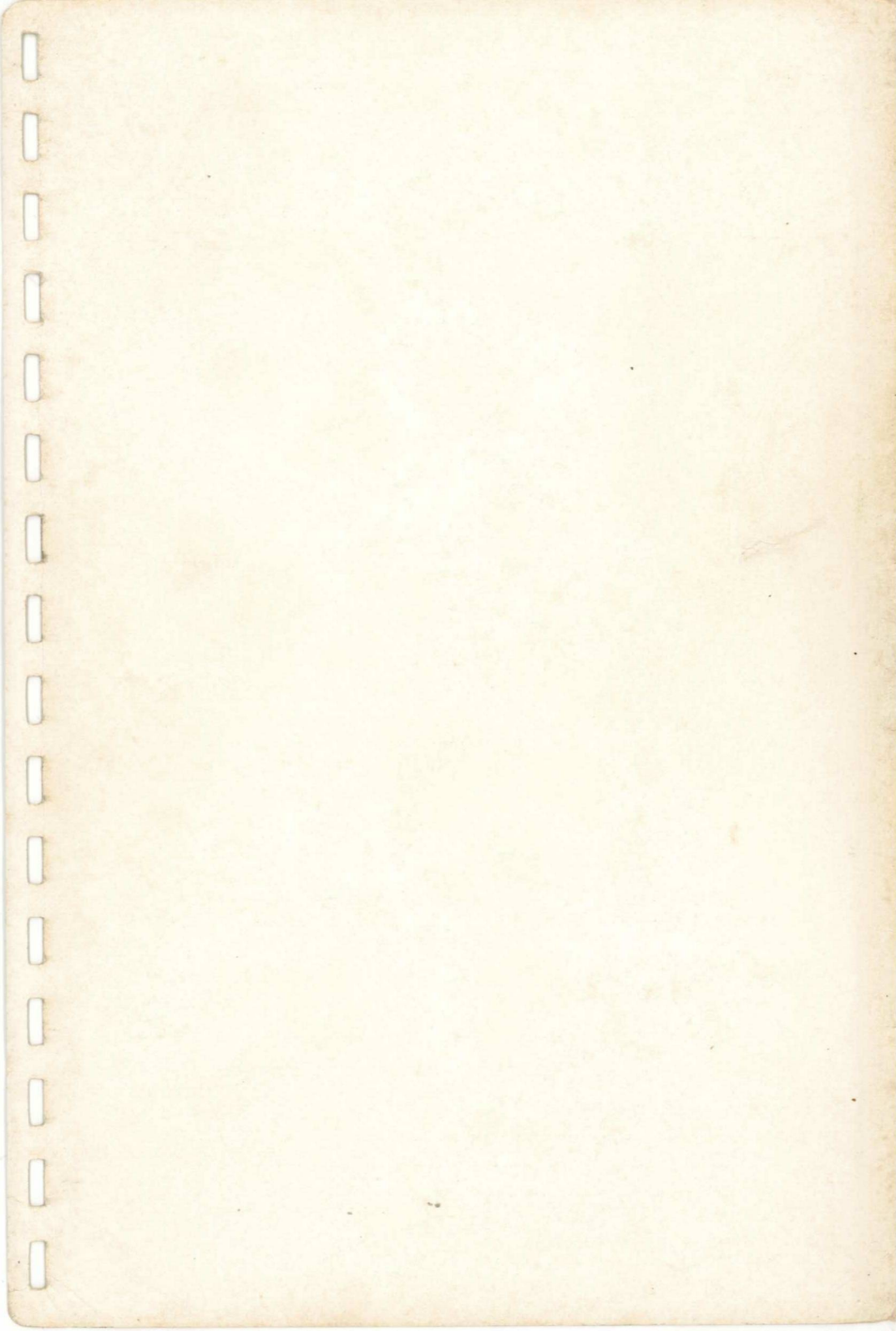



REVISED, NOVEMBER, 1964