

#274

March/April

2005

# Nines

The Saab Club Magazine

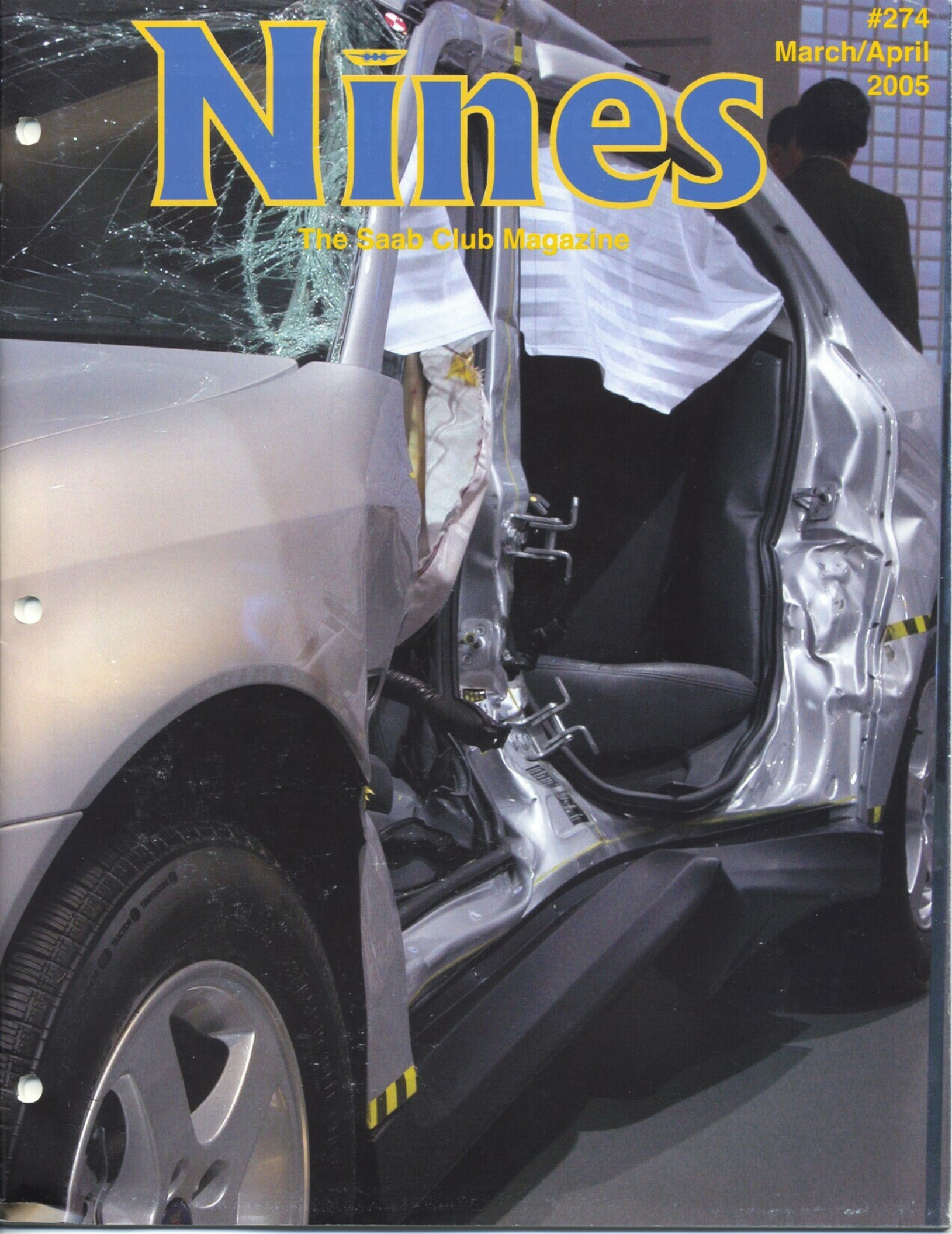

# www.andrewsofprinceton.com

*Andrews Inc. of Princeton*

Home of Andrews Certified, Quality Checked and Program Pre-owned Saab



**GOLDWING**  
SAAB PARTS WAREHOUSE

1-800-SAAB-137  
www.goldwingsaab.com

TEL: 315-625-7969 FAX: 315-625-4862  
P.O. BOX 315, ROUTE 11, HASTINGS, NY 13076

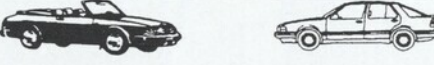

**SAAB**  
SERVICE & REPAIR

JERRY SWEET  
973-252-5151

Sweet Motors  
379 U.S. Highway 46  
Mine Hill, NJ 07803



**SWEDISH CAR SERVICE, LLC**  
261 WEST UNION AVE. (RT. 28)  
BOUND BROOK, NJ 08805

TIBOR AMBRUS  
CERTIFIED SAAB TECHNICIAN

PHONE: (732) 564-1000  
FAX: (732) 564-1001

**If we can't fix your SAAB no one can.**

35 Years of SAAB service specializing in locating hard to find parts. Call us when your SAAB needs expert care.



## REINERTSEN SAAB of DENVILLE

**973 627 0616** | 295 Route 53, Denville, NJ 07835 [www.rmisaab.com](http://www.rmisaab.com)



**Scanwest Autosport**

New, used & performance parts

Exclusive U.S. Distributor for **abbott racing** MOTORSPORT

[www.scanwestauto.com](http://www.scanwestauto.com)

T: 206-789-2819 Fax: 206-781-5281 1-888-90TURBO  
9520 Greenwood Avenue North - Seattle, Washington 98103

**SAAB** Right Solutions, Inc.  
Los Angeles, CA

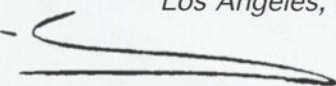
  
**Walter Wong**

Factory Trained  
Tech II Diagnostics

See our ad on Page 39!

310-666-2406 [saabtech@pacbell.net](mailto:saabtech@pacbell.net)  
8577 Venice Blvd.



**SAAB**

All Recycled Saab Parts  
93B, 95, 96, 99, 900, 9000



East West Auto Parts, Inc  
4605 Dawson Road  
Tulsa, OK 74115-4102

800-447-2886

or (918) 832-7077

FAX (918) 832-7900

website: [www.eastwestautoparts.com](http://www.eastwestautoparts.com)

## Editor and Publisher:

Seth D. Bengelsdorf

**Managing Editor:** Diana Schaefer

### Contributing editors and photographers:

Chuck Andrews, Jack Ashcraft, Mike Blija, C. Calhoun, Thor Carlson, Todd Ench, Stephen Goldberger, Bruce Harbison, Linnea Krajewski, William C. W. Lamb, John Mackay, John Moss, Alan Snelson Stefan Vapaa.

### All material copyright 2005, SB Productions.

Material may not be reused or reproduced without permission. If permission is granted, credit MUST include the author's name and "NINES, The Saab Club Magazine." The opinions and views expressed in the articles in this magazine are not necessarily those of the Saab Club or its magazine, NINES.

### Editorial contributions are always welcome.

All material submitted is assumed to be for publication unless clearly labeled otherwise. Computer-ready formats are preferred. Although we try, we cannot answer every inquiry and reserve the right to edit at our discretion materials submitted. E-mail submissions are preferred; we are able to translate and read most word processor formats.

### Photos:

Preferred sizes are 5" x 7" or larger. Good contrast color photos or full range black-and-white photos can be accommodated, no smaller than 3" x 5" please. Photos used on the cover will be rewarded with a one-year subscription to NINES and must be submitted in 8" x 10" format with the original negative or transparency, or as a TIFF file with 300 dpi resolution at a minimum at our 8<sup>1/2</sup>" x 11" cover size. For return of photos, please include a SASE of correct size and affix sufficient postage.

**CHANGE OF ADDRESS:** Eight weeks' notice is required. PLEASE mail new address and old address, including zip codes, to the Saab Club at the address below, or fax or e-mail the same information.

**RETURNED CHECKS:** There will be a fee of \$25 charged for any returned checks.

### NINES, The Saab Club Magazine

(ISSN 1530-0730 issued November, 2004.)

Published bimonthly by SB Productions of Port Chester, NY.

#### SB Productions

30 Puritan Drive

Port Chester, NY 10573-2504

Phone: 914-937-6075

E-mail the editor: nineseditor@earthlink.net

E-mail the publisher: ninespublisher@earthlink.net

Web site: www.saabclub.com

The Saab Club is not affiliated in any way with Saab Cars USA, Inc. or Saab Automobile AB.

**SUBSCRIPTION RATE** is \$30.00 per year in the U.S. Please see the form on the inside cover wrap for complete information.

**Periodicals Postage Paid** Port Chester, NY and at additional mailing offices.

**POSTMASTER:** Send address changes to NINES, 30 Puritan Drive, Port Chester, NY 10573-2504.

## Features

From The Archives .....	6
Saab Racing History .....	6
The End Of An Era .....	7
Changing The Cabin Fan On A Classic 900 .....	8
The Aero Academy .....	14
My Saab 900, Beginning To End .....	22
The North American International Auto Show .....	24
Saab In 2005 .....	32
Good Bye Older Friend .....	34

## Saab Clubs

SCNA News .....	10
North American Saab Clubs And Contacts .....	11
North American Saab Club Discounts .....	12
Saabtoberfest 2004 .....	13
Club News .....	17
Starting A Local Saab Club .....	20
Photo Round-up .....	37

## Departments

Letters .....	4
Professional Perspective <i>by Chuck Andrews</i>	
Is Saab To Blame? .....	18
On The Column <i>by William "Chip" Lamb</i>	
Dear Chip .....	21
Shoptech <i>by Jack Ashcraft</i>	
PCV Valve Systems - V4, Part 3 .....	28
Holy Saab <i>by C. Calhoun</i> .....	30
Has Your Saab Embarrassed You Lately? <i>by Linnea Krajewski</i> .....	36
Classified Ads .....	38

**Front Cover:** The Insurance Institute for highway Safety loaned Saab the actual side impact test car - displayed at Saab's North American International Auto Show stand in Detroit. Story on Page 24. *Photographed by Seth D. Bengelsdorf.*

**Cover Wrap:** Tired of winter? Here's a Saab that awaits a shovel, or a warming trend. *Photographed by Ted Yurkon.*

**Big doings for Saab in the car show circuit. At the North American International Auto Show in Detroit, Saab displayed their nearly-ready-for-prime-time 9-7X and the Insurance Institute for Highway Safety's crashed 9-3 (story on page 24). In a few days, at the Geneva International Motor Show, Saab will take the wraps off the 9-3 SportCombi (photo on page 37). Shortly thereafter comes the New York International Auto Show. Who can say what will appear there?**

*Seth D. Bengelsdorf, Editor and Publisher*

## Letters

### Love That Saab Shop

*Dennis Snelling sent this letter to us and asked that it be reprinted to show his gratitude.*

I wish to express my appreciation for the excellent service rendered by the staff of Woodworth Saab (Andover, MA). My wife and I were returning home to Maine from a visit to Rochester, NY, on December 28, 2004, when the serpentine belt pulley disintegrated without warning.

My 2000 Saab 9-5 had just been serviced 2,000 miles earlier at my dealer so it was quite a shock. I was traveling north on Route 495 at about 65 M.P.H. when the temperature shot up, the battery symbol displayed and the power steering was non-existent. With my four-way flashers blinking, I exited. Imagine my relief when my wife spotted the Saab dealer sign.

We were met by a pleasant young man in a jacket with the word "Valet" on the back. He assured me that Shawn would look after me. That's when I met Shawn Wise, the Saab service consultant who immediately took charge of the situation. The service technician even drew a diagram of the belt system. I was also impressed with your pleasant cashier.

In just under two hours we were on our way home in a nice clean car, courtesy of your free car wash. Mr. Kelley, I highly recommend your dealership for the caring attitude exhibited by all your employees.

Thanks again for turning a bad situation into a positive one. Please continue to keep up the good work.

Dennis Snelling  
Vassalboro, ME

### Love That Saab

*Len Schrader wrote this in response to a column in Automobile Magazine. We thought it was appropriate to reprint part of it here, as a way to foster discussion.*

I have been an exclusive Saab dealer, living, breathing and immersed in the brand for 33 years. If one were to be accurate in characterizing Saab buyers, it should be said that they can afford almost any car, know a good deal when they see one, and are confident and independent enough to buy a car that has substance as well as image.

The Saab car has always been a reflection of Swedish social, economic, and environmental standards that have driven Saab engineering innovations focused on finding a better way. The end result has produced cars that are fun to drive, safe, efficient, utilitarian, and extremely durable. All of these attributes make up the car's "Saabness."

# So Many... So Affordable... So Perfect, the new ones are getting jealous.



**LARGEST PRE-OWNED SAAB INVENTORY IN THE WORLD**  
GREAT SELECTION OF NEW AND CERTIFIED SAABS

Welcome to the  
state of independence



EXPERT SAAB SERVICE & PARTS - NEW & USED

# ROBERTI



# SAAB

385 Foxhall Avenue, Kingston, NY 12401

845-339-SAAB

[www.roberti.com](http://www.roberti.com)

Unfortunately, the automotive press tended to downplay these attributes and became perpetually fixated on the "key on the floor," and "quirky" became Saab's press identity. As a consequence, the press has continued to miss what every Saab owner has grown to appreciate: that Saabness and quirky are synonymous with better.

But the changing world market, low sales volume, and high production costs put Saab, as an independent company, in jeopardy. Additionally, there were many lost opportunities -- a frontdrive wagon in the 1980s, all-wheel drive, and an SUV several years ago.

GM's current strategy is an expeditious plan to lead Saab to the next generation of product. The current management team at Saab is the most energetic and aggressive I have seen in years. The 9-2X offers great promise for Saab to reach a market that we have not addressed for years. The new 9-7X will fill a void with a product that will be viewed as the best execution of all the GM variants. I know for a fact that Saab engineers are intricately involved in making these products to Swedish standards that have always been reflective in Saabs, an attribute that goes far beyond key placement.

Today, Saab offers the best product the company has ever produced. Product quality is exceptional and all the attributes that make a Saab a Saab are there, and are even better.

Len Schrader  
Denville, NJ

### Love My Saab

My 1999 Viggen has been somewhat

of a continuing project with several modifications - engine, transmission, suspension, etc. I have made dynamometer pulls after each major step, with some track time in the mix. This would probably make some good reading for the Viggen and 9-3 NG crowd. Several years ago I wrote for *Victory Lane Magazine* when I was running my two-liter Trans-Am car more.

John Smith, Jr.  
Knoxville, TN



*Editor's note:  
Absolutely! Even for those of us non-Viggen or 9-3 NG crowd. Write it up and send it in!*

**John's  
hopped-up  
Viggen.**

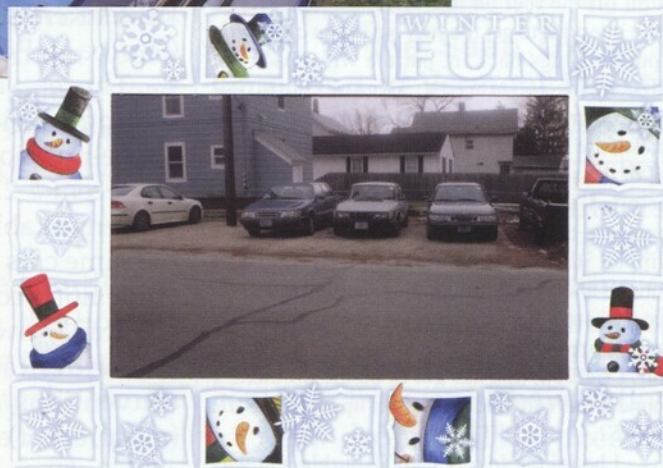

Submissions to Letters are always gratefully accepted! Make sure you include your name and address. Letters may be edited for content and length. Send them to:

Seth D. Bengelsdorf  
Editor  
NINES  
30 Puritan Drive  
Port Chester, NY 10573  
nineseditor@earthlink.net

We got the above holiday greeting card from Linnea Krajewski. It's not every day you get a card featuring the brood! See Linnea's article on page 36.



www.saabnet.com

Over 115 million pages of Saab info served and over 171,804 visitors each month.







Saab news and Saab images library  
Frequently asked questions and answers  
Chat online with Saab master Technicians and other enthusiasts  
Bulletin Boards  
99, Sonett, C900, NG900, 9000, 9-3, 9-5, Detailing and Performance  
as well as: 2003 SOC, NESA, SCNA, BASC and WASSAAB Boards  
Participate in monthly online polls  
Over 171,804 Saab visitors each month  
Enter monthly Saab raffles

Free saabnet.com web-based email  
Buying or selling a Saab? See it on saabnet.com classifieds  
Join the saabnet.com mailing list

saabnet.com - as featured in Consumer Reports' 2001 Used Car Buying Guide

## Love My Saab Friends

I was out playing in the snow we had just received (still coming down fairly heavy as I type). I was drifting around corners and such and I was having a blast with my friends, mainly in empty parking lots.

Anyway, I was driving normally down our main strip in our small city and I heard the notorious "PPOOOOFF" of an intercooler pipe blowing off. It stalls out completely, and I coast halfway into the Rite-Aid parking lot entrance.

I pop the hood and get out of the car with my flashlight in hand. I look over the IC pipe I always have issues with, and it looks fine. I then look over to the long pipe and notice it blew off of the turbo. I remove the pipe, position the clamp, and tighten it down. I get in my car, and I go to turn it over.

Nothing.

I returned to look under the hood and saw nothing wrong, except for the smell of fuel. A lot of fuel. Thankfully, my friends just happened to be driving by (Kyle, Tim, and my Pepere), and they asked what happened. They lent me a hand, and we took out the plugs, thinking it may have been flooded. Cylinder two was indeed flooded, so we took a lighter to the plug and burnt off the fuel on it. I then turned it over in little intervals to get the fuel out of the cylinders. I put the plugs back in, put the wires back on, and went to start it. Again, nothing.

Frustrated, I took off the distributor cap and made sure it was dry, breaking the ground right off of the side of the distributor in the process. I stripped the wire and screwed it back in, repairing that problem. The cap was dry, so I clipped it back on. I looked at the coil and noticed a loose wire. I put it back on firmly and tried to start it. Still nothing. I then noticed a small wire completely disconnected from the coil. I figured, this has got to be the problem. I connect the wire and go to start up my car. SHE LIVES!

I heard the lovely C900T burble and was so happy. I stood outside in the heavy snow on ice for 2 1/2 hours trying to figure this problem out, with about five friends. I thank them! Friends to thank: Ben -- for noticing the disconnected wires, Mutha (Todd) -- for helping me with the plugs and distributor, Steve -- for helping with the plugs and helping me push the car into the parking lot with his Explorer, Jimmy -- for being there. Thanks, guys! I really appreciate it! And thanks, Kyle and Timothy Crisman, my Pepere (Charlie St. Sauveur), for looking out for me! What are the odds that all of these people would come to my rescue without me calling them, and late at night in a snow storm?

Zach Wallace  
Clairmont, NH

Déjà vu? Well, yes, in a photographic sense and more, perhaps. I was looking through my collection of NINES magazines when the cover photo of #232 from November 1996 really caught my attention. Pictured is Larry Westergard with his SAAB 99 pickup, powered by a 16-valve turbo engine. This unusual Saab won second place in the Modified Class at the Concours. Fast-forward and readers of *Classic Motorsports*, the January 2005 issue will find a picture of the same car, also shown in a mountain setting!

Tim Winker took the NINES photo at the convention. The most recent photo appeared in an article for *Classic Motorsports*, written by William "Chip" Lamb, regarding the 2004 Convention held at Crystal Mountain, WA. The bright red Saab won two awards this time, the Walter Kern Award and the People's Choice Personality Award.

There are many other photographic similarities in the above-mentioned NINES issue and the recent # 271. The group photos are remarkably alike, and many of the same cars are shown, including, while not a complete car, the "Saab 48" trailer owned by John Collins. Coincidentally, these two conventions are the first and last (most recent) that my spouse Gayle and I have attended. If any conclusions can be drawn from the comparison of these two conventions, I would have to say the West Coast Saab owners were and are very active, especially with their classic, extraordinary and rare models.

Some more highlights from #232 that caught my attention were Tim Winker's articles about the Saab 900 Talladega Challenge. Saab at this time was doing a great job of showing the durability and

reliability of their cars by repeating, as far as was possible, the Long Run, or endurance test of the then new 9000, accomplished ten years previously. I'm reminded of this every time I walk out to the garage to take my 900 Talladega out. Gayle and I were able to take advantage of Saab's IDS program to pick up the car and participate in Saab's 50<sup>th</sup> Anniversary Jubilee, where we met Eric Johnson and Chuck Andrews for the first time. Eric had shipped his 1960 96 over to Sweden to take part in the Northern Lights Challenge tour in which we also participated. Sure enough, in #232 there are articles about IDS, the Jubilee and Eric's car, which he later sold to Saab cars USA. As you can see, NINES issue #232 contains many features dear to me, and I'm looking forward to more déjà vu!

## Saab Racing History

By Carlos Walmsley

I though you might enjoy this little piece of local Saab history that is really superb.

In the 1965 international Gran Premio of Argentina, the weeklong open road race on gravel, tarmac, mountains, plains and deserts, four little Saabs were on the starting grid, all private entries, with very little cash and few spares. In the starting line were, to mention just a few: Mini Cooper S, Alfa Romeo Giulia TI Super, Guilietta TI, 2600 Sprint, Volvo 544, Jaguar MKII, Ford Cortina Lotus, Renault 8 Gordini, Ford Mustang V8. There were 350 cars total.

The first leg was 900 kms, all night driving, flat out straights, and some mountain at the end, had a very strange finish. The first overall was an Alfa Romeo GTA with a special aluminum body and factory tuning; second overall was a Saab 96 driven by Roberto Fojo; behind our car came the rest of the crowd.

Keep in mind this is not rally driving with stages, this was 900 kms flat out, nonstop.

I think this is a unique Saab achievement and would love to hear of something similar in Saab history.

Fojo is today in a home suffering Parkinson's, any prayers or Saab wishes will be most welcomed by my local hero. You guys would have loved to have met him and heard his stories.

## Saab Technical Training Takes On New Look, New Locations

The last issue of NINES noted that the seventh annual New Jersey Saab Club Technical Training Session might well be the last one at the Wallingford Training Center as a result of changes to the training organization.

The last Saab class was indeed held in Wallingford in early December, at which point we relocated the cars and equipment to the GM Training Center in Tarrytown, NY. Similar moves took place in Chicago, Atlanta and Los Angeles, where GM centers were located reasonably close to the existing Saab training centers. In each case, one of the resident Saab instructors transferred over to the new facility. These moves are part of the ongoing integration of many of our dealer support functions into the GM organization and will allow us to take advantage of their resources and experience as new products like the 9-7X come along.

It was amazing how many public-spirited individuals were there at the last tech session. Almost everyone offered to help me move, and even store at no charge, all those pesky special tools, Tech IIs and several decades' worth of scrounged and scavenged parts we had rescued from the dumpster. The two

brandnew classic 900 gearboxes were particularly popular.

The Connecticut connection with training, and Saab in general, goes back to the early 1960s when the headquarters operation moved out of Hingham, MA, and into the 100 Waterfront Street address in New Haven that you can see in most of our early literature. When I joined the organization in 1968, the service school, parts warehouse, headquarters staff, competition department, two stroke rebuilding shop, and anything else you could think of were located in an old four-story building down near the docks. Once a month the Saab ship would tie up and we would grab some spare batteries, several cans of ether, dozens of fresh spark plugs and set off to help unload about 1,000 95s and 96s. It was a mixed bag of two strokes and V4s at that point.

You haven't lived until you have been down in the bottom hold of a ship during the dead of winter and the longshoremen have just fired up a few dozen stone-cold two strokes. Typically they would leave the chokes out and drive off with the column shifter where they would normally find first gear on their Chevy (second gear in a four-speed Saab). Equal parts of stoker exhaust and clutch smoke make for a heady and darn near lethal mix. But that's another story.

For the first time in more than thirty years I will not be doing training on a full-time basis. Instead, I will be traveling around the Northeast helping dealers with problem cars. Whenever possible, I plan on arranging it so these cars are in areas with high concentrations of two stroke owners, tractor junk yards and



**John, at the Saab Owner's Gathering in Vermont in July, 2004.** Photo by Seth D. Bengelsdorf.

post-and-beam barn builders. Highest priority, of course, will be wherever there is a gathering of the Saab faithful, like the tech sessions. The event will certainly continue, but we will have to find a new home. The freshly refurbished barn on the Eig estate sounds like a good candidate for next November. My own yard is still much too disreputable, even though the 700-pound pet pig is no longer in residence. That, also, is another story!

*John's current title is regional technical representative. He says, "The Brits have a much better name, 'flying spanner.' We trundle around to dealerships hoping to sort out problem cars."*

## Changing The Cabin Fan On A Classic 900

With one too many digits the classic 900 is not considered a “vintage” Saab by the vintage Saab folks, but let me tell you, these cars are getting old. Still, with three C900s in the family and with maybe one major repair (the equivalent of one new car payment) per car per year, these may be about the most reliable Saabs ever. You can see these cars are dirt cheap to own and run. Hammare\*, our 1984 900T in “Special Black”, the last of the eight valve 900 Turbos, soldiers happily along at 299,000 miles with just the occasional weird old car failure, the latest being the topic of this article.

Hammare’s heater fan began making a racket a few months back, but it wasn’t until the first northeast postelection cold snap that I felt motivated to change the thing. The cabin fan on the 900 is a tad difficult to reach but pretty easy to see: you just pull the passenger side dash-top speaker out and there it is! But you can’t take it out from there.

Physically and technically it’s not a tough job, but it is a little tedious, because you have to remove the instrument panel, and the main upper padded dashboard, to expose the thing. Nothing special needed, just a selection of Phillips and Torx tools and the means to remove the stereo from the top slot (if you have your radio there).

Before starting this job you want to have a good replacement fan. There are a couple of benefits to sourcing a used fan for this job. First, it’s cheaper, and, second, you get to practice some more when the replacement fails. Every time gets easier. Having once gotten a defective fan from a junkyard, the very first thing to do with a used fan

is to remove the speaker grill, pull off the wires, and hook them up to test the replacement unit. Smooth, quiet, breezy? Nice. OK, on with the job.

1. Remove the radio.
2. Optional: If you want to make this job really easy and give yourself lots of room to work, pull the steering wheel. Make sure the steering wheel is pointed straight ahead. Pry out the steering wheel center emblem or pad, undo the

22mm bolt and off it comes (airbag people: you’re on your own).

3. Loosen the center instrument panel section (epc: instrument plate) by unscrewing the four funky Phillips head screws arrayed along the bottom of the instrument panel. Pull them all the way out, and mark them. If you have a center console, the fourth, right-most screw is hidden up inside the ashtray opening.

4. Gently pull the instrument plate away from the main padded dash panel enough to get your hand

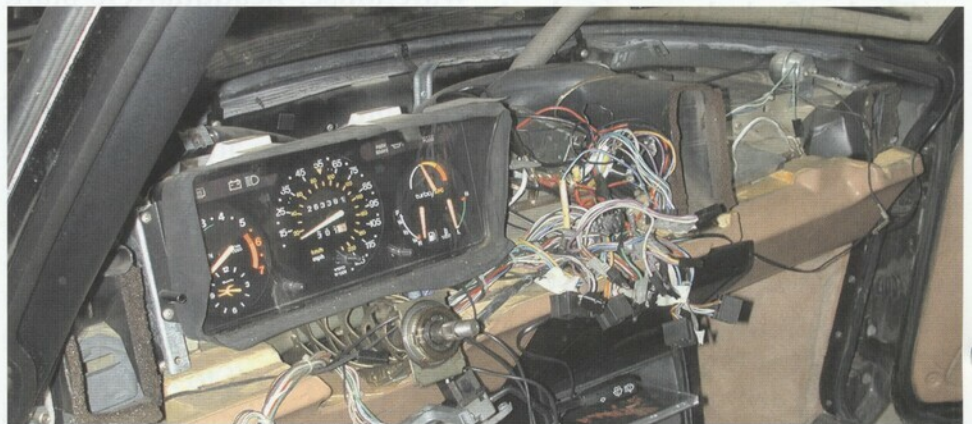

**Here’s the dash in the midst of the process. Not a pretty sight.** *Photos by the author.*



**Much better.**



behind, then push out the switches (headlight, fog, electric mirror, flasher, A/C, etc.) from behind. Unplug each switch and set them off to one side. For the defroster/flasher/AC/recirculate switches, you might want to label the plugs for easier reassembly.

5. Unplug the wires to the cigarette lighter and fan speed control.

6. Pull out the instrument lights.

7. Pull the five electrical connectors off the air distribution

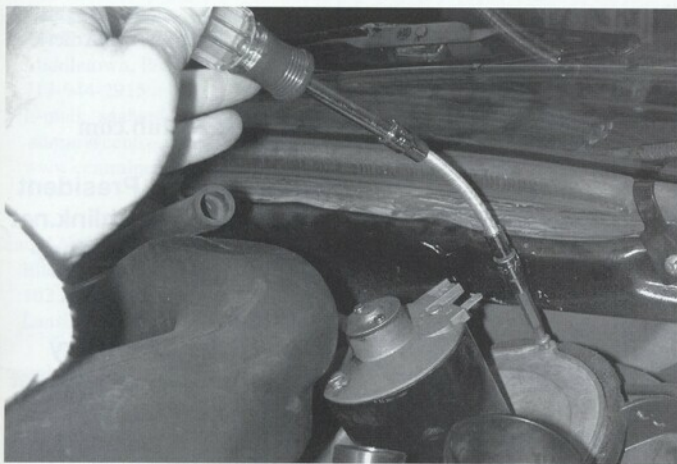

**The trick to accessing some of the difficult screws? Proper tools.**

switch. Unless you want to learn to read wiring diagrams with Swedish color codes (hint: "bk" is not black and "sv" is not silver), these five wires are good ones to mark (I put tape on, marking the top as "T," then 2, 3, 4, 5).

8. Unhook the plenum from the back of the vacuum distributor.

If we didn't forget too much, the center panel assembly will just come out and can be placed on the roof, or the back seat. After that, removing the main dash is pretty simple:

Remove both dash-top speakers, then remove one screw from each speaker opening. You'll see them.

Then remove the two screws underneath the glove compartment door and wiggle the whole padded dash assembly out.

You've done it! Step back and look at the result. Scary looking, but you now have a clear shot at the cabin fan unit. Pull off the wires and the ventilation hose from the fan motor, use a stubby screwdriver or a flex driver to remove the three mounting screws, then the motor lifts right out. Installation, as they say, is the reverse of removal, but here are a few things to think about:

**A.** If your radio and switch wiring are spaghetti like, take a little time to tidy it all up with plastic ties to ease reassembly.

**B.** Take a few minutes with the tricky job of reattaching the side defroster hoses. Cuss.

**C.** Reattach all the wires to the appropriate spots on the climate controls. Work almost blind. Cuss some more.

**D.** After you've wiggled the instrument panel into position, pull it back out just a little so you can reattach the heater control rod.

**E.** See the little light bulbs for the lighter and climate controls? The one with the brown and brown striped wire is for the fasten seat belt light. This was the first time I got that one back in the wrong spot.

**F.** Take care to get the four long different-length instrument-panel screws back in the right positions.

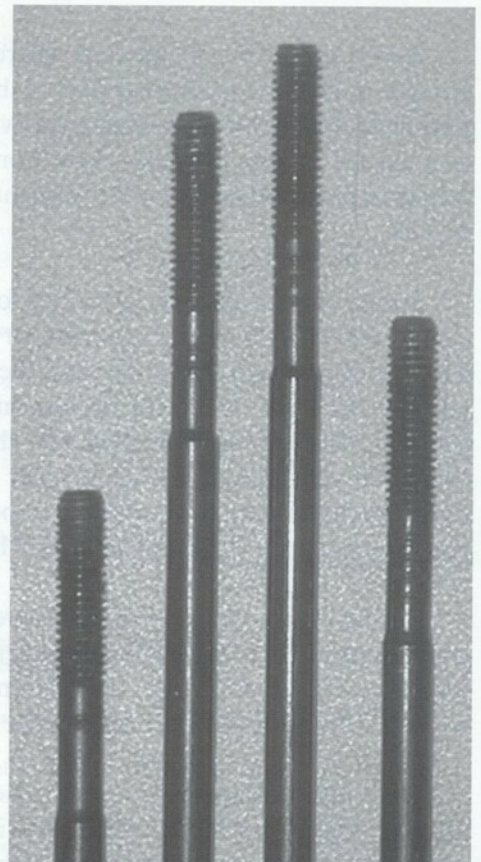

**Screws are shown in order. Remember to mark them with 1, 2, 3, or 4 on their shafts.**

**G.** Replacing the steering wheel: Your high mileage car may benefit from a drop or three of oil down the steering shaft and a light application of all-purpose grease on the fan ring.

Step back and admire your handiwork. I took my sweet time with coffee and telephone breaks and did this job in five hours start to finish, but it could have been done quite a bit faster. So now Hammare has robust heat again and the total cost to me was just a few hours of labor. Another reason to love these old cars.

\*Hammare: Swedish for hammer, a fitting replacement for the late, lamented SPG Mjollnir, named for Thor's mythical hammer.

Here's hoping that by the time you read this, spring has either arrived, or is about to, in your part of the world. For those of us who have to slog through winter, the warmer temperature gives us a chance to get our Saabs clean from all the road grime and waxed to protect them from the elements, plus help it look great as well.

Spring also means more activities for you and for local clubs. Check out NINES, [saabclub.com](http://saabclub.com), or The Saab Network for postings of club activities and join in the fun. No local club where you are? Start one! Just come up with an idea, like a local drive, a gathering or event of some kind, and then start contacting other owners in your area. You can ask your local Saab dealer or independent shop to hand out flyers, put flyers under windshield wipers of Saabs you see in parking lots in your town, post a message on [saabnet.com](http://saabnet.com) or in NINES.

The point is to get involved and have FUN! And one of the most fun events you can ever hope to attend is our annual Saab convention, this year in beautiful Vermont in mid-August. Details are in NINES, on Saabnet and also on our convention Web site, [www.saabconvention.org](http://www.saabconvention.org). I hope to see you there!

One important piece of club business will be held during the convention: the annual meeting. The annual report of club activities, finances and so on is presented to the members, and any issues that need to be voted on by the members is discussed here. One big issue will be elections for several board positions. Start thinking now if you'd like to run for a spot, as the election process starts soon. Details should be in the next issue of NINES.

Finally, speaking of the board, President Garry Grimes and I have been serving "overtime" since last August, when no volunteers stepped up to take our places on the board. We agreed to serve another six months and try to find replacements. As of this writing, we're still searching. Let's not allow this to happen again for the upcoming election. If it does, it could mean the death of our young club.

Which makes my next statement even harder to make: I am resigning my position as vice president effective February 28. More than two years ago, I stepped up and agreed to serve in this position. Garry and the other board members got this club moving in a positive direction, and they have done a good job of keeping it going, despite some bumps along the way. But, as stated before, I agreed to serve another six months and that time is up.

My hope is that at least one member out there will read this and decide he or she wants to keep this club growing, and will contact the board to serve now or when election time comes in August. It does involve some work, but it's not that much and it can be very rewarding to see the club continue to evolve into something great.

Happy Saabing,

Dan Orzano  
Vice President (ret.)

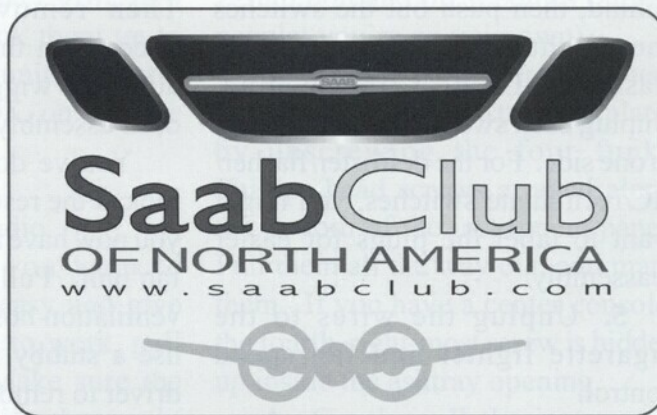

The Saab Club of North America, Inc.

[www.saabclub.com](http://www.saabclub.com)

**Garry Grimes, President**  
[eggrimes@earthlink.net](mailto:eggrimes@earthlink.net)  
**Dan Orzano, Vice President**

[dorzano@cs.com](mailto:dorzano@cs.com)

**Mike Heyse, Secretary**  
[michael.heyse@verizon.net](mailto:michael.heyse@verizon.net)  
**Marc Fails, Treasurer**  
[neuswede@comcast.net](mailto:neuswede@comcast.net)

**Jon Hochstetter, Membership Chairman**  
[jhox@wi.net](mailto:jhox@wi.net)

**Bruce Harbison, Concours Chairman**  
[bharbison@comcast.net](mailto:bharbison@comcast.net)

**Christine Krueger**  
[ck17@bellsouth.net](mailto:ck17@bellsouth.net)

**Linnea Krajewski**  
[yeehhaahh@aol.com](mailto:yeehhaahh@aol.com)

**Darren Aklanis**  
[daklan89@yahoo.com](mailto:daklan89@yahoo.com)

The Saab Owners' Convention  
Permanent Web Site  
[www.saabconvention.org](http://www.saabconvention.org)

NINES, The Saab Club Magazine  
30 Puritan Drive  
Port Chester, NY 10573  
914-937-6075

[nines@earthlink.net](mailto:nines@earthlink.net)  
Subscribe or renew online at  
[www.saabnet.com/forms/nines.html](http://www.saabnet.com/forms/nines.html)

# North American Saab Clubs and Contacts

## Appalachian Saab Club

Ken Edwards  
296 Brethren Church Dr.  
Jonesboro, TN 37659  
423-753-3153

## Bay Area Saab Club

Clifford Quan  
4207 Skymond Dr.  
Belmont, CA 94002  
650-225-7075  
E-mail: cliff@gene.com  
www.bayareasaabclub.com

## Carolinas Saab Register

Jason Henske  
2830 16th St. NE Apt. #99  
Hickory, NC 28601  
704-256-9211  
E-mail: NCSaabreg@AOL.com

## Central Penn Saab Club

George Basehore  
477 E. Main St.  
Middletown, PA 17057  
717-944-2915  
E-mail: saaber41@epix.net  
admin@centralpennaab.com  
www.centralpennaab.com

## Central New York Saab Club

Ellen Kolynich  
102 Armstrong Rd.  
Lansing, NY 14882

## Central States Saab Club

Kyle J. Poppert  
4015 N St.  
Lincoln, NE 68510  
402-488-5730  
E-mail: saabarts@aol.com

## Florida Panhandle Saab Club

Mike "SaabDude" Szostkiewicz  
2016 Pritchard St.  
Panama City, FL 32405-1446  
Phone/fax: 850-785-7372  
E-mail: SaabDude@bellsouth.net  
or SaabDude@mail.saabnet.com

## Great Lakes Saab Club

Jim Laman  
617 Beechwood  
Holland, MI 49423  
616-335-5215  
E-mail: lamanjim@juno.com

## Gulf Coast Saab Club

Ron Hernandez  
2422 Killdeer St.  
New Orleans, LA 70122-4316  
504-283-0822  
E-mail: rthrnandz@AOL.com

## Milwaukee Saab Club

Andy Saksa  
2480 Eastwood Lane  
Brookfield, WI 53005  
262-785-1550

## Minnesota Saab Club

Dean Nelson  
1420 15 Terrace NW  
New Brighton, MN 55112  
612-636-3771

## New England Saab Association

John delRosario  
76 High St.  
Gloucester, MA 01930  
E-mail: info@nesaab.org

## New York Saab Owners' Club

Stephen Pivonka  
9 Timothy Dr.  
Schuylerville, NY 12871  
E-mail: spivonka@nysoc.com  
www.nysoc.com

## North Coast Saab Club

Kevin O'Malley  
5451 Broadview Rd. (Rear)  
Parma, Ohio 44134  
E-mail: fotoomal@sbcglobal.net

## Northwest Saab Owners (Washington, Oregon, British Columbia)

Jon Kjaerulff  
PO Box 1685  
Gig Harbor, WA 98335  
206-255-8398  
www.nwsoc.org  
E-mail: president@nwsoc.org

## Rocky Mountain Saab Club of Colorado

Tom Nelson, President  
353 Ruby Forest Trail  
Evergreen, CO 80439  
303-526-9138  
www.rockymtnsaabclub.com  
E-mail: tom10@wispertel.net

## Saab Club National Capital Area

Alan Crosby  
11886 Purcell Rd.  
Lovettsville, VA 20180  
540-882-4008  
E-mail: alancrosby@aol.com

## Saab Club of Central Ohio

Dan Orzano  
300 Sheldon Ave.  
Columbus, OH 43207  
614-444-4885  
E-mail: dorzano@cs.com

## Saab Club of Georgia

Chris McPherson  
915 Franklin Goldmine Rd.  
Cumming, GA 30040  
770-844-5961  
www.accessatlanta.com/  
community/groups/saabclub/

## Saab Club of Iowa

Marty Adams  
PO Box 99  
Stacyville, IA 50476  
515-737-2239  
E-mail: info@meyersaab.com

## Saab Club of NE Pennsylvania

Ron Augelli  
1723 Clearview St.  
Scranton, PA 18508  
717-969-9863

## Saab Club of Texas

Clay McNeely  
Rt 4 Box 54 Aa  
Hereford, TX 79045  
806-364-6094  
E-mail: SCofTX@juno.com

## Saab Club of Northeast PA

Ron Augelli  
1732 Clearview Street  
Scranton, PA 18508  
888-411-2205  
570-969-9863  
E-mail: ronaug1@yahoo.com

## Saab Club of Tampa Bay

Bobby Keen, president  
Alan Fein, vice president  
www.saabcluboftampbaya.com

## Saab Club of Western Canada

Kenneth Kuo  
Vancouver, British Columbia  
Canada  
604-730-8425  
E-mail: saabken@yahoo.ca  
http://ca.groups.yahoo.com/  
group/scwc\_list

## San Diego Saab Owners' Group

Chris Rogers  
10559 Lansford Lane  
San Diego, CA 92126  
858-530-0019  
E-mail: chris@sandiegosaab.com  
www.sandiegosaab.com

## Southern California Saab Club

Steven Hayes  
8573 1/2 Walker St.  
Cypress, CA 90630  
714-826-8407  
E-mail:  
SoCalSaabClub@yahoo.com

## Saab Owners of Canada, Inc.

Neil Palmer  
171 Abraham St.  
Cambridge ON N3H 1H4  
Canada  
416-565-1682  
E-mail:  
president@saabclubofcanada.ca  
www.SaabClubOfCanada.ca

## The Saab Club de Montréal

Peter McLoughlin  
20 Roundtree Crescent  
Rigaud, Québec, J0P 1P0  
Canada  
450-451-5165  
E-mail: pm3000@ca.inter.net

## Tristate Saab Club (OH, KY, IN)

Phil Lacefield Jr.  
3907 Grand Ave.  
Middletown, OH 45044  
513-423-9299  
E-mail: phil@lacefield.com

## Washington DC Saab Club

Michael Heyse  
2314 Hildarose Dr.  
Silver Spring, MD 20902  
301-593-0988  
E-mail: michael.heyse@verizon.net  
www.wassaab.com/

## Utah Saab Club

Chris Cox  
PO Box 526105  
Salt Lake City, UT 84152-6105

## Vintage Saab Club of North America

PO Box 4362  
Manchester, NH 03108-4362  
E-mail: sonett1@frontiernet.net

## Western Pennsylvania Saab Club

Andy Bittenbinder  
9433 Katherine Dr.  
Allison Park, PA 15101  
412-366-6165  
www.westernpasaab.com

## ONLINE CLUBS

### The Saab Network

www.saabnet.com

### Turbo!

Send an e-mail request to  
turbo-request@secret-  
secret.com.  
Place the word "subscribe" in the  
subject line and the body of the post.

### VSAAB, The Vintage Saab Mailing List

www.vsaab.com

Know of any additions?  
Subtractions? Changes?  
Corrections?  
Let us know! Send your  
information to:  
Editor  
NINES  
30 Puritan Drive  
Port Chester, NY 10573  
ATTN: Clubs and Contacts  
nineseditor@earthlink.net

# Saab Club Discounts

The dealers listed below honor a generous courtesy discount to all SCNA members on most Saab parts, service and accessories. This discount is off the regular everyday prices. Here's reason enough to be a member! Please present your membership card before service and remember to say "Thanks!" for their continued support of the Saab Club of North America.

**Armando's Saab** 10% Discount on Parts & Service  
4340 Boardman-Canfield Road  
Canfield, OH 44406  
Phone: 330-533-1944; Fax: 330-533-0091  
Web site: www.armandosauto.com

**Arroway Saab** 10% Discount on Parts & Service  
140 Bedford Road, Katonah, NY 10536  
Phone: 914-232-7733; Fax: 914-232-418  
Web site: www.arrowwayauto.com

**Autohaus Saab of Pompano** 15% Discount on Parts & Service  
500 N. Federal Highway, Pompano Beach, FL 33062  
Phone: 954-784-0234; Fax: 954-783-6202

**Brewer's Saab** 10% Discount on Parts & Service  
13815 Maugansville Road, Maugansville, MD 21767  
Phone: 301-373-7373; Fax: 301-739-8711  
Web site: www.brewers-saab.com

**Brown Saab** 10% Discount on Parts & Service  
1357 Richmond Road, Charlottesville, VA 22911  
Phone: 434-817-3380; Fax: 434-817-6260  
Web site: chlsaab.brownsaar.com

**Crawford Saab of El Paso** 10% Discount on Parts & Service  
6800 Montana Avenue, El Paso, TX 79925  
Phone: 915-778-7781; Fax: 915-778-9468  
Web site: www.crawfordautoplaza.com

**Dave Towell Saab** 10% Discount on Parts & Service  
111 W. Market St., Akron, OH 44303  
Phone: 800-621-0674  
Web site: www.towellsaab.com

**David O'Neal Saab** 10% Discount on Parts & Service  
5500 Capital Boulevard, Raleigh, NC 27616  
Phone: 919-872-5500; Fax: 919-878-0343  
Web site: www.davidoneal.com

**Dirito Bros.** Walnut Creek 10% Discount on Parts & Service  
1890 N. Main Street, Walnut Creek, CA 94596  
Phone: 925-934-8224; Fax: 925-934-0136  
Web site: www.dirito.com

**Downtown Saab** 10% Discount on Parts & Service  
4137 Broadway Oakland, CA 94611  
Phone: 510-547-4625; Fax: 510-653-3181  
Web site: www.downtownsaab.com

**Garden City Saab** 10% Discount on Parts & Service  
301 North Franklin Street, Hempstead, NY 11550  
Phone: 516-483-7200; Fax: 516-483-7611  
Web Site: saab.turbotownusa.com

**Hunt Valley Saab** 10% Discount on Parts & Service  
11212 York Road, Hunt Valley, MD 21030  
Phone: 410-527-9595; Fax: 410-527-9270  
Web Site: www.huntvalleysaab.com

**International Motors of Dulles** 10% Discount on Service  
21601 Ashgrove Court, Dulles, VA 20166  
Phone: 703-948-7222; Fax: 571-434-2849  
Web site: www.internationalsaab.com

**Iowa City Saab** 10% Discount on Parts & Service  
4165 Naples Avenue S.W. Suite 3, Iowa City, IA 52240  
Phone: 319-337-7222; Fax: 319-337-7233  
Web site: www.meyersaab.com

**Jaremko Saab** 10% Discount on Parts & Service  
6901 E. Sprague Street, Spokane, WA 99212  
Phone: 800-659-8934  
Web site: www.jaremkosaab.com

**Jessup Auto Plaza** 15% Discount on Parts & Service (Member discount not available for mail-order parts, sorry)  
68-111 Highway 111, Cathedral City, CA 92234  
Phone: 760-328-2571; Fax: 760-321-4670  
Web site: www.jessupautoplaza.com

**J.M.K. Saab Inc.** 10% Discount on Parts & Service  
345 Route 22 East, Springfield, NJ 07081  
Phone: 973-379-7744; Fax: 973-379-3896  
Web site: www.jmksaab.com

**Jim Ellis Saab of Marietta** 10% Discount on Parts & Service  
1141 Cobb Parkway, Marietta, GA 30062  
Phone: 770-590-4450; Fax: 770-590-4466  
Web site: www.jimellis.com

**Just Saab** 10% Discount on Parts & Service  
15% Discount on Mail-order Parts at all 3 Stores  
5449 Dixie Highway, Fairfield, OH 45014  
Phone: 513-829-4700; Fax: 513-829-1441  
6950 Loop Road, Centerville, OH 45459  
Phone: 937-435-7222; Fax: 937-432-9267  
6323 Madison Road, Cincinnati, OH 45227  
Phone: 513-527-4300; Fax: 513-527-4170  
Web site: www.justsaab.com

**Kelly Saab** 15% Discount on Parts & Service  
900 Riverfront Parkway, Chattanooga, TN 37402  
Phone: 423-267-1104; Fax: 423-265-6938  
Web site: www.kellycars.com

**Ken Garff Saab** 10% Discount on Parts & Service  
198 East 500 South, Salt Lake City, UT 84111  
Phone: 866-293-3333; Fax: 801-257-3462  
Web site: www.kengarffsaab.com

**Kunkle Motors** 10% Discount on Parts  
RR 1, P.O. Box 386, Dallas, PA 18612  
Phone: 570-675-1546; Fax: 570-675-7914  
Web site: www.kunklemotors.com

**Meyer Garage** 10% Discount on Parts & Service  
2687 480th Street, McIntire, IA 50455  
Phone: 641-737-2239; Fax: 641-737-2601  
Web site: www.meyersaab.com

**Mitchell Saab** 10% Discount on Parts & Service  
384 Hopmeadow Street, P.O. Box 127, Simsbury, CT 06070  
Phone: 860-408-6065; Fax: 860-408-6083  
Web site: www.mitchellsaab.com

**Morrie's Saab** 10% Discount on Parts  
12550 Wayzata Boulevard, Minnetonka, MN 55305  
Phone: 952-544-0096; Fax: 952-544-2411  
Web site: www.morries.com

**P J's Auto Village** 10% Discount on Parts & Service  
2073 Williston Road, P.O. Box 2031, South Burlington, VT 05403  
Phone: 802-862-0875; Fax: 802-658-0025  
Web site: www.pjsautovillage.com

**Reinertsen Motors Inc.** 10% Discount on Parts & Service  
295 Route 53, Denville, NJ 07834  
Phone: 973-627-0616; Fax: 973-627-3561  
Web site: www.rmisaab.com

**Roberti Saab** 20% Discount on Parts & Accessories  
385 Foxhall Avenue, Kingston, NY 12401  
Phone: 845-339-7222; Fax: 845-338-1886  
Web site: www.roberti.com

**Saab of Memphis** 20% Discount on Parts & Accessories  
2177 Covington Pike, Memphis, TN 38128  
Phone: 901-373-7373; Fax: 901-372-7387  
Web site: www.saabofmemphis.com

**Saab Santa Fe** 10% Discount on Parts & Service  
2586 Camino Entrada, Santa Fe, NM 87507  
Phone: 505-984-8888; Fax: 505-471-6191  
Web site: saabsantafe.com

**Scott Saab** 10% Discount on Parts & Service  
3333 Lehigh Street, Emmaus, PA 18049  
Phone: 800-829-1877; Fax: 610-965-6905  
Web site: www.scottcars.com

**Swedish Automotive & Beyond, Inc.** 10% Discount on Parts & Service  
5321 Country Road, 154 Space C, Glenwood Springs, CO 81601  
Phone: 970-384-0249; Fax: 970-384-0352

**The Dorschel Saab Country** 10% Discount on Parts  
3817 West Henrietta Road, Rochester, NY 14623  
Phone: 585-334-9440; Fax: 585-359-3761  
Web site: www.dorschelautomotive.com

**Wausau Imports, Inc.** 10% Discount on Parts & Service  
2700 Sherman Street, P.O. Box 2107, Wausau, WI 54401  
Phone: 715-842-5636; Fax: 715-848-3204  
Web Site: www.wausauimports.com

**Zee Saab** 10% Discount on Parts & Service  
750 Bridgeport Avenue, Milford, CT 06460  
Phone: 203-878-4661; Fax: 203-882-5275  
Service Center: 314 Indian River Road, Orange, CT 06477  
Phone: 203-795-8324  
Web site: www.zeeauto.com

## Saabtoberfest 2004

For the past three years, Saab enthusiasts of all stripes from up and down the East Coast flocked to Dan Haddle's Eurotech Auto Repair shop in Wilkes-Barre PA. They are all driven by the desire to meet many others of like interest and the intense desire to seek out that one elusive thing, "the perfect fall drive." That drive is Saabtoberfest! This unique Saab-only event has been a rather stealthy happening since 1997. This year's route consisted of two 65-mile legs that traveled over some of Pennsylvania's most picturesque twisty, mountainous and deserted roads.

This year was the 1<sup>st</sup> time that a preregistration was available, thanks to the great efforts of Rob Ricardelli of Middletown, NY! Rob has also developed the [saabtoberfest.com](http://saabtoberfest.com) site, which will be the place to visit to read about both past events and upcoming ones as well.

This year's total registration saw 56 cars! This potentially hectic task of registering cars on the morning



**Some of the attendees lined up in anticipation of the start of Saabtoberfest 2004.** Photo by the author.

of the event went off with incredible success thanks to the help of Mike and Ginny Shaw of Queensbury, NY. The person traveling the farthest was Linnea "I love to drive" Krajewski, with a one-way distance of 406 miles.

During those busy morning hours the faithful were treated to coffee and doughnuts, compliments of Dan Haddle. A number of other

complimentary items from the various sponsors of the event were given to the registrants while they milled about and did a little "Saabtalk."

After the obligatory drivers meeting with instructions ("This is not a race! This is a parade!") and the command to "light 'em up," what appeared to be legions of Saabs began to assemble on both sides of the street. At least four very fine vintage Sonetts assembled along with the complete array of models. The nearly 60 cars separated into two more manageable groups. Once free of the city's confinement, it was time to let them run. The motoring adventure began with a heart-pounding climb up Giant's Despair, famed for its annual -- and the oldest -- hill climb in America. Amidst the turbo whine you could hear "this is what I came for." As we began to stretch out, the ride became a true adventure. We drove on through the forests scattering flocks of turkeys, herds of deer and an occasional black bear. The flaming foliage, the peaceful scenery, the wildlife, the

fantastically challenging drive put a grin on many faces.

We arrived in the quaint town of Weatherly, PA, where there are no gas stations in town! We paused for a time at the Eurana Park, where we gathered together for lunch and commiserated on the ride behind us and wondered about the road ahead. During our lunch stop, prizes were given to every single person in

attendance. Everyone went away with something pretty darn nice.

After we all recovered from our exuberant beginning, we rallied together and headed out. Up the famed mountain we went (the site of the annual Weatherly Hillclimb), engines screaming as they approached redline, and then we were off into the country side again. As we passed by a farm, I saw a father standing with his son. I was sure knew I heard him say, "You know that it's October my boy; the Saabs are running." We meandered back into more civilized lands for a time, then headed out into the beautiful Conyngham Valley as the day began to wind down. We made a final five mile assault on one of the steepest mountain roads with more switchbacks than one may have ever seen here on the East Coast! Finally, we reached our finish line at Castiglione's (the Castle of the Lion), a wonderful family-style Italian restaurant, noted for its hospitality. It was here before we had dinner that we gave away our grand prize, a set of four Nokian snow tires, graciously donated by Dan Haddle and Jack Williams Tire.

Unfortunately, the first five people whose names were drawn were not present, having left prior to the finish. Therefore, the winner of the Nokian Tires was Matt White of Hockessin, Delaware. After the award we settled in for an excellent dinner and reflected on what a wonderful day it had been. We swapped stories. Some stayed late into the night. We had all come away with some great memories and some new friends. We all fully intended to return next October for this great fall outing. Check out the photos and comments about this year's event as well as previous Saabtoberfests at [saabtoberfest.com](http://saabtoberfest.com). Maybe you'll be there next year? I know I'll be there!

# The Aero Academy



One of the perks of buying a new 9-5 Aero is that included in the price is an invitation to attend the Aero Academy (AA). The AA is a two-day performance oriented driving school sponsored by Saab Cars USA. After purchasing my 9-5 Aero SportWagon in July, I was eager to attend the Academy, especially after seeing the program *Go! Saab Aero Academy* on the high-definition channel, INHD. This 25-minute program provided an excellent overview of the entire class.

Since I was paranoid that Saab would cancel the program after the corporate move to Detroit, I asked my salesman, Mike, to expedite my AA certificate. I received my certificate about 10 days after taking delivery of my Aero. Of the half dozen or so dates that the AA was being held on, I chose to attend the October 9<sup>th</sup> and 10<sup>th</sup> session. The AA is held at Road Atlanta, located in Braselton, which is about fifty miles north east of Atlanta. Included in the envelope with the certificate was an overview of the class schedule, directions to Road Atlanta, and a list of accommodations. I booked a room at the Holiday Inn express about five miles from Road Atlanta for the 8<sup>th</sup> and 9<sup>th</sup> and reserved a rental car. I flew into Atlanta from San Diego on the 8<sup>th</sup>. As it turns out, Mike managed to persuade Saab to allow him to attend the Aero Academy, so we coordinated our flight plans and shared the rental car. One piece of information that is not contained in the mailing from Saab is the fact that traffic heading northeast out of Atlanta on a Friday

afternoon is a bear. It took us about three hours to travel the fifty miles from the Atlanta airport (Hartsfield) to the Holiday Inn.

Our first evening, Mike and I met up with a couple of folks we knew through The Saab Network at Paddy's Pub on the Château Élan grounds. The Château Élan is located across the street from the Holiday Inn and is where Saab hosts a dinner for AA participants after the first day of class. One of the people we met had attended the AA the prior year and was now an observer of the class while his wife participated. He gave us a quick rundown of the class, we talked a lot of Saab, and we downed a few Guinness beers.

Here was the schedule for the two days of class.

## Day One

8:00 – 9:30 Registration/  
Classroom – Vehicle  
Dynamics  
9:30 – 12:30 Skid pad,  
Braking, Baseline Autocross  
12:30 – 1:15 Lunch  
1:15 – 1:45 Classroom –  
Lane Change, Finesse Course  
(Salad Bowl)  
1:45 – 4: 45 Square  
pad, Lane Change,  
Finesse Course  
(Salad Bowl)  
6:30 – 10:00 Wine  
and Dinner at the  
Château Élan  
Winery

## Day Two

8:30 – 9:30  
Classroom – Safety  
9:30 – 12:30 Slalom,  
Wet Autocross

12:00 – 12:45 Lunch  
12:45 – 1:15 Classroom –  
Line  
1:15 – 3:30 Autocross  
Course – Wet & Dry  
3:30 – 4:30 Autocross  
Competition

The classroom for the AA is in a building located at Road Atlanta. The hands-on driving portions of the class, which makes up about 80 percent of the AA time, are held in three different areas of the infield at Road Atlanta. The registration process consisted of presenting my AA certificate and signing a liability waiver. I was glad I had taken advantage of the continental breakfast at the hotel, as only coffee and water was provided.

The classroom had three rows of tables arranged in front of a white board and a screen was set up to show course material slides. The first morning class opened with the lead instructor, Cass Whitehead, introducing the half-dozen or so other instructors. Cass then asked us to introduce ourselves and include how many Saabs we each have owned. Our class of eighteen attendees ended up with more than 55 Saabs! After



Photos by the author.

the introductions, Cass eased us into the concepts of vehicle dynamics. I have always enjoyed driving my Saab but never really thought too much about the fundamental importance of vehicle balance and how balance and weight distribution is affected by braking, accelerating, and turning. I know the basics, but I have never attended any type of performance driving school. This academic perspective of how the gas, brake, and steering all have an effect on each other was enlightening. Cass used what I understand now to be the standard friction circle to graphically illustrate how the use of your feet on the accelerator and brakes, and your hands on the steering wheel, manipulate the balance of the car and the available traction at each tire.

Cass emphasized the fact that the only part of the car that is in contact with the tarmac is a relatively small area on each tire. As weight shifts front to back and side to side, the amount of weight and traction available from each tire also varies. Pretending that there is a string tied to the bottom of the steering wheel and the go/stop peddles was another device Cass employed to try to get us thinking about how our feet and hands effect the distribution of total traction. As you turn the wheel increasingly to the left or right, your feet must lift off the pedals at the same time, since you are now using some traction to turn and losing some for braking or accelerating. He described what 'understeer' and 'oversteer' are and how to handle each of these conditions when they happen on the road. Proper seating adjustment and hand position on the steering wheel were also covered. The entire purpose of this morning

classroom session was to arm us with a little knowledge to take into the morning driving exercises. Cass also encouraged us to push our envelope of comfort a little, which he assured us would result in our amazement of how competent the Aero is as a sports oriented vehicle.

At the end of the morning classroom session, the instructors broke us up into three groups of six. The group I ended up with included Mike and most of the Saab Network folks in attendance. Each group was assigned two instructors, and then we piled into a fleet of AA cars. The instructors led each of their groups to one of three different driving exercises: baseline autocross, braking, and skid pad. All of the driving exercises are held in the Road

person took turns at driving about a dozen laps around the approximately three-eighths mile auto cross course, solo. While we each drove, Cass timed us, resulting in a baseline measurement of our driving skills in the form of a best lap time. After each of my group members had a chance to get timed in the autocross, we all got back in the Aeros and followed the instructors to the next exercise, panic braking.

The panic braking exercise had us going full throttle down a straightaway towards a lane of safety cones that curved. When a red light illuminated we had to react as quickly as possible and apply full brake, feeling the ABS thumping the brake pedal, all the while negotiating the curve without knocking any



Atlanta infield. We were especially lucky this weekend because it was an open track weekend at Road Atlanta, which meant that while we were not actively participating in a driving exercise we could ogle at the cars doing laps around us. My group went to autocross first. Here, each

cones over. This took a little more skill than it sounds like would be required. Besides being a lot of fun, this provided us with a great opportunity to feel what it's like to be panic braking with the ABS engaged. After each run, the instructor critiques the driver's

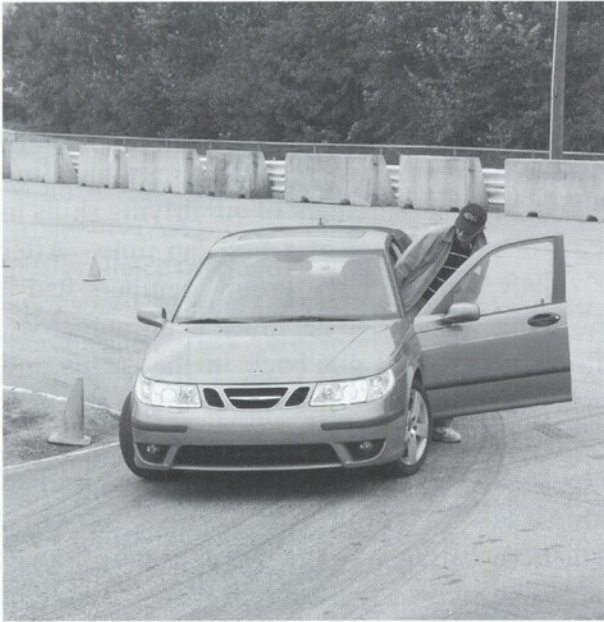

as the skid starts. But this is one of the worst things the driver can do, because it transfers weight to the front of the car, thus giving the back of the car less weight and hence less traction, when the rear end needs all the traction it can get. Like the brake exercise, this was a lot harder and much more fun than expected.

As with all the exercises and, in particular, skid correction, one important element that

performance and offers advice on how to execute the maneuver more effectively. After each person had a chance to perform about half a dozen panic stops, we all piled back into the Aeros again and followed the instructor to the next exercise, the skid pad.

The skid pad is a large expanse of tarmac that has what looks like a giant rotating lawn sprinkler in the middle carving out a wet slick circle. In this exercise an instructor rides in the passenger seat. Initially, the instructor encourages the student to progressively apply more gas until understeer is exhibited. It's amazing how just slowly letting off the accelerator lets the front wheels regain traction and allows the car to start moving in the desired direction. After doing a few laps around the skid pad, the instructor abruptly engages and quickly releases the emergency brake, inducing an oversteer skid. Here is where the skid correction skill of "correct-pause-recover" is practiced. The reaction that is hardest to resist in this exercise is the desire to hit the brakes as soon

the instructors drilled into our minds was to always look at where you *want* to go, not where you *are* going. Our brains do a great job of trying to adjust our actions to move us in the direction we are looking. If you are looking at where you don't want to go (e.g., ditch, guard rail, wall, etc.), chances are you will end up there. Keeping that in mind, however, the instructors also illustrated that not all skids are correctable. If you are in a skid and you find yourself looking over your shoulder at where you

want to be going, you are probably not going to be able to recover from the skid and the car is going to spin. At this point, the last resort action is to apply full brakes.

It's probably worth noting that for most of the skid pad exercise, the ESP was disabled so that we could practice our skills without the help of the safety systems. However, we did get a few chances to experience the skid situation with the ESP enabled. The ESP does an incredibly effective job at controlling the car, but driver action and reaction is still important. Even as wonderful a thing as ESP is, it obviously can't change the laws of physics if you get in too deep.

The skid pad exercise finished up just before lunch. I think we were all ready for lunch, and I was relieved that the skid pad was done. I was a little anxious about going around and around in circles. Thankfully, it all turned out okay and I didn't require the use of a "fear factor" style barf bucket.

### Next issue: Day Two

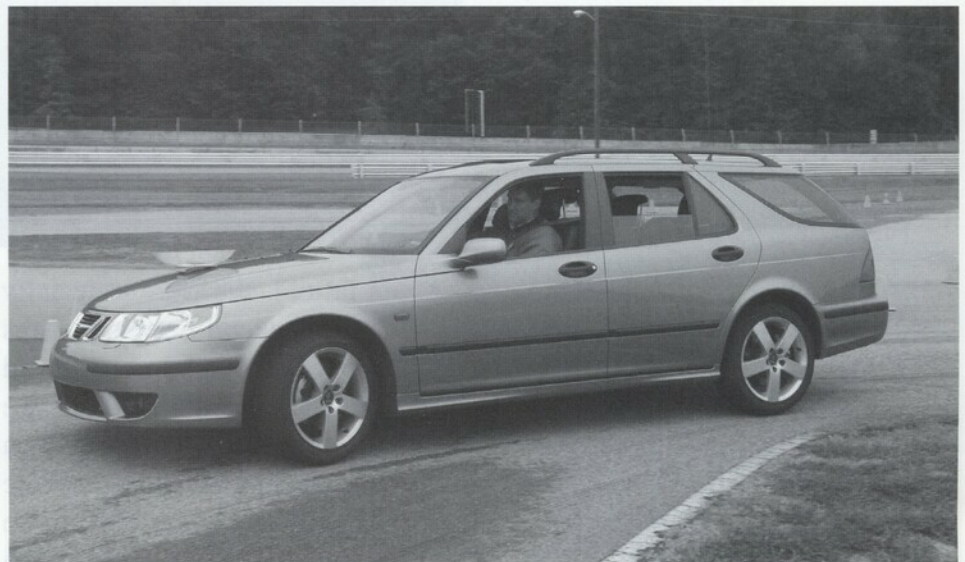



## Club News

### SAAB Fun in the Florida Sun

April 2, 2005, the Saab Club of Tampa Bay hosts the first **Southeast Regional Car Show and Swap Meet**.  
[www.SaabClubofTampaBay.com](http://www.SaabClubofTampaBay.com)

April 7, 2005, **Minnesota Saab Club meeting** at the Backyard Bar and Grill. Located at the south end of the Har-Mar Mall in Roseville, MN, at 7:30 P.M. Jim Miller from Twin City Tire speaks at the meeting.

April 23, 2005, **Great Lakes Saab Club**. Kart2Kart karting track afternoon, Sterling Heights, MI. contact Sean Mullady.

May 7-8, 2005, **Rhinebeck Car Show**, Rhinebeck, NY.  
[www.hemmings.com/index.cfm/fuseaction/events.detail/id/62959/eventid/62959](http://www.hemmings.com/index.cfm/fuseaction/events.detail/id/62959/eventid/62959)

May 20-22, 2005, Carlisle, PA.  
**Saabs @ Carlisle 2005.**

Don Fatzinger reports, "As I said after last year's event, we're shooting for "205 (entrants) in 2005! And with last year's registered turn out of 163 cars, with a bunch more NOT registered, it shouldn't be too hard!" [www.saabclub.com](http://www.saabclub.com)



June 4-5, 2005, Greenwich, CT.  
**2005 Greenwich Concours D'Elegance.**  
[www.greenwichconcours.com](http://www.greenwichconcours.com)

June 12, 2005, Walden, NY.  
**Vintage Saab Club Meeting.**  
July 10th, 2005 Oneonta, New York. Ed Lorenz reports, "It is time again for another 'Even-More-New-And-Improved-And-Better-Than-Ever-Saab-Picnic-In-Oneonta,' brought to you by the Vintage Saab Club of North America." [camedriley@aol.com](mailto:camedriley@aol.com).

July 16, 2005, Claremont, NH.  
**2nd Annual Claremont Saab Run.**  
<http://69.173.102.115:90/saabrun.php>

Early August, Great Lakes Saab Club,

**Woodward Dream Cruise** meeting.  
Contact Pete Tacy.  
August 5-7, 2005, **International Saab Convention, Essen, Germany.**  
[www.astro.ruhr-uni-bochum.de/klw/Saab-Club.htm](http://www.astro.ruhr-uni-bochum.de/klw/Saab-Club.htm)

Aug 11-14, 2005,  
Stratton Mountain,  
VT. **23rd Annual Saab Owners' Convention.**  
[www.nesaab.org/](http://www.nesaab.org/)



Saab Automobile AB and the Swedish Saab Clubs invites you to The Saab Festival of 2005 June 16-19. Saab freaks from all over the world are gathering in Trollhättan, and during these days Saab City is really going to turn into Saab Heaven with stunt shows, track days and entertainment of a rarely seen magnitude.



The Saab Festival will not require any registration and it doesn't really cost anything to participate. On the other hand, you have to arrange for accommodations and other practicalities yourself. The costs associated with the festival, for instance, the track day on Kinnekulle Ring, will be charged on the spot.

You will also get a unique opportunity to make real deals on spare parts not only for your classic Saab but also for your everyday Saab. Saab Development Center for Car recycling, (SDCC) is handling all dismantling of factory test cars, among other things. They are going to have a real garage sale of new, original spare parts from the warehouse in Nyköping with prices you will probably never see again.

So book your June trip to Sweden right away!

**Get your club information listed! Send it to [nines@earthlink.net](mailto:nines@earthlink.net)**

## Saab News

STOCKHOLM -- General Motor's Swedish subsidiary Saab acknowledged that some of its late-model 9-5 and earlier 9-3 automobiles had an engine design fault that could lead to loss of oil quality and damage to turbo-charged engines. The company said it would pay for the repairs, which are not covered by insurance. Most of the affected vehicles were circulating in Sweden, although some had been exported, said a Saab spokesman. He was unable to estimate how many cars were involved, but the daily *Dagens Nyeter* said up to 100,000 vehicles might have to be recalled.

DETROIT -- Saab remains a valuable brand for General Motors, the head of the carmaker's European division said, dismissing a newspaper report that the Swedish unit's future might be in doubt.

"Saab is an important brand for General Motors. It is the only entry premium brand globally, it is one of the few global brands we have, it is almost 100 percent conquest sales for General Motors. So it is of very high importance for us," GM Europe Chairman Fritz Henderson told reporters at the North American International Auto Show.

But he added that GM was looking for ways to improve performance at Saab, in part by expanding its product range. "Having a two-product global brand is not a recipe for success," Henderson said.

Henderson said GM Europe would announce in the first quarter whether it will build its next-generation mid-size car at a Saab plant in Sweden or at an Opel plant in Germany. He declined to say which plant had the inside track for the job. He also said GM was looking at ways to make future production more flexible, perhaps by building some European brand cars in North America.

"You do that typically when you look at new products and new architectures. I think over time we will do more of that. I have been asked the question before: Do you have to build all Saabs in Sweden? The answer is no. You can build Opels in Sweden, too," Henderson said.

## Professional Perspective



### IS SAAB TO BLAME?

When GM purchased the remainder of Saab in the year 2000 it was with great fanfare and promise for the marque. Money was to flow to Saab for new products, marketing, etc. Some of that has happened, but sales and, most of all, profits have not been generated. What we see is just more red ink that Saab has been swimming in for a number of years. As a side note, I realize that some of the red ink can be generated by creative accounting to make a product look better or worse depending upon management's goals. GM's woes at Saab are just the tip of the iceberg. GM's other problems have accelerated corrections at Saab and circumvented the turnaround time for Saab with new products. GM's losses in Europe over the past four years are reported to be more than \$2 billion by Autonet.ca. This loss would include numbers from Saab, Vauxhall, and Opel.

Lest you think that GM is the only one struggling, consider that Volkswagen lost \$1 billion in the U.S. in 2004 and Ford lost \$740 million with its Premium Auto Group that includes Jaguar, Volvo, Aston Martin, and Land Rover. Ford has closed one of the three Jaguar plants in an effort to stem part of the flow

of red ink from its European operations. Increased competition from Asian cars and antiquated labor laws in Europe make things difficult. An example of the problem is the labor cost difference between German autoworkers and even those in Poland. Labor costs in auto plants in Poland are \$7.20 per hour, and in Germany the cost is \$38.10 an hour, according to an article in the *Chicago Tribune*. That is quite a differential, but then compare it to the Chinese built Chery. The Chery is expected to be imported to the U.S. by 2007. Sales are expected to be around 250,000 cars in several model configurations. There are already dealerships being franchised to sell these cars. Labor costs in 2004 were less than 80 cents per hour for the Chery.

Back to Europe: GM knew there had to be changes to save their European operation. GM went to Germany and Sweden last fall and expressed their desire to build cars much cheaper, or else! It amounted to a confrontation or competition between the two countries with the threat that one or the other would possibly lose their GM auto industry. The result was that by November both countries tried to secure a very low bid to retain and maybe gain production from the other's factory. Germany's bid to GM was to cut production costs in half. Sweden's bid (reported in *Svenska Dagbladet* by Andy Butterworth) included an offer by the Swedish government to invest 2.4 billion crowns in infrastructure (roads, etc.), and the factory is to increase car production from 40 to 60 cars per hour. That would bring savings of 20% this year and 20% next year. GM in a press release expressed satisfaction with the bids and said they would announce their decision on present and future auto

production in the first quarter of 2005. They did say that the savings may save both Russelshiem and Trollhattan. It is likely that the cars built on the Epsilon floor pan (9-3 and some Opel models) may be moved to one factory in one or the other countries. This all seems like fairly good news, but GM has other European issues.

In 2000, GM bought 10-20 percent of Fiat. It depends upon which source you read to establish GM's ownership. The problem with the contract between GM and Fiat is an option, called a "put." This clause could be and has been exercised by Fiat to force GM to buy the remainder of its assets and liabilities. The deadline for GM to comply is February 1, 2005. GM has offered \$500 million to get out of its contract, and Fiat wants \$3 billion to sell to GM. Not only would GM have to pay the \$3 billion but also inherit \$10.9 billion in debt from Fiat and a company that is losing millions and millions of dollars per year. GM already has a \$300 billion debt according to information found on the Autoblog Web site.

GM has problems in the U.S. as well as Europe! GM has become the world's largest purchaser of health care for its employees and retirees. Estimates of \$5.3 billion are to be spent in 2005. That is far more than GM spends for steel in production of its cars. To compound the problem is all the unsold cars—overproduction by all manufacturers makes profitability difficult, to say the least. On December 1, 2004, there were 4.2 million (largest number in 10 years) unsold new cars; 1.3 million belong to GM. It has been a common practice for most manufacturers to have a 60 to 70-day supply of new cars on hand. This is now an 81-day

average. Some of the bigger losers, as reported by [www.autoconnection.com](http://www.autoconnection.com), are Honda Insight at 768-day supply, Chevrolet SSR at 301-day supply, Chrysler Cross-Fire at 286-day supply, and Saab 9-3 at 248-day supply. One of the reasons for the high car count is that each manufacturer is trying to protect its market share. The United Auto Workers Union also becomes problematic because they reportedly get full salaries while auto plants are temporarily shut down to counter overproduction, and 95 percent pay for two years after a plant closure. It's not easy to save money if you are a manufacturer. I'm happy to not be in management with any car manufacturer today. Tough days are ahead! GMC Envoy XUV only sold 12,000 units in 2004 and was expected to sell about 120,000. And, the Pontiac Bonneville sold 30,000 units. Saab is not the only member of the GM family with small numbers.

Why aren't more folks buying Saabs? Part of the answer is in the J.D. Power survey that is shown. Poor experience with the car does not tend to encourage another purchase. This is related to residual value. Residual value is usually the value a car has when returned from a lease but could be applied to all cars. Purchase price, resale value, maintenance, etc., are all figured into these numbers. One way to express this number is by the cost per mile. What did it cost to drive a particular car 60,000 miles in 36 months including fuel? *Business Fleet Magazine* publishes these numbers for their subscribers bimonthly. The 2005 9-3 Linear is .3390 cents per mile (CPM). 9-5 Linear is .4097 CPM. Other cars in the entry level and luxury class are Lexis ES330 at .2837 CPM, Mercedes

J.D. Power and Associates  
2004 Customer Retention Study<sup>SM</sup>

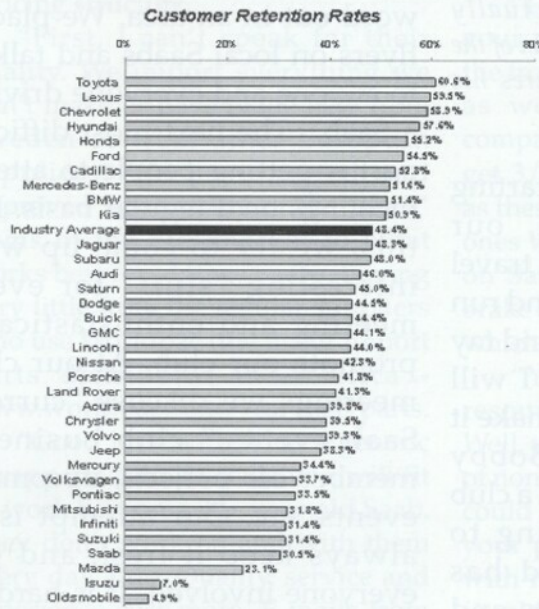

Included in the study, but not ranked due to small sample size are HUMMER, MINI and Scion.  
Source: J.D. Power and Associates 2004 Customer Retention Study<sup>SM</sup>

Benz C240 at .3235 CPM, Cadillac CTS at .2962 CPM, and Volvo S40 at .2310 CPM. Full-sized luxury cars range from .2776 CPM for Volvo S60 to .5056 CPM for Cadillac Deville. Better residual value means the car is worth more in trade. It is cheaper to move into another new car with good residual value. This is a whole subject for another time but needs to be considered. These values are not easy to turn around. The certified used car programs are designed to help build better residual values.

Saab dealers sold almost 1,000 more certified cars in 2003 than in 2004, according to the Dec. 20, 2004 issue of *Used Car News*. If these kinds of numbers interest you, go to [www.edmunds.com](http://www.edmunds.com), where they have a section called TCO, or True Cost of Ownership. You are able to compare the TCO of various cars. The numbers can be very enlightening. Being stingy with technical information and tools just aggravates the whole situation. Happy customers, whether they be

from new or used vehicles, are repeat customers.

I wrote in a previous edition of NINES that GM needed to give Saab something unique to get customers into the showroom. GM already has a concept car that would fit the bill. It is the Opel Astra Diesel Hybrid. This car was shown at the Detroit Auto Show. It is a slick car with interesting technology. It could just as well be badged as a Saab as an Opel, since they could both be made in the same factory in the future. A car like the Astra

would certainly bring people to the showroom.

[GermanCarFans.com](http://GermanCarFans.com)

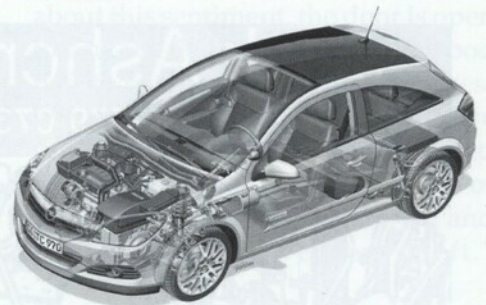

Keep watching the auto news. I tried to write an overview that affects Saab. Most of the manufacturers worldwide have their own problems dealing with issues ranging from money exchange rates to the cost of health care for employees. Many of the issues that GM is facing may already be settled by the time this is printed, but then again they may not be. It is a rapidly changing world. I just hope Saab can keep pace!

## Starting A Local Saab Club

by Alan Fein

*Ed's Note: A number of readers have asked for my suggestions in starting a local Saab club. Having actually accomplishing this feat, Alan Fein of the Saab Club of Tampa Bay shares his ideas.*

I can't take credit for starting the club. Bobby Keen, our president, gets that credit. I travel considerably, and to start and run a club would be a task beyond my consideration. However, I will take credit for helping to make it work, which I enjoy. Bobby apparently started and ran a club in Atlanta before moving to Tampa. My background has always been around cars and specifically Saabs for the past 20 years. We have two Saabs in our house, my wife drives the 1999 9-5 which we bought new, and I have a 1972 96.

One of the most difficult parts in starting a club is getting the word out in an area. We placed flyers on local Saabs and talked to anyone and everyone driving a Saab. The next most difficult part is getting people to attend meetings on a regular basis. For this, we try to come up with interesting "stuff" for every meeting and enthusiastically promote our club. At our club meetings we discuss "current Saab events," club business, member car projects, upcoming events, etc. Our attempt is to always keep it fresh and get everyone involved. It is hard to believe, but we have Saab "crazys" here in the Tampa Bay area, but we still have to send out numerous reminders to members to get them to attend the

meetings. We meet the first Tuesday of the month. At a typical meeting we usually have about 20 of our 35 members present. Not too shabby! After the meeting, we all go to dinner together. Sometimes the meeting is at the restaurant, sometimes it is at the local Saab dealer with whom we have an excellent relationship. We also try to have an event every month. We have had a winery tour, we have participated in local car shows, we have gone to an aircraft museum, and later this month we are having a barbeque/picnic. We are hosting a Regional Saab gathering in April. So, it appears the "secret" is in never standing still.

## Jack Ashcraft's Orphan Saab Parts

phone: 541-779-0731

email: jackashcraft@charter.net

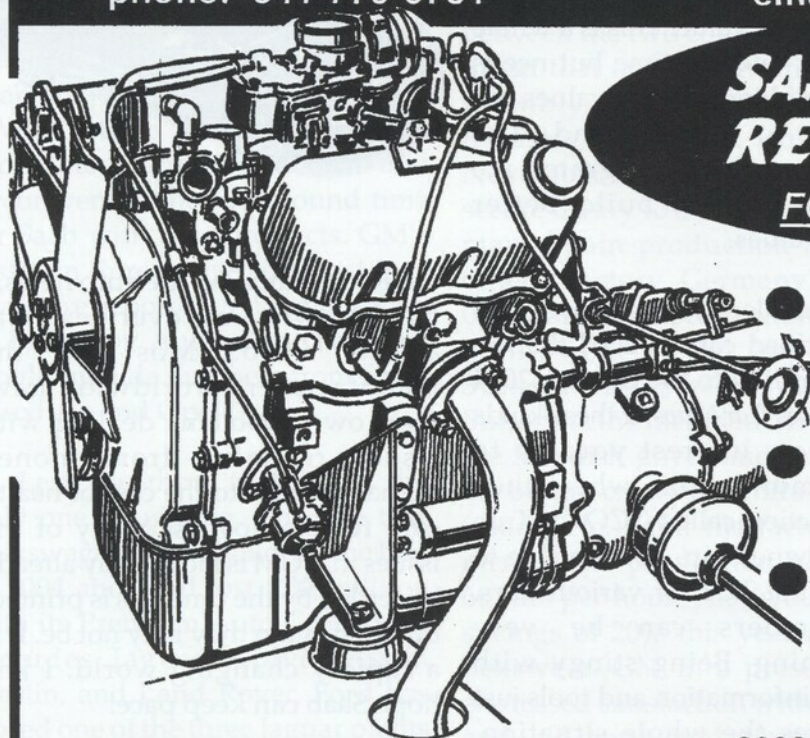

### SAAB V4 ENGINE REBUILDING!

FOR OVER 35 YEARS!

- OUR ENGINES HAVE MANY HEAVY DUTY PARTS, PLUS LIGHT FLYWHEELS, NEW WEBER CARBS, SOLID STATE IGNITION SYSTEMS AND LOTS MORE!
- STREET STOCK UP TO 90BHP OR SUPER STOCK UP TO 120 BHP
- Send for our free ENGINE TECH SHEET & parts catalog!

PAYMENT BY VISA/MC, MONEY ORDER OR CHECK

2030 Grey Eagle Drive, Medford OR 97501

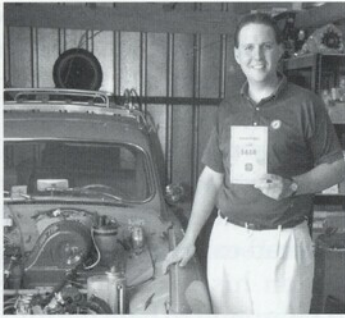

### Dear Chip (or, How I Give Away More Trade Secrets For Entertainment Value)

I've written on this topic before, and it's probably tiresome reading for those of you with newer cars, but this is my column, and, well, so there! Seriously, if you think about it, it's getting hard to find stuff for later 9000s, let alone the stuff that I and a handful of my compadres in Vintage-Land deal with.

To wit, the following was written in response to a parts quote I sent out recently:

"Received your e-mail last week, and was very disappointed at your pricing schedule. I did buy the parts from a company called Import Specialists of America. Their pricing blew you guys away. Also had free UPS shipping on orders of \$75.00 or more. I was very impressed with your very timely e-mail response, and would eventually like to get things rolling with you folks. I have 2 Sonett', two Benzs, two Toyotas and am in the process of buying a BMW. These are my personal vehicles, and as they get older, I will need the resources that you folks provide. You really need to look at your pricing structure.

"Thanks for your time, Dick."

After composing myself enough to keep my reply from turning into just another nasty-gram, here are some excerpts of what I wrote:

"Dear Dick,  
"Let me explain to you my 'pricing structure.'

"First, I can't speak for their quality. We import everything we don't make or have made here from Sweden or from other European suppliers. We have vetted and improved upon many of the 'stock' items in the aftermarket to what works best for vintage Saabs, buying very little from the regular suppliers who use Worldpac (the major import parts distributor in America - [www.worldpac.com/](http://www.worldpac.com/)) for their parts.

"Good luck with what a generic cheapparts.com site tells you will fit or work best on a 30+ year-old Saab. They don't work on and with them every day. I do. Quality, service and experience cost more. E-mails from people like you make me wonder why I don't bother to do just that, and then there will be no vintage Saab-only specialist in the USA standing by to take calls and e-mails from folks looking to keep their cars on the road day after day. It doesn't matter to me if it doesn't matter to you.

"However, I count over 3,000 vintage Saab people who turn to me for not only parts but service and experience in our customer database, and most come back, because they know I am here to help them and stand behind my products, whether they be commonly derived or custom-made. Is that the sort of relationship you would like to have with your vintage automobile parts vendor? Is it worth the difference in price to you? Places like this -- and there are very many of them -- have an online interface which they sell parts for under my cost, because I don't do \$25,000 per month in Acura turn signals and Mercedes oil filters, and probably, per part, for \$1.50 over their own cost. Yet how can a one-man, service-oriented business stay alive at that markup?

"I will not change my parts pricing, except to raise it when the

euro/dollar rate forces me to, as it has continued to do.

"I bet that this outfit you bought your parts from did not have either the front or rear brake hardware kits - as we are the only U.S. based company to carry these. Nor did you get 3/4" bore rear wheel cylinders, as these are not stock Saab items, but ones which I have modified to work on Saabs, and which improve the brake bias on the Sonett and other cars which do not have power brakes.

"You wrote, 'I will need the resources that you folks provide.' Well, you don't get them with the sort of nonsense you wrote me below. You could have had the courtesy to bring your price difference issues to light with me in a phone call or e-mail. I would happily have explained them to you. But I have too many good, regular customers to assist to give away free help to someone with no appreciation for what my time is worth as a parts vendor.

"If you'd like to change my mind about this sentiment, the door is open to you: 804-357-4926. Otherwise, good luck to you -- and I mean it in the best way. I'm not just a parts vendor, I have three vintage Saabs of my own, and at the end of the day, I'm just one of the guys. It's where I came from and it's someplace I've never left."

While e-mail has become a great medium for misunderstandings small and absolutely devastating alike, I think I handled that rather well. I figured I'd air this sentiment with a few of the e-mail listservs I subscribe to, populated by friends and detractors alike.

I haven't had a negative response to this one yet. So I figured I'd publish it in NINES and watch for the storm.

Have a Holly Jolly Rest of Winter!

Yours in insanity  
William "Chip" Lamb  
West of Sweden SAAB  
Richmond, VA

## My Saab 900, Beginning To End

I don't remember when I first started really noticing cars, maybe age 13, but when I did, the car I noticed was the Saab 900 - especially the gray SPG with the three-spoked wheels, ground effects, and spoiler. We had some family friends who were truly a Saab family. At the time they had a late 1980s gray SPG, an older 900, a newer 9000 Aero, and of course a convertible "for fun." I also learned about a magazine named NINES and how the family's husband would disappear into the study every two months when it would arrive.

When I turned 16, I bought my parents' 1986 Ford Escort. I drove this car and this car alone for 10 years up until June of 2001. Needless to say, when I moved to Pittsburgh, the old escort failed the Pennsylvania state inspection so I donated it to Goodwill. This car, by necessity, taught me not to be afraid to look under the hood.

It was September 1999 during my fourth year of medical school near Akron, OH, when I started looking at eBay for Saabs and finally found one that looked like a promising starter Saab. It was a 1989 900, 5-speed, high miles (200,000 the seller said, which actually turned out to be 284,000), gray, and "ran good." It was also in Worcester, MA. The bidding was at \$400. The auction was to end on a Friday night at midnight Eastern time. I went back to the old bachelor pad (I had been married about two months and my wife was understanding) with my four old roommates who stayed in from the bars to lend support and to be entertained by me buying a Saab off the Internet. At the end of the auction I was the winner at \$900.

I then contemplated how to get the Saab to Ohio. The next day, Saturday, I had given up on getting it shipped and contacted the seller about driving the car on a 13-hour trip and just skipping school Monday. Of course he said that it would make it. On Sunday I sat on the phone, making arrangements for a rental car, and also a way to tow the car if necessary. The

smallest vehicle I could rent that could tow a car would be a 17-foot Penske moving van. I made sure not to tell my parents, father-in-law, or friends lest they talk me out of it.

I left from the Akron Canton regional airport with the rental car at about 6 p.m. Sunday and drove straight through to Worcester, arriving there at 5:30 a.m. Monday morning. Coffee and the prospects of getting a Saab were my fuel that night. I remember vividly my first sight of the Saab that morning. It was still dark, with dew on the car. The



**Todd's car in better days.**

seller had to show me how to open the hood, and I remember thinking the fuel injector assembly looked like a vine from the jungle with it being so dark. The seller then said the car wouldn't start but that "it was running fine yesterday." He offered to lower the price to \$400. I wasn't going back to Ohio Saabless, so we went inside and wrote up a bill of sale on the back of some crumpled old piece of paper while I handed over the cash. Oddly, the title was still in the name of the owner he bought the car from, even though he'd had the car for about a year. It had the mileage scraped off (more on this later). Mind you, I had only bought one car in my life (from Mom and Dad) and went about this whole transaction rather hastily. I dropped the rental car off, took a taxi to the Penske rental office about a half hour away, waited two

hours until they opened, waited 90 minutes for them to find a truck, then got dropped off an hour away to where the truck and dolly were.

I finally got back to the seller's house at about 11:30 a.m. I ate half a bagel, had more coffee (that would be all that I had eaten the whole trip). I banged on his door -- he said he would be around to help me push the car up to the dolly -- but of course no one was home. It was warm, and the car was really hard to push; an emergency brake cable was stuck. Luckily a passerby helped me push the car up. Then I realized that the straps to secure the front wheels were lying on the inside with the axles preventing me from putting them over the wheels. I tried to push the car off but couldn't. After some sweat I was able to pull the straps off. After the minor setbacks I was good to go.

Driving that big truck with the Saab in tow is an experience I will never forget! I drove through narrow one-lane construction zones in the pouring rain. I got tired. I even turned around after about 300 miles to take the car back but turned right around because I would not have been able to get back to Akron in time for school Tuesday morning. Right outside Hubbard, OH, off of interstate 80, I had to stop and take a nap at about midnight because I started seeing double.

Finally, at 2 a.m., I arrived in Akron. There was no place to park the truck at my apartment complex, so I drove back the old bachelor pad that bordered an art supply store with a large parking lot. I pulled in and woke up one of my poor roommates and had him help me unload the car from the tow dolly.

Returning the next day, there was a cardboard sign on the car stating the car would be towed because it had no license plates. The car still would not start, so I had the car towed to Ed Wolf Shaker Saab in Cleveland. They told me how to get the key out of the ignition so it could be towed. The car

ended up needing a new computer. I got one from Intercity Autoparts used for about \$300. The mechanics put the car up on a lift and showed me that I didn't make too big of a mistake! After my story they had some compassion for me. I then proceeded to drive the Saab home -- the first time I had EVER driven a Saab.

The first thing I did was wash and wax the car. I soon learned the title was mutilated and thus no good because of the scraped-out mileage. After a week of research and phone calls to the Ohio and Massachusetts DMVs, I was able to get a replacement title from Massachusetts after about a month, but still in the original owner's name.

Massachusetts does not require a notarized signature on a car title, so I could have forged it, but honesty prevailed. I read the Ohio revised code and learned how to get a title issued -- just show proof that you bought the car and go to court and get a new title or get a salvage title. I called the Trumbull County courthouse and they said that it really wasn't that easy. I also learned that it is illegal to buy or sell a car that is not properly registered, which in my naiveté I had done. I thought about calling lawyer friends and even selling the car to a junkyard. A month had gone by with the Saab parked at

my apartment with one of the old Escort's license plates on it. Finally, in desperation, I turned to the white pages at yahoo.com and did a search in Boston of the original owner's last name and just started making phone calls. After about 10 calls, I contacted the original owner's mother who had given him the car. She was very helpful. Hoping she was honest, I FedExed the title to her, she had her son sign it, FedExed it back, and, finally, I had a registered Saab a little over one month after I towed it from Massachusetts.

Exactly one day after the car had legitimate plates and I was driving my wife around town, the turn signal fuse blew. And would continue to blow. The car's temperature gauge would get three quarters of the way up, caused by an old disintegrated radiator. Four months after I got everything fixed, I noticed a big trail of power steering fluid drooling from the car. Through all of this I have read the classic Bentley manual and saabnet.com bulletin boards, letting me do most repairs myself.

While driving today I still look at the Saab's reflection in storefront windows. I am still married to the same understanding woman (who wants a Saab herself when we eventually have a child) and live in Pittsburgh. Two years ago I bought a

second Saab (a black 1989 SPG) as a garage queen but this time from a great Saab family in Greensburg, PA, only about 25 miles away.

As I look back on the ordeal involved in getting my first Saab (now with 298,000 miles), I still get shivers when I recall the journey back to Ohio. Going through that painful process makes me appreciate my Saab that much more. And while my friends and family have one more story to tell to those uninitiated to my love of Saabs, every thing turned out great because I got my first Saab.

Now flash-forward five years, add lots of rust. My wife has bought a new car (Swedish iron but not a Saab) and I have inherited her 1995 Volkswagen Jetta as a daily driver. Four cars are too much, so decisions must be made. The car is too old to sell and not worth enough to make it an honest or worthwhile charitable donation, so I look to the newspaper classifieds -- "junk cars towed, cash paid for some." I call up "Roger" and we schedule a date. Over the next few days I part the car out as best I can outside in the snow, spending those last few moments with the old car. I remove the dash and instrument cluster, the mileage now reading 300,003 miles forever, perfectly symmetric.

I follow the tow truck to the salvage yard along the Ohio River in Pittsburgh and take pictures of the car being "processed." They use a large forklift to lift the car to remove the gas tank. A torch removes the catalytic converter and exhaust that I had spent hours replacing in the past. The forklift rams through the windows, then expertly rips off the hood and, with one of the forks, plucks out the radiator, coolant pouring out like blood. I wanted to cry out "stop!"

I then followed the forklift, Saab in tow now lifeless, to the crusher and watched it flattened. I am sure the old gray Saab will be reincarnated as a 9-3 Aero.

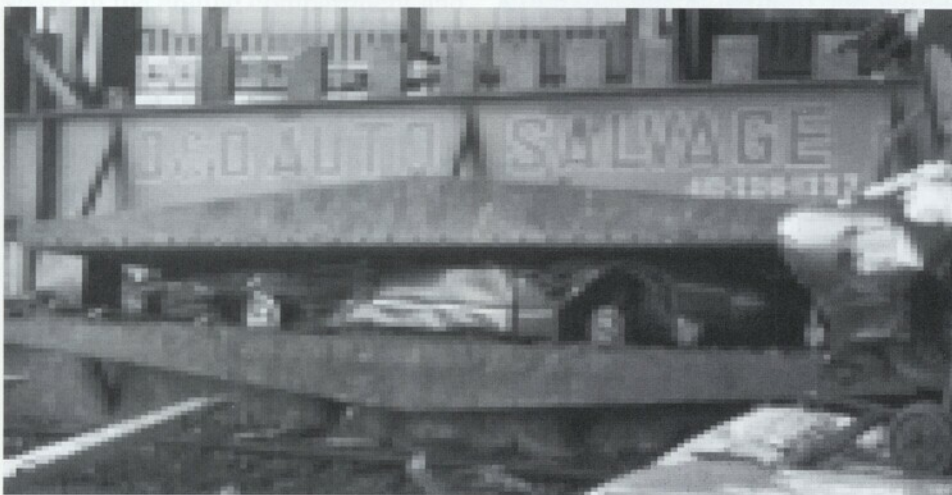

Todd's car on the way to Saab Valhalla. Photos by the author.

# The North American International Auto Show

By Stephen Goldberger

It was again my privilege to attend the Media Days at the North American International Auto Show (NAIAS). As compared to the "public access" days at an auto show, media days have far fewer people, corporate executives rather than attractive young ladies manning the exhibits, and they feed you. There are also press conferences galore; every half hour, complete with loud music, smoke, and mostly the same self-aggrandizing speeches. Beneath the glitz there was plenty for an automotive technophile; cut away engines, bare chassis, and exposed components.

New at the NAIAS Saab display for 2005 was a production version of the 9-7X. The 9-7X shown did not have the EPA and DOT compliance stickers, meaning that it was a prototype. Still, it had production components and presumably was assembled on the production line in Moraine, OH.

The vehicle is generally attractive, with a dash, seating, and control layout much like the 9-5, right down to a 9-5 cup holder on the dash. The notable exception is GM's turn signal stalk mounted light controls. The interior shares the 9-5 SportWagon's inability to lower the rear seat without moving the front seat forward. The appearance and feel of the interior materials are consistent with the quality of Saab's car interiors, and are a distinct improvement over the Chevrolet version. Saab promises a much better driving feel with a lowered suspension, improved brakes, steering rack, front frame rigidity, and a unique tire, wheel, spring, and damper combination. While I was photographing the 9-7X, a team of engineers from Toyota descended upon it, armed with tape measures and checklists.

In production trim, the drive train will include either a DOHC in-line 6

cylinder 4.2 liter engine with 275 hp and 275 ft. lb. of torque, or a pushrod

equivalent fuel economy between the smaller 6 and larger V-8 versions.



**Toyota techs check out the 9-7X at the show.** *Photos by the author.*

V-8 5.3 liter engine with 300 hp and 330 ft. lb. of torque. Both engines feature aluminum block and cylinder head(s). The DOHC engine is a relatively new design, while the V-8 traces its design back to the "small block" Chevrolet engines of the 1950s. With its wider power band, higher specific output, and more modern design, the 6 might be attractive to a Saab buyer, but the V-8 features "displacement on demand," or cylinder deactivation, which results in

The 9-3 Sports Sedan which underwent the Insurance Institute for Highway Safety (IIHS) side impact test was also shown on the Saab stand. In the IIHS side impact test, a moving deformable barrier strikes the driver side of a passenger vehicle at 31 m.p.h. The barrier weighs 3,300 pounds and



**Thoroughly crunched 9-3. Note the lack of deformation on the passenger side of the vehicle in the front view photo.**



has a front end shaped to simulate the front end of a typical pickup or SUV. In each side-struck vehicle are two instrumented dummies the size of a small (fifth percentile) woman. One dummy is positioned in the driver seat, and one is in the rear seat behind the driver.

The Saab fared well enough in the IIHS side impact test to earn a "best pick" rating to go along with the "best pick" rating it earned in the IIHS frontal offset barrier test. What caught my attention was the degree with which much of the body remained unscathed by the side impact. The painted centerline over the hood, roof, and trunk remained perfectly straight. The hood and trunk lid showed no distortion at all, and the trunk-lid to rear-fender gap appeared to be as new. The bonded windshield showed but a single stress crack across the passenger's side of the car. Overall, the Saab's crash integrity is outstanding.

The Subaru stand displayed both cutaway and production samples of their new SUV Crossover vehicle, the "B9 Tribeca," which is said to be the foundation for a future Saab model, perhaps called the 9-2X. Items here which caught my eye included the space in the engine compartment and the suspension and drive train layout. One stated reason for withholding the 9-2X from the European market is the absence of a diesel engine option in that model. The B9 appears to have ample room under the hood for a "V" block, and possibly an in-line engine rather than the horizontally opposed 6 cylinder engine used by Subaru.

The rear suspension is strikingly similar to Saab's independent rear suspensions. The layout is similar to the 9-3 Sports Sedan, with a trailing arm, two lateral links, and a toe correction link. It differs from the 9-3

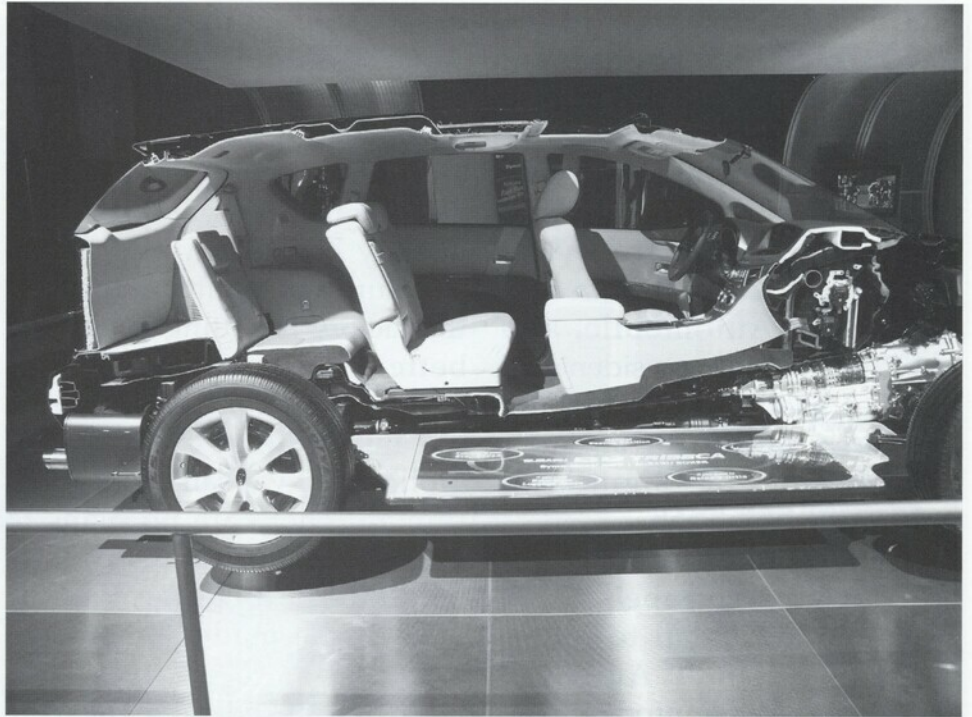

**Cutaway of the new Subaru, which will be the basis for the Saab 9-6X.**

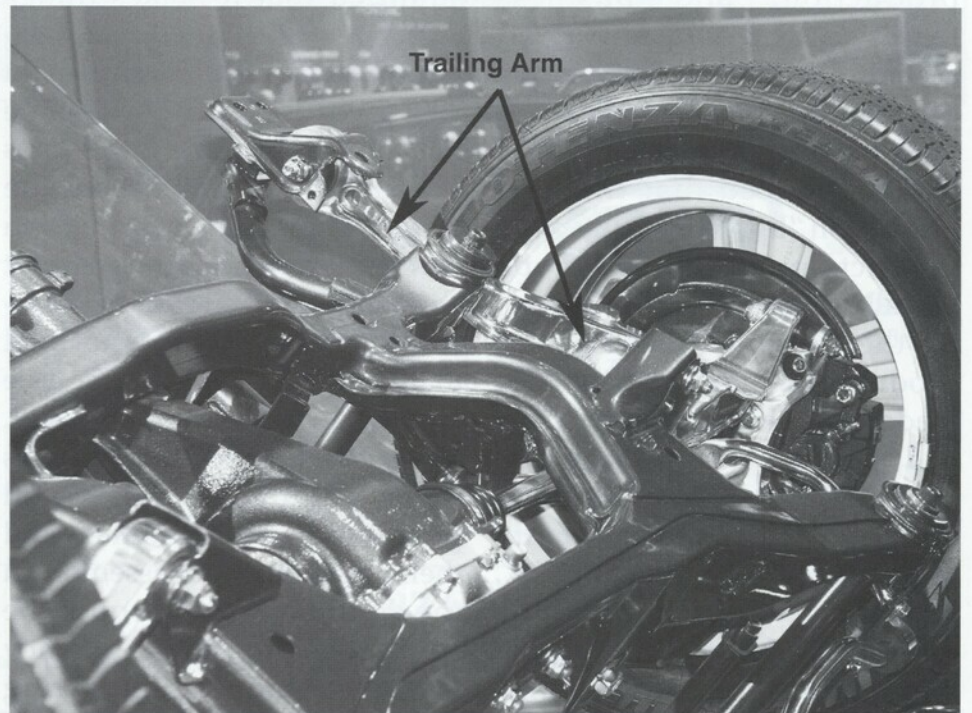

**Rear suspension as designed by Subaru. Note trailing arm.**

in having a heavy cast trailing arm similar to the 9-5, compared to the flat plate arm on the 9-3. The rear subframe mounts to the body in a similar manner and with a similar

geometry as the 9-5. Is the heavier trailing arm necessary for driven rear wheels? If so, this furthers the theory that the 9-5 chassis was designed to accept an AWD powertrain.

During Media Days at the 2005 North American Auto Show, we continued our tradition of interviewing Saab officials. This year we were able to talk separately with Peter Augustsson, GM Europe vice president and Chairman and CEO, Saab Automobile, and Debra Kelly-Ennis, president and COO of Saab Cars USA. Our interviews were made against a background of significant upheaval within Saab.

General Motors is reorganizing Europe's Saab, Opel, and Vauxhall to reflect GM's North American operations. While products can and will continue to be differentiated, engineering, production, and business functions are organized according to function and vehicle architecture, not brands. The most visible example is that GM has announced that the next generation "Epsilon" architecture products produced in Europe will all be made at a single factory. At the present time, Epsilon products include the Saab 9-3, made in Trollhättan, and the Opel and Vauxhall Vectra and Signum, made in Rüsselsheim, Germany.

Here at home, the Atlanta headquarters for Saab Cars USA, Inc., has been closed, with the functions and some of the people being transferred to General Motors' Detroit area facilities. Saab's sales have declined by about a quarter from their record year, and the 9-2X has produced disappointing sales numbers.

Asked about the prospects for producing the next "Epsilon"

based models in Trollhättan, Augustsson said, "We have made our proposal, Rüsselsheim has made theirs, and General Motors will make their decision in the first quarter of this year. We already have a very good cost structure and quality rating, and the factory is getting better and better, so we are hopeful of receiving the contract. If we do not build the next Epsilon in Trollhättan, we can build other things. There are no plans to close the Trollhättan factory. If we do get the next Epsilon, then the 9-5 will be made somewhere else."

When asked how the U.S. dollar's decline against the euro has affected Saab, Augustsson admitted that it makes things difficult. He asserted that Saab pulled back on its incentives in 2005 because of the exchange rate, one cause of the lower sales volume. I asked about the prospects for assembling 9-3s in North American factories that were already building Epsilon-based models. Augustsson said that having a local supplier base would be a primary requirement. Most of the cost of the vehicle lies in its component parts and purchased subassemblies, and their importation for assembly in the United States would be subject to the same currency factors faced by importing assembled vehicles.

Saab's 2004 European sales fared much better than in the United States, with around 80,000 units representing a record for sales.

One interesting fact about Detroit -- once you are there -- they do not want you to leave. I was there for the North American International Auto Show in January (see previous reports by Stephen Goldberger), but it was the leaving that will stay with me.

As I left the convention center parking lot, I asked the nice lot attendant how I could get to I-75 South and begin my drive home. "Simple," he said. "Just go to the end of the ramp, to Jefferson Street, make a left and follow it."

At the end of the ramp, at Jefferson Street, I noticed that making a left would take me through the convention center building itself. That would not do. I took the next available left, and eventually found myself starting at Canada.

Don't get me wrong, I like Canada. I've been to Canada a few times, and enjoyed myself every time. However, since I had not planned to visit Canada on this trip and thus did not bring my passport, I was not looking to take a bridge or tunnel to Canada (they have both. I found both). I pulled into a gas station near a customs inspection area for trucks. "How do I get to I-75 South?" I asked.

"Simple," the gas jockey said. "Just go to the second light, Rosa Parks, and make a right."

So I did that. I went to the second light and found Rosa Parks, and looked to the right. Sure enough, there was Canada.

So I did the only logical thing. I made a left on Rosa Parks and drove straight through town until I found I-75 South.

They may not have lots of helpful directions in Detroit, but another thing that is in short supply is foreign cars. Not just Saabs, but you've got to look long and hard to find a Lexus or a Honda. One car they have is Azteks. Lots of Pontiac Azteks. Go figure.

-The editor



**Miss the suicide doors on your vintage Saab, but prefer a convertible? Rolls-Royce has the car for you! A model models the passenger's door on this EX100.** Photo by Seth D. Bengelsdorf.



Welcome to the state of independence

# We've got you covered from East to West.



Enjoy your flight!

## JMK SAAB

Route 22 East  
Springfield, NJ  
1-866-301-1111 Ext. 491  
jmksaab.com



### 10% PARTS & SERVICE DISCOUNT

FOR CLUB MEMBERS  
Excludes already discounted services

Never Compromise!

## SAAB of HUNTERDON

Route 22 West  
Lebanon, NJ  
1-866-865-1907 Ext. 450  
saabofhunterdon.com



New and Used SAAB parts  
VISA/MASTERCARD ACCEPTED  
TOLL FREE ORDER LINE  
**1-800-882-7220**

Info: 763-631-Saab Fax#: 763-389-3875  
3558 Brickton Road, Princeton, MN 55371  
www.andrewsofprinceton.com  
E-mail Chuck@andrewsofprinceton.com

## Paragon Performance

The Leader in High Performance  
Automotive Hose, Fittings and Adapters

**We Specialize in Saab Stainless Steel Braided Brake Line Kits!**  
Prices Start at \$77.00 for a 4 line kit

We also offer Stainless Steel Braided Hose, Aluminum Fittings and Adapters for Fuel, Oil & Transmission Lines

Come visit us at:  
<http://www.paragonperformance.com>  
**1-800-270-0333**



Exclusively  
**SAAB**  
Since 1969

**Rust Free Used Parts**  
There is NO RUST in Colorado  
125 SAABS TO PICK FROM

**1-800-757-7222**

519 Lipan St - Denver, Colorado 80204-4906  
Phone (303)595-4646 - FAX (303)595-0124  
www.milehibodyshop.com



## SAABPARTSDIRECT

Discount OEM & Aftermarket Saab Parts at Unbeatable Prices

**GUARANTEED LOWEST PRICES! FREE SHIPPING on orders over \$40**

- \* Lamps & Lenses
- \* Brake Parts
- \* Clutches
- \* Cooling/Heating
- \* Electrical
- \* Filters
- \* Fuel Systems
- \* Steering/Suspension

ORDER ONLINE: [www.SAABPARTSDIRECT.com](http://www.SAABPARTSDIRECT.com)  
or CALL TOLL-FREE: **800-871-3619** M-F 9am-6pm

**"WE'RE THE SAAB PARTS EXPERTS, SO YOU DON'T HAVE TO BE!"**

## PCV SYSTEMS—V4 WITH TWO BARREL CARBURETORS—PART 3

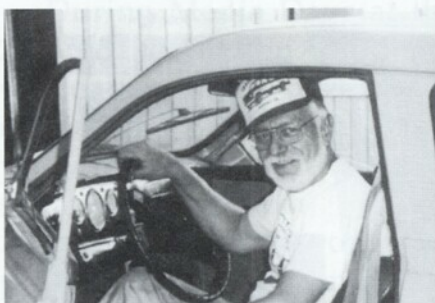

The PCV valve must be installed in the number three intake manifold runner, as was described in Part One. There is slightly less space at that point in the number three runner because the mounting pad for the two barrel carburetor encroaches slightly on that runner. Center the hole for the PCV valve in the space you have, but the same distance from the

valve cover mounting lip.

### THE INTERMEDIATE PLATE

The intermediate plate will NOT be used. Instead, install a 3/16" isolation spacer for a Holley Weber two barrel carburetor, with a paper gasket on each side of the spacer.

### PLUMBING—ALL V4 CARS EXCEPT THE SONETT V4

Left side—make up a hose/pipe system like the one shown here.

Right side—the modification is to the AIR CLEANER. A hose attachment pipe must be fabricated and welded to the base of the

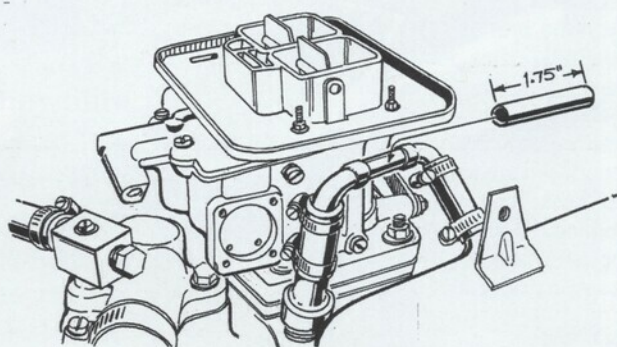

rectangular air cleaner. A small bit of the mounting lip of the Weber 32/36 DGV 5A carburetor must be sawed or filed off, as shown. The dimensions for the hose attachment

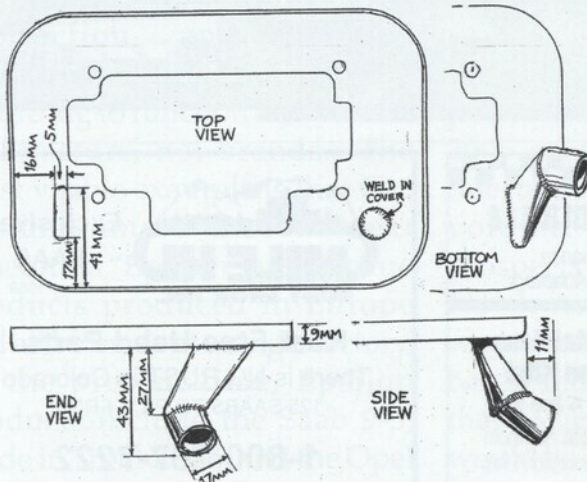

pipe are shown in the drawings. A thin plate must be welded in place over the hole in the air cleaner base. This

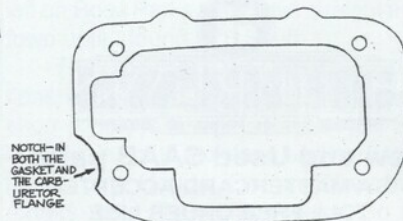

hole was for mounting a hose fitting for the application on some other car.

### PLUMBING—SONETT V4

Left side—make up a hose/pipe system like the one shown here. Note that this system is routed around the FRONT of the 32/36 DGV 5A carburetor.

Left side—air cleaner modification. A hose adaptor must be added to the base of the rectangular air cleaner, similar to, but not at the

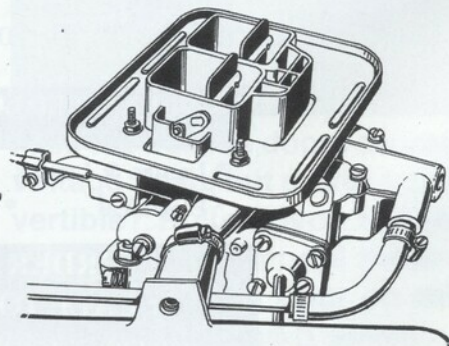
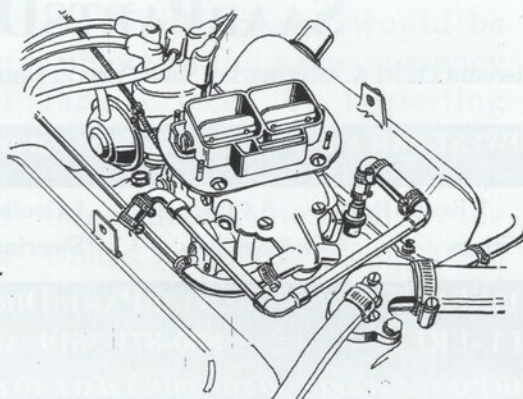

same angle as, the modification shown for the Sonett III/95/96 installations. The dimensions for the hose attachment pipe are shown in the drawings. A thin plate must be welded in place over the hole in the air cleaner base. This hole was for mounting a hose fitting for the application on some other car. A small bit of the mounting lip of the Weber 32/36 DGV 5A must be sawed or filed off, as shown.

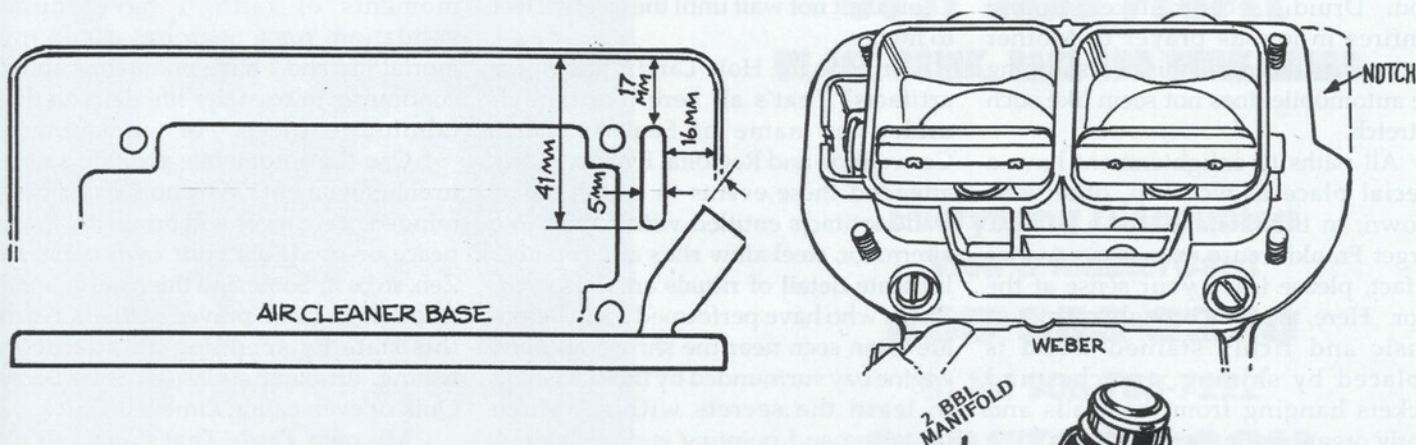

**PLUMBING FOR OTHER TWO BARREL WEBER CARBURETORS**

Use the examples shown and make the system work in a similar fashion. Other Weber two barrel carburetors may have different air cleaner mounting flange patterns, so the location for the hose adaptors may be slightly different. The system must FUNCTION in the same fashion, however.

**PLUMBING FOR POWER BRAKES**

A hole must be drilled into the Number four runner of the intake manifold for a fitting for the power brake hose. This hole is drilled in the rear VERTICAL face of the runner, at the location shown. Use a 1/4" drill to make a pilot hole, then a 27/64" drill for the main hole. Have a helper hold the nozzle of your shop vac right at the area where you are drilling. Hold the drill just at just a slight angle above horizontal, as shown. Tap 1/4" NPT threads in the hole, using the shop vac nozzle at the hole as you tap the threads. Install a 1/4" NPT fitting with a 3/8" hose nipple into the threaded hole, using No. 2 Permatex on the threads.

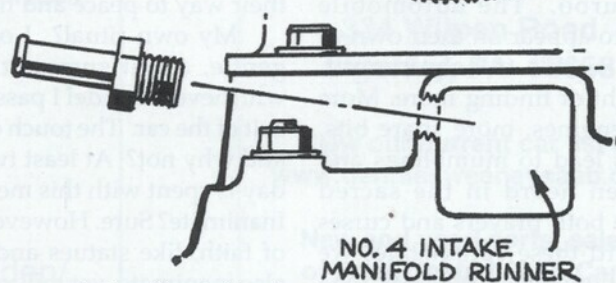
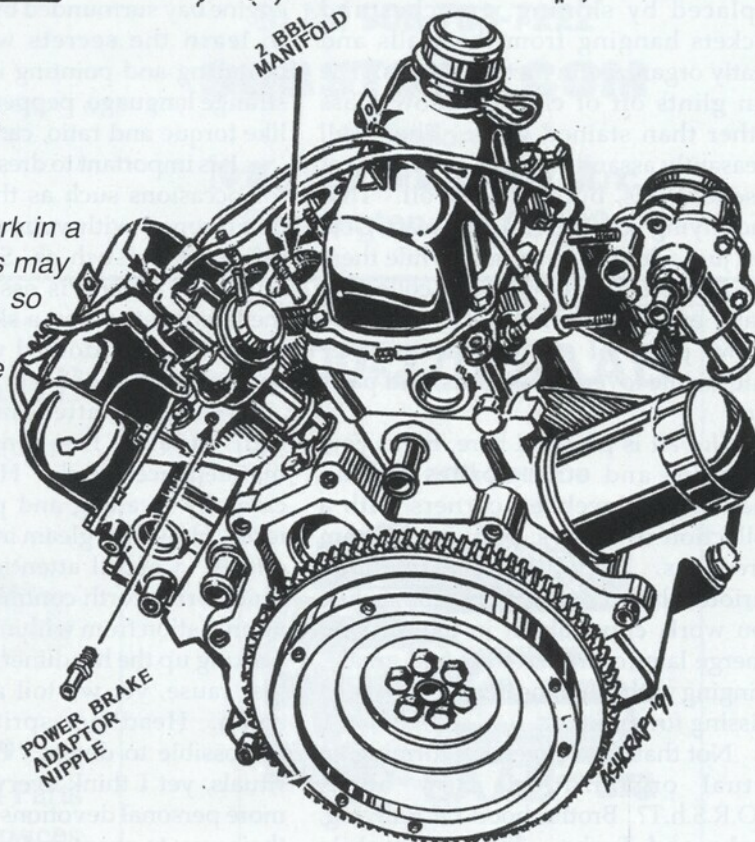

NOTE: There isn't a lot of room in this area, so plan your drilling carefully.

Jack opened one of the first Saab dealerships in California. A professional artist, he owns and operates a Saab parts business.

## Holy Saab

Throughout history, mankind has worshipped a plethora of deities. The ancient Romans and Greeks had gods for everything from love to the underworld. Native American tribes paid homage to the spirits of the animals they killed for food. Druidic sects frolicked around bonfires in joyous prayer to Mother Earth. Considering all this, worshipping the automobile does not seem like such a stretch.

All paths to enlightenment have a special place of worship, otherwise known, in this instance, as a garage. Forget Frankincense or incense; matter of fact, please leave your sense at the door. Here, the calm brought on by soft music and richly stained wood is replaced by shining wrenches and sockets hanging from the walls and neatly organized in metal drawers. The sun glints off of clear window glass rather than stained glass. The smell pleasantly assaulting your nose is not of essential oils, but of motor oil. That underlying scent? It's Lava soap, Gojo and just a hint of gasoline. While there is no visible donation box or collection plate, every spare inch of shelf space shows proof of offerings from other automobile lovers, junkyards, and parts cars.

Not all is peaceful here, mind you. Gremlins and other sprites hide in shadowy, cobwebbed corners with a collection of screws, bolts and 12mm wrenches. They are aided by small curious children and pets who, while you work, crawl about in the din and emerge later coated in dust and grease, bringing with them the item you've been missing for months.

Not that I'm suggesting forming an actual organization. How about B.O.R.S.h.T? Brotherhood Of Rallying, Saabs and Turbo. The automobile shrines seem to appear on their own as if the owner, unable to help himself, dreams at night of finding more. More Saabs, more engines, more spare bits. These dreams lead to mumblings and chanting often heard in the sacred garage, where both prayers and curses directed toward these automobiles we love so dearly flow freely. Whereas Yoga practitioners chant "Om" to find their center, perhaps somewhere a sect of

automobile lovers sits comfortably in a garage softly chanting, "Vroom."

Yet, if such an organization existed, I would wholeheartedly appreciate these edicts: Thou shalt use a blinker. Thou shalt not drive 25 mph in the fast lane. Thou shalt not wait until the last five feet to merge.

Trips to the Holy Land? Search for artifacts? That's all here too, though under the name of Saab Owners' Convention and Regional Events. Many attended these events to search for or trade artifacts entitled with names like alternator, steel alloy rims and roundel. Intricate detail of rituals are discussed. Those who have performed them before are often seen near the shrine, an open engine bay surrounded by those wishing to learn the secrets within. Much gesturing and pointing is done here. A strange language, peppered with words like torque and ratio, can be overheard.

It is important to dress appropriately for occasions such as these. Clothing emblazoned with your particular tribe information, such as Saab, Saab 900, Turbo! or Scania is essential. Lucky members get to don a skillfully crafted helmet of war adorned with horns and symbols of the Saab.

When not attending gatherings, individuals frequently perform maintenance rituals. Hours are spent carefully cleaning and polishing these idols. How they gleam in praise of these efforts! Careful attention to essential fluids bring forth continued rumbles of appreciation from within the engine bay. Tacking up the headliner appears to be a lost cause, yet we toil at it again and again. Headliner sprites are almost impossible to defeat. These are usual rituals, yet I think everyone has a few more personal devotions that encourage their way to peace and harmony.

My own ritual? I offer my Saab a gentle, albeit surreptitious, touch to whichever roundel I pass on entrance or exit of the car. The touch of a dear friend, and why not? At least two hours of my day is spent with this metal companion. Inanimate? Sure. However, many objects of faith, like statues and pendants, are also inanimate, yet millions pay respects to them daily.

Do not chide me for mocking religion, for that is not my intent, nor do

I intend to present the auto as a way to eternal happiness, only as an item worthy of a bit of worship in the mortal realm. Faith is expressed in a multitude of ways, some of which are never validated. Here however, in these daily moments of faith, I have found validation, for a Saab has saved my mortal life and I have no qualms about continuing to trust my life daily to this fabulous piece of machinery.

Can the automobile provide a path to enlightenment? Why not? I am open-minded. Whatever will bring you inner peace or produces your own personal Zen, so be it. Some find this state of mind through Yoga or prayer. Others reach this state by spending an afternoon fishing, drinking a glass of Strawberry Quik or even eating Lime Jell-O.

My own Zen? That's easy. It all starts with the slightly off-key "meep-meep" sound of the key fob unlocking the doors of my Saab 9000. A smile forms as I settle into the supple leather seat of a sun-warmed interior. My eyes gently shut as I start the engine and breathe deeply, relishing that fabulous leather smell. Ahh, Saab-smell. Feel the Zen approaching? Sliding back the moonroof is almost essential to my achieving inner peace, though a substitute of gentle rain or falling snow is equally pleasing. A light touch to the radio controls brings forth calming music, AC/DC, from the Harmon Kardon stereo. (What? Did I not chide the people finding inner peace with Lime Jell-O? Kindly allow me AC/DC. It is unparalleled for stress reduction.). Finally, the very last step brings forth a bliss that some people seek their entire lives without finding, that steady acceleration followed by the sweet feel of boost forcing me slightly back in the seat. Ah, sweet Saab, how I love thee.

I'll be sure to wave at you while I drive down my road of happiness, and best of luck finding your own. I hear there's a sale on Lime Jell-O this week.

*C. Calhoun lives in Toledo, OH. Her Saab collection includes a C900 always in need of parts, a shiny black 9000 and, purely by coincidence, a dog named Troll.*

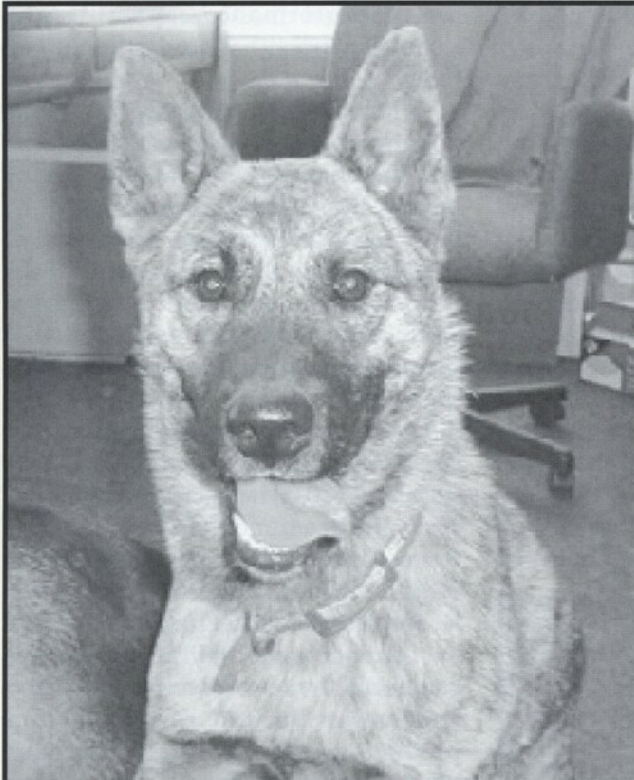

**MY DOG DAX**

**SOB STORY SAAB PARTS  
NOT AN ONLINE COMPUTER  
JUST SAAB PEOPLE**

**WE EAT, DRINK, RACE AND DRIVE SAABS**

Everything Discounted  
Visa & MasterCard

**800-583-0370**

in NJ 908-788-7222

**SOB STORY.COM**

A Division of:

**Moncrief Marketing, Inc.**  
Flemington, NJ 08822

**WEST of SWEDEN SAAB**

*specializing in the two digit Swede*

**William C. W. "Chip" Lamb**

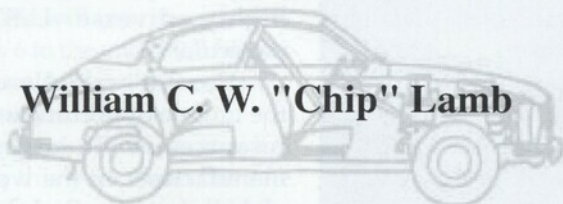

Supporting Models 93 Through 99  
New, New-Old-Stock, and Good-Used Parts  
Restoration and Vehicle Inspection Services  
Friendly Helpful Advice

**Call Us Today!**

tel: 804-357-4926

e-mail: [chip@wmsbrg.com](mailto:chip@wmsbrg.com)

web: <http://www.wmsbrg.com/sweden/>

**800-270-SAAB**

Parts and Service



334 Wilpen Road  
Ligonier, PA 15658

View our current car list at  
[www.dennissweeneysaab.com](http://www.dennissweeneysaab.com)

New and used parts, sales  
of Road Tested Saab Cars

Service in Greater Pittsburgh  
area and points east

## Saab In 2005

*Debra Kelly-Ennis, president and COO, Saab Cars USA, spoke to the Automotive News World Congress on January 18, 2005. Below are excerpts of her talk.*

At the start of 2005, we are gearing up for our biggest product launch year ever -- what a perfect fit with our strategic direction for Saab!

I think I can safely say that Saab has experienced some adversity in its 57-year history as an automaker. From the very beginning, Saab has been a small, niche manufacturer, in an automotive world that runs on volume and economies of scale. We are literally the David in an industry of Goliaths.

The fact that we've endured is a testament to the talents and inventiveness of our people. People who have stepped up to the plate time after time, rising to the occasion when others might have just walked away.

Let me give you a couple of examples.

In 1967, when pending U.S. emissions legislation ended the viability of our original two-stroke engine, Saab engineers went to another manufacturer to find an appropriate replacement. That led to the adaptation of the Ford V4 for the Saab 96 and Sonett models.

It was an apt low-cost solution to a challenge that almost meant the end of production at Saab.

When Saab was looking for a suitable powertrain for its new 99 sedan in the late 1960s, we again went outside Sweden -- this time for an in-line four cylinder. This "arrangement" allowed us to get that car to market when we desperately needed it.

It takes talent to innovate. Saab has a list of firsts that is the envy of the industry. Over the course of 40 years, we have built a solid heritage of innovation with the first seat belts as standard equipment, the first dual diagonal braking system, the first headlight washer/wiper system, the first electrically heated seats, the first side-impact door beams, the first mass-produced turbocharged passenger car, the first active head restraints, and the

first asymmetrically turbocharged V6 engine.

Take that kind of originality, and then factor in Saab's commitment to distinctive, aerodynamic styling, driver-in-control performance, thoughtful versatility, and occupant safety and all-weather capability.

Put all that together, and you can begin to understand why the Saab brand generates so much passion among its employees, its dealers and, most importantly, its customers.

Saab owners are confident, independent individuals. They not only love Saab for what it is -- they also love the brand for what it does not say about them. Here are a few quotes that



**The author at the National Saab Convention, 2004.** Photo by Seth Bengelsdorf.

come directly from our consumer research:

"Saab -- I think it is the most unusual car, starting from where you put the key, the nifty cupholder and the night panel, as a reminder of the fact that they also make airplanes."

"I am a Saabaholic, having owned nine Saabs in the past 14 years. There is no doubt in my mind that driving a Saab gives me the best combination of

safety, performance capability and luxury features that are in the market today."

"Most other luxury cars are being bought by people who want to prove that they have a lot of money. But by buying a Saab, you show that you don't have to prove anything to anybody."

Now this is the passion that we need to leverage. It is the essence of Saab. Our task is to leverage that passion and extend the brand into new segments.

Let's keep in mind that Saab is a small company by any standards. We sell about 130,000 vehicles a year in over 50 countries around the world. The U.S. represents almost 30 percent of Saab's total volume, which makes us the largest single market for Saab.

Almost since day one, Saab has been only a one- or two-car franchise. Driven by limited resources, our products were characterized by very long life cycles. We weren't in a broad enough variety of segments to take advantage of new trends, like SUVs.

And therefore, we've remained small and subject to volume fluctuations. So the challenge is this: given our situation, how do we meet the demands of so many markets -- and the unique requirements of the big and highly diverse U.S. market in particular?

How? It's called leverage. Saab has the unique opportunity to leverage the resources of the largest automobile manufacturer in the world. For Saab globally and for Saab in the U.S., this opportunity presents the best asset that we have for meeting our growth imperative. And like at every other critical point in our history, we will approach this opportunity with both innovation and intelligence.

We need to get from what I call "base camp" -- where we are today -- to the Saab "summit" -- our vision for Saab as a strong, global brand with a healthy volume, and able to take advantage of our premium position.

Now, the key to any successful climb is a having a strong foundation to anchor your ascent. In our case, that foundation is the story behind our



brand. In essence, Saab has been and will continue to be the Statement of Individuality. This is only natural when you look at our unique blend of Scandinavian roots and aircraft heritage.

There simply is no other automotive company like Saab. Our history is the source of our strength to succeed in the future.

We bring to the market a distinctive interpretation of a premium European vehicle, delivering progressive design and driver-focused performance, while being surprisingly practical and safe. It's no surprise that we attract individuals who are not satisfied with the status quo.

Starting with the introduction of the 2003 9-3 Sport Sedan and followed by the 9-3 Convertible, we broadened our appeal from the traditional Saab buyer to new, entry luxury intenders. We'll further expand the lineup with an entirely new body style, called the SportCombi. It is based upon the Sport Hatch concept car that was a hit during last year's auto show season.

We think this innovative hatchback will draw not only traditional Saab buyers but also new customers who are looking for more versatility, more distinctive design and more performance. We will introduce a new turbocharged V6 to the entire 9-3 family. It has 250 hp and, more importantly, tremendous low-end torque.

Bottom line: just looking at what we're bringing this year, Saab has one of the quickest growing portfolios in the industry.

But, you may ask, given your small size, how do you handle that financially? Which leads me to our second challenge that we need to face: currency fluctuations.

For the longest time, Saab has produced cars in Scandinavia only. However, fluctuations in the value of the Swedish krona and the euro produced wild swings in the financial position of Saab. Just like many other European brands, building in only our home market has severely impacted our profitability.

To overcome that, and in timely conjunction with the growth of the portfolio, we're now spreading our manufacturing operations to several continents. This year, Saab will be manufacturing vehicles in Sweden, Austria, Japan and the United States. This will put us in a better position to weather the currency exchange issues. It will be a big help to give Saab's financial picture more balance and stability. And this, in turn, will help fund our future product development.

As stated before, the entry premium market is growing, and is projected to continue to grow. Having said that, there are a lot of very aggressive and worthy competitors out there. Every one of us is clamoring for sales. Every one of us is vying for a clear, recognizable brand statement.

That brings us to the next big landmark in our journey to the "Saab Summit," communicating a unique brand identity.

Saab has always been a brand that has challenged convention, and oftentimes designed things a bit differently. But always for a reason - to benefit the driver, first and foremost. Whether it is turbocharged engines that deliver performance and fuel efficiency, or logical positioning of instruments to minimize distraction.

The common ground between Saab and our target prospects is "independence." But our challenge is, How can we make our brand more widely known to more people? The world is becoming more and more the same. And people of all walks are becoming conscious of it, and doing their part to maintain their identity in an increasingly homogeneous world.

That's our opportunity right there. Saab, from the very beginning and equally so today, is "the antidote to sameness." We believe that by communicating this reality, we will help more people discover Saab's relevance to them.

Bringing us to the next item on our action plan, we need vehicles that are true to the Saab brand as we maximize our opportunities in each market.

As an example, we know that almost 40 percent of our customers here in the U.S. have an SUV of another brand, right next to the Saab they own in their garage. No less than 30 percent of our customers who leave the Saab brand migrate to an SUV as their next vehicle of choice.

We just can't afford to miss these kinds of near-term opportunities in this extremely competitive marketplace. We have to support our dealer network right here, right now, while we are working full speed on the further expansion and renovation of the Saab portfolio.

That's why we engineered our newest entry, the 9-7X, from an existing product to get quick, high-quality access to a large, vibrant segment of the market.

The 9-7X is yet another example of Swedish ingenuity "getting outside of the box" and reaching for creative solutions to challenges in the marketplace, like the V4 in 1967 and that original engine for the 99.

From a brand standpoint, we are engaged in a total revamping of our retail facilities. I think you'll agree that this kind of retail environment is a perfect fit for the Saab brand. More than 60 percent of all Saabs are now sold in facilities like this. Of our 250 stores nationwide, almost half have been or are being built in anticipation of our future products. A great vote of confidence, I think, from a fantastic group of dealers.

Having said that, a great showroom and service facility mean nothing if the customer experience is fair or poor.

A premium customer experience begins on the showroom floor in the sales process. But as the old saying goes, service sells the second, third and fourth cars.

Which brings us back to where we started. Getting Saab to the summit, and the next one after that, demonstrating and then fulfilling Saab's market potential, and Saab's prospective uplift within the GM portfolio.

Well, if there's one organization that's got heart, it's Saab.

That counts.

## Good Bye Older Friend

By *Mike Blija*

After many weeks of procrastination (and perhaps the wettest spring in Wisconsin since Noah built the ark) I finally started parting out the rest of my platinum blue 1987 900S 3-door. The engine and gearbox were already gone, living on in the 1987 900S 4-door I purchased a year and a half ago. The 3-door also donated the power steering rack, drive axles, front brakes and MSS exhaust to that project. However, the body was in sad shape and the only things worth keeping were various interior bits and trim items like the headlights and grille.

The car had been parked next to our garage for several months, and the neighbors were casting wary glances down our driveway, half expecting me to start adding broken washing machines and used tires to the front yard. I aired up the tires and pushed the car onto the driveway by twisting the tires straight (remember, no power steering rack) and stopping the car by dropping short pieces of 2x4 at regular intervals. I grabbed a few wrenches and screwdrivers, opened the driver's door, and set about removing the dashboard.

I always liked this car. My wife, Susan, bought it a few months before we were married some 10 years ago as a replacement for her 1989 Eagle Premier sedan. That car had serious quality problems, coupled with a seemingly reluctant dealer-support network. I have forgotten most of the problems associated with that car by now but the greatest hits included two transmission replacements (under warranty), various dashboard bulbs and displays, a complete exhaust system, air-conditioning compressor and hoses, heater core and fan, both drive axles and the

key/ignition switch (\$125 for just that item!)

Parts can, and will, fail, but they shouldn't drop out with such frequency on a four-year-old car with less than 60,000 miles on the odometer. This was on top of normal wear items like brake pads and coolant hoses. As a final straw, the car would not start every three of four days so it was left running if possible. Visits to two different dealers and three local garages failed to diagnose the problem.

Susan decided she wanted a different car and asked me if I would help her find "something better." The only search criteria she stated was that the new car needed "a manual transmission and a Saab badge on the hood." I couldn't believe my ears! She actually wanted to drive a funky Swedish car like mine, as I was well into my third year of Saab ownership. The crowning moment for her conversion came when she borrowed my ratty 1980 900 GLi for a quick run to town in the middle of a snowstorm. The roads were covered with a thick layer of slush and the temperature was dropping rapidly, causing ice to form in some of the bridges and curves. When she had returned, she came through the kitchen door and proclaimed, "I love that car, I was passing everyone like they were standing still and it handles really good on the ice and..." I held up my hand to interrupt her speech and said, "I know," as calmly as possible, as if she was last to know some great secret. Picture a prospector in California, circa 1850, when someone bursts into a saloon shouting, "There's gold in them thar hills!"

We started searching the classified ads in the Sunday paper and calling several Saab dealerships, hoping to find a good replacement. A couple of months went by and we had driven a few cars, but none of them had that "just right" feel. Finally, on a cold February day, we found ourselves on the north side of Milwaukee, and as we drove past a car dealership, Susan spotted a platinum blue 900 3-door parked on the end of a long row. We pulled in and took the car for a drive, stopping to poke and prod at the various underpinnings with the help of my cousin, who never turns down a chance to test-drive a Saab. On the way back to the dealership Susan looked at me and said, "We're done looking, this is the car I want."

Our salesman asked if we had anything as a trade-in, and we told him we had a fairly low-mileage Eagle Premier. He made a face as he thumbed through his Kelly Blue Book, saying, "We've had a problem selling those cars. Nobody wants to deal with all of the problems, like the transmissions going bad." I cleared my throat and tried to look surprised, but it was useless; he knew. In the end he finally relented and agreed to take the Eagle, and we made plans to pick the Saab up the following week.

We drove the Saab home and made good use of the hatch with the seats folded down when we moved later that year. My father-in-law, a self-styled automotive enthusiast in the "a-car-needs-to-be-practical" vein, was amazed when I folded the rear seat down and slid a full-size clothes dryer in on a sheet of cardboard before closing the hatch.

Later, on our honeymoon, Susan and I slept in that same space when we arrived at our campsite and realized someone (I will not mention

any names here) forgot to pack the tent poles for our brand-new 2-person backpacking tent. She still reminds me of my mistake to this day.

The following year we took the car to several ice trials on Lake Sinissippi to slide around and slap snowbanks with the rest of the Milwaukee Saab Club gang, having loads of fun and laughing like kids that borrowed their parents' car without permission. The summer found me taking the Saab to Road America and Blackhawk Farms, my two local road-racing circuits, to watch the races and do a little lapping during the lunch break. Susan entered "her Saab" in the autocross competition at the National Saab Owners' Convention and managed a very respectable Fourth in Class with the tires pumped up to 44 PSI.

The Saab also saved me from serious injury on my way to a job interview. I was taking a secondary road early one January morning after being downsized "in order to allow the company to grow and respond at a faster rate" by my previous employer. The morning air was warm, and patches of fog hung in the trees and low-lying areas. Overall, roads were clear, and as I rounded a blind corner I spotted a police cruiser with its lights on. Acting on pure instinct, I braked hard and cut the wheel slightly to the right, as I had no idea how fast the cruiser was moving, and I had to get out of the way. This proved to be my undoing. The rear wheels locked, the back end came around, and I shot toward the ditch at a 45-degree angle.

The driver's side front wheel dug into the snow, and the car flipped violently onto its side before

doing two midair spins and then crashing back down, shiny side up, in the same direction that I had been traveling. I was disoriented for a moment, then I shouldered the door open and climbed out, brushing a mixture of sand, snow and broken glass out of my hair and face. The car was a mess. The left side was dented front to back, the hood was pushed over to the right and the driver's door window had shattered, probably from impact with my head.

The corner had been covered in a layer of black ice. I looked over at the police cruiser, parked in the middle of the road, exhaust curling from the tailpipe. The officer lowered his window a couple of inches and asked if I was okay. I did a quick check and told him, "Just bloody great," as I stood knee-deep snow, wearing my good suit and dress shoes.

The officer shot me a look and said, "I stopped here to slow people down; this corner is really slick and I called for a salt truck to drive down from the county shops." It wasn't until the wrecker arrived and pulled my mangled car out of the ditch that I realized how lucky I had been.

Luck, coupled with a good dose of Swedish engineering and metallurgy, had allowed me to walk away with nothing more than a superficial scratch on one cheek and a few sore muscles. That corner caught another half-dozen cars before the county salt truck arrived and I wondered if any of the other drivers had been able to walk away as easily as I did.

We had the Saab repaired even though the insurance company came within \$200 of totaling it. The owner of the body shop that did the

repairs was a high school classmate of my wife, and he did a fantastic job. The dents were pounded out, new glass was fitted all around and he repainted the whole car in the same stunning platinum blue metallic, but it was never the same as before. The handling could be best described as "twitchy" on ice (due in part to a couple of extra degrees of negative camber in the rear axle) and the whole car had a few extra squeaks and rattles on rough pavement. In the end it was relegated to beater/commuter car status, good enough to take me to work (I got the job, by the way) and good enough for the weekly trip to the dump on Saturdays with the back seats folded down, piled with bags of trash and recyclables. A bad front-wheel bearing and leaking rear calipers finally gave me enough reason to pull the battery and park it next to the garage.

I finished pulling the dashboard, center console and interior panels, and if the weather holds, I will drop the fuel tank before removing the headlights and grille. I have a certain degree of regret, mixed with real sadness that this once great car is now just a shell, picked clean like a skeleton bleaching on the plains of Africa. If I owned a backhoe I would seriously think about digging a big hole behind the garage and burying it, much to the chagrin of my neighbors, and then chiseling a fitting epitaph on the granite marker: "1987 Saab 900S. Part car, part truck, part camper, part race car, and a lifesaver. It really was something better."

*Mike has written for the Milwaukee Saab Club newsletter and is also a past contributor to NINES. He was crew chief for Jerry Sweet, owner of Sweet Motors, who ran a SAAB 99 in the SCCA Pro Rally series.*

## Has Your Saab Embarrassed You Lately?

By Linnea Krajewski

Saabs are unique and quirky cars in every way. They don't look or act like anything else on the road. But, like all cars, they do break. Unlike most cars, they usually don't do it quietly.

A few days ago, Snigel and I were leaving the mall after a successful shopping trip. As we approached an exit, the most god awful racket came up from beneath the floorboards. I slouched lower in the driver's seat in a vain attempt to keep from being noticed. The CHECK ENGINE lamp lit up in the dash, and Snigel's engine died as we rolled up to a stop sign. I consulted the little mechanic in the back of my head, and we agreed that it sounded like the downpipe had failed, most likely just aft of the oxygen sensor. I keyed the engine, and it bellowed back to life, confirming my suspicion. There is probably nothing louder than an unmuffled 9000 in a parking garage with a large group of smirking and gesturing teens standing around. Snigel and I beat a halting, noisy retreat and didn't stop until we had reached ConnTech to have the problem resolved.

That was not the first time I had experienced a creeping desire to become invisible while driving Snigel. Last winter, the baffles in his rear muffler rotted free, blowing back against the opening to the midpipe. Unfortunately, this happened on the Interstate at approximately 75 mph. Every other driver around us was mighty happy to see us drift off the highway, leaving the road open for cars that could travel faster than 30 mph.

Even the lovely Saabrina has caused some mid highway consternation. Nearly four years ago we were headed to Vermont on a warm, sunny July afternoon. In traffic on the Mass Pike I began to notice that the clutch pedal was not returning to its usual position after my foot left its face. We beat a hasty retreat off the Pike at Exit 9; my intention was to double back to a nearby Saab dealer

off Route 20 to see about the errant clutch cable.

Saabrina, bless her gearbox, had other ideas. As we rolled up to the toll gate, her clutch cable snapped, the clutch began to smoke, and she refused to move another inch, while I had a quiet nervous collapse with half of the population in New York and New England stuck behind us.

One day, while at a rest area on the thruway, I returned from the comfort station to find a gorgeous steel grey Viggen coupe parked next to Saabrina. Stopping to chat with the gentleman who owned the car, I was admiring the Viggen with my back to Saabrina, paying her no attention. Her alarm suddenly started to go off as if she were being attacked by Huns. I had to hit the button three times to quiet the noise, and, with an apologetic red face, I gracefully ended my conversation with the Viggen owner.

And then there's Emmy. Emmy had just been returned to health, and I was proudly showing her off to my old friend, David Vincent, the man who was most responsible for bringing Saabrina and me together. I was standing next to Emmy, boasting about how well she ran, when I chanced to notice a river of green issuing from beneath her hood, heading straight for my Reeboks. Continuing the conversation and trying, oh so nonchalantly, to reach in and shut the engine down, a series of loud noises started to come from somewhere about her firewall. I politely (but abruptly) ended my conversation with David to hustle Emmy home to refill her aptly named burp bottle.

I have learned always to search for a funnel with Emmy as a result of a near disaster that occurred while returning from our maiden voyage to Carlisle. I had stopped to refuel and check Emmy's oil at a filling station just off the Taconic State Parkway in New York. Finding the sump to be low, I pulled a quart of oil out of the

boot and carefully unscrewed the oil filler cap. Ol' Deadeye decided against hunting for the suddenly missing funnel, as she never missed the oil filler hole in the valve cover. Except this time. Cool oil splashed all over the hot exhaust manifold. To my complete horror, flames erupted from the hissing oil. Dropping the hood in an attempt to cut off some of the oxygen feeding the fire, I ran into the station and, after some argument with the teen running the counter over his nonexistent fire extinguisher, managed to put out the campfire under the hood with a few hastily thrown handfuls of sand. Surveying the damage, I filled the sump (carefully, now), filled the fuel tank and took off for home. Emmy appeared to be fine until I stepped on the gas to enter the parkway. It sounded like all of the plug wires had decided to go on holiday at different times! Emmy ran alternately on two cylinders, then four, then three, then back to two. Pulling over, I noticed that the wires were badly charred and had several bare spots. I looked at the wires, calculated the amount that a 162-mile tow home would cost, and then figured that I couldn't possibly do any more damage to Emmy than I had already done. By good luck and by the seat of our pants, we somehow managed to make it home under our own power, albeit two hours later than I had planned.

I can't wait to get Astrid and Emma on the road to see what surprises they have in store for me!

*Linnea lives in the wilds of New Hampshire with her Saabs, a 1977 99 Turbo Test Car (Emma), a 1978 Production 99 Turbo (Emmy), a 1980 Classic 900 Turbo 5-Door (Astrid), and a 1995 900 SE Turbo Coupe with 251,690 miles (the lovely Saabrina). Sadly, we note the unfortunate passing of Snigel on January 21, 2005, due to damage suffered in a collision with an Audi. Snigel will live on as a donor to many other 9000s.*



Sports Car Service held their annual Christmas party in December. Photos by Stefan Vapaa.

“Trailer Park Casanova” took this spy photo of the 9-3 SportCombi in the western desert during an advertising photo shoot. The new Saab is set to debut at the Geneva Auto Show in March.



Correction: In the last issue of NINES the photo of George Vapaa’s fleet on page 10, entered in the SOC04 Best Saab Fleet competition, was indeed one of the winners in the Individual/Family Category, but our intention was to show Bill Jacobson’s winning entry in the Business/Corporate Category. In our defense, both George and Bill hail from Wilmington, DE! The above photo shows Bill holding the winning entry. Photo by Tom Nelson.

# Classified Ads

## SAAB CLASSIFIED AD RATES:

Ads offering Saabs or parts for sale, or wanted, are available to members and non-members. Ad rates are for 25 words EXCLUDING your name, telephone number, address, etc. Extra words are charged at \$1.00 per five extra words. Classified ads MUST be prepaid. Ad rates are as follows:

TYPE OF SALE	Members	Non-members
CAR	\$10	\$15
PARTS	\$5	\$7.50
WANTED	\$2	\$3
COMMERCIAL	\$15	\$15

**DEADLINE:** 25<sup>th</sup> of every odd numbered month for inclusion in the next issue.

Mail ads with full payment to:

### SB Productions

Saab Classified Ad  
30 Puritan Drive  
Port Chester, NY 10573

## Autos for Sale

### 2000 Saab 9-3.

Black, manual, 47,300 miles. Price: \$12,500 OBO. Smooth black Florida car. I am the 2nd owner. Original 17" BBS w/Michelin Pilot tires less than 17,000 miles ago. Rims are in very good condition with factory clearcoat. Full factory leather. Saab wooden shift knob and Saab extendable center console installed. Power moonroof. All work done at dealership or local import shop. Full synthetic regular oil change. New A/C controls, new pulleys & alternator installed.

Photo available at The Saab Network Classifieds:

[www.saabnet.com/tsn/class/93.html#050120ntrud](http://www.saabnet.com/tsn/class/93.html#050120ntrud)  
Contact: Nicholas Trudeau, St. Augustine, FL.

Email: [www.saabnet.com/tsn/class/classmail2.php3?tag=050120ntrud](mailto:www.saabnet.com/tsn/class/classmail2.php3?tag=050120ntrud)  
Phone: (904) 642-4388 - Ask for Nicholas regarding Saab for sale.

**1999 9-3 SE Turbo.** Seeking Saab loyalist to continue the care and pleasures of this 5-speed.

Has a unique, limited metallic green-silver color. All the expected bells and whistles including prewired for CD changer, heated seats, cruise, sunroof, etc. One owner, well maintained 77,000 with available Saab service records. New brake pads (2005),

NINES can also place your ad on The Saab Network (Internet classified ad) for you. Include TSN ad rate along with your NINES Classified fee: \$25 for cars, \$15 for parts, \$10 for wanted, for up to 150 words. We can also scan and submit your photograph at no extra cost. Please enclose SASE if you want your photographs returned.

new tires.

Regretfully selling because of permanent leg injury. Best performance since my 1985 Saab, which sold twice after my 247,000 miles.

Pictures available at [saabnet.com](http://saabnet.com).

Contact: Joanne Barnes, Fort Washington, MD (DC Area).

Phone: (301) 248-4716.



### 1998 Saab 900 CSE.

White, manual, 79,631 miles. Price: \$9,650. The Good: original owner, all records, no smoke, 225hp Aero motor, always garaged, 16" Aero wheels, almost new SO3s, new Konis, H & R springs, poly bushes, front strut brace, complete new BSR SS exhaust w/3" downpipe, SaabSavior short shifter. The Bad: clunk at right front on hard bumps where dealer messed up Koni installation, short shifter works well but difficult to adjust for linear shift into fifth -- I have all original parts. The Ugly: cracks in driver seat, small crease on trailing edge of left rear door. Have Thule rack, original springs.

Contact: Michael Hamway, Glen Allen, VA.  
Email: [www.saabnet.com/tsn/class/classmail2.php3?tag=050201mhamw](http://www.saabnet.com/tsn/class/classmail2.php3?tag=050201mhamw)  
Phone: (804) 752-1645.

### 1978 Saab 99 Turbo.

Silver, manual, 60,000 miles. Price: \$2,000. 1978 99 turbp Silver/Red interior, distress sale -- losing garage storage, motor out, heater out, must sell. Mechanical restoration in progress. You transport car with NEW parts: cyl. head, heater core, tires, gaskets/seals/master cyl., more, including factory manuals, tools, Sales, Service Bulletin books. Near zero rust!

Contact: Creighton Demarest, Darien, CT.  
Email: [www.saabnet.com/tsn/class/](http://www.saabnet.com/tsn/class/)

[classmail2.php3?tag=050207cdema](http://classmail2.php3?tag=050207cdema)  
Phone: (203) 943-2538.

### 1971 Saab 96.

Tan, manual, 150,000 miles? Price: \$2,700. Hate to, but must sell my little dream car. It was overhauled not long before I moved out of the country five years ago, at which time I put it in storage. Though sitting has taken its toll, the body is still good, with only a bit of flaking paint around the grille. Interior is good except for tears in the driver's seat and a missing lock on the driver's door. The trunk latch needs adjustment, and one trash bin has pulled from its mount. Needs the TLC of a true Saab-lover. Make an offer!

Photo available at The Saab Network Classifieds:

[www.saabnet.com/tsn/class/9X.html#050123jfish](http://www.saabnet.com/tsn/class/9X.html#050123jfish)  
Contact: Judith Fisher, Marysville, WA.  
E-mail: <http://www.saabnet.com/tsn/class/classmail2.php3?tag=050123jfish>  
Phone: (360) 830-5332.

### 1967 Saab 96.

Blue, manual, 56,000 miles. Price: \$6,500. I am selling one of my favorites. This car has absolutely no rust except for small hole under the battery from acid drips. Has a newly rebuilt Monte Carlo engine with Venolia forged pistons, all-new engine bearings including big ends of the rods. The transmission was overhauled 10,000 miles ago. Monte Carlo dash and gauges with new dash pad. Converted to disk brakes in front with stainless lines on all fours. New KYB shocks, new two-inch exhaust with a GT front muffler.

Photo available at The Saab Network Classifieds:

[www.saabnet.com/tsn/class/9X.html#050207madaa](http://www.saabnet.com/tsn/class/9X.html#050207madaa)  
Contact: Marty Adams, McIntire IA  
Email: <http://www.saabnet.com/tsn/class/classmail2.php3?tag=050207madaa>  
Phone: (888) 722-2246

### 1964 Saab 95.

Tan, manual, 107,000 miles. Price: \$7,500. I have decided to sell one of my pride and joys. This car was owned by the late, great Larry Williams. I have rebuilt the front and rear brakes and overhauled the transmission and the engine. New exhaust, a new recored radiator, and new tires. I drove this car from Meyer to the Saab convention in Denver in 1999 where it placed second in its class (next to Bruce Turk's 95). This car is NOT restored but a very good and presentable ride. It does have some minor rust in nonstructural areas.

Photo available at The Saab Network Classifieds:

www.saabnet.com/tsn/class/  
9X.html#050207madam

Contact: Marty Adams, McIntire IA.

E-mail: www.saabnet.com/tsn/class/  
classmail2.php3?tag=050207madam  
Phone: (888) 722-2246

**Wanted**

**1976 Saab 96 Coupe or SPG.**

Ready to purchase 1970s 96 coupe. Prefer restored but will accept reasonable running project, and an SPG from the 1980s or 1990s. I will come get it.

Contact: Bob Mirabile, Hauppauge, NY.  
Email: www.saabnet.com/tsn/class/  
classmail2.php3?tag=050101bmira  
Phone: (631) 332-0214.

**Parts and Miscellaneous**

**For Sale: 900 Parts.**

1985 - 1993 900 engines, automatic and manual transmissions, some leather seats, two sets of SPG rims. C900 dashboard -- one tiny crack. Hoods, hatches, trunks, doors, convertible glass. Parting out 1990 9000 turbo, solid engine with 100,000 miles on it (turbo removed). Parting out 1987 turbo 900 with 140,000 miles, motor, runs strong. Parting out or selling complete 1992 900 turbo, 175,000 miles with bad manual transmission, nice tan leather, clean car. 1992 900 turbo automatic with 139,000 miles, ran and drove great.

Contact: Christen Szeg, Chelsea, VT.  
E-mail: www.saabnet.com/tsn/class/  
classmail2.php3?tag=050201cszeg  
Phone: (802) 889-9489.

**For Sale: Airflow Kit and Trailer Hitch and More.**

New C900 airflow flare kit, never installed, \$300. C900 trailer hitch, excellent shape, \$50. 1987 900S 16v cyl. head, 200k, complete, \$150. New C900 Hood Protector Strip, \$35. New BBS RK 2-pc. wheel and tire package, with new lugnuts still in blister pack, perfect condition, \$1,750. Early Bolt Pattern C900 SPG wheels, set of 4, no tires. One wheel has slight bend, minimal curbing, can be sanded out before painting, \$150. Early C900 grille, nice condition, all tabs intact, \$50. Late C900 1987 - 1993 bumpers and extensions. Sorry, no turbo chin spoiler! Fresh paint and clearcoat on all, minor flaws in body work but still much nicer than average, \$250.

Please contact me with any questions. Shipping cost is the responsibility of the buyer. Local delivery possible within 75 miles on larger items.

Contact: Jason Morris, Pottstown, PA.

E-mail: www.saabnet.com/tsn/class/  
classmail2.php3?tag=050104jmorr  
Phone: (610) 780-2024.

**For Sale: Saab Club Garments Closeout.**

Cleaning out the old stock of club stuff. Various styles, sizes, colors. Stickers and vinyl graphics. Once they are gone, no more will be produced. Contact me with your ZIP code for shipping quote. Multiple items will be shipped together to save cost. We produced most of the goodies from SOC02. Photo available at The Saab Network Classifieds:

www.saabnet.com/tsn/class/  
parts.html#050118jmorr  
Contact: Jason Morris, Pottstown, PA.  
E-mail: www.saabnet.com/tsn/class/  
classmail2.php3?tag=050118jmorr  
Phone: (610) 780-2024.

**Factory-trained Saab specialist in LA.**

No-charge inspections. No-charge loaner cars. Tech II diagnosis. See our ad on page 2!

Walter Wong, Right Solutions, Inc.  
8577 Venice Blvd.

Los Angeles, CA 90034  
(310) 666-2406

saabtech@pacbell.net

**For Sale: Winter Exhaust Special.**

Overstock exhausts for the 1994 900SE turbo to 2002 9-3. Kits come with all clamps and hanger and gaskets for these models for \$320, that includes shipping in all 48 states. These are Starla exhausts, Swedish made, OEM quality. Also have a 1995 convertible top selling for \$750 plus shipping, plus light grey leather seats for that same model and a trunk lid.

Photo available at The Saab Network Classifieds:

www.saabnet.com/tsn/class/  
parts.html#050126karna  
Contact: Kevin Arnaiz, Williamstown, VT.  
E-mail: www.saabnet.com/tsn/class/  
classmail2.php3?tag=050126karna  
Phone: (802) 476-3815.

**Custom Rebuilding of Windshield Wiper Motors.**

For ANY Saab 95, 96 or Sonett. I have the parts and the test setup to get your wiper motor looking -- and running -- like new. Jack Ashcraft, 2030 Grey Eagle Drive, Medford, OR, 97501.

Phone: (541) 779-0731.

E-mail: jackashcraft@charter.net.



For information about the advantages & benefits of belonging to the premiere Vintage Saab Club of North America; send email to: [sonett1@frontiernet.net](mailto:sonett1@frontiernet.net) or mail: P.O. Box 4362, Manchester, NH 03108

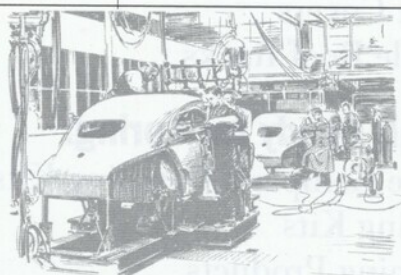

# Vintage Views

Vintage Saab Club of North America



To encourage the maintenance, restoration and preservation of vintage Saabs

The Vintage Saab Club of North America (VSCNA) has but one purpose: to help you enjoy your "2-Digit Swede." VSCNA deals with Saabs through the model "99" only! [vintagesaabclub.org](http://vintagesaabclub.org) is packed full of tips, tricks, how to's, photos, etc., of vintage Saabs. We also have a 28-page newsletter mailed quarterly. Membership is \$22/yr. **JOIN NOW!**



VINTAGE SAAB CLUB OF NORTH AMERICA

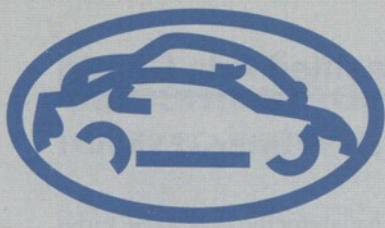

# State of Nine

The Source for Saab Enthusiasts

www.stateofnine.com 877.449.SAAB

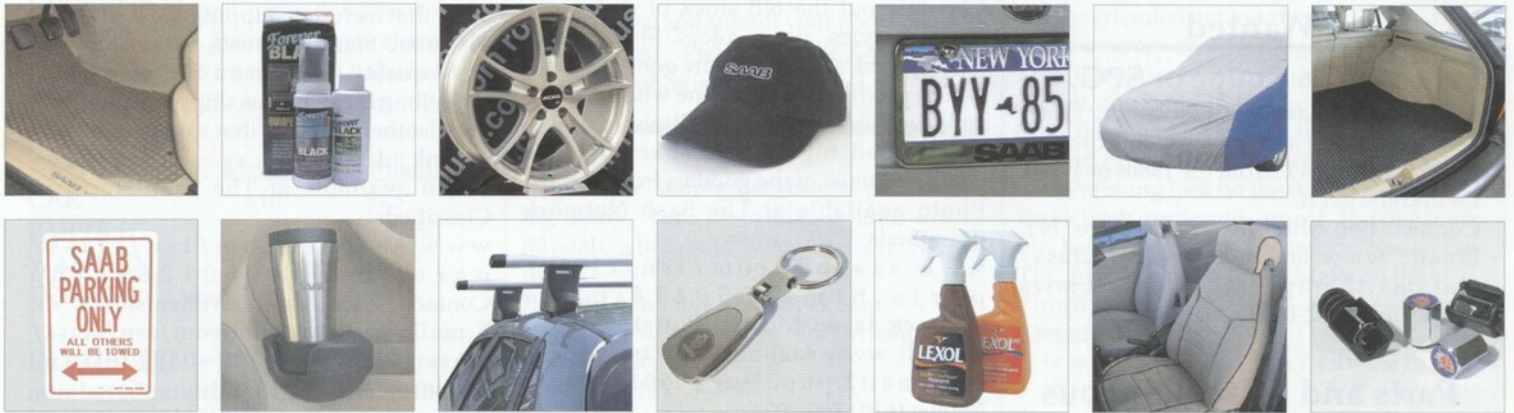

## Welcome to State of Nine, The Source for Saab Enthusiasts

We offer a full selection of products and accessories to fit your Saab, including:

- > Saab OEM Accessories
- > Custom Floor & Trunk Mats
- > Custom Seat Covers
- > Saab & Thule Roof Racks
- > License Plates & Frames
- > Griffin Valve Caps & Key Rings
- > Wood & Carbon Fiber Dash Kits
- > Custom Car Covers

### Get Your Saab Ready for Spring:

- > State of Nine Complete Detailing Kits
- > P21S Cleaning Kits
- > Zymöl Cleaning Products
- > Lexol Leather Products
- > Kleen Wheel Dust Shields

 **Check Out our Complete Line of New & Reconditioned Wheels**

All purchases are tax-free and most ship within 24 hours via FedEx.  
Shop online or over the phone 24/7.

To request our latest catalog featuring tons of great products for your Saab, visit [www.stateofnine.com](http://www.stateofnine.com).

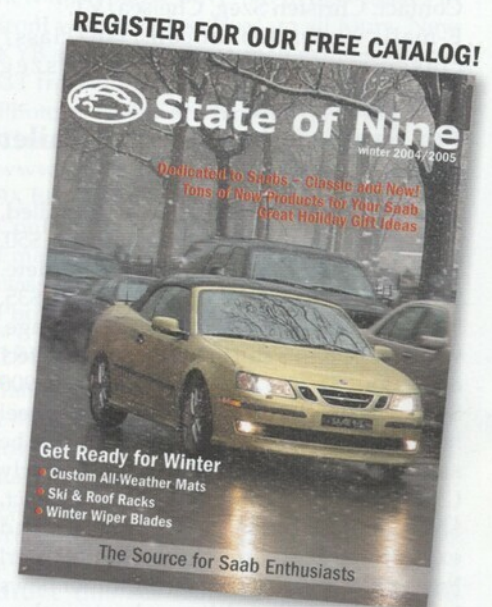

Can't find what you're looking for? Email us for a free product quote at [info@stateofnine.com](mailto:info@stateofnine.com)

[www.stateofnine.com](http://www.stateofnine.com)

877.449.SAAB

[info@stateofnine.com](mailto:info@stateofnine.com)