

#244
March 2000



Nines

The SAAB Club Magazine



W A N T E D



EL BANDITO

DRIVES A SAAB AND HE LOVES IT.

WANTS TO KNOW ALL ABOUT HIS SAAB

SAAB'S HERITAGE

SAAB'S INNOVATIONS PAST AND PRESENT

RECOMMENDED INDEPENDENT MECHANICS

SOURCES FOR PARTS AND ACCESSORIES

SAABS OF THE FUTURE

AND SAABS FROM THE PAST.

BUT EL BANDITO DOES NOT SUBSCRIBE TO NINES

R E W A R D

OF COURSE, MEMBERSHIP IN THE SAAB CLUBS OF AMERICA IS ITS OWN REWARD. BUT FOR ADDED INCENTIVE, ANY MEMBER REFERRING A NEW SUBSCRIBER, SUCH AS OUR BANDITIO FRIEND, WILL RECEIVE A ONE ISSUE EXTENSION TO HIS OR HER MEMBERSHIP.

Fine print: To validate this offer, simply use the subscription form which is on the back page of NINES. The new member encloses a check or money order for the new member rate. The attached mailing label identifies the referring member, and the referring member's expiration issue will be extended by one issue. This offer is limited to one Member Referred New Subscriber per membership form. Now, aren't you glad you saved all your back issues?

#244
March 2000



Nines

The SAAB Club Magazine

2 0 0 0



www.SaabSuperStore.com

Andrews Inc. of Princeton



PHONE: (203) 284-8989
FAX: (203) 269-8842
www.luxurycars.com

IMPORTS UNLIMITED

569 N. COLONY RD.
WALLINGFORD, CT 06492

MICHAEL CARO
President

IMPORTED AND DOMESTIC
AUTOMOBILES





The Oldest SAAB Dealer in Iowa
3rd Generation -
Family Owned & Operated

SAAB

MARTY J. ADAMS
Meyer Garage, Inc.
SAAB Imports

2687 480th Street • McIntire, IA 50455

(515) 737-2239 Fax (515) 737-2601





PLANET SAAAB

COMPLETE SAAB SERVICE
CERTIFIED MASTER TECHNICIAN
FACTORY TRAINED

JAY SITTON
(415) 552-7222
(SAAB)

45 Dore Street
San Francisco, CA 94103
Between 9th & 10th, Off Howard



Since 1912
Quality people dedicated to
Customer Service

SAAB

JOHN SCHOBLOCHER
SAAB Sales Specialist
DAVE TOWELL SAAB

111 W. Market St. Akron, OH 44303
(330) 396-9600
E-mail: Towell1@aol.com www.Towellsaab.com



EUROPEAN

EXCHANGE, INC
Specializing in Transmissions for Fine Imported Automobiles

MERCEDES BENZ • BMW
SAAB • JAGUAR
PORSCHE • AUDI
PEUGEOT • VOLVO, ETC.

Rich Varjan
201 • 489 • 7770

155 Lodi St., Hackensack, NJ 07601

Mark Strohm Jeff Hofslund

FOREIGN AFFAIRS



of Duluth, Inc.

722 E. Ninth St. • Duluth, MN • (218) 722-2246

Tim Brown Kevin Booth

INDEPENDENT
SAAB SPECIALISTS



Full
Service
Auto
Repairs

We want
you and
your car
to be
happy

AUTO SERVICE

http://www.saablitzauto.com (717) 626-5264

Strandberg's Auto

Volvo Specialist
Parts For European Cars - Rebuilders

John & Kevin Strandberg

P.O. Box 430 • 615 Polk • Centuria, WI 54824
800-448-5121 (Nationwide) • 715-646-2388

Overseas Speedometer

1-800-444-0292
512-329-8200
Fax 512-306-0276
www.speedometer.com

Rick Borth, Owner

Cable-Driven & Electronic Units • MB Quartz Clocks

- Audi • BMW • Porsche • Mercedes • Saab
- Volkswagen • Volvo • BMW Motorcycles

Please U.P.S. to: 100 Wallis Drive, Austin, Texas 78746

All Recycled Saab Parts

93B, 95, 96, 99, 900, 9000



East West Auto Parts, Inc
4605 Dawson Road
Tulsa, OK 74115-4102

800-447-2886
or (918) 832-7077
FAX (918) 832-7900
website: www.eastwestautoparts.com

THE MIDWEST'S LARGEST SELECTION OF PREVIOUSLY-ENJOYED SAABS. OVER 20 IN STOCK.

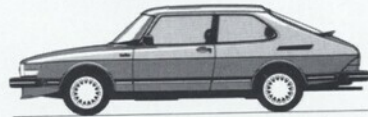

TOM DONNEY MOTORS
FORT DODGE, IOWA
800-626-SAAB
IOWA'S INDEPENDENT SAAB

SALES SERVICE PARTS

Talbot®



Sport Mirrors



Lighting Systems E-code Lights

aardvark international
http://www.cibie.net
562 699-8887 tel. 699-2288 fax
P.O. 509, Whittier, CA 90608

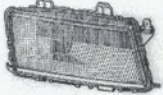

NINES #244, Issued March, 2000,
a publication of the
SAAB Club of North America
2389 Chestnut Hill St. NW
North Canton, OH 44720-5822
Phone: 330-497-0346
9am - 9pm Mon - Fri Eastern Time
Fax: 413-740-5583
email: nines@neo.rr.com
WEB SITE: <http://www.saabclub.com>

NINES Editor & Publisher:
Stephen Goldberger
Membership / Proof Reading (blame her)
Norma Goldberger
Editor Emeritus:
Tim Winker

Contributing editors & photographers:
Chuck Andrews, Jack Ashcraft, Seth Benglesdorf, Phil Lacefield Jr., Bob Sinclair, Bruce Turk, William C. W. Lamb

NINES is published bimonthly by SAAB Club of North America. The SAAB Club is not affiliated with Saab Cars USA, Inc. or Saab Automobile AB.

All material copyright 2000, SAAB Club of North America. Material may not be reproduced without permission. If permission is given, credit must include the author's name and "NINES, the SAAB Club Magazine". The opinions and views expressed in articles are not necessarily those of the SAAB Club and its magazine, NINES.

Editorial contributions are welcome. All material submitted is assumed to be for publication unless clearly labeled otherwise. Machine readable formats are preferred. We cannot answer every inquiry and reserve the right to edit materials submitted. Those wishing to submit material on 3" IBM-formatted disks, please provide ASCII text files (<filename>.TXT), and include a printed hard copy. E-mail submissions should be in the form of an ASCII text file attachment.

Photos: Preferred sizes are 5"x7" or 8"x10". Good contrast color photos or full range black and white can be accommodated, no smaller than 3"x5", please. Photos used on the cover will be rewarded with a one year subscription to NINES and must be submitted in 8"x10" or with the original negative or transparency. For return of photos, include SASE of correct size and postage.

CHANGE OF ADDRESS: Eight weeks notice is required for change of address. PLEASE mail new address and old address, including zip codes, to the SAAB Club at the address above. e-mail OK.

RETURNED CHECKS: There will be a fee of \$20.00 charged for any returned checks.

SUBSCRIPTION RATE is \$30.00 per year in the US. Please see the form on the inside over-cover for complete information.

APPLICATION to Mail at Periodicals Postage Rates is Pending at Canton, Ohio, 44709, and at additional mailing offices.

POSTMASTER: Send address changes to NINES, 2389 Chestnut Hill St. NW, North Canton, OH 44720-5822.

Features

Saab Celebrity Snoop by <i>Heather Henry-O'Connor</i>	16
North American International Auto Show by <i>Stephen Goldberger</i>	20
Saab V4 Parts for Sale a "Cowboy" Poem by <i>Charles H. Stoyer</i>	24
Little Swede Coupe by <i>Tim Winker</i>	28
Resurrection of an SPG (Part 2) by <i>Clifford Quan</i>	32

Saab Clubs

Saab Romp 2000	24
BLÅ RØK Vintage Saab 2000	24
Saab Owners' Convention 2000	25
International Saab Club Meeting 2000	26
North American Saab Clubs and Contacts	27

Departments

Letters to NINES	4
NINES Surveys:	
What Have You Carried in Your Saab	6
What Wild and Crazy Things have you lived to tell about	7
My Saab Saved Me	11
Ramblings and Demands by <i>Phil Lacefield Jr.</i>	
<i>A Mascot for the Masses</i>	12
On the Column by <i>Chip Lamb</i>	
<i>1 1963 96, 1 case of Amsoil 100:1, add fuel = 2000 miles</i>	15
Professional Perspective by <i>Chuck Andrews</i>	
<i>Are You Listening?</i>	17
Spotlight by <i>Chuck Andrews</i>	
<i>Meyer Garage</i>	19
Saab News <i>GM Acquires Full Ownership, Aero Wagon, Sales Data</i>	23
Saab Service Bulletins <i>Two items related to 900 Convertibles</i>	30
ShopTech by <i>Jack Ashcraft</i>	
<i>The V4 Ford Engine - A Short History</i>	36
Rear View by <i>Tim Winker</i>	40
Saab Swap	41
Looking Out (from under NINES) by <i>Stephen Goldberger</i>	42

Front Cover: Saab 9⁵ Aero Wagon photo courtesy of Saab Automobile AB

OverCover: Claude Hutchings of Sauquoit, NY, in his ice racer 900 2-door sedan. Photo by Carol Hutchings.

Subscribers: NINES Issue #245 "Spring Cleaning Swap Special". **Parts for Sale** classified ads will be available to subscribers for just \$2.00 for a 25 word ad, one ad per subscriber, **it MUST be post-marked by 3/25**. Read Charles Stoyer's poem for inspiration, clean out your garages, basements, and attics, and "share the wealth." And **PLEASE** remember to notify NINES well in advance of any address changes.

Letters

In Praise of Vintage Saabs

I notice that my address was changed from the correct form, Madbury, to the incorrect Dover. Madbury is served by the Dover post office but postal regulations permit residents to use their own town name. Probably a computer program thought it was wrong and corrected it into error. Madbury is the correct town.

I hope that the new editorship keeps up the tech articles (Nines was beginning to look like an ad with all those "aren't our new cars so fuzzy and comfy" articles). I prefer a simple easy to fix car with simple parts one can get at local shops, in contrast to those which cost a fortune when a dealer or his flunkies does it. I have noticed that even a lot of those in Saab seem familiar with the new ones and the 93s, but get a blank stare about the good old workhorse 95s and 96s, although they are simple to work on. I like the Real 95s, not the new yuppy 9-5 business which is foolish as none of the potential buyers even know what a real 95 is anyhow, and wouldn't be interested either.

You might remember some of the hints I've contributed to Nines in the past (April 1989, p.8-9; Feb 1990, p.18-19; June 1992, p. 28; Aug 1993 #219 p28; Dec 1995 #228 p22; April 1996 #229 p35; June 1996 #230 p34)

I was amused by Jack Ashcraft's column in Sept 1999 issue. Some years ago when I found the car hard to get going on foggy mornings, I got some end hardware (I'd already inherited from my father the end of a roll of Packard wire), and I got some rubber boots, and made my own plug wires, which worked fine (then I found the spare end hardware that I'd also inherited from my father, after I'd bought more!).

I recall all the fuss made about the heater valves not closing on the old 95-96s. I had this problem once and instead of going to the bother of changing the valve, I figured that it didn't close because the cable wasn't pushed in far enough. But the lever was jammed as far down as it could go. So I got a screwdriver and looked under the dashboard and adjusted the cable housing where it is clamped on, pulled it (I think) using vise grips or something but not to pinch the cable, just a few notches, which had the effect of

pushing the cable in further, in relation to the cable housing, so it closed the valve just fine ever after that. 20 minutes of doodling and no cost at all. I wonder how many people are still changing those heater valves.

Is there a tech site on the internet for drivers of the old Saabs? Maybe I could help out a bit there.

Hope you don't mine renewing even though I'm a bit late.

Dana Morong
Madbury, NH

We value every subscriber and we are always happy to receive renewals.

Our mailing list must be processed through a Postal Service approved process (Coding Accuracy Support System (CASS)-certified address matching software and current USPS Address Information Systems products, to be specific). This process converts your "acceptable" town name of Madbury to the "default" town name of Dover. This will happen every single time. What is really frustrating is when an error creeps into the AIS data base - rare, but it happens.

NINES is not going to abandon its technical articles or the older models. We have two regular columns devoted to the vintage models, and we happily publish tech articles and stories about the older models when we receive them. But, we are also intent on giving coverage to the newer models, activities and adventures by clubs and individuals, and how Saab fits into the GM Corporate Structure.

For the "two-digit Saabs" (models 92 through 99) I recommend the mailing list "VSAAB". Sign-on instructions are available at <http://www.vsaab.com>. -Ed.

In Praise of Newer Saabs

...to be back in a Saab again after three years of old rice burners. We sold our '90 9000T and '94 9000 Super CSE at the end of '96 when we were transferred to northern Japan. Although they would

have been greatly appreciated in that cold & snowy climate, they were just too much for the rural area where we were stationed (not to mention they drive on the wrong side of the road over there and I leave all the fixing to Saab qualified techs - try finding one of those in northern Japan!). So...we suffered....until now.

I picked up my 2000 9⁵ Aero (black) last week in Virginia, slapped plates on it and headed for Florida. Pretty much just loafed along (engine break in, you know) most of the way. No constant speeds, no sticking it to the floor, keep it under 5000 RPM despite the fact that we all know that I could have disregarded all of that and still not hurt the engine at all. I was being a good boy - my Mom was proud. I took the back roads from Hahiri, Georgia, around Tallahassee, through Blountstown and Wewahatchka to Panama City. Behaved there, too....kinda.....I think the folks in Wewa reported a low-flying cruise missile around the time I passed through, but I was at the end of my road trip and wanted to get home to Ma & Pa's house for a home-cooked meal.

My initial observations: Absolutely freaking marvelous! Period. Handles like a dream, comfortable for hours on the road and very slippery through the air. Corners like a cat and will effortlessly do a zoom climb to XXXMPH in an exhilarating short amount of time. Passing on narrow two-lanes with oncoming traffic doesn't require a downshift; hit the gas, point and go. Such a pleasure. Well worth the painful years of being Saab-less. Wonderful stereo, climate control, etc. I can't find anything that I don't like about the car with the exception of no place to install my electronic suite (the older model 9000's had plenty of extra room in the center console); that's minor, though. I managed anyway.

I do miss the old style Aero seats, though. I'm safely past the engine break-in period now. Installed my Valentine One, Beartracker 2 police scanner and a CB radio today (hey - gotta have it); I believe in a reasonable and prudent speed. I'll be motoring back up to Virginia the first week of January (pending the end of the world...man, I'll really be annoyed if THAT happens) to pick up my wife's 2000 Aero (silver) and drop mine off for mudflap/spoiler installation. I'll wire hers

the same way and stress test it to Asheville, North Carolina, to visit friends. Any excuse to get her car on the road and break it in prior to her arrival. She'll be pleased; I know I certainly am one happy puppy. I deleted the DRL (hate 'em) and "brake check" light. Next will be the push-the-clutch-all-the-way-in-before-it'll-start feature. I took the "Saab" and "95" markings off the trunk (you never know when someone will phone in a "VW" or an "Audi" to the police for driving at a reasonable & prudent speed). The only problem/glitch noted so far: cruise control occasionally (twice so far) wouldn't re-engage until I tapped the brake once. I will have to keep an eye on that, but I'm not too concerned.

The car's a head-turner. I particularly like the standard wheels. Makes it look very aggressive - very scary - like something you'd see in an "Terminator" movie that'll come alive and chase you down. I've received many positive comments from everyone that's seen it. Bought 'em both through Military IDS - not a bad deal. I had a couple of minor difficulties (no seat heaters - I had been operating off a Canadian delivery option/standard equipment listing provided by the IDS rep that conveniently didn't have "CANADA" written across the top) but Saab came through and installed them for us. I'm happy now. Ecstatic. Completely comfortable and at ease behind the wheel; it's nice to be home again with an old friend....and I'm not talking about Florida!

I did make another observation in the back of the owners manual where they break down the VIN. The fifth position indicates: D = 9-5 w/driver & passenger airbags; F = 9-5 SE w/driver & passenger airbags; H = 9-5 Aero w/driver & passenger airbags; M = 9-5 GRIFFIN (!?!?!?) w/driver & passenger airbags. A glimpse of better things to come? I hope not.....I don't wanna have to sell these for two Griffins!

So, log us in to your Saab owner database.

*Ted & Barbara Carwile
Panama City, FL (until we find
a place to live in Maryland)*

*The 95 "Griffin" is full luxury V-6
model which is sold in other markets. It*

contains equipment which is optional on "SE" models in some markets but standard on USA "SE" models, such as the electrochromic self-dimming rear view mirror, other equipment optional on SE models like a CD changer, and equipment which is not available at all in the USA, such as an ultrasonic parking aid. - Ed.

My initial thought after reading James Maugham's "floating away" article in NINES #243 was "YOU MEAN SHE STILL MARRIED HIM?!! What a woman!

*Richard T. McSherry
Norway, ME*

In addition to the vintage SAABs I listed on the renewal form, I was lucky enough to purchase a 1999 93 VIGGEN in October. The event occurred unexpectedly when I was having routine warranty service performed on its predecessor, a 1997 900SE coupe (concourse winner in '98 and '99). So far the VIGGEN has exceeded all my expectations; winter has not stopped me from enjoying it either. I installed a set of Bridgestone Blizzak MZ-01 ice tires mounted on 16x6.5 viking shield alloys and have not had any problems driving in the snow. Handling has not been greatly affected and the tires are relatively quiet and stable on dry pavement as well.

*Bruce Billing
Cape Neddick, ME*

Wasn't sure I'd renew, but then my want-ad located a 95 in reasonably good condition that can be made operable using parts from my two rusted out 95s. Now I own it but need to have it hauled from western Colorado! Any suggestions?

*George Tiers
St. Paul, MN
gtiers@aol.com*

As you predicted, when I got back to Atlanta from the Detroit show, the January issue of Nines was waiting for me. Great issue!

In particular, I wanted to comment on the article comparing the new 9-5 wagon to the 9000 hatchback. The comparison was very fair, and really highlights what we tried to accomplish with the wagon - which was to advance the state of the art for a stylish, broadly appealing, utilitarian Saab that is still efficient, fun to drive and just as refined as the sedan. And of course, we want to carve out a place for Saab in the trend-setting premium wagon segment. I was also gratified by your appreciation for the many detail features and concepts built into the car -from the tailgate hinge concept, to the trim details, cargo tracks, exterior illumination, sliding load floor, etc. You didn't miss a thing. As the original program manager for the wagon, I can tell you it was a hard fight to make sure they all made it through the development process.

You also pointed out a key element of our strategy for the wagon (and the 9-5 generally), which is to offer all the improvements and advantages of the 9-5 in a wagon version—with no price premium over the sedan—creating a very high value offering for our customers. As you pointed out, the value is striking, particularly compared to the earlier Saab 9000. And if you liked the way your test car drove, wait until you try the just-announced Aero version! It's every bit as great as the sedan that Road & Track just rated higher than the S80 T6 - and it will still take your daughter and all her stuff to college!

But just so you (and your readers) don't think I'm completely one-sided in my views, I'm excited to report the addition of one of my all time favorite cars - a 1995 9000 Aero - to our family fleet. This will allow us to better preserve and enjoy my wife's 45,000 mile SPG that has been serving as her daily driver. Now if I could just figure out how to expand the garage...

*Dan Chasins
President
SCUSA*

What have you carried in Your SAAB?

What have we packed and carried in our Saab? We own an RV park and also do painting and building maintenance. We use my Saab 900 Turbo to haul everything. I've loaded enough 8-foot long 2x4s to make a half-dozen picnic tables in the back of my "Swedish pickup" and still gotten the hatch closed. The back end will easily swallow up at least a dozen gallons of paint and all the brushes, rollers, and everything else needed to do the job; with the ladder, mop and broom on the car-top carrier. Recently we moved to a new house-sitting job and loaded my king-sized waterbed in and on the car, along with all the necessary pillows and bedding.

In fact, the only thing I really had trouble with was the moose antlers. As I recall, the back end was full of buckets and other dam-digging supplies as well as my clean laundry and a full-sized spare tire, so I put the antlers in the back seat. It took my husband and I quite a while to wrestle them back out of the car without tearing up the headliner. Needless to say I was warned not to do that again.

I had 5-point seat belts installed with a harness bar mounted behind the back seat. Sometimes that presents a challenge, but the bar is removable, and I haven't had to take it out yet. In fact, if I could

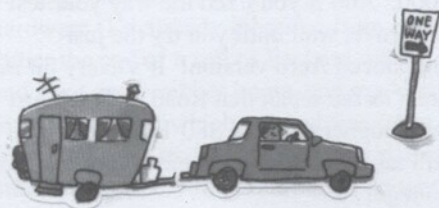

figure out how to carry a load of sand and gravel I'd prove to my husband once and for all that he doesn't really need a new pickup truck!!

My Saab has taken us from Washington to Wyoming to Minnesota to the Northwest Territories in all seasons. We've rallied it loaded to the gunwales, we've driven it on roads (from the tundra to the desert) that would terrify most SUV owners. She's got over 140000 miles on her and still does everything I ask of her. We're on the staff of this Winter's Alcan

5000 Rally and we haven't decided which car to take. I may be sending you a picture of her taken in Prudhoe Bay in the next couple months.

*Cristy Breazeale
Kenai, AK*

We have owned SAABs for 26 years so we are well acquainted with the amount of cargo they can carry. So when our son called and asked us if we could pick up a Pooh Bear, we said "Sure!!" Turns out that this bear was a rare store display model (ca. 1976) and was a BIG bear!

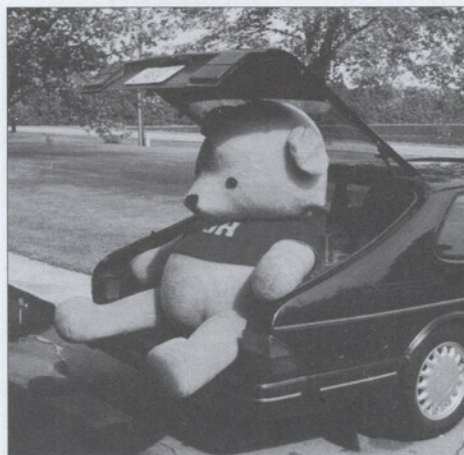

After some work we got him in our 3-dr 92 900S and closed the hatch. The 4-hour trip was accomplished with Pooh's feet on either side of the driver's head.

*Elroy W Kauffman
Harrisonburg VA*

Enclosed please find my renewal for another year of fine SAAB reading. The editorial transition seems to be pretty smooth. Congratulations!!

In response to a note in the November (#242) issue about loading stuff in a SAAB, enclosed please find photographs of my wife's and my experience with loading up our '84 900 Turbo to maximum capacity!

Here's our story. We met in 1991 as new MBA students at SUNY-Albany, in upstate NY. By the time May 1993 graduation rolled around, we had decided to get married. Neither of us had any particular job prospects in mind, and we had both spent all our lives in various parts of NY State. So we decided to pack-

up and take-off to find our destiny, on a journey of exploration.

These pictures document our two-month trek around the US, searching for a cool place to call home. We packed everything we thought we would need to live out of our SAAB, as well as to be able to set up a life and find jobs in wherever we finally landed. We packed our camping gear, enough quantity and variety of clothes, food & water, both of our bicycles, job hunting stuff (resumes, contacts, stationery), tools and a few spare parts, music, books, and even beach chairs. It's been over six years so I'm sure I forgotten many more items. Needless to say, there was just enough room for the two of us in the front seats, and a small tunnel through all the stuff to allow for



seeing through the rear-view mirror.

Eight thousand or so miles later, we wound up in the beautiful Central Coast of California, in a little beach town called Monterey. Much to our surprise, we weren't run out of town by the authorities, and we actually managed to find some gainful employment.

Many things have changed since we settled here on The Left Coast. By some stroke of luck, we actually became California homeowners a couple of years ago. We bought a new Nissan for my wife. A cat has adopted us. But we've still got our faithful, reliable SAAB with about 175K miles on it. If I start feeling really wealthy, I may just spring for a new 9³ next time the great lease deals from SAAB come around.

Many thanks to NINES and to all who have written in with tech tips, stories and other suggestions over the years (I think I've been a member for 15 years ??). I just wanted to make my contribution.

*Bart von Zastrow
Monterey, CA*

After reading Phil's piece in the last NINES, I decided to tell my most embarrassing SAAB STORY.

My first SAAB was a 72 99, the one with the Triumph engine. After driving it for many thousand miles with a leaky head gasket, I decided to do the right thing and change the offending gasket. Actually I was at the point of having to stop for fill up of water and check the gas.

Getting the head off past the corroded studs was a trick, the local machine shop got the crowbar marks out, when they milled the head a little, and the cylinders where the leak was were so clean. I was impressed with the bracket that held the chain in tension so the engine didn't have to come out for a head removal.

My first mistake was to decide to do the clutch while the head was off, I realized that as soon as I turned the flywheel to get the lower bolts and the chain went limp. I finished the clutch replacement, put the head back on and then proceeded to pull the engine/transmission to reset the chain tensioner.

I was so proud of myself of getting the job done in a weekend and having the

car start on the first few tries. After about two days of driving a loud clunking sound started in the drive train, reviewing the engine removal/replacement section, I realized that I didn't change the lube for the inner CV joints. When the clunking was too bad to drive I pulled off the road and jacked the front end up and grabbed the wheel and sure enough there was lots of back and forth play. I called the tow truck and had them drag it to the local shop, who had bailed me out in the past.

They were "just too busy" to look at it till the middle of next week, so I waited to the middle of next week to get the bad news, called them up and they said it was all ready, come and get it. When I got there the head mechanic said "so you're the guy who pulled the engine, and had the clunking sound?" "yes, I was, I said," and asked them what was the problem, the mechanic replied in a loud voice "You forgot to tighten the lug nuts!" It was then that I noticed all the people in the room had put their tools down and were staring at me.

*Tom Kinnaman
Cincinnati, OH*

**800-270-SAAB, Parts
724-238-0900, Parts
724-238-0099, Fax**

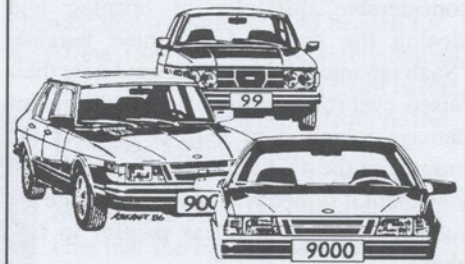

DENNIS SWEENEY
ROAD TESTED SAAB PARTS
334 Wilpen Road
Ligonier, PA 15658

Late model Road Tested
900s and 9000s for sale.

**Rebuilt transmissions, 900 and
9000, manual and automatic**

Used mechanical and electrical parts,
interiors, accessories, sheet metal, rebuilt
steering racks, wheels, heads.

Same day shipping on most items.

WHEELS WHEELS WHEELS WHEELS WHEELS WHEELS SPORTS CAR SERVICE

NEW IN BOX

SAAB #46-47-475 SUPER CS
THIS 8 SPOKE WHEEL WILL
MAKE YOUR 88- 900 OR 9000

LOOK SUPER !!! 6"X15"
ONLY \$500.00 SET OF 4
INCLUDES \$11.00 CENTER CAP N/C



SAAB #02-42-412 5 SPOKE
THIS 7" WIDE WHEEL IS THE
PERFECT ACCESSORY FOR
YOUR 9000 ALSO FITS MOST
88- 900 EASY TO CLEAN & MAINTAIN
ONLY \$600.00 SET OF 4
7"X15" INCLUDES CENTER CAP



**1-800-SAAB-130
FAX 302-764-7454
WWW.SPORTSCARSERVICE.COM**

"TAKE OFFS"

SET OF 4
6.5"X16"
5-BOLT



5 SPOKE #46-87-257 3 SPOKE #45-66-055
\$600.00 \$500.00

ALSO AVAILABLE MICHELIN MXV4
215/55/VR16 "TAKE OFFS" \$110.00 ea.
MOUNTED AND BALANCED ON ABOVE-N/C

EXH SYSTEMS FOR 94- 900 & 9-3
SPORT EXH ONLY \$325.00

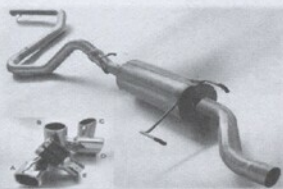

"TAKE OFF" \$140.00 CENTER
\$140.00 REAR

BUY BOTH FOR ONLY \$230.00

"TAKE OFF" HAS LESS THAN 5 MILES

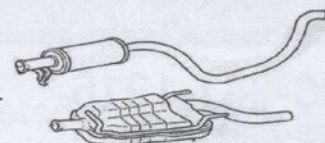

WHEELS WHEELS WHEELS WHEELS WHEELS WHEELS

Wild and Crazy

A Lesson Learned in Transporting Old Saabs

"So, what happened to your truck?" my friends ask me as they notice my considerable difficulty in opening and closing the bowed and dented tailgate. "Saab ran into it," I respond, but I note their raised eyebrows as they survey the major damage which is at least 3 feet off the ground on the 4X4 Nissan pickup. "I'll tell you about it someday," I say as I change the subject to something less painful to talk about.

Well, the time has come to reveal what really happened on that fateful day in early August as I getting ready to haul yet another load of Convention stuff to Keystone. As Convention Chairman for Colorado 99 I ended up with all the check-in materials, T-shirts, and miscellaneous items that needed to be transported to the Keystone Resort approximately 60 miles from my home in Evergreen, Colorado so I was making daily trips with my truck in the days leading to the Convention.

But first, to properly set the stage for the events to follow, I need to tell you about Gunhilda, our original 1966 MC850

that my youngest daughter Erika acquired while in high school back in 1986. This car is a twin to the MC850 that Neil Plucknett drove on "Nines Run the Rockies." (See "High Altitude Driving: Learning the Hard Way" NINES #242) After 13 years of just sitting in the yard with little done except having Bud Clark rebuild the crank and freshen up the two-stroke motor, 1999 seemed like the time to start some serious restoration.

Coincidentally, Jerry Danner's new (Mile Hi - Ed.) body shop was about ready to re-open for business at his Lipan Street location in Denver, so I arranged for Gunhilda to be the first car to be painted in the new shop. After two weeks of body work and three coats of original Saab white paint the car was beautiful, and ready to reassemble in early July. I reinstalled the fenders with new body welting, lovingly polished and reinstalled all the chrome bits and bumpers, even put on the Marchal driving lights that had been boxed up for special protection for a decade. Needless to say, this car was looking good enough to take to Keystone for display at the Convention. You should

be getting a clue at this point that this is the Saab that became involved in the damage to my truck.

Gunhilda had not yet been properly prepared mechanically, so I didn't want to drive her onto my 16-foot tandem-axle trailer. A friend had offered to help load her that coming evening but I was impatient to get another load to Keystone so I decided, "hey, I can just winch her onto the trailer by myself"

I hooked the trailer to my pickup and parked it just below the crest of a small hill so that the two loading ramps would not be very steep, and the trailer would be fairly level. As an extra precaution I put a heavy 8-foot landscaping timber across the trailer to block the front wheels and stop the car as it came up onto the trailer. I then proceeded to crank the hand winch with the car easily rolling up the ramps. "Hey, this is working great," I thought to myself, as the front wheels came off the ramps and up onto the trailer bed, then, a sudden "oh s___," as the cable suddenly went slack, As the wheels contacted the timber and started sliding it toward the front of the trailer, my very first

900 - 9000 - 9³ - 9⁵



English - Swedish Car Spares Ltd.
345 Branch Drive SW - Alpharetta, GA 30004
-Largest collection of Recycled Saab parts in the South

1-800-241-1916

770-475-2662 Local

770-475-2663 Fax

<http://www.english-swedish.com>

Visa - M/C

Disc - Amex

COD

UPS - Motor Freight

New Arrivals Daily

Fair Pricing

Call for Quotes

Now carrying Volvo parts, too

inclination was to throw all my body weight against the hood and grille of Gunhilda in an attempt to stop her from running into the rail at the front of the trailer. Common sense and self-preservation fortunately prevailed however, as I jumped off the side of the trailer as the car went rolling past me, gaining momentum on what now was obviously a downhill run. When the landscaping timber abruptly stopped upon hitting the trailer's front rail. Gunhilda's front wheels ran up over the timber and jumped the tubular rail. This startling event was immediately followed by the crunch of deforming sheet metal. I couldn't bear to look as I picked myself up from where I had landed in the grass. The car in which I had invested so much was certainly a wreck, but I couldn't tell how bad the damage might be because Gunhilda's nose was deeply buried in the truck's tailgate.

What to do? I recovered the winch and tangled cable from beneath the old Saab's body which was now resting on the trailer rail as the front wheels dangled

freely over the trailer's tongue. Hooking the winch to the rear of the car and alternating jacking up the car body, then winching, then jacking, I was able to work the tires back over the rail and onto the trailer bed far enough that I could examine the damage. The truck's tailgate was



"Gunhilda" on the trailer and on the way to the 1999 Saab Owners Convention

bowed in by at least a foot, but the visible damage to Gunhilda was almost unbelievable! A bit of red truck paint on one bumper guard!

I now wish I had snapped some photos of the event before I extracted

Gunhilda, but I was too distraught to think of anything except getting the car safely back on the trailer. I removed the tailgate from the Nissan, sledge-hammered it back to somewhat fit the hinges and latches, chained down Gunhilda, and headed for Keystone. (See photo of the safely loaded car.) I rubbed off the red paint before putting her on display in front of the Keystone Mountain House, and I doubt that anyone who looked her over during the Convention had any clue that she had just survived a violent front end collision.

So what's the lesson here? I will never again winch a free-rolling car where there is any chance of it heading even slightly downhill. But you all knew that already, right? I just had to get the car loaded immediately, in spite of the potential danger involved, and I was very lucky that I didn't personally end up as the middle part of a Saab/Nissan sandwich. Anyone know where I can find a good used red Nissan SE V6 (Hardbody) tailgate?

*Tom Nelson
Evergreen, CO*

Garry Small Saab

Saab Exclusive for over 10 years!

800-920-7222

Garry Small Saab has been ranked number one in customer service and sales satisfaction by J. D. Powers and Associates.



We have Nokian Street and Snow tires including the new Hakka 1 snow tire

Fast friendly expert service.
Non-inflated part prices.

Extensive Saab Inventory

800-920-SAAB

**Business hours: 8:00 AM
to 5:30 PM PST**

All major credit cards accepted

www.saabstory.com

Shop Manual for Saabs

Saab 900 8 valve 1981- 88 Bentley
Saab 900 16 valve 1985-93 Bentley
Saab 9000 1986-95 Haynes



How I almost got arrested because of my Saab habit.

On Saturday January 8th, 2000, the evening twilight was beautiful here in Minnesota. The sun had just set, the clouds were illuminated with a pink/orange hue, and the warm fuzzy light was reflecting off of the snow. I had just washed the SPG and decided it would be the perfect time to snap a few photos (you know, for the photo contest at the national convention).

About two blocks from my house there is a city park with an outdoor ice rink. The stadium style lights were on and I thought it would make a nice background for the photos. I parked the car on the side of the road in front of the ice rink and walked across the street to take the pictures. There were two people ice skating in the background, which I didn't think much about at the time.

I took five or six pictures of the SPG from different angles. I had to wait for traffic between each picture so it took about 5 minutes to snap all of the shots. After I was done I jumped in the car and drove the two blocks home. My wife and I were going out for the evening so about ten minutes later we both got back in the SPG and took off.

As we drove down the street a cop passed me going the other direction. Two blocks later I noticed the cop had turned around and was coming up behind me with his lights flashing. I thought he must be on his way to an emergency so I pulled to the side of the road to let him by, but instead of passing me he pulled up behind me. I thought this was odd since I definitely had not broken any traffic laws in the four blocks since I left the house.

My wife sitting next to me said in dismay, "What did you do?" I answered truthfully that I had no idea. I rolled down my window as the cop approached.

"Didn't you know that I was pursuing you," the officer asked?

"Um, no," I said.

"Well, do you know why I pulled you over," he continued?

"No," I said again (this is the first

time I had ever answered that question truthfully to an officer but we won't get into that).

He continued, "Why were you at the park taking pictures of two ladies ice skating"?

I tried to withhold my laughter and told the officer that I was simply taking advantage of the sunset and snapped a few photos of my car. He laughed and said that the two lady ice skaters thought I was taking pictures of them and had called 911. He thanked me, walked back to his car, and drove off.

No, the story doesn't end there. My wife was dismayed at the turn of events and it was the topic of our discussion for the duration of our 45-minute journey. The up-shot is that my wife thinks I am a nut-ball for taking pictures of my car. Maybe I am, but I'm sure other like-minded Saab nuts will understand.

Chad Payne
Mounds View, MN
SaabTurbo@aol.com



SPG in the foreground, with skater behind. Norma said, "She's not wearing a tiny skirt, why would she care?"

When my husband says "Saab habit", believe me he's not kidding. Some days I think it's more of an obsession. But you know, my husband asks for very little so if this is what makes him happy so be it. It wasn't until Saturday night, however, that I realized there are some things I just will never understand about his love of Saabs.

If you're a Saab widow as I am - you are forever driving through car lots looking for the perfect deal. Everything your husband/significant other talks about

is somehow Saab related and friends joke with you about Saabs in an effort to figure him out. Does he really love Saabs? Driving down the highway you will pull next to other drivers in Saabs and wave....the scariest thing is they wave back! These are all classic tell tale signs that you are a Saab widow. My girlfriends shook their heads in dismay at our latest story.

Remember, I knew nothing about taking any photos of the car. I was in my bathroom getting ready to leave for dinner when he was furiously looking for the camera and film. I helped him find it, in the drawer where it's always kept, and he announced he'd be right back and left. Had he told me about it, I'm sure I wouldn't have thought anything about it - shrugged my shoulders and gone back to what I was doing. So we leave in our car about 15 minutes later and all of a sudden a cop is behind us with his lights on. Dumbfounded, I asked what he had done. He didn't know but I was afraid he'd been speeding. (In the Saab sometimes something comes over him and he needs to speed). The cop comes to the window:

"Were you at the park taking pictures of a woman and her daughter ice skating?" I swear my jaw dropped. What on earth was he talking about? Then it hit me - so that's what he needed the camera for. Saab photos now - at the park 500 feet from our house?? What on earth for? Why the SPG and not the Red 9000 at least?

The officer left and my husband drove off as if nothing had happened. I turned to him and asked him to explain. The lengthy conversation that ensued was me trying to get **all** of the facts from him: where the car was when he was taking photos, how long he'd been there, etc.? It was like a mother trying to get their five year old to explain why the teacher had called. The facts came out with continued questioning.

I guess to describe my reaction, I was shocked. It was stupid really that we'd been pulled over, a voyeur of women skating he is not. He won't even watch *professional* ice-skating with me let

alone a woman and her daughter at our local ice rink. Taking the photos 5 minutes before we were to leave seemed ridiculous to me. It wasn't until just last night I found out there is a photo contest at the Saab Convention - now the pieces finally fit into place 5 days later, and 30 conversations of dismay.

I probably said "nutball" - I truly don't understand having hundreds of pictures of Saabs. But as I said in the beginning, this is his thing and it does make him happy. I'll continue my role as Saab widow - but he has promised I would be with him the next time we need photos of the Saab so that the police don't need to be involved. The moral of the story - I haven't a clue. Don't take photos of women ice-skating - it's probably a good rule of thumb.

Oh, and I do draw the line. We will not be naming our first-born "Aero" or "Viggen"!

*Traci Payne
Moundsview, MN*

It gave up it's life protecting me from a semi.

There's nothing quite as disturbing as seeing a semi-tractor (no trailer) coming down a hill at you, doing 360s. Especially when it's a few feet away and you have the green. Unless it's that bump, crunch, crunch, bump sound, and the realization that you can can't breathe without incredible pain.

But my SAAB saved me. The ends of the frame rails tore the driver's door handle off and bent in the top of the door. If I had been driving a Honda Civic, I'd be dead. Thank you, my SPG.

After they total it, I'm buying back it for the engine and transmission, the leather, and, of course, the Aero panels. If they don't give me enough to buy a real SPG, I'll make one.

*Rich Sherman
Atlanta, GA*



SAAB CONVERTIBLE TOP PARTS

Top Cylinder
\$120

Motor Pump
\$199

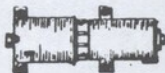

Hold Down tension cables	\$29/pr
1987-94 Stayfast Canvas Tops	
with heated glass window	\$499
1987-94 Headline, black	\$149
1995 Stayfast Canvas Tops	
without glass	\$1150
1996-98 Stayfast Canvas Tops	
without glass	\$1000
Car Covers, universal fit	
Indoor/light weather	\$52.95
Moderate weather	\$78.95
Evolution 4, all season coverage	\$134.95

HYDRO-E-LECTRIC

Unit 8, 5475 Williamsburg Dr.
Punta Gorda, FL 33982

Call Toll-free 800-343-4261

Tech Help: 941-639-0437

Fax: 941-639-0376

America's Convertible Headquarters

THE SWEDISH SOLUTION, INC.

**Servicing SAAB
Since 1982**

Buy Parts From Us... Why? Better Value, Better Service, & We've Got-Em !

- ◆ Most Orders Shipped Same day (on in stock items)
- ◆ Experienced Parts Specialists
- ◆ Lifetime Muffler / Starter / Alternator / Steering rack Warranty Available
- ◆ Over 6,000 different part numbers in stock for SAAB 900, 9000, 9.3 and 9.5 series

- ◆ New & Remanufactured Parts Available
- ◆ Tried and Tested Parts
- ◆ NINES Member Discounts
- ◆ If we don't have it, we will get it for you
- ◆ We install everything we sell, so we know what works. Call us for all your parts needs

Call Now - For Quotes

Toll Free 1-888-669-PART or (7278) Fax (440) 248-0288

THE SWEDISH SOLUTION, INC.
27999 Miles Rd. • Orange Village, Ohio 44022

VISA / MC / Discover / AMEX

E-Mail swedish@bright.net

<http://www.swedishsolution.com>

Ramblings And Demands

by Phil Lacefield Jr.

A Mascot for the Masses

It all started out innocently enough. Yet another night spent in front of this very monitor, surfing the endless pages of Ebay for all things Saab related, as I do pretty much nightly (*see last issue's R&D for more details - ed.*) Keyword searches on "saab" can sometimes bring up totally unrelated hits (items from the now-defunct sci-fi TV show *Space: Above And Beyond* are common), but this night the powerful search engines ground to a halt on the strangest item I'd ever seen listed for sale there. As I began to read the item's description (looking for whatever strange Saab reference had drawn the attention of the search engines, fickle as they may be), I realized that THIS would be no ordinary Saab collectible. The description read as follows:

"In a strictly technical sense, somebody really knew what they were doing when they made this thing. It's built of 3/4" thick pieces of clear pine glued & screwed rock solid - definitely not from Ikea. Measures 17" from tip to tip, a foot across the bottom and 13" total height. Handy cheese bell, wool winder, hose reel, or one of those things you tie boats to. Makes a great counter for really boring board games. Traps large crawling insects while you get your husband and can both demarcate and conceal pet do-do for days while you argue whose turn it is to clean up, without actually losing track of where it was. Then later, you can use it upside down to grow shiatsu mushrooms. Hell, glue it to the roof of your Saab and drive round and round Ford HQ with it. Alternatively, attach to the roof of your VW and invade Poland. Fits over really big earphones for discreetly listening to Wagner all day and an indispensable training aid for the Minoan Olympics. Or for a real blast, try wearing it down to the zoo, get up in front of the Cape buffalo enclosure, breathe loudly through your nose and start pawing the ground with your feet (results may vary; seller not responsible for incidental injuries.) ..."

The item you see pictured here is the very same Viking helmet described above. It drew me, like a moth to a flame, calling out to a previously unknown pocket of kitsch I had concealed in my soul. It simply demanded to be liberated from its captors in the Great White North, but the bidding was fierce and intense. Many other hardy souls had discovered it as well, and the bidding frenzy that had ensued was not for the meek to witness. Determined to see this ungodly beast of a thing put to use, I jumped on the Turbo! and VSAAB email lists and sent out an urgent plea:

"...you may remember me from such Saab favorites as my biting humor and

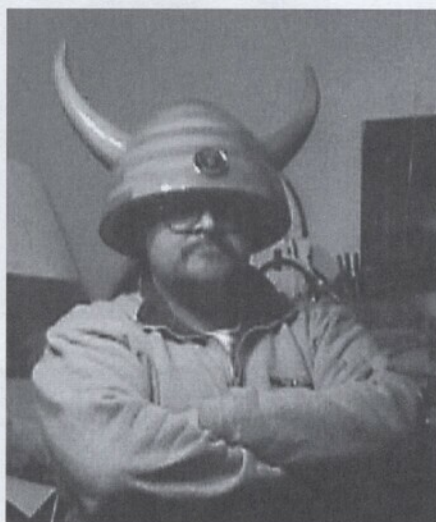

political commentary in recent NINES issues, as well as my continuing lack of good taste and weird humor on these very mailing lists. My purpose here before you today is simple: money. Give me lots of it, and quickly. You see, while there may well be children starving in Africa and human rights violations in China, there exists in this world today something so bizarre, so powerful, so utterly weird, that it simply MUST be owned by our collective online email groups as a memento of our beloved marque. ... I'm sure you will agree with me that this Big Friggin' Helmet (or BFH, as it shall be known) must not fall into the wrong hands, namely those loathsome Volvoites, under any circumstances. We as a united brotherhood of online Saab freaks must rescue this treasure from the oppressive grasp of its current evil Canadian captor and free it to the Saab collective as a symbol, nay, as THE symbol of our pooled insanity. This object,

once firmly in our possession, must forever be emblazoned with a Saab logo on the front and be brought forthwith to each and every Saab Owners Convention, local Saab Club gathering, Saab Romp, SaabToberfest, Saab dealership opening, Saab bake sale and any and all other gatherings which we hold so dear. Great toasts must be drank over its inky maw, tales must be told of its harrowing journeys across this planet, and our descendants must forever know that it was WE who made such a thing possible...Uncle Bob needs a new hat to look silly in after one too many Single Malt Scotch Tasting Parties, and this is just the ticket....So who's with me here, people? Who's not afraid to stand up and be able to say the YOU were a member of the Big Friggin' Helmet Liberation Expedition (t-shirts pending)...."

The replies were swift and sure, and within days I had procured enough funds to release the BFH from its bonds of captivity, as well as a sufficient surplus to construct a velvet-lined carrying case for its upcoming journeys around the globe. The frenzied bidding war continued, during which several times I was ousted as top bidder, but by the time the dust settled at the end of the week I was the only one left standing. The BFH was ours.

Turns out Kathy Randall, the nice lady who sold it, is a courier driver all over Ontario who happened across it in a small curio shop in the wilds north of Toronto, but it gave up no clues as to its original intent, manufacturer or origins. Our worldwide BFH Rescue Drive gave her hours of enjoyment, and she was quite pleased to know it would soon be traveling the world putting smiles on young and old alike.

Which it can be, starting now, if you desire. Having a club event? Scenic drive? Tech session? Shop open house? Regional convention? The BFH is now available for bookings anywhere in the US and Canada, overseas if you're willing to pay for shipping and any applicable tariffs. All I ask is that you sticker the box suitably with national or local pride and ship it back when you're done, so others can partake of the fun. If you're interested, drop me an email at phil@lacefield.com and it's yours for the asking.

Once again another sign that myself and several dozen nuts just like me desperately need to get a life.

800-428-8211
 LOCAL FAX 206-784-5696
 OR FAX 800-447-6740

CARTER

SAAB



FACTORY PARTS

OVERNIGHT SHIPPING

**20% OFF ALL
 THULE
 ACCESSORIES**



ACCESSORIES

ALL NEW FREE CATALOG

- EXTREME TEES.....15.95
- LEATHER CD TRAVEL CASE.....27.95
- PET WATER AND GEAR BAG.....54.00
- PET TRAVEL BOWL.....17.50
- PET HARNESS (SM, MED, LRG).....19.95

**NEXT DAY or
 SECOND DAY FREIGHT
 AVAILABLE UPON REQUEST**

**LIFETIME WARRANTY
 ON REPLACEMENT MUFFLERS**

MANAGER'S SPECIALS

- 86>93 9000 2.0ltr SERPENTINE BELT.....33.95
- DI IGNITION CASSETTE.....270.00
- >90 9000 5DR HEADLIGHTS.....146.95
- >93 900 FOG LIGHT LENS.....13.00

SAFETY CHECKLIST

- BULBS?
- WIPER BLADES?.....
- HEADLIGHT LENS.....
- TAIL LIGHT LENS.....
- TIRES.....

20% OFF
 Gas Additive
 Washer Solvent
 Pollen Filters
 Wiper Blades



HOURS 8-5 PACIFIC TIME
 MONDAY-FRIDAY

SEE OUR WEB PAGE AT www.cartervwsaab.com

CALL NOW TO ORDER 800-428 8211

If you are not using original SAAB parts,
**YOU MUST BE USING
SCAN-TECH SWEDEN PARTS**



Scan-Tech Sweden is the world's largest
manufacturer and supplier of
SAAB aftermarket parts.

Ask for us by name!



www.ScanTechSweden.com



1 1963 96, 1 case of Amsoil 100:1, add fuel = 2000 miles

I put my old Mercedes out for some restorative work, the '69 96V4 up for sale, and decided to get the '63 96 back into daily-driver mode. It didn't need much, just a voltage regulator, a radiator swap, some reworking of the cooling system, and away we went. My driving patterns are erratic; as a self-employed small business owner, there are days when I don't even go outside. If I do have to go anywhere, I'm far enough out in the boonies that the commute can be at least 50 miles in a day. Add trips to Richmond, and we're talking 100 miles. So the old stroker got her odometer put into over-drive, and 6 1/2 weeks later shows 2000 more miles than when she was last "serviced".

Relying on a 3-cylinder SAAB as you would rely on, say, a 9000 or a more, er, conventional car, requires a little more foresight. Forget to put that carb preheater back on on a cold morning, and you'll get 100 feet down the road in no time flat, but not much further. The old SAABs also had a variety of airflow restrictors to further aid in cold-weather temperature maintenance. As you see in the picture, there are some raised metal plates just forward of the wiper motor (extreme right bottom) and one on the opposite inner fender well. Known to old stroker hacks as "pie plates", these restrictors work in one of two ways; either in the raised position as shown, or in the fully closed position. Spring-loaded metal clips hold them in place. Some of you V4 and longnose 2-stroke owners may notice that you have

the outlines for these on your inner fenders, that's what they are from!

Despite seven moving parts, some other parts like to emulate their brothers and sisters. Take for example one older Solex 40 A1 carburettor, whose body decided to come loose from its throttle plate housing 20 miles from home. The car still made it back to the shop, where a new carb was fitted. With the old mixer 2-strokers, fuel mixture is oil mixture, and the improper amount of oiling per revolution will lead to early

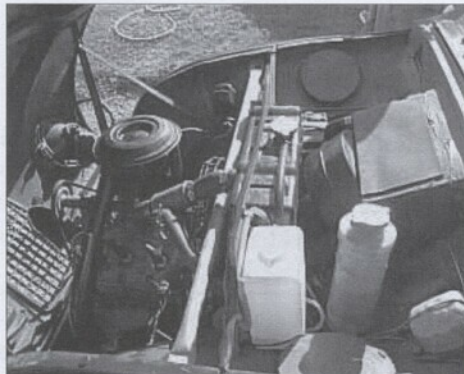

93 engine compartment showing "pie plate" air restrictors.

engine death. The GTs are not exempt here either, despite their independent oiling, their higher compression and increased combustion chamber temperatures will leave you with a holed piston if your mixture is too lean. Once those throttle shafts wear out, air can be sucked in the strictly vacuum carburettor(s) through whatever orifices you provide! Take it from me, two-stroke pistons, cranks and blocks, whether GT or non, in any kind of useable condition are not cheap! So maintain that fuel system, use good oils, and your Mighty Three will likely not leave you stranded late one night in unfamiliar territory.

One last note. Old 2-stroke SAABs have 7" headlamp openings. Have a look at your old car. I bet the sealed beam unit in there isn't even a halogen one. Are you nervous about piloting a Three after dark? Cibie, Hella and a few other manufacturers make excellent flat or convex headlamp conversions which take the H4 bulb as found in modern cars. Here we go again, modernizing the 2-strokers! Talbot, who advertises in this magazine as well as West of Sweden SAAB in Virginia (shameless plug) can provide you with crystal clear lenses and bright halogen bulbs to keep you from introducing your older SAAB to the wildlife, a tree, or that oncoming Grand Excursion Subdivision Explorer, Eddie Bauer Cartier edition with the extra high and extra bright high beams which Soccer Mom forgot to turn off around that last curve. There simply aren't enough older SAABs to sacrifice to such pointless deaths as those, and many among us have had, er, less-than-pleasant experiences with classic cars and insurance companies when it comes to such things.

SOBSTORY NEW/USED/REBUILT SAAB PARTS

DISCOUNT PRICE SPECIALS:

(MUST ASK FOR SALE ITEMS!!!!)

Cool folding Cup Holder	\$25
BOSCH fog lens replacement	\$13
900 cloth dash covers	\$29
89-85-384 99-900 TRW Ball Joint	\$19
Air Mass Meter (006) rebuilt	\$140

Everything Discounted
Visa & MasterCard

800-583-0370

in NJ 90788-7222

SOBSTORY.COM

A Division of:

Moncrief Marketing, Inc.
Flemington, NJ 08822



SPECIALIZING IN PARTS FOR SAAB & VOLVO

OEM, OE & AFTERMARKET PARTS AVAILABLE
PARTS DISCOUNTS UP TO 50% OFF LIST PRICE

CALL FOR MONTHLY SPECIALS

SAAB 1800-32TROLL VOLVO

<http://www.cybertroll.com> 410-682-2827

MOST ORDERS SHIPPED WITHIN 24 HOURS / VISA, MASTERCARD & AMERICAN EXPRESS ACCEPTED

The Jerry Seinfeld Saab Story

I am not only a Subscriber to Nines, but I am also an "active" Turbo! Member (Internet Saab List) as well. When I saw a post that read: "The Jerry Seinfeld Saab is up for auction," I knew that not everything on the Internet was accurate. My good friend had just purchased a genuine Seinfeld Saab, from Patrick Motors of Auburn, Ma., not from an Internet Auction Block.

My friend Frannie Sclar, of Millbury, Mass. just happened upon the car. She was not a Seinfeld Fan wanting a token from the show. She was just a regular Saab owner looking for a new Saab to replace her beloved 88 900 TC. The transmission in her 900 and other various parts were starting to give her trouble, so she decided it was time to go car shopping. The place she chose was her dealership, Patrick Motors of Auburn, Massachusetts, where she has been going for some time. She went to the dealer and talked with the sales people there. When she found out what she could afford, she went looking for her dream car: a Saab convertible. She had a few stipulations: automatic transmission, the color black, and leather interior. One of the salesmen mentioned that they had a couple of the Seinfeld Saabs, and that was it. They went for a test drive and she recalls saying "this is my car!" Having a car that was used for TV and movie's was just "Icing on the cake", a bonus for her.

After I went for a (too short) ride in it, I could see why she loved it at first drive. The car was immaculate! It was hardly ever used and well maintained. The Studio that owned it in Hollywood only put about 6k on it. It was an almost brand new car at a used car price. A Saab is a wonderful car to begin with, but a convertible...is even better! I heard a rumor that the Hollywood executive that was in charge of picking out the cars is also a big Saab fan, and he put some of the miles on this and the other Saabs they have had. I have also had the privilege of driving a dealer car from Patrick Motors while my 9000 was in for service. It too was a convertible. Although it was a newer model (1999 9³), the difference between the "newness" in either car was minimal. Such good care of was her car was taken that the phrase "just like new" actually rings true.

Jerry Seinfeld and friends were not the only famous people to drive in it. There is a whole bunch of Celebrities that have driven this Saab, as shown in the "certificate of authenticity." If you have watched the TV show Dharma and Greg, then you have seen this car. It was, also driven by Dick Vandyke, along with many other famous people. So who's your car's previous owner?

One, day I hope to drive this Seinfeld convertible at length, but right now Frannie is like many other Saab owners: very stingy with the keys. I don't blame her a bit. I am also a Saab owner. (93 9000 CS, 88 900T, and a Sonett on the way!)

While I was researching this car, at Patrick Motors I talked with Mr. Patrick himself. He said they



Frannie Sclar enjoying the "seat of greatness." The 9000 behind is the author's car "Rover".

have another Seinfeld Saab available, as well as the convertible Jack Nicholson, drove in "As Good as it Gets". And Frannie remembers there being another Seinfeld Saab sold about a year ago. So there was not just one, Seinfeld Saab but three. The last

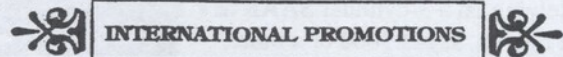

10725 Vanowen Street • North Hollywood, CA 91605
Telephone (818) 755-6333 • Fax (818) 755-6444

July 2, 1999

Mr. James Patrick
Patrick Saab
519 Washington Street
Route 20
Auburn, MA 01501

Re: 1996 Black Saab 900 Convertible
VIN: YS3DF78V5T7010049

Dear Mr. Patrick:

This letter shall confirm that the aforementioned vehicle has appeared in the following Film and Television Programs:

FILM

"Free Enterprise"
"Picking Up The Pieces"
"The Shrink Is In"

PRINCIPAL DRIVER

Mark McCormack
TBD
Courtney Cox

TELEVISION PROGRAM

"Dharma & Greg"
"Diagnosis Murder"
"Seinfeld"
"Soldier of Fortune"
(A.K.A. "S.O.F.")

Jenna Elfman and Thomas Gibson
Dick VanDyke
Jerry Seinfeld, Michael Richards
TBD

Very Best Regards,

Linda M. Swick
Linda M. Swick
President

cc: Lisa Uhl, Saab Cars USA, Inc.

Are You Listening?

At the end of my column in NINES #243, I concluded by asking if you had any evidence of impending failure with your car. Did you give it some thought? How about Page 39 and Norma's interview?

Linda and I were in Dallas, TX in December and had some time so bought a local newspaper. While perusing the sections I happened upon the section called "AUTO WORLD TODAY." On the second page was a feature that grabbed my attention. The name of the feature was, "AAA Offers Tips to Avoid Breakdowns."

Folks that come into our store to buy a used Saab are concerned about the durability of the engine and transmission. I get questions like "How many miles will a Saab REALLY last?" They are REALLY asking if the car will be durable

and dependable (no break-downs and they won't get stranded). These are important questions for people that live in a state that gets down to -30 degrees in the winter. I read the following in SEMA News Magazine, November 1999 issue, about vehicle selection:

"VEHICLE SELECTION FACTORS RATED NUMBER ONE"

FACTOR	PERCENT
Vehicle Durability	59.2%
Vehicle Safety	54.0%
Personal Comfort	48.3%
Vehicle Power	34.0%
Vehicle Practicality	33.1%
Personalized Vehicle Looks	31.6%
Gas Mileage	28.3%
Maintaining Vehicle Value	28.3%
New Gadgets/Technology	11.8%

This survey demonstrates what potential car buyers are looking for. A Saab fits right in, but what makes it durable and dependable? That's right, ultimately it's the maintenance, care and precautions *you* use that will be the determining factor.

This Texas survey I'm using as evidence may be slightly different for different climates in our country, but I'll bet, by not much. The tips in the article were based on roadside assistance data from AAA contracted Tow Truck Operators. The following is the top ten list, not necessarily ranked in order of frequency.:

- 1 Not rotating, aligning or inflating tires.
- 2 Ignoring brake noises or warnings.
- 3 Ignoring fluid leaks.
- 4 Ignoring dashboard warning signs or gauges.
- 5 Defective battery or bad battery connection.
- 6 Worn or cracked belts or hoses/loose hose or belt connection.
- 7 Not checking or changing fluids.
- 8 Worn universal/constant velocity joints on drive shaft.
- 9 Ignoring noise or vibrations from water pump
- 10 Not changing fuel filter.

Fully 75% of all calls to Texas AAA involve towing, battery problems, difficulty starting and flat tires. In a National Study, AAA claimed that 5 million car break-downs per year could be avoided with proper maintenance. The study also showed that many motorists can over-maintain selected items such as changing oil, but just 2% of them believe that belts and hoses are important maintenance items. Does any of this hit home? If you are guilty it's not too late to change before you become one of these statistics. Did you see major engine or transmission failures there? Only through poor maintenance of sub-systems did the cars require the most tows. If you do your own maintenance, be systematic and thorough. If you depend upon a professional, be sure you have proper checkups that include all the common problems (like the recommended Saab major mile service). Ask questions of your professional and be sure he understands your dependence upon him to protect you from all these common maladies.

Saab Celebrity Snoop Continued

time I visited the showroom, they had the last Seinfeld Saab and at least one of the Jack Nicholson Saab's. Someone on Turbo! mentioned that in one of the scenes in that movie, where Helen Hunt drives the car and has a heart to heart with another character, the headrests are different from one scene to another. I am not telling anymore. Go watch the movie yourself and see if you can see it. Maybe there is more than one Jack Nicholson Saab as well?

To get in touch with Patrick Motors and see if they have anymore Celebrity Saabs, try their web site (<http://www.saabdealer.com/patrick2/index.html>) or call them at 508-832-8883.

Added note: If you buy a celebrity Saab, please contact me...I would like a ride and an interview.

Thanks in advance, Heather Henry-O'Connor "NINES Saab Snoop"
Email: aktie9@aol.com

Photograph by the Author. Certificate of use courtesy of Patrick Motors.

GM DRIVERSITE FINDS NEW OWNER

This was the headline in October 18th, 1999 **USED CAR NEWS**. I reported in **NINES #242** that our Daddy was not going to be allowed to market used cars directly to consumers via the internet and thereby excluding its Dealer Network. Peter A. Salinas reported in this article that George DeMontrond II and the automotive group he owns are now licensed to operate this E store (website marketing off-lease or executive cars to the public). While this has happened, in the same issue GM announced that they also want to wholesale cars to its other GM dealers through its driversite. Nationwide, GM expects 450,000 cars off lease in the year 2000. They expect the lease holders or their respective dealers to absorb 250,000 of them, and the rest will be sold at auction or through driversite or some similar action.

Roy Pikus, GM Brand Manager for GM Certified Used Cars, now says that

they had intended to involve local GM dealers from the beginning of the driversite development and given hindsight would have done things differently. Mr. Pikus reported in this article that NADA (National Auto Dealers Association) has been presented with all of GM's plans and Jim Willingham, President of NADA, was comfortable with the situation. Jim Willingham is quoted as saying, "Our job at NADA is to protect the dealer." It seemed like on October 18th that GM was playing ball. Peace and tranquility reigned because GM was living up to its obligation to its dealers. No direct competition!! In the December 1999 issue of Used Car Dealer Magazine, **The Front Line Section** published a unanimously passed resolution by the NADA Board.

In the resolution the board reiterated, "A franchise system of Independent owned and operated dealerships best serves the interests of manufacturers and consumers by ensuring the most competitive and efficient means of distributing and servicing high quality cars and trucks."

NADA will take all appropriate actions, including support for state legislative initiatives, to prevent manufacturers from owning or controlling dealerships other than through bona fide programs such as dealer development and minority dealer development programs.

In the December '99 issue of Trucking Times & Sport Utility News, I came across a small article located in the section entitled **INSIDE THE INDUSTRY "GM Announces Plans to Purchase Dealerships"**. The gist of the article says GM is going to buy 700 dealerships and operate them. The rest of the paragraph is about the outcry from the GM dealers. Why in the world is GM so intent on competing directly with their dealers?

Now that the remainder of Saab has been purchased by GM we must be vocal about what is happening in the auto industry. I believe that the General has been very good for Saab. I think that we can expect great things in future products offered. We may not like the prices if the car manufacturers are to own everything including the dealerships. So you think cars and repair parts are expensive now? Competition is necessary and we need a strong Saab dealership group (dealerships not run by a manufacturer but able to remain independent in ownership).

AutoNation

In early December, AutoNation closed 23 of its used car super stores each having about 1000 used cars and 95-100 employees per location. Car Max (owned by Circuit City) also another used car super store chain is not making a lot of money and may not survive in the long run. Both companies have purchased new car dealerships in addition to the used cars which gives them some help. As the struggle of the gargantuans unfold, I'll try to update you if you don't have the media resources to keep up. The super stores have had an impact on the way used cars are re-marketed over most all of the country. They don't typically have used Saab on their lots but anything can happen!!! Supply and demand of all cars affects the dollar values that ultimately will be paid by you!

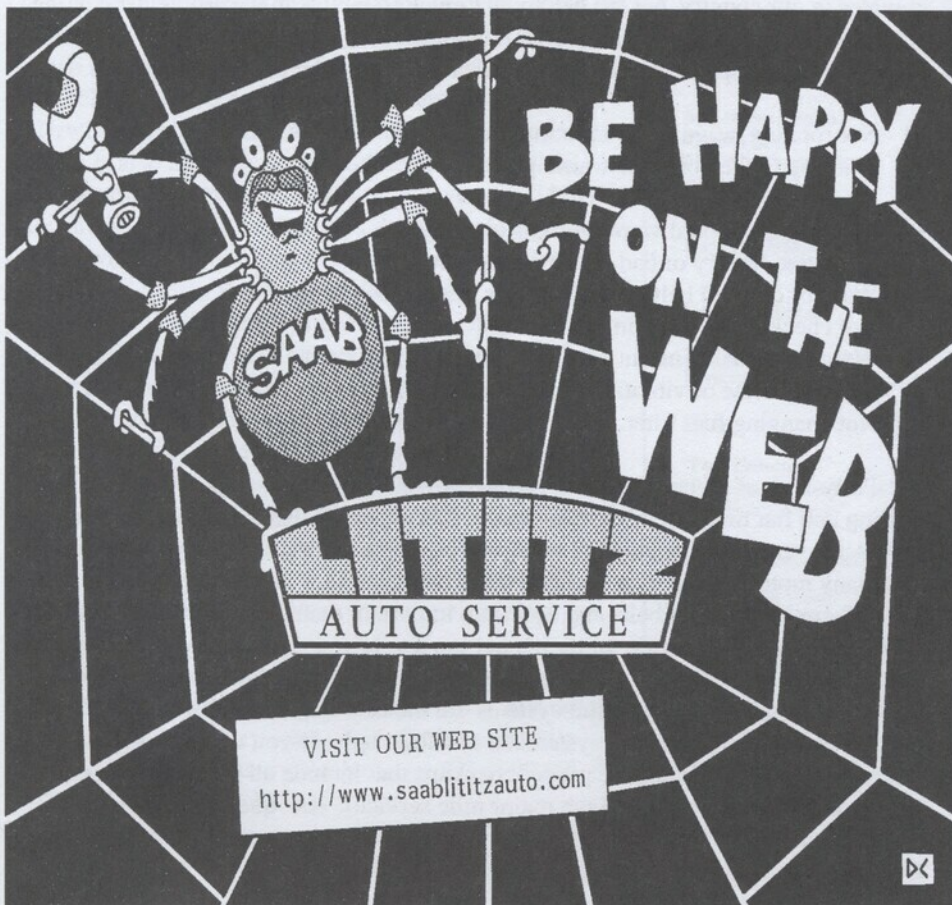

Meyer Garage



On Saturday September 18th, 1999, Marty and Annette Adams, third generation owners of Meyer Garage, McIntire, IA, held an open house to celebrate the 35th year of business as an authorized Saab dealer. Saab USA sent the officials



From left: Lou Manglass, National Parts Marketing Manager; Luke Wisniewski, District Manager; Annette Adams; Ken Grauberger, Regional Parts Manager; Marty Adams; Tracy Garneau, District Parts and Service Manager

pictured, who presented a plaque commemorating the milestone. Meyer is the oldest Saab dealer in Iowa and ranks among the oldest in the country.

Meyer Garage was founded by Marty's grandfather, Edmund, as a farm implement and tractor business selling Minneapolis Moline and Oliver tractors. Marty's father, Jerry, was working for O.E. Borton, a Saab dealer in Minneapolis, as a mechanic during the day and a sales person in the evenings. Impressed by the quality of the 93, 95, and 96, he persuaded Edmund to become a franchised Saab dealer. Meyer Garage began selling Saabs in 1964. In 1977 Jerry purchased the business from his father, and in 1997 Marty purchased the business from him.

How does a dealer, seemingly located in the middle of nowhere, continue as an

exclusively Saab dealer for 35 years? "Excellent service," answered Marty. They provide continuity of service from technicians who have been employed for over 20 years. Their lean staff of 3 technicians, a receptionist, and Marty and Annette keeps overhead low, and their "family oriented" facility makes the population which they serve

comfortable when shopping Saabs. The owners they serve may not be typical of Saab owners in the major metropolitan areas. For example, about 70% of new Saabs in the USA are leased. At the Meyer Garage, the number is around 25%, and even that is partly a result of lease incentives which translate into a substantial discount for "leasing and then purchasing" versus an outright purchase. "I don't rent my house, I don't rent my clothes, why should I rent my car?" Marty said of his customers' attitude toward leasing. As for location, McIntire, IA is within an hour or so drive from medium sized cities including Rochester, MN, Mason City, IA, and Waterloo, IA.

Also on display for the 35th anniversary was the newly remodeled (to the new Saab specs.) showroom. The showroom is decorated in blue, beige floor, off white walls with generous use of naturally finished wood, making for a very attrac-



Members of the Minnesota, Iowa, Great Lakes, and Milwaukee Saab Clubs joining in the celebration.

tive facility. The Minnesota, Iowa, Michigan, and Milwaukee Saab clubs were represented at the event. Members arrived in a variety of modern to great vintage Saabs. It was a great day topped off by a steak dinner provided by the hosts. Congratulations to Marty and Annette on a fine event and thanks for supporting the local Saab clubs and Independent Saab shops.

Photographs by the author.

For the Friendly, Helpful Service and Genuine Saab Parts you've come to expect, call:

1-800-705-SAAB
or
1-609-924-5101

SPORTS AND SPECIALIST CARS

1023 STATE ROAD
PRINCETON, NJ 08540

Authorized **SAAB** Dealer

fax: 609-924-8461
E-Mail: sns cars@aol.com

NOKIAN TIRES

www.snowtyres.com

185/65-15T NRT 2 all season	\$57
195/65-15T NRT 2 " "	\$59
185/65-15H NRH summer	\$55
195/65-15H NRH " "	\$59
195/60-15H NRH " "	\$59
195/65-15H NRW H (set of 4)	\$285
195/60-15H NRW H " "	\$290
205/55-15V NRV summer	\$97
195/60-15V NRV " "	\$75

GISLAVED SPEED 506

195/65-15H set of 4	\$239
---------------------	-------

WHILE SUPPLIES LAST

Bentley Manual 900 8 valve	\$27
Mann oil filters (black) (10)	\$37

with purchase of 4 tires, limited

G & G SERVICE
4073 HUBERTUS RD
HUBERTUS, WI 53033
414-628-1716
DISC, VISA, MC & AMEX

The week of January 9th was the "Media Preview Week" at the North American International Auto Show. Unlike the days when the show is open to the public, the crowds are sparse and mostly gathered at the press conferences which follow one another throughout the week. This allows for ample opportunity to photograph the exhibits and speak with the company representatives: representatives like Dan Chasins, President of Saab Cars USA, Inc., and his counterpart (some might say "boss") at General Motors, G. Richard Wagoner. With one day to spend at the NAIAS, we naturally chose "Saab Day."

We spent the most time in the vicinity of the General Motors Pavilion. The Press Conference introducing the Pontiac Aztek and a truck was just before noon. Saab's Press Conference, introducing the Aero Wagon and discussing General Motors' decision to exercise its option to assume 100% ownership of Saab, was the last media event of the day. We saw some vague familiarity in the hatchback shape of the Aztek, although the styling is anything but Scandinavian. The versatility and packaging are intriguing. The vehicle will be built in both FWD and AWD versions, indicating that GM has developed an AWD system which is compatible with a transverse-front-engine automobile (not truck based) chassis. In NINES #242 we reported in our interview with Dan Chasins, President of Saab Cars USA, Inc., that an AWD Saab is a near certainty, and perhaps the Aztek chassis shows a hint of what is coming. The styling certainly does not.

The Saab press conference itself was a little unusual in that there were two major but unrelated issues to discuss: the assumption of full ownership of Saab Cars

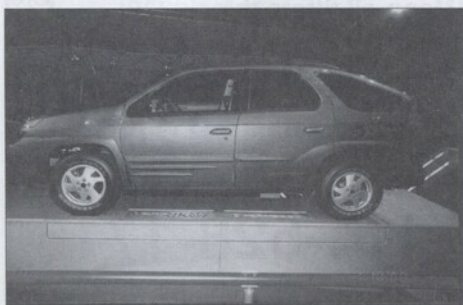

Pontiac Aztek, GM's first "cross-over" AWD offering.

by GM and the introduction of the Aero Wagon. The press conference started off with an updated version of the Saab multimedia video seen by many subscribers at the 1997 Waterville Valley Owners' Convention which left its usual impression on the audience. Peter Augustsson, Chief Executive Officer of Saab Automobile AB, spoke first, followed by Richard Wagoner.

Saab was eager to point out their 29% sales gain for 1999 over 1998, but the

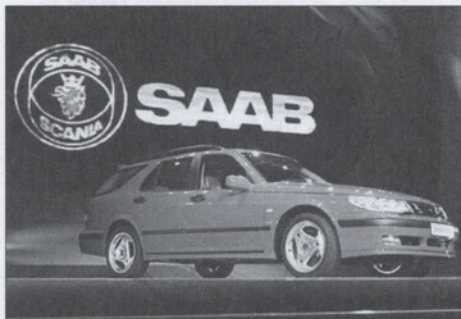

9⁵ Aero Wagon on display at Saab's Press Conference

companies which Saab considers as their competition also had a strong sales year. We attended product introduction press conferences by Volvo and BMW, with both companies reporting both healthy sales increases and record sales. Saab's percentage increase was greater, leading to a greater market share in their "near luxury" market, but the results were less than the record year of 1987. Truthfully, we found all the talks about 1999's sales could have been written by the same author, each company touting its marvelous products, hard working dealers and employees, and heritage and continuity. Most telling for Saab was a slide comparing the 1999 sales of the 9-5 with the best year ever of the 9000: 1988. Despite having the wagon on sale for only half the year in the US, and lacking a high performance model for all but the last few months of the year, the 9⁵ in 1999 handily beat the 9000's 1988 performance. In the United States, the 9⁵'s 1999 sales exceeded the 9000's 1988 sales by 41.5%.

Augustsson went on to predict continued strength in Saab's current models and a further broadening of Saab's product line. Having offered that new design 9³ was in progress, we asked during the Q&A whether the hatchback

concept would be continued, or if a more common sedan and station wagon combination would be offered. The reply was that Saab would continue to offer products that would fill the needs of their current customers while attracting new customers. Based on the wide array of attractive small wagons on the show floor, and based on the 9⁵'s results, we predict "sedan and wagon," with a convertible model, and perhaps a coupe, produced on a separate production line.

The Volvo press conference featured the introduction of a new "V70" mid-sized

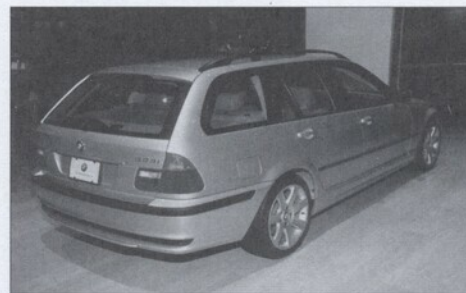

BMW 323i Station Wagon competes with the 9³



VW's Passat Station Wagon and the similar Audi A4 compete with the 9³



Volvo V40 compact Station Wagon competes with the 9³

wagon. Using the platform of the S-80 sedan, the wagon version is slightly shorter than the S80. It uses the 5 cylinder engine line from the current V70, and is every bit as boxy as current wagon. It shows some interesting details. A coat hook on the side of the passenger's seat

was said to provide "easy access to a cell phone". We'd prefer that the cell phones be left in a locked luggage compartment, but we see the benefit of the hook for tolls and even umbrellas. A "hard point" on the passenger's side of the center console allows for the attachment of a variety of accessories, including a purse holder and a holster for that cell phone. In the back, Volvo answers Saab's "Cargo Track" and net combination with a fold-up grocery bag rack. There was no roll-out load floor, no refrigerated glove compartment, and no hatch-mounted spotlights. There is an AWD version, complete with increased ground clearance, larger tires, and some vaguely truckish styling cues.

BMW introduced a less expensive version of their "X5" AWD. With a 3.0 L in line six cylinder engine, its price of under \$40,000 makes it a strong price competitor to the 9⁵ Wagon, and undercuts BMW's own 528 Wagon. The 323 wagon was on display, with the kind of multi-adjustable sport seats that readers have encouraged Saab to put into the 9⁵ Aero. The small BMW wagon had one spotlight in it's hatch.

BMW also announced the intention of importing the next generation "Mini" to the United States, no doubt encouraged by the strong sales of VW's "New Beetle." We question whether the Mini can generate anywhere near the "nostalgia" quotient that VW captured. We don't recall seeing that many of them around, even in New England where we lived when the Mini was sold in the US. We also think that the average Mini test drive will last only until the driver looks up to the belly pan of a Ford Excursion.

VW/Audi proudly displayed cut-away engines and drive trains to highlight their Quattro and Twin Turbo V-6. The complexity in the engine and drive train is the antithesis of Saab's product philosophy. The Twin Turbo V-6 sports four catalytic converters, two of which are integral with the exhaust head pipe, two cam timing chains and one cam timing belt, and of course the twin turbos. The transfer case uses a mechanically complex "Torsen" differential, and the rear drive portion sports seven universal joints to go with the four for the front-drive wheels. I've learned from both my engineering career and my years of automobile

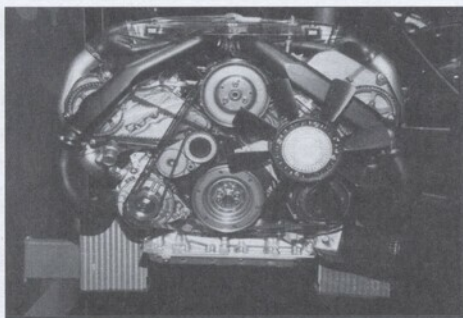

Audi's 2.7 liter twin turbo V6 engine shows its width and complexity

ownership that components eventually wear and fail, and complicated components tend to wear more rapidly and fail more frequently and more expensively than simple, robust designs. In this era of lease-for-three-years-then-out, it's the second and third owners who bear the risk of such designs. I believe that long term buyers and used car buyers will have better luck with Saabs.

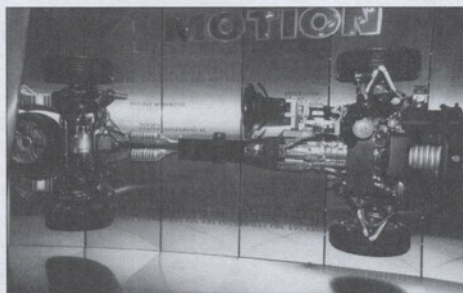

VW Audi AWD design shows its complexity and weight .

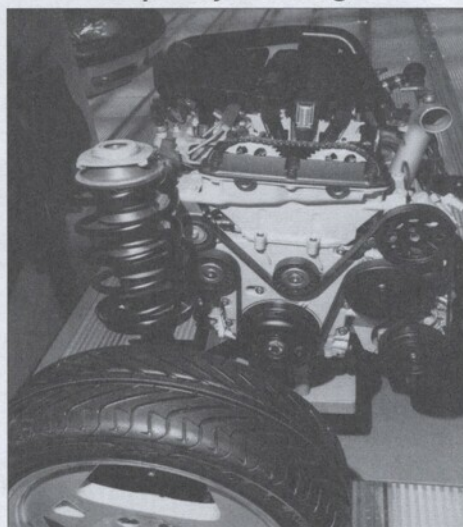

The Saab 9⁵ Aero drive train is compact and elegant.

We enquired at the Michelin booth about the progress of their Pax System tire design. As shown in NINES #239, Pax promises better handling, improved

vehicle packaging, and economical extended mobility (run-flat) capability without the ride and handling penalties of self-supporting sidewalls. We were told that development work is progressing on schedule and that prototypes are delivering the claimed benefits.

GM had a display of its in-line 4 cylinder "Global Engine" teamed with a CVT transmission. They also showed a prototype self-shifting, self-clutching standard transmission, together showing that GM's Powertrain Division is serious about developments which improve fuel economy over today's automatic transmission. Noteworthy features in the Global Engine include chain driven dual overhead cams and counter rotating balance shafts integral with the block housing. GM's web site shows that a turbocharging option is included in the engine's design. A variable valve timing mechanism has also been designed for this engine. At this time the Global Engine is used in the Saturn LS as its base engine.

The Global Engine uses a cast aluminum block with iron cylinder liners.

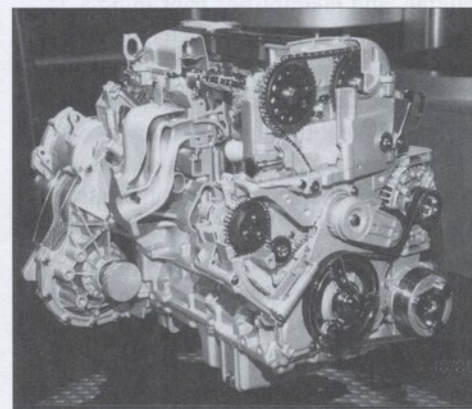

The GM "Global 4" engine showing balance shafts and chain driven overhead cams.

Exploiting the "lost foam" casting technique, which GM pioneered, the engine includes such intricacies as a cast-in oil filter housing. For oil filter changes, a cover is removed and only the filter cartridge is replaced. Such filters were common in the past, but the filter housing was stamped sheet metal and bolted onto the engine, not part of the block casting. If nothing else, filter makers will have a difficult time hiding shabby filter media. In another bit of integration, the water pump is driven by the balance shaft idler

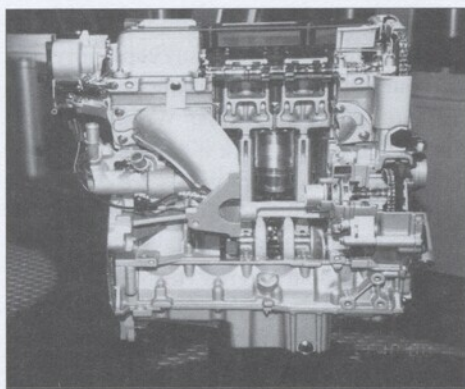

Another view of the GM Global 4

sprocket. The pump itself looked like an excellent design, but since a seized pump means a broken drive chain, we'd recommend that owners of this engine pay attention if they find coolant drips on the garage floor. It appeared to us that the water pump is easily changed from the rear.

One curious design feature is the intake manifold being located on the side facing the front of the car. This arrangement gives better access to the more frequently serviced intake side of the engine, and it simplifies packaging a catalytic converter close to the exhaust manifold. With the proliferation of V-6 transverse designs, the issue of engine noise and heat through the firewall can be resolved with existing designs. It is Saab's trademark turbocharging that becomes more difficult, with long ducts leading from the rearward mounted exhaust to the front-mounted intercooler. At least the intercooler outlet is close to the engine inlet.

Accountants in the readership will no doubt discover from the photograph that the accessory belt is driving one-too-few accessories: there was no power steering pump in place. In a future issue we will deal with "Electric Assist Steering", and why owners and car companies, and environmentalists will like it.

Will this engine ultimately replace the venerable Saab in-line 4, and would that be a "bad thing"? We think that any such action would be several years away, because so many of GM's 4 cylinder engines are either antiquated or lack the refinement which today's buyers demand. The Saab engine, by comparison, is one of the best of its kind. Note that many design

details in the Global Engine show the influence of Saab's engineering, so the Global Engine isn't exactly foreign to Saab. To us, this engine looks more like a Saab engine than any of the dozen GM engines which it will be replacing. We have previously observed that the 2.0 Saab engine suffers in low-rpm off-boost performance because of its large bore and short stroke, a condition not present in the Global Engine. The engine factory in Södertälje is a leased building located

within the Scania Truck complex. Scania is finalizing their merger with Volvo AB (that's "Truck" Volvo, not to be confused with Volvo Cars, which is part of the Ford Motor Company), and Saab is now wholly owned by General Motors. At some point we think GM will want to consolidate engine production. With the V6 engine in the 9⁵, Saab and GM have shown the capability and willingness to significantly modify a broadly used engine to meet Saab's unique needs. I'm not worried.

ROBERTI

M O T O R C A R S

Specializing in
previously owned **SAABs**

UNITED STATES' LARGEST DEALER IN USED SAABS

Always 70-100 pre-owned Saabs

from \$3,500 to \$25,000

Home of the 100% Warranty



SAAB Authorized
Warranty Center

EXPERT **SAAB** SERVICE

SAAB PARTS (NEW & USED)

914-339-SAAB

www.roberti.com

385 Foxhall Avenue,
Kingston, NY 12401

GM Acquires Full Ownership of Saab

On January 10, 2000, GM made it "official" and announced that it intends to exercise the option to buy the remaining 50 percent of Saab Automobile AB from Investor AB, the Swedish industrial holding company, with which the GM group has shared ownership for the last decade. The GM group expects to have taken full ownership of Saab by the end of January. The terms of the exchange were not announced at the request of Investor AB, but one suspects that a careful reading of GM's 2001 annual report would reveal the price.

"Over our 10 years with Saab we've seen increasing market success and expansion of the Saab brand internationally," said GM President and Chief Operating Officer G. Richard Wagoner, Jr. "We've had a great relationship with Saab and appreciate our association with Investor, our joint-venture partner. During this time, the Saab brand has maintained its unique identity while we've been able to capitalize on marketing, purchasing and product-development synergies.

"This logical next step of exercising our option to take full ownership will be to move ahead even faster in developing new innovative Saab products, contributing even more to a globally diverse portfolio of resources, expertise and products."

Saab Introduces Aero Wagon

Saab's newest offering in the United States is the Aero Wagon. Its introduction to the United States is being speeded up from its originally scheduled September 1, 2000 introduction in the US as a 2001 model.

There will be approximately 325 MY2000 Aero Wagons. All will have BBS 2pc. Alloy wheels installed at the port, and all will have heated seats. Colors will be limited to white, black, and "Imola (arrest me) Red." A substantial percentage will be equipped with Saab's exclusive ventilated seats. A Saab spokesperson said "With the car being available in Europe, both customers and journalists were asking why the car wasn't available here. When the factory told us that some could be made available early, we quickly accepted."

December and January Sales Data

Saab sales continued to struggle over the two month period, recovering somewhat in December as the 9⁵ sales nearly matched those of the less expensive 9³, then faltering in January. Commenting on January sales, a Saab spokesperson stated that January, 1999 sales were boosted by substantial fleet sales (Budget Car Rentals being the largest fleet customer), while in January 2000, there were none. Excluding fleet sales, the decrease was some 8%, and very near Saab's target of 2000 "retail"

sales in January despite the extreme weather that hampered sales in the Southeast Atlantic Seaboard. Fleet sales can vary significantly from month to month, especially for a small volume producer like Saab, and January's shortfall will be seen in future months. Saab's spokesperson mentioned that fleet sales are counted in the total because they do represent "cars on the road", and that at the end of their rental period these cars are quickly absorbed in the used car market. By contrast, cars used by Saab in their own fleet are not counted as new car sales when they enter service with Saab (they weren't sold), and are also not counted when they are subsequently disposed of (they aren't new).

	Dec	Jan	Period
model 900	7	5	12
coupe 9 ³	118	36	154
viggen coupe	54	35	89
sedan 9 ³	507	291	798
sedan 9 ³ se	330	259	589
viggen sedan	10	14	24
convertible 9 ³	266	312	578
convertible 9 ³ se	174	211	385
viggen convertible	12	6	18
total 9 ³	1471	1164	2635
model 9000	3	8	11
sedan 9 ⁵	372	140	512
sedan 9 ⁵ se	213	34	247
sedan 9 ⁵ V6 (se)	332	269	601
Aero 9 ⁵	135	118	253
wagon 9 ⁵	250	97	945
wagon 9 ⁵ V6	91	2	93
wagon 9 ⁵ se	41	140	181
total 9 ⁵	1434	800	2234
IDS	5	2	7
total 1999/2000	2920	1979	4899
previous year	3542	2774	6316
percent increase	-17.56	-28.66	-22.44
1999 year total	39541		
1998 year total	30757		

WE STRAIGHTEN DENTED ALLOY RIMS!



We turn your dented rim into a straightened rim at mfg. specification with our patented machine!
\$99.99 Per Rim (Incl. shipping back to you)

Service Above & Beyond
 9 Summer Street, Ashland, MA 01721
Call 1-508-881-1999

Spring Romp 2000

Do you want to see a scene like the one shown in *your* rear view mirror? Deb and Dean Lusby are organizing Spring Romp 2000, their early-in-the-year version of "SaabToberfest".



They have scheduled the year 2000 Spring Romp for April 1.

For more information contact Deb at her email address: blaithin@ptd.net, or contact either the Central Penn SAAB Club or the SAAB Club of NE Pennsylvania. *Photograph by Alan Snelson*

Shortly before the 1999 Saab Owners' Convention in Keystone my wife asked me about the itinerary. I gave her a copy of the program and she went to the library and got a video and book by Baxter Black. I listened to the video that night. On Wednesday, while I was packing up my 2,000 lbs worth of parts (filling a trailer and the back of 2 classic 900 Turbo's), I was trying to think of a way to tell people that I really wanted to get rid of this stuff, not make a killing, and that whatever was left near the end would be free. The first verse of this poem popped into my head and I worked on writing the rest of it while I was packing the stuff.

SAAB V4 Parts for Sale
A "Cowboy" Poem by
Charles H. Stoyer

Thirty years of collecting V4's
Has left me with quite a large store
Of SAAB V4 parts
That were dear to my heart
But now I don't need them no more.

Now some of this stuff is just junk.
Hell, the seats are missing a chunk.
The front axle's busted
The fenders are rusted
And the steering rack's all full of gunk.

But this once was a treasure to me
And that's why I came here to see
If you "Birds of a Feather"
Could just tell me whether
This just should be buried at sea.

I have tried to price them to sell,
But if it's too much, what the hell,
Just make me an offer
To add to my coffer
So I can just bid it farewell.

The prices go down every day
As I near the end of my stay
The last hour of this spree
Most stuff will be free
Else it's off to the dump anyway.

The Dump would be easier, I say,
Or pay someone to haul it away.
But there might be a part
That is dear to your heart
And I'll give you a smile today.

And then my conscience is clear.
All the stuff that once was so dear,
I guess it's all bunk
What's left is just junk,
And off towards the dump I will steer.

Copyright © 1999 Charles H. Stoyer
All rights reserved
Charles Stoyer, Golden CO USA

*We hope that this poem encourages
Convention Attendees to start cleaning
attics, basements, and garages for the
Convention Swap Market. - Ed.*



The Minnesota Saab Club, Andrews of Princeton, Inc., and Meyer Garage, Inc., are hosting BLÅ RØK- VINTAGE SAAB 2000. The event will be held on the grounds of Andrews of Princeton - in Princeton, MN from June 9th through June 10th.

The event will celebrate the sights, sounds, smells and BLÅ RØK of two-strokes, V-4's and the model 99. Of course all vintage cars and their owners and any interested bystanders are encouraged to participate.

Princeton is just a short drive north of Minneapolis/St. Paul.
Close to shopping and recreation for all to enjoy.

Event highlights:

- Celebrity Saab guests -
- Saab night at Princeton Speedway -
- Restoration tech sessions -
- Parts swap -
- Vintage car tour -
- Rum River Festival and Saab car parade -
- Swedish heritage, entertainment and food -
- Vintage parts auction -
- Car concours and judging -
- Games and activities for young and old -
- Banquet and awards ceremony -

Fees:

Pre-registration fees are due by May 1, 2000

- \$50 per registrant - includes commemorative T-shirt (pre-registers only), window decal, on-site amenities and meals.
- \$75 for family - includes one registrant plus up to three family members for on-site amenities and meals.

Accommodations:

Many area hotels are available. A list will be mailed along with the registration materials.
REMEMBER! Hotel room is your responsibility! Inquire and book early.

Registration:

Registration is available three ways: by US mail, by e-mail, or on the website (listed below).
All methods will receive registration materials by mail.

contact: Minnesota Saab Club 200 East 66th Street Richfield, MN 55423
e-mail to pgp17@juno.com

Check the website regularly for updates and added attractions.
<http://sites.netscape.net/paulpoore/vintage>

2000 Saab Owners' Convention at Hudson Valley Resort

Saab Cars USA, the New England Sonett Club, and the New Jersey Saab Owner's Club have chosen the Hudson Valley Resort, in the foothills of the Catskills of New York as the headquarters for the 2000 Saab National Owners Convention. The resort is located less than 100 miles from The Big Apple – New York City, and a short drive from Interstate 87. Here are some of the highlights that participants can look forward to:

SAAB HIGH PERFORMANCE DRIVING SCHOOL

On Wednesday, July 5, at historic Lime Rock Park in northwestern Connecticut, Saab owners will have the opportunity for professional instruction by a team of experts from the Skip Barber Driving School. For the first time, there will be an advanced class designed for drivers who have either participated in a prior Saab High Performance Driving School (1997 or 1998), or have other relevant

racing, pro rally, or autocross experience. The driving school is available only for registered convention attendees, and will entail an additional fee. Space is limited.

complement of track activities for every participant. Participants may opt to tour the track in their own vehicles at a leisurely pace during the "track tour", or at speed with an instructor giving basic guidance during the high speed "lapping sessions." A timed Autocross Competition will allow owners to test their driving skills and their car's performance capabilities against owners of similar Saab models. Novice as well as experienced drivers are invited to race around the cones in search of valuable bragging rights. A nominal fee applies.



CONVENTION ACTIVITIES - JULY 7-9

A welcome reception will be hosted by Saab Cars USA staff, the convention organizing committee, rally Legend Erik Carlsson and other special guests. At Saab Seminars, learn more about your Saab's mechanical systems as well as its heritage. Join experts from around the world as they

TRACK DAY AT LIME ROCK PARK
Thursday, July 6 features a full

SPRING IS AROUND THE CORNER! IT'S TIME FOR OUR ANNUAL SPRING SALE

Abbott Racing Springs

Classic 900 - Reg. \$500.00 - *Special \$400.00*
New Gen. 900 - Reg. \$550.00 - *Special \$440.00*
9000 - Reg. \$550.00 - *Special \$440.00*
9-3 - Reg. \$550.00 - *Special \$440.00*

B&G-Suspension Springs

Classic 900 - Reg. \$370.00 - *Special \$280.00*
New Gen. 900 - Reg. \$350.00 - *Special \$265.00*
9000 - Reg. \$370.00 - *Special \$280.00*
9-3 - Reg. \$299.00 - *Special \$225.00*

Special order from the manufacturers - Orders must be placed by April 15, 2000.

Performance for your:

900 9000 9-3 9-5

We are proud importers of *Abbott Racing Motorsport Products*

Accelerated Response Motoring

1940 Ellesmere Road, Unit 19, Toronto, Ontario, Canada M1V 2H7

Tel: (416) 636-8797 or Toll Free: 1-888-767-7333

Fax: (416) 438-7003

Email: info@acceleratedresponse.com, Internet: www.acceleratedresponse.com

discuss topics ranging from Saab aircraft history to two stroke restoration. Learn how to squeeze more performance from your turbocharged Saab, or how to bring out the beauty in your Sonett's paintwork. Saab factory representatives, Saab Club members, and others faithful to the marque will be on hand to answer your questions and give advice on how to make your Saab perform and look its best. The traditional Concours de Saab will determine the most original and beautiful cars at this year's event. Owners will compete for top three honors in each model class, as well as for special and modified cars.

No racing or rallying experience is necessary to compete in the Saab fun rally; just bring a sense of adventure and a keen eye for details. Travel around the twisty back roads of the Catskill Mountains, and keep an eye out for the area's abundant wildlife. Keep your eyes open, answer questions about the things you pass, and you'll be among the top finishers eligible for fun prizes.

From a hubcap for a 1958 Saab 93, to a model of your new Saab 95, you are sure to find what you're looking for as

vendors from around the country sell items from their collections of useful and hard to find parts. Saab will also be on hand with a full selection of parts and goodies to bring excitement to your Saab, bookshelf, or wardrobe. Photographers will showcase their cars and their talents in the 3rd annual Saab Photo Contest. Entries will be in three categories: Saabs in Competition, Car Portraits, and Kids and Saabs. 1st, 2nd and 3rd place winners in each category will receive prizes. Photos will be displayed throughout the convention for inspection by convention attendees and voting for the "Peoples Choice":

For the younger Saab enthusiasts, on Saturday Camp Saab provides a full day camp with lunch and an evening pizza party. Babysitting and a Friday camp are also available through Hudson Valley.

Saab special guests, Convention staff and your fellow Saab enthusiasts will join for the traditional Saturday night Banquet and Awards Contest, including a drawing for terrific door prizes from our sponsors.

REGISTRATION INFORMATION

Walk up registration will not be

offered during the 2000 Convention. You must pre register, and you are responsible for your lodging arrangements.

Convention planners have negotiated in season rates with the Hudson Valley Resort in Kerhonkson, NY. As the headquarters for the 2000 Convention, Hudson Valley offers warm Catskills summer hospitality, a health Spa and full amenities. You can reserve your room by phone at 1-888-948-3766 toll free. Remember to ask for group number Plan Reserve your room early as space is limited at this highly desirable summer vacation spot.

Registration flyers will be mailed out to all NINES subscribers, previous convention registrants, and many others. If you have received Convention Registration Flyers in past years, you should receive one this year too. For more information or to request a flyer, simply call 1 800 438 7222, option 6. The Convention's website at www.saabconvention.org and NINES website at www.saabclub.com will have "PDF" files of the registration forms which you can download and print.

International SAAB Club Meeting 2000

9 - 12 June 2000 (Whitsun)

Luzern, Switzerland (CH)



General:

The Saab-Club Schweiz will celebrate its 15th anniversary in the year 2000, which is one of the reasons why it will be organising the International Saab-Club Meeting 2000. The meeting will take place in Luzern in the heart of Switzerland.

Registration:

In writing, by way of the registration form which should be sent to:
Saab-Club Schweiz, Fridolin Spälti, Reidholzstrasse 9 B, CH-8805
Richterswil/Switzerland
or via Internet: www.saabclub.ch.

Registration deadline: 10 March 2000

Fees:

The registration fee should be transferred, by 10 March 2000 at the latest, to the following bank account:

UBS Hochdorf 288-420264.40D, PC 30-35-9, Swift-No.
UBSWCHZH60A

Adults CHF 150.- / children 6-14 years old CHF 80.- / children under 6 free.

Contact:

Saab Club Schweiz
Fridolin Spälti
Reidholzstrasse 9B
CH-8805 Richterswil/SWITZERLAND

E-Mail: spaelti@dplanet.ch

Tel: ++41 1 784 63 47

Internet: www.saabclub.ch

For complete information, including a copy of the registration form in printable "PDF" format visit our web site at
<http://www.saabclub.com>

North American Saab Club Contacts

Appalachian SAAB Club

Ken Edwards
296 Brethren Church Rd.
Jonesboro TN 37659-
423-753-3153

Bay Area SAAB Club (Northern California)

Douglas Morse
25291 Morse Ct.
Hayward CA 94542-
510-582-1858
Email:saab_club@prodigy.com

Carolinas Saab Register

Jason Henske
2830 16th St. NE Apt. #99
Hickory NC 28601-
704-256-9211
Email:NCSaabreg@AOL.com

Central Penn SAAB Club

George Basehore
477 E. Main St.
Middletown PA 17057-
717-944-2915

Central States SAAB Club

c/o Kyle J. Poppert
4015 N Street
Lincoln, NE 68510
402-488-5730
saabarts@aol.com

Delaware Valley SAAB Club

Pat Bolmeyer
1311 Clifford Rd., Oak Hill
Wilmington DE 19805-
302-994-2173

Gateway City Saab Club

Greg Cassidy
3256 Bainburry Ct
St. Louis, MO 63129
314-318-8508

Great Lakes SAAB Club

Jim Laman
617 Beechwood
Holland MI 49423-
616-335-5215
Email:lamanjim@juno.com

Green Mountain SAAB Club (Vermont)

Cathleen Pembroke
RFD #5, Box 2758
Montpelier VT 05602-8812
802-476-7994
Email:sbprods@earthlink.net

Gulf Coast SAAB Club

Ron Hernandez
2422 Killdeer St.
New Orleans LA 70122-4316
504-283-0822
Email:rthrnandz@AOL.com

Milwaukee SAAB Club

Andy Saksa
2480 Eastwood Ln.
Brookfield WI 53005-
414-785-1550

Minnesota SAAB Club

Dean Nelson
1420 15 Terrace NW
New Brighton MN 55112-
612-636-3771

New England Sonett Club

P.O. Box 4362
Manchester NH 03108-
Email:sbprods@earthlink.com

New Jersey Saab Owners' Club

Larry West, Chairman
465 Tappan Avenue
North Plainfield, NJ 07063-1823
908-507-6691
njsoc@pobox.com

Northwest SAAB Owners (Washington, Oregon, British Columbia)

Skip Schott
20220 80th Ave. SE
Snohomish WA 98290-
425-486-1351

Rocky Mountain SAAB Club

Jerry Danner
519 Lipan St.
Denver CO 80204-
303-595-4646

SAAB Club National Capital Area

Alan Crosby
11886 Purcell Road
Lovettsville, Va 20180
540-882-4008
alancrosby@aol.com

SAAB Club of Central Ohio

Dan Orzano
2434 Dover Rd.
Columbus OH 43209-
614-231-3892
Email:dorzano@compuserve.com

SAAB Club of Georgia

Chris McPherson
915 Franklin Goldmine Rd.
Cumming GA30040-
770-844-5961

SAAB Club of Iowa

Marty Adams, President
PO Box 99
Stacyville, IA 50476
515-737-2239
email: info@myersaab.com

Saab Club of New York

Laura Delehanty
385 Foxhall Avenue
Kingston, NY 12401
914-339-7222

SAAB Club of NE Pennsylvania

Ron Augelli
1723 Clearview St.
Scranton PA 18508-
717-969-9863

SAAB Club of Texas

Craig Bobchin is no longer a resident of Texas, and we have not received information of a replacement. Please contact NINES if you know!

Saab Owners of Canada, Inc.

John Casey, Pres.
4214 Dundas St. West Suite 106
Toronto, Ontario
Canada
M8X 1Y6
Bus. 416-239-2193
fax. 416-239-6228
email: ruefulsaab@hotmail.com

San Diego SAAB Owners' Group

Chris Rogers
10559 Lansford Lane
San Diego CA 92126-
619-530-0019
Fax: 619-530-0096
Email:annexus@abac.com

Southern California SAAB Club

Paul Florance
126 1/2 Main St.
Seal Beach CA 90740-
562-493-6707

Tristate SAAB Club (OH, KY, IN)

Phil Lacefield Jr.
235 Bellaire Ave.
Dayton, OH 45420
(937) 254-6975
phil@lacefield.com

Utah SAAB Club

Chris Cox
P.O. Box 526105
Salt Lake City UT 84152-6105

Western Pennsylvania Saab Club

Andy Bittenbinder
9433 Katherine Drive
Allison Park PA 15101-
412-366-6165

Little Swede Coupe*

**with apologies to the Beach Boys - ed*

Dan drives a Sonett with a difference, and what a difference! One look is all it takes to know that this is not your ordinary Sonett. The huge rear tires are the first giveaway, then there's the wheelie bars hanging off the back. Yep, it's a drag racer, rear-wheel driven, and capable of quarter-mile speeds up to 116 mph in just 12 seconds.



Wheelie bars and massive rear slicks show that this is no ordinary Sonett.

The car was built by Dan Bollschweiler, a Saab Master Technician at Mike Shaw Saab in Denver. Working at a Saab dealership has given Dan the background and knowledge to create his Franken-Sonett, which he has named "Just 4". The name indicates that there are just four cylinders to the engine, but also is vague enough to get spectators to ask about it, and to inquire more about the Sonett itself.

The car began as a 1972 Sonett III. Much of the original chassis has been converted to tube frame to accommodate the added horsepower and other refinements required for point-and-shoot driving. The main part of the frame is 2" by 4" rectangular tubing, with 1-5/8" round tube for the roll cage. The stock front Sonett spring towers have been grafted onto the new frame.

If the body looks a little longer than most Sonetts, that's because it is. Three inches were added to the gap between the hood and the doors. This was done to meet National Hot Rod Association rules regarding minimum wheelbase. In addition, the rear axle is moved back several inches. Since the car is rear-wheel driven, it features a solid, Ford 9-inch differential/axle unit, a popular choice amongst racers for ease of changing the ring and pinion. The rear tires are 12-inches wide across the tread, but there is

room to go to 14-inch tires. The body has been widened a couple of inches at the rear to accommodate the wider tires.

The power comes from a fairly stock 2.0-liter Saab turbocharged four-cylinder salvaged from a 1990 9000 Turbo. It retains the stock fuel injection system and the Saab Direct Ignition, and the turbo is a standard Garrett unit from a '96 9000. Dan runs the turbo pressure up to 45 psi with no wastegate, and has had few engine problems. The intercooler and radiator also came from 9000s. Since the engine is mounted with the flywheel to the rear instead of transverse like in the 9000, new intake and exhaust manifolds had to be fabricated.

Power is transferred through a General Motors Turbo 350 automatic transmission with a custom built flex plate. Originally, Dan had used the stock Saab flex plate, but it tore up the pump for the transmission.

What does it take to slow down a Sonett dragster? The stock Sonett disk brakes are retained on the front, with the front brake system from a '91 9000 mounted on the rear. Other stock Sonett components include the steering column, windshield, and the driver's seat. The battery and a 5-gallon fuel cell are located above the rear axle for better weight distribution.



Not the usual run to the grocery store

The rear tires are 12/29x15 Mickey Thompson slicks - that is 12 inches wide, by 29 inches tall on a 15 inch rim. The rear wheels are standard drag racer rims. The fronts are stock Sonett soccerball alloy wheels, with 195/55x15 radials. Dan says the brand isn't so important as the front tires are little more than rudders to keep the car in line on the dragstrip.

by Tim Winker

The Sonett races in the Import category, meaning it is usually up against Hondas and Toyotas as there are very few European cars built for drag racing. At the local track, Bandimere Speedway just west of Denver, the Sonett usually has to go up against domestic machinery, primarily Mustangs and Camaros, since there are few "import" drag cars in the Denver area. Consequently, the team has to travel to tracks farther west to find competition with four cylinder power, generally to exotic places like Las Vegas, Phoenix and Pomona, California.

Though Dan had someone else driving the car for him in the past, he has now taken on the task of driving in addition to being team owner, manager



The minimalist interior shares space with the tube frame.

and chief mechanic. After blowing up the engine in the first round at Las Vegas last year - due to incorrect ignition timing - Bollschweiler bought a 40 foot gooseneck trailer so he could carry spares such as engines and transmissions. That also provides an inside place to work on the car so repairs can be made if necessary.

As the Japanese cars have gotten quicker, so must the Sonett. Plans for this winter include considerable engine modifications such as work on the head for better flow, camshaft redesign and a larger turbocharger. In addition, Dan intends to add a nitrous oxide system, a popular method of increasing horsepower for the quarter mile.

Saab fans in the southeastern U.S., watch for this outrageous machine when the Import Drag races come to your town. It is definitely in the minority.

Photographs by the author.



Camelback
 Volkswagen SUBARU.



SAAB
FIND YOUR OWN ROAD

FACTORY TRAINED SAAB PARTS PROFESSIONALS – BEST IN THE BUSINESS

Why Advertise Specials –

ALL OUR PARTS ARE SPECIALLY PRICED

FREE FREIGHT ON FIRST ORDER
OVERNIGHT SHIPPING AVAILABLE

Call Mike , Al, Dave or Bill and find out first hand how much you can really save and put the profit back where it belongs

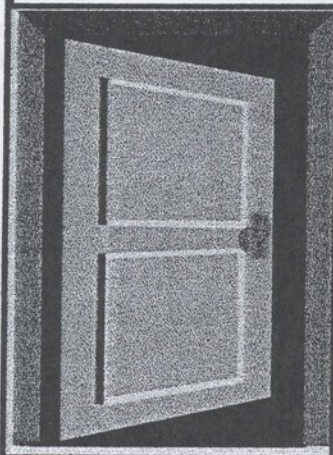

LET US HELP YOU TO OPEN THE DOOR TO A NEW WAY OF BUYING FACTORY REPLACEMENT PARTS AND ACCESSORIES FOR YOUR SAAB.

HOURS – Mon.-Fri. 7:00 AM til 5:30 PM
 Sat. 8:00 AM til 4:00 PM
 Times shown are Mountain Standard Time

“WE MAKE IT EASY”



WE ACCEPT

PHONE 1-800-876-5199 FAX 1-602-200-1192
 OR CONTACT OUR WEBSITE- [HTTP://WWW.CAMELBACKVW.COM](http://www.CAMELBACKVW.COM)

1499 East Camelback Road • Phoenix, Arizona 85014 • (602) 265-6600 • FAX: 263-9572



SAAB

SERVICE INFORMATION

SI No. **811-2156**

Date **July 1999**

900

PI No.

Distr. **US, CA**

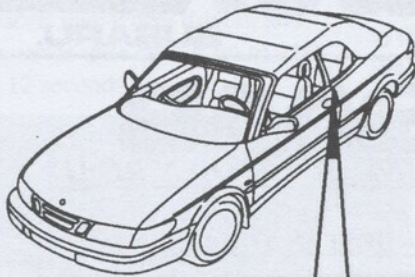

See disclaimer on following page.

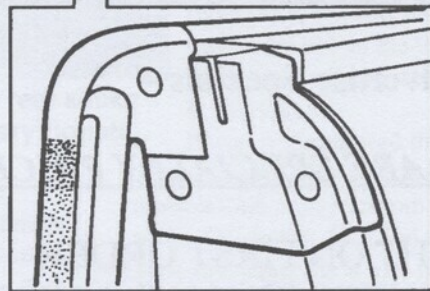

Cars affected

Saab 900 CV M95-M98

Note: SI No. 811-257, covering 9³ CV M99 up to VIN X7056813 is identical to SI No. 811-256 - Ed.

Background

On certain cars, especially if the weatherstrip between the door and the B-pillar is too short, irritating road and wind noise can penetrate into the cabin through the cover at the top of the B-pillar.

Customers may think that this noise is coming from the seal between the side glasses but it is actually coming around the bottom of the door.

By replacing the cover with one of a new design, the noise can be reduced while the fit and appearance is greatly enhanced.

Proceed with these measures after customer complaint. Both sides should be done at the same time.

Parts required

- 5112 776 Cover, LH (CA: 30581532)
- 5112 784 Cover, RH (CA: 30581533)
- 43 45 872 Plastic rivet (4 pcs) (CA: 30550549)

Procedure

Always perform this procedure on both the LH and RH B-pillars.

- 1 Open the door and lower the rear side window.
- 2 Remove the three plastic rivets.
- 3 Loosen the top of the door seal to

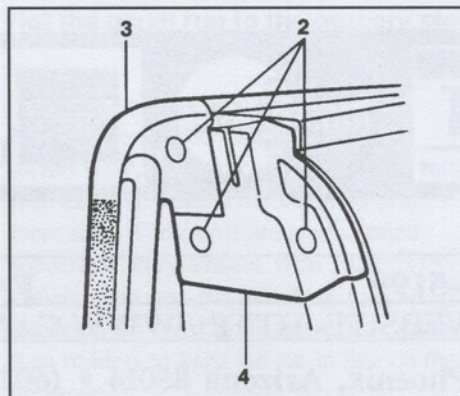

access the cover.

4 Remove the cover.

5 Carefully cut off the top of the door seal with a pair of scissors where the seal changes from a profile to flat, see illustration (just above the pebbled grain.)

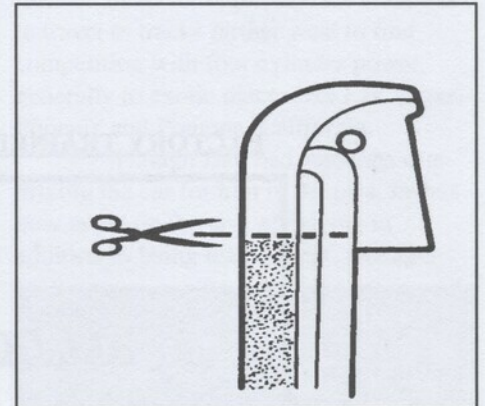

Important

If the door seal is cut too far down, the metal reinforcement in the seal will be exposed. If this is the case, the metal must be painted to protect it against corrosion.

6 Place a new cover on the B-pillar. Insert the cover from the side, making sure the metal hooks on the back of the cover fasten onto the B-pillar.

7 Fit two plastic rivets, part no. 43 45 872.

8 Check the function of the door and the rear side window.

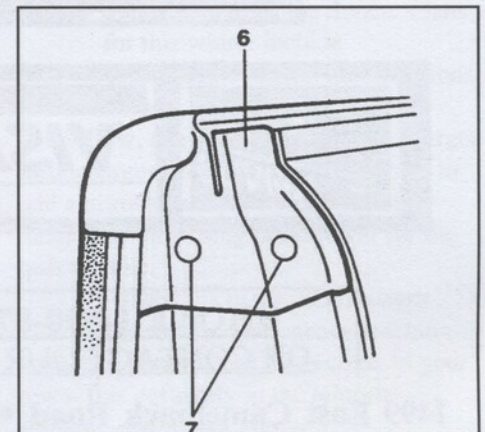



SAAB

SERVICE INFORMATION

SI No. **811-2099**

Date **July 1999**

900

PI No.

Distr. **all**

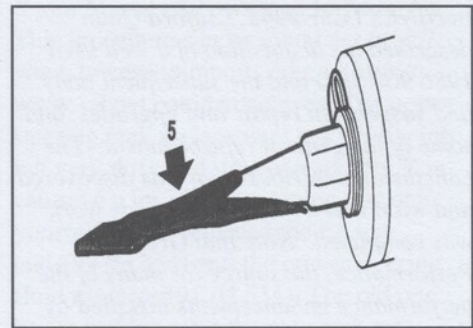
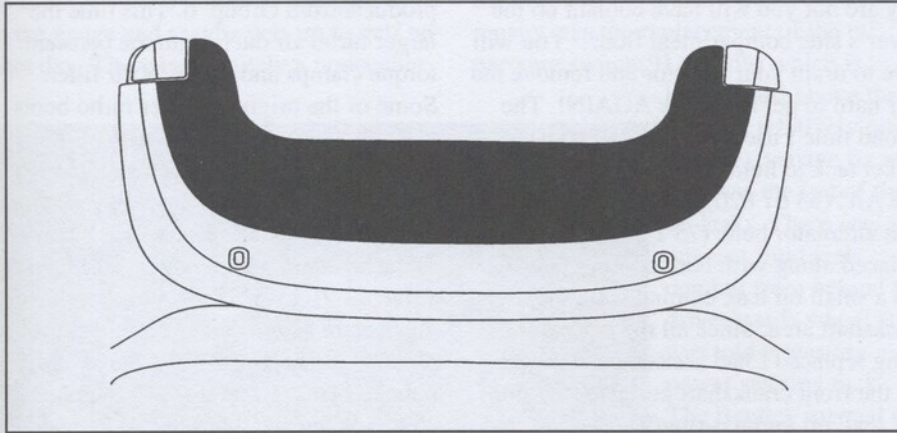

5 Take out the sealant. Make the opening of the nozzle smaller with adhesive tape so that it is easier to reach the bottom of the channel.

Cars affected

Saab 900 Convertible M95 - M98.

Note: Service Information SI No. 811-2094 with cars affected being Saab 9³ Convertible is otherwise identical to this Service Information Bulletin.

Parts required

4405007 Strip (CA: 30580924)
(16) 30 15 781 Teroson Terodicht sealant, black (T242) (CA: 30543815).

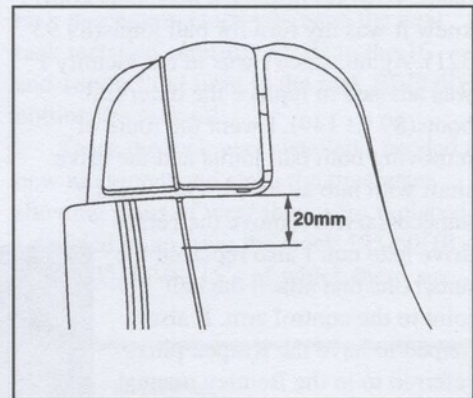

Procedure

- 1 Operate the soft top so that the cover is open (vertical).
- 2 Remove the cracked pieces of the foil seal.
- 3 Press the foil back into the retainer channel if it has come loose.
- 4 Remove old sealant from the retainer channel.

6 Apply sealant in the bottom of the channel. Start applying the sealant 20 mm from the channel opening and stop 20 mm from the end of the channel.

Background

There have been occasions when the foil strip on the soft-top cover of certain cars has cracked and separated in several places. This is most prominent in warm climates.

Replace the strip as described below after customer complaint.

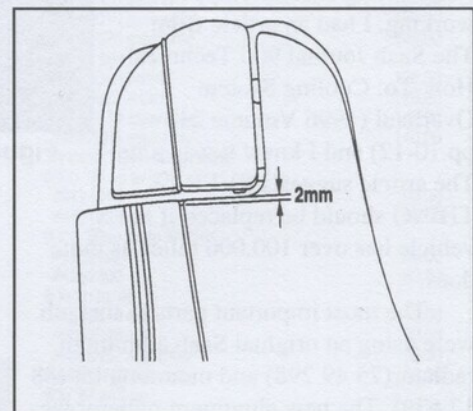

7 Fit the new strip. Start and finish 2 mm from the channel opening.

Saab Automobile AB Bulletins are intended for use by professional Saab technicians only, NOT a "do-it-yourselfer". They are designed to inform these technicians of conditions that may occur on some vehicles, or to provide information that could assist in the proper service of a vehicle. Saab trained technicians have the equipment, tools, safety instructions and know-how to do a job properly and safely. If a condition is described, DO NOT assume that the bulletin applies to your vehicle, or that your vehicle will have the condition. See your authorized Saab Dealer for information on whether your vehicle may benefit from the information.
© 1999 Saab Automobile AB All rights reserved

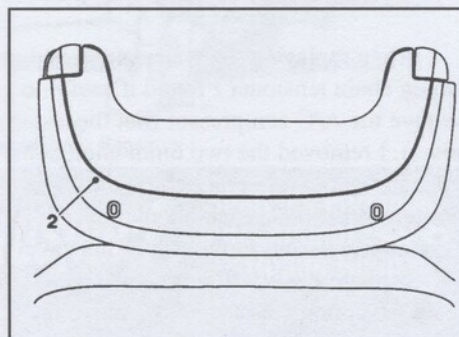

In NINES Issue #243, Clifford Quan described his acquisition of a well used 1986 900 SPG and the subsequent body and suspension repair and upgrades, and some of the general refurbishment. The conclusion describes what was discovered and what was done after the body work was completed. Note that Group 6 Performance, the source for many of the performance enhancements installed by Quan, is no longer doing business, but the products described in this article can be obtained from other NINES advertisers.

There was a bad clunk on the passenger's side when I took a sharp left turn, and from reading posts on TSN (The Saab Network, <http://www.saabnet.com>) I knew it was my turn for ball joints(89 93 321). Again, since I was in the vicinity I was advised to replace the outer CV boots(89 93 149). I went the route of removing both ball joints and the drive shaft with hub attached. This made it unnecessary to remove the center drive axle nut. I also replaced the nuts/bolts that attach the ball joint to the control arm. It also helped to have the Knipex pliers referred to in the Bentley manual for crimping down the CV boot clamps. The Knipex pliers were obtained from Snap On Tools .

This car ran hotter than I cared for. The temperature would typically be between one-half to three quarters and the right hand side cooling fan had stopped working. I had an article from The Saab Journal 900 Technical How-To: Cooling System Overhaul (1996 Volume 21, pp.10-12) and I knew it was time. The article suggests EVERYTHING should be replaced if the vehicle has over 100,000 miles as mine does.

The most important parts to this job were using an original Saab aluminum radiator(75 49 298) and mounting kit (88 17 579). The new aluminum radiator was about half the weight of the original. The water pump(88 17 900), 82°C thermo-stat(88 17 538), 82°C radiator fan switch(85 47 572), A/C thermo-contact(40 86 724) chain tensioner (75 85 086), expansion tank (75 49 876) and heater

valve(86 05 388) were replaced along with ALL hoses and clamps. Even the small bypass hose(75 04 624) and the metal pipe(93 32 826) in the top radiator hose were replaced. When replacing the heater control valve make sure that the two o-rings are seated in the grooves. If they are not you will have coolant on the driver's side compartment floor! You will have to drain your radiator and remove the four hard to get at screws AGAIN! The second time I used a small amount of gasket tack to hold the o-rings in place. The A/C (93 67 020), P/S(83 39 921), and both alternator belts (75 11 728) were also replaced along with both cooling fans. I had a small oil leak coming from the crankshaft area. Since all the belts were being replaced I had assistance in replacing the front crankshaft pulley(91 07 665) and seal, oil pump o-ring(91 25 824), and A/C idler pulley(41 18 964). After this the oil leak and whining noise from the A/C idler pulley were gone.

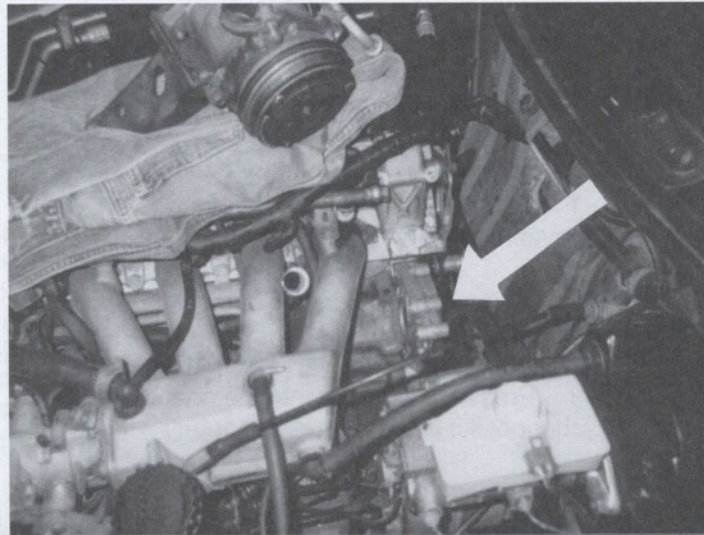

Figure 6: With A/C compressor placed out of the way, water pump housing is exposed.

When replacing the water pump and timing chain tensioner I found it useful to remove the A/C compressor (not the hoses). I removed the two 6mm allen bolts and a hidden 12mm bolt behind the alternator(this took a while) and placed the compressor out of the way. This gave full access to the water pump and timing chain tensioner. I was able to remove the old water pump and thoroughly clean both sides of the housing. Removing the 'old style' timing chain tensioner required a

27mm deep socket. To install the new tensioner first soak it in a quart of oil. Screw the new one in and tighten. Pull the wire out and tighten the center bolt. The tensioner is self adjusting.

Before final assembly of the cooling system I had purchased another round of products from Group 6. This time the larger turbo air ducts with the constant torque clamps and a K & N air filter. Some of the original rubber turbo boots were showing signs of wear so all four were replaced. There was also a large crack in the rubber boot(75 28 995) from the turbo to the air mass meter. It was replaced along with a new bypass valve(43 91 157). The Group 6 turbo air ducts were advertised as being yellow zinc plated but when I got them they were painted black. I was sort of disappointed so I had them sand blasted and powder coated silver!

My right hand side cooling fan was still not coming on when the car reached operating temperature. The classic test is to short the two wires at the thermo-contact(85 47 572) in the upper left hand corner of the radiator. This should turn the cooling fan on but mine did not come on. The fuse and fan relay in the fuse box had been replaced along with the new thermo-contact in the radiator. From the excellent advice of Thomas Townsend I was directed to a large black relay , Time Relay for the fan circuit, clipped to the inner fender well near the air filter. I had never noticed it before and it has two sets of numbers, 898271 and 85 87 677. You don't need this relay. Remove the relay(unplug it) and bridge connections 87 to 30(at the plug). The fan should come on whether the car is running or not. Clip the two wires(BE CAREFUL AND ONLY CLIP ONE AT A TIME) from the plug and solder them together and seal with heat shrink tubing. If you clip all the wires the power circuit will clip ground and blow the fuse. Leave wires 15 and 31 attached to the plug and tie the wire out of the way. My cooling fan now comes on when the car reaches just above half on the temperature gauge.

The radiator was filled with 50/50 Saab original coolant and distilled water. I also added the Red Line Water Wetter. One last thing I wired the cooling fans(SBJ 1996 Vol. 21) with the override switch so I can turn on both cooling fans at anytime. The cars temperature generally reads between one eighth to one quarter on the gauge and maybe gets up to half on a hot day. There is definitely a noticeable

improvement in acceleration with the Group6 ducts and K & N air filter.

As I began to drive the car regularly I noticed a few puddles of fluid still appearing on the garage floor each morning. I had gotten used to laying down newspaper or 'diapers' in order to locate the origin of the leaks. One of the easier repairs was the replacement of the oil pressure switch(91 12 459) which is

located just above the oil filter. A relatively quick and inexpensive fix and that was the last of the oil leaks. There was still one last fluid leak coming from behind the driver's side wheel and I was told it was my power steering rack. The Bentley manual is adequate in its description on replacing the power steering rack but an excellent supplement is the procedure of Thomas Townsend and

Ywan Mason of Townsend Imports, NC. This procedure can be found at : <http://www.townsendimports.com> or <http://www.sabnet.com/tsn/achives>. The power steering rack replacement is a doable job but very dirty and time consuming. You can save a lot of money doing this one yourself. I also replaced the tie rod ends(89 93 354) and the power steering fluid reservoir(91 04 555). The old one began leaking after the new rack was installed. The new style is one molded unit so there is no chance for the connections at the back of the reservoir to separate. It is black plastic and not transparent but there is a small dipstick attached to the cap to check the fluid level. I have only thing to add to the steering rack procedure. Once you have the new rack installed carefully screw in the 16 and 18mm fluid lines to the rack BEFORE bolting the rack in!

Once the rack was installed I needed a new alignment and since the tires were showing signs of wear they were replaced. I decided to go from the stock 195/60HR-15 to 205/55VR-15's of which there are

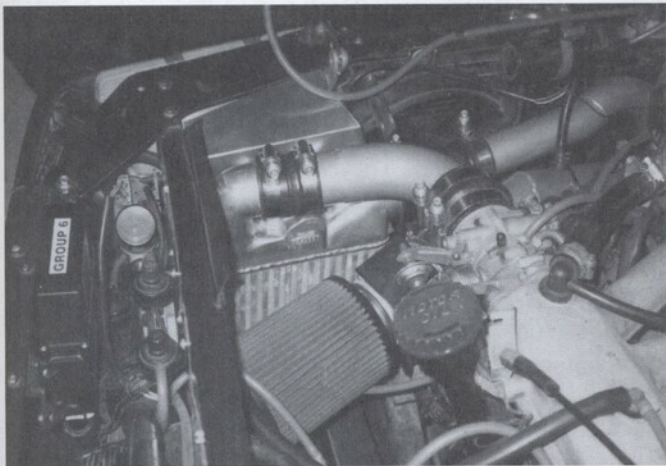
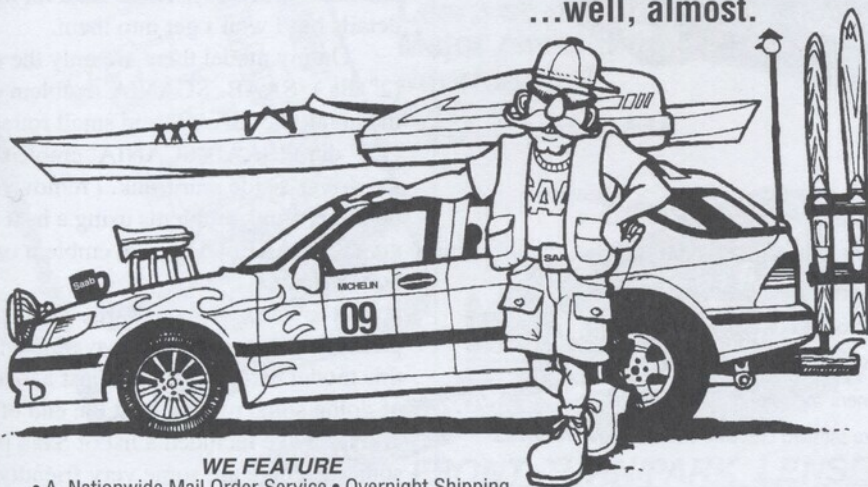

Figure 7: K&N Air cleaner, "Group 6" intake ducting and a pristine SPG engine compartment

Something for Everyone!

...well, almost.



WE FEATURE

- A Nationwide Mail Order Service • Overnight Shipping
- A Full Line of New & Used Parts • In-house SAAB Transmission Repair

Scanwest Autosport

Seattle's Foremost
Independent Saab
Repair Shop

888-90-TURBO (908-8726) Or (206) 789-2819 Fax (206) 781-5281

www.scanwestauto.com



9520 Greenwood Ave. N.
Seattle, WA 98103

9000 Headlights

9000 5dr up to '90	
#9122672 assembly	125.00
#9122680 assembly	125.00
9000 4dr up to '94 & 5dr '91 and newer	
#9521774 insert	125.00
#9521782 insert	125.00
900 5CS & 4dr '95 and newer	
#9084112 inserts	150.00
#9084120 inserts	150.00

900 Headlights

900 '87 to '90	
#9557018 inserts	80.00
#9557026 inserts	80.00
#9556010 assembly	125.00
#9556028 assembly	125.00
900 '91 and newer	
#4093019 inserts	125.00
#4093027 inserts	125.00
#4082870 assembly	140.00
#4082888 assembly	140.00

Front Turn Signals

9000 '90 up to '91	
#9121815	90.00
#9121823	90.00
9000 '89sn up to '91 5dr	
#4252292	80.00
#4252300	80.00
900 up to '86	
#8583510 lens	40.00
#8583528 lens	40.00
#8583452 assembly	80.00
#8583460 assembly	80.00
900 '87 and up	
#4014957	55.00
#4014965	55.00

Side Marker Lights

900 & 9000 #9124132	15.00
---------------------	-------

All parts carry a 12 month /12,000 mile warranty. If you don't see what you are looking for, give us a call. We stock a full selection of new and used parts for old and new SAABs. If we don't have it, we can probably tell you who does.

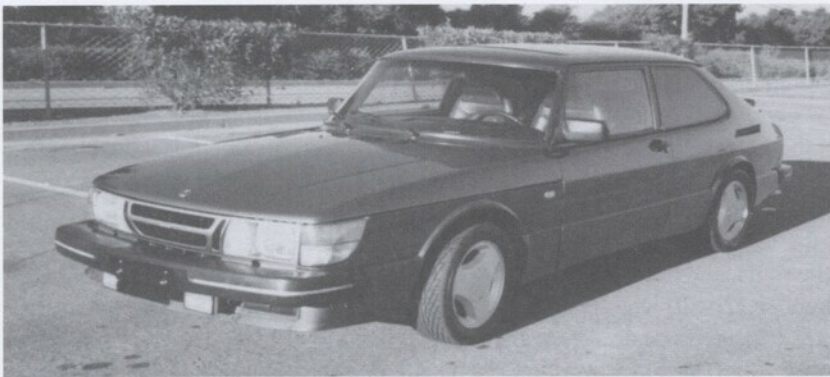
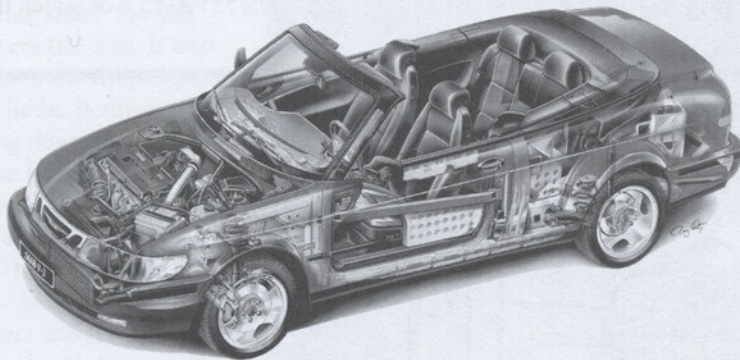

Figure 8: the end result - Clifford Quan's resurrected SPG.

**Need a reason to call
your Saab dealer for
replacement parts?**

Here's 23,565 of them!



Some aftermarket sources have some Saab replacement parts. Your authorized Saab dealer has access to over 20,000 genuine Saab parts. No other supplier can make that claim. Should your local Saab dealer not have that part on his shelf, it is available, usually within 24 hours through our computerized Parts Distribution Network. When you buy genuine Saab parts through your Saab dealer, you can be certain that every component meets original equipment specs. That will mean fewer comebacks, more satisfied customers and more profit.

As your authorized Saab dealer we can give you the quick one-source parts service you need. Protect your reputation and your customer's peace of mind. Use genuine Saab replacement parts.

Meyer Garage
SAAB IMPORTS
1-888-SAAB-2-GO * 515-737-2239



SAAB

many choices. I originally tried to get the Dunlop D40-M2's but they were discontinued so I decided to take a chance and purchased the Nitto NT-450's. These tires are great. They hug the road like glue. I have yet to test them in wet weather though. As far as performance tires, I've only owned the B.F. Goodrich Radial TA's in the past and I think the Nitto's are far superior. While I was having the tires mounted/balanced and the front end alignment I was informed by the tire shop that my rear passenger's rim was slightly bent.

I had been told that the SPG aluminum alloy three spoke wheels were difficult to find. This is the 5.5" X 15" aluminum rim made by Ronal (Saab 89 85 970) for my model the 1985-87 SPG turbo. I called the Ronal company in Huntington Beach CA and they said they could not obtain them. They were only available in Europe or through a Saab dealer. Through my investigations I found these rims to be available. Used ones ranged anywhere from \$110-\$125 each and new ones from \$160-\$185 each (hubcaps not included). My front passenger's rim had some surface scratches so I replaced both passenger's front and rear rims and hubcaps. I was able to have two rims mailed to my house with free shipping.

A few last details included a new front windshield, front license plate frame (powder coated), battery heat shield (85 94 897), mud flaps (82 89 266), chain guide (75 05 845), and power antenna (02 61 909). There are a lot more details but I won't get into them.

On my model there are only the round (2" dia.) 'SAAB-SCANIA' emblem on the hood, the 'SAAB' and small round (1.5" dia.) 'SAAB-SCANIA' emblem on the driver's side rear trunk. I removed both rear trunk emblems using a heat gun (BE CAREFUL!). The emblem on the hood remains.

A few words about parts. There are plenty of sources and parts available for this model and era Saab. Its just a matter of doing some research. At the end of this article I have included a list of Saab parts sources. There are some very friendly and knowledgeable people at these sources who are more than willing to help. I tried to use as many new original Saab parts as possible.

This has been one of the most intense projects I have ever undertaken. Was it worth it? Yes. The car is a pleasure to drive and own. It is definitely a driving enthusiasts car. Future upgrades will

include a Group 6 APC box and 2.8 Bar fuel pressure regulator.

I would especially like to thank the following people whom without their assistance this project would not have been possible: Mr. Andrew Braisted for mechanical assistance and guidance; Mr. Shane Turner (Assistant Parts Manager) of Burlingame Saab, CA for assistance on parts; Mr. Thomas Townsend of Townsend Imports, NC for his patience and valuable technical advice; my wife Cindi for enduring the last fourteen months.

All-Car Auto Body
501 Ninth Ave.
San Mateo, CA
(415) 343-5624

Alpha Parts Exchange
2000 National Ave.
Hayward, CA 94545
(510) 782-5800

Andrews Inc. Of Princeton
3558 Brickton Rd.
Princeton, MN 55371
(800) 882-7220
www.andrewsofprinceton.com/

B & B Saab
2983 El Camino
Santa Clara, CA 95051
(408) 246-6388
www.bbsaab.com/

Burlingame Saab
825 N. San Mateo Dr.
San Mateo, CA
(650) 348-4200
www.burlingamesaab.com

Import Parts Specialists, Inc
2212 West Main St.
Boise, ID 83702
(800) 897-7278
www.importpartsspec.com

Saab Auto Dismantlers
3539 Recycle Rd.
Rancho Cordova, CA 95742
(916) 635-9970

Sweden Auto Warehouse
8516-A Fruitridge Rd.
Sacramento, CA 95826
(916) 387-6892

Swedish Auto Specialties
P.O. Box 325
Eagle Creek, OR 97022
(503) 630-7222
www.sasab.com

Townsend Imports
2229B West Lee St.
Greensboro, NC 27403
(336) 292-4170
www.saabnet.com/tsn/ad/townsendimports.html

Trollhattan Auto Parts, Inc
813 Eastern Blvd. Suite#102
Baltimore, MD 21221
(410) 682-2827
www.cybertroll.com/

Note: While Group 6 is no longer in business, many of the "Group 6" components used by Mr. Quan are available from NINES advertisers. -Ed.

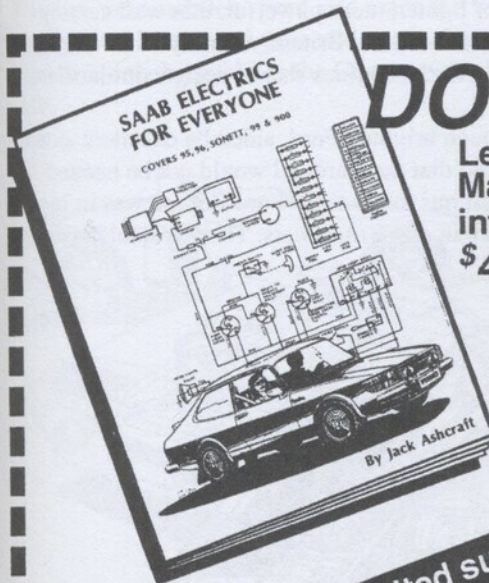

DO IT THE RIGHT WAY!

Learn all about your V4 electrical system!
Major circuits covered in detail. 100 pages of great information!

\$45.00 plus \$5 S&H

Only 2 left!



**RARE SONETT
BRAKE MASTER CYLINDERS**

New old stock **\$349.00** plus shipping
They won't last long at this price!

Limited supply!

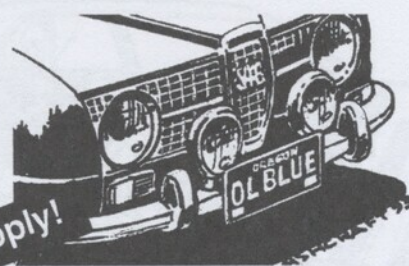

FRONT TURN/PARK LENSES \$ 39.00 each plus shipping
New old stock, fits 1965-68 95's & 96's



Jack Ashcraft's
ORPHAN SAAB V4 PARTS

Ph 541-779-0731 Fax 541-779-0788
email: jackashcraft@prodigy.net
4305 Dark Hollow Rd, Medford OR 97501

FREE CATALOG!

The V4 Ford Engine - A Short History

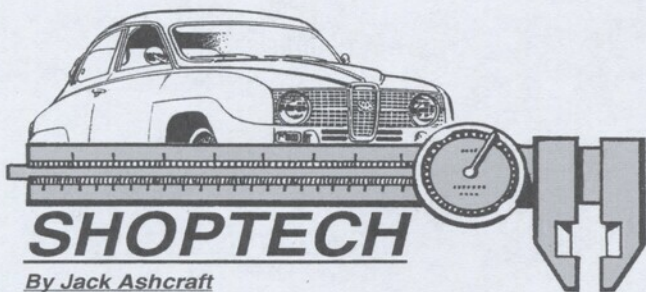

By Jack Ashcraft

Ford was running scared. Ford's 1958 sales of only 987,945 (1) units was their lowest in years. Volkswagen, Renault, Fiat, Volvo and a phalanx of British cars had posted collective USA sales of over a quarter million (2). Rambler, together with Metropolitan, had sold just over 217,000 cars (3). The small car handwriting was on the wall.

Ford knew GM and Chrysler were working hard on Rambler-sized compact cars. Ford clearly saw TWO adversaries—the domestic compacts like Lark, Rambler and the up-coming Corvair and Valiant; and the imported sub-compacts led by Volkswagen. Ford's advanced vehicle engineers proceeded at an almost feverish pace on THREE entirely different cars. One was code named "XK-Thunderbird" (4), a compact sedan that saw production as the 1960 Falcon. No. two was code named "T-5" (5) and was the Mustang I. No. 3 was code named Cardinal, and was a sub-compact with a V4 engine and front wheel drive (6).

Ford's engine design people were not idle during this time either. A whole new line of lighter, more powerful, thin wall casting engines was being developed. In Dearborn, a family of V8's and in-line 6's was being tested. In Great Britain, a family of V4 and V6 engines were being developed under the watchful eye of chief engineer Carlo Raviolo (7). All the engines shared design similarities, and there were many interchangeable parts across the line.

By 1961, Rambler was third OVERALL in USA sales (8) but Ford's fortunes were much brighter. Ford, aided by excellent sales of the Falcon, edged out Chevrolet to move into the No. 1 sales spot for the year. Convinced that the Cardinal would not be needed in the USA, Ford shipped the car—lock, stock and hubcaps—to West Germany. It was a fortuitous move since Ford Europe was in big sales trouble. Their old Taunus models were being killed in the marketplace by French, Italian and British cars. The Cardinal became the new German Ford Taunus.

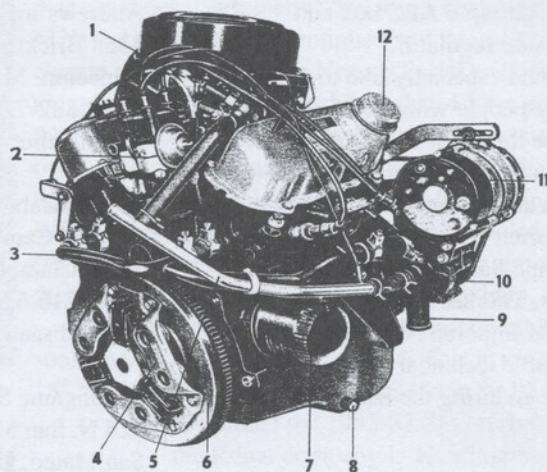

Early V4 Engine

- | | |
|------------------|----------------------------------|
| 1-Carburetor | 7-Oil Filter |
| 2-Distributor | 8-Oil Drain Plug |
| 3-Coolant Pipe | 9-Coolant Outlet from Water Pump |
| 4-Pressure Plate | 10-Water Pump |
| 5-Coolant Pipe | 11-Alternator |
| 6-Flywheel | 12-Oil Filter Cap |

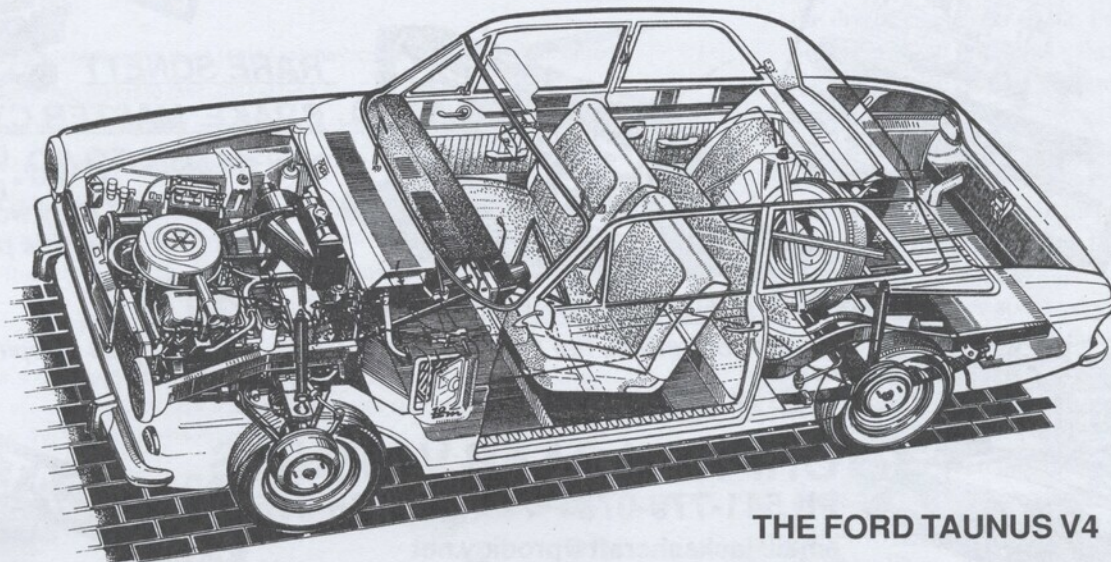

THE FORD TAUNUS V4

It is interesting to note that the British Ford V4 engine—the so-called Essex unit— was almost entirely different from the V4 built in Cologne. Opinion differs about the relative merits of the two engine lines, but there was no doubt in Saab engineers minds—the Cologne unit was clearly the superior engine. Even then, the engine purchase agreement with Ford Cologne was conditional on Ford revising the V4 engine somewhat. Saab's chief engineer Rolf Melde insisted on a change from open to closed deck engine blocks, positive crankcase ventilation and improved carburetor to control emissions, and other, more minor improvements.

Also in 1961, the T-5 group had been given the go-ahead by Chairman Lee Iacocca to develop a "sporty" car for Ford, to compete in the Jaguar-Corvette market. Time, as usual, was of the essence, so the Gene Bordinat designed Mustang I was built—under Ford direction—at the Troutman & Barnes custom body shop in Los Angeles. Herb Misch and Roy Lunn designed the chassis. T & B built the very pretty aluminum bodies and the Mustang I—powered by a 1527cc (90mm x 60mm bore & stroke) V4 engine—was first shown to the public at the United States Grand Prix at Watkins Glen in October, 1962. The gearbox used was the 4 speed Taunus unit (9).

By 1962 enough V4's were in service to prove their reliability. Ford began to offer the engine in a variety of stationary power plant applications, including use as irrigation water pumps and electric generators. Ford supplied V4 engines to Thiokol Chemical Co in Utah for use in Thiokol snowmobiles. Ford also made the V4 engine available to Matra, and their mid-engine M530A model was introduced to the public at the Geneva auto show in 1967 (10).

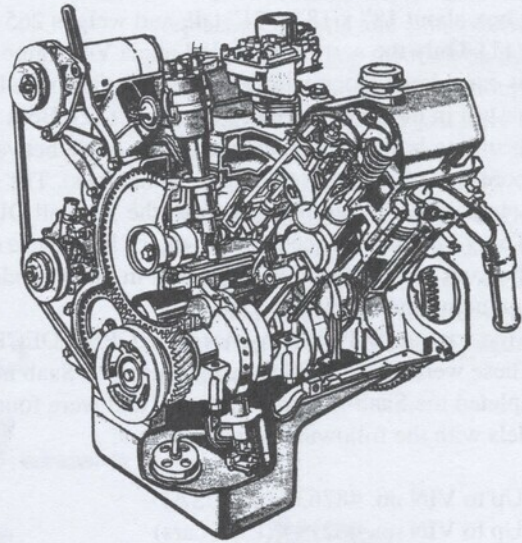

**THE BRITISH FORD V4 -
THE "ESSEX" UNIT.**

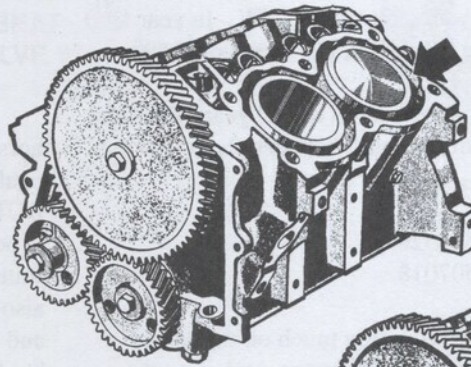

OPEN DECK BLOCK

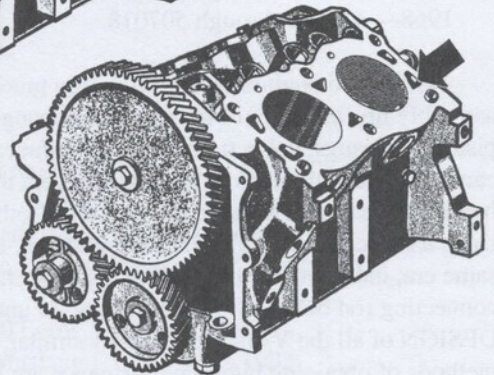

CLOSED DECK BLOCK

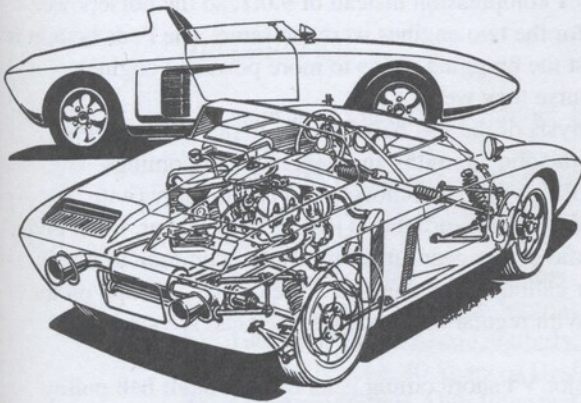

THE MUSTANG 1

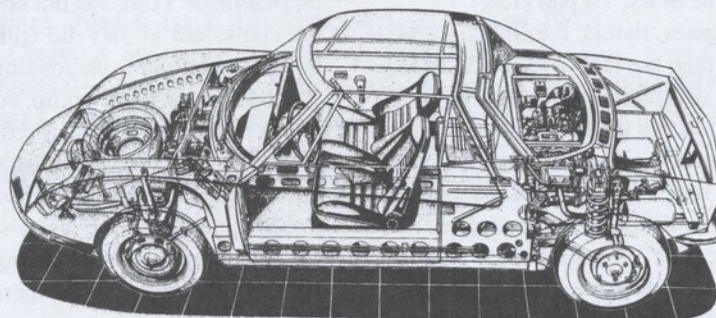

MATRA 530A

The V4 Ford Engine - A Short History

The V4 engine is extremely compact. It will fit—ready to run—in a box about 18" x 18" x 21" tall, and weighs 265 LB (120 kg) (11). Only the narrow V-angle Lancia V4 engine—which was considered along with a number of other small engines for use in the 96—was more compact (12). Both the V4 and its V6 sibling have an included angle (the angle between the cylinder bores) of 60 degrees (V8's use 90 degrees). The six is inherently in balance in this configuration, the V4 well OUT of balance. The V4 is put into acceptable balance by the use of a balance shaft, an item in common use today in many modern engines, including those built by Saab.

The first contract V4 Ford engines were OPEN DECK block casting. These were silver 1498cc engines used by Saab until Ford completed the Saab-required upgrades and were found in Saab models with the following serial numbers:

- 96— Up to VIN no. 487638 (not USA)
- 96— Up to VIN no. 482197 (USA cars)
- 95— Up to VIN no. 55766 (not USA)
- 95— Up to VIN no. 54854 (USA cars)
- 97— Up to Vin no. 000510 except for 504, 505 and 506

AFTER these VIN numbers, Saab used the Ford 1498cc CLOSED DECK, blue engines through year model 1969. In year model 1970, the 1498cc V4s were painted BLACK. In year model 1971, the engines were still black, but were now 1698cc displacement (12).

Monte Carlo V4 models were built in model years 1967 and 1968. They were selected from cars built between the following VIN numbers:

- 1967— 420001 through 458526
- 1968— 470001 through 507018

V4 and V6 engines were built pretty much on the same assembly line and a lot of the parts interchange, including the pistons and rings, valve train (except for the camshaft), oil pump, camshaft and main and rod bearings (except that the V6 has more bearings), seals and some of the gaskets. Both the V4 and V6 share a few components with the small block Ford V8s of the same era, including the cam followers (tappets) and the connecting rod bolts (5/16"). It IS good to understand that the DESIGN of all the V-engines are very similar, so, for example, methods of obtaining higher performance are the same for all the V-engines. The G-Force oil pan modification done to my 68 Sonett autocross car is based on the same item used in the Trans AM Mustangs, but scaled down to fit the V4 pan (13).

These are "over-square" engines, that is, the BORE (3.54"—the same on both V4's) is larger than the length of the STROKE (2.32" on 1498cc engines, 2.63" on 1698cc engines). The net result is that while the engines must rev a good bit higher at highway speeds than current, similarly sized engines, they still are quite durable so long as they receive regular oil and filter changes (using synthetic oil) and have their valves adjusted every 6000 miles. We always considered the V4 engine to be a good 100,000 mile unit. Many go much farther than that; neglected engines a good bit less.

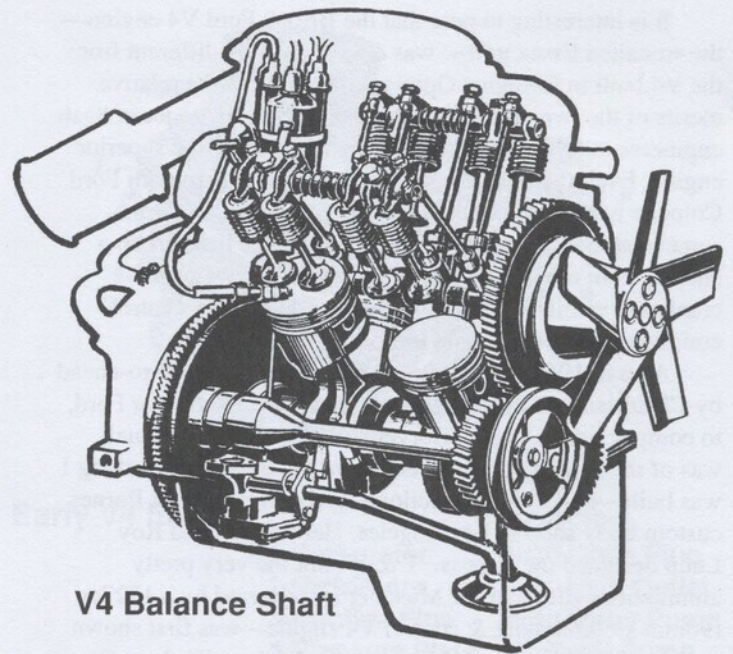

V4 Balance Shaft

Saab rated the 1498cc V4 engines at 65 DIN (73 SAE) horsepower. When the 1698cc engine was installed in 1971, Saab could have rated the larger engine at about 70 DIN (80 SAE) bhp. BUT—they would have had to go through the ridiculous and expensive USA engine certification process. Instead, they merely stated that although the engine had 200cc more displacement, it also had 8.0:1 compression instead of 9.0:1, so the horsepower and torque for the two engines were the same. The Feds bought it but Saab lost the bragging rights to more powerful engines, which of course they were.

An analysis of the V4, based on the luxury of hindsight, indicates both solid strengths and nagging shortcomings. The engines are tough little workhorses that can reliably (with suitable modifications) produce 110-115 horsepower. Even given the fairly unfavorable gear ratios, it is not uncommon to obtain 30 miles per gallon with a Saab 96 driven at say, 70 mph on the open road. With regular maintenance, they can see six figure mileage.

The major V4 shortcoming is its balance shaft belt pulley arrangement. Ford was not content to leave the drive pulley on the crankshaft as they did with the V6. Putting the pulley on the balance shaft puts side loading on the balance shaft bearings and the load of the water pump, cooling fan and alternator on the (stock) phenolic balance shaft gear. Predictably, the phenolic gear is the first thing to fail in these engines, all other things being equal. Replacement gears first were nylon, which was some improvement. Steel balance shaft gears are the real answer, and the current replacement timing gear sets from Saab have steel balance shaft gears. Took them a while, but they finally got it right.

Unleaded gasoline is death on exhaust valves of stock V4 engines. Happily enough, it is no big problem for a good machine shop to install hardened exhaust valves and valve seats in the V4 cylinder heads (which, by the way, are interchangeable side-to-side on the engine). The carburetors—either Solex (through 1968) or FoMoCo—are now old in the tooth and subject to wear, age and warpage. Again, an excellent replacement is available in the 34 series Weber one barrel carburetor, which bolts on with only small modifications.

For performance buffs the cylinder heads are very restrictive, on both the intake and exhaust sides. The intake manifold is no help either. All of these things can be resolved if your bank account will stand the shock. Saab were able to extract something on the order of 165 bhp (14) from their final version rally engine, but they were still giving away close to 100 horsepower and even the formidable talents of Stig Blomquist and Simo Makinen were not enough to keep Saab competitive in international rallying. That, though, is another story.

CYLINDER HEAD PARTS

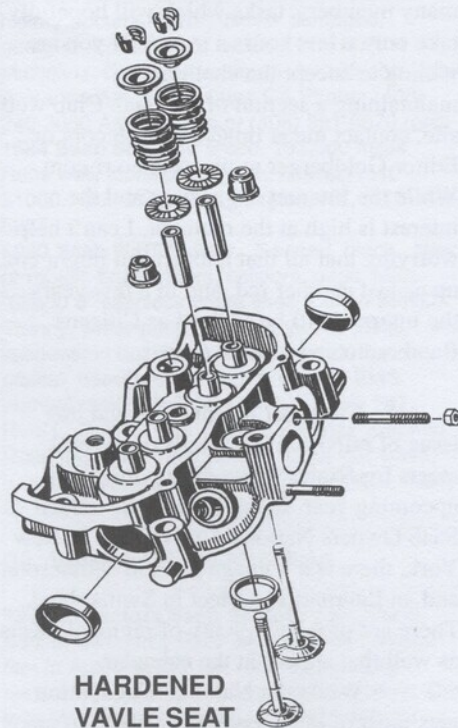

HARDENED VALVE SEAT AND VALVE

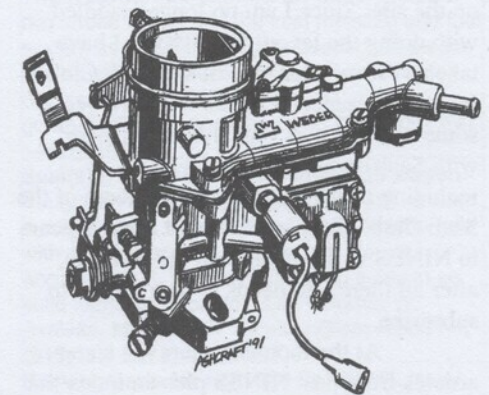

WEBER 34 ICH CARBURETOR

REFERENCES:

- 1) Consumer Guide Auto Editors, Encyclopedia of American Cars, Model Year Production, page 808, 1993.
- 2) James M Flammang, Volkswagens, Beetles, Busses & Beyond, Retail Sales, page 235, 1996.
- 3) James T Bradley & Richard M Langworth, The American Car Since 1775, Calendar Year Production, page 142, 1971.
- 4) Consumers Guide Auto Editors, Ford—The Complete History, 1960 Fords, page 230, 1990.
- 5) Jack Ashcraft, The Saab Journal, Vol. 15, Opportunity Lost—The Mustang I, page 10-13, 1995.
- 6) Harvey B Janes, Auto Quarterly, Vol. 1, No. 4, Front Wheel Drive, page 279, 1962.
- 7) Dante Giacosa, 40 Years of Design With Fiat, The 103 Project, page 130, 1979.
- 8) Consumer Guide Auto Editors, Cars Of The 60's, Model Year Production, page 65, 1979.
- 9) Gordon H Jennings, Road & Track, The Mustang, page 69, Nov 1962.
- 10) Eric Dymock, Classic & Sportscars, Matra, page 151, 1981.
- 11) Saab Service Manual—Saab 95, 96 & Monte Carlo, Section O, page 0 20:1, 1975.
- 12) Saab Spare Parts Catalog—Saab 95, 96 & Monte Carlo, Section O, page 0 3:1 and Section 2, pages 2 1:2 and 2 4:3, 1973.
- 13) Jack Ashcraft, The Total Performance V4, Building A G-Force Oil Pan, page 27, 1999.
- 14) Anders Tunberg, From 2-Stroke to Turbo, page 86, 1980.

Over the past few years, my column in this publication has mentioned the growth of the Internet and the Saab Club's presence within this rapidly growing medium. As my interest in publishing for the World Wide Web grew and my interest in the printed page waned, I have pressed on with learning the ways to design pages for display on the Cathode Ray Tube. Toward that end I have spent considerable time over the past few months translating information published in NINES into web pages. The Saab Club web site was established just over two years ago, with help from members Chris Rogers and John Steiner. However, neither really had the time to keep up with what I wanted to see on the site. Since I am no longer saddled with doing the layout for NINES, I have taken over maintenance of the Saab Club's Internet presence. Visitors will now see some of the things I had hoped to share with Saab owners via the web site, including those who are not members of the Saab Club. Only a fraction of what appears in NINES will be found on the web site, after all there still needs to be a reason to subscribe.

At the moment, there are some articles from past NINES plus an index that goes back nearly ten years. More of the same will appear in the next few months. One recent addition is a search engine, so that visitors may locate something published in NINES on a particular subject. One early user of the search feature, however, found that there is nothing to be found when seeking information on a "Sonnet". Hopefully by the time this issue arrives in your hands, there will be a "Registry" section, where Saab owners, whether members or not, will be able to let other owners know about their cars. Initially it will be limited to Saabs 20 years and older, then will add some of the special models such as the 99 Turbo, 900 SPG and the 9000 Aero. Eventually it will be expanded to include all Saabs.

One thing that Editor Goldberger and I both would like to see is a Members Only section, where Saab Club members will be able to access information not available to the public at large, such as the Mechanics List. This probably won't be happening soon as there are other plans that take precedence. While these are all great ideas, they will take a lot of work, and not many people are willing to take on such a

task without compensation. The alternative is to spread smaller assignments among many members, tasks which will hopefully take only a few hours a month. If you are willing to accept the challenge of maintaining a section of the Saab Club web site, contact me at tim@saabclub.com or Editor Goldberger at nines@neo.rr.com. While the Internet is growing and the interest is high at the moment, I can't help worrying that all that enthusiasm might end up as just another fad, and in a few years the Internet will be as dead as Citizens Band radio and 8-track tapes.

The most recent issue and this issue of NINES have details on several meets for Saab owners during the upcoming year. In addition to the annual Saab Owners National Convention in New York, there is a Vintage meet in Minnesota, and an International Meet in Switzerland. There are probably plenty of regional meets as well that appear in the calendar.

While the National Convention gets most of the press, I have come to enjoy the smaller, regional meets. There may be fewer cars and less to do, but that's an advantage. You can spend more time looking at the cars and visiting with their owners. One of my favorite meets in the past few years has been the annual Open House at Andrews in Princeton, Minnesota. That it is close to home is one advantage, but it's also a chance to visit with friends in the Saab community. There is, of course, a car show, and usually a tech session or two, a swap of used parts, and new parts at a discount. In recent years, Marty and Annette Adams of Meyer Garage in Iowa have brought a few new models for visitors to drive.

The Adams clan has added a similar Open House in September for the past few years, and it, too, has become an annual tradition for me. The Andrews folks make the trip down to Meyer, Iowa, as do many other folks who work on Saabs for a living. It's very likely that you will see Tom Donney, Jim and Jay Iverson, and the Walkers from Des Moines at both the Andrews and Meyer Garage meets. There is a definite camaraderie among these independent Saab repair folks. They all are in the business out of an admiration for the Saab marque.

So who's missing? Most Saab dealers. Marty and Annette are in the

minority as owners of a Saab dealership who actively participate with Saab owners outside of the daily business. Only a few dealerships try to cultivate the business of the Saab enthusiast. On the other hand, the majority of Saab independents seem to be active socially with Saab owners. While I know of a dozen or so Saab dealerships that do cater to the Saab fanatic, and many of those advertise in NINES, that is still only about five percent of the total number of franchised dealers.

Getting back to the Andrews Open House for a moment, there are two Saab dealerships in Minneapolis and St. Paul that are much closer to Princeton than is Meyer Garage. While they are perfectly welcome to participate, and have been invited to functions of the Minnesota Saab Club, the attitude of these dealerships is downright hostile toward the clubs and the independent Saab shops. This makes absolutely no sense to me. The independent shops need to buy parts and tools somewhere, why not work on increasing the wholesale business? Felix Bosshard, owner of Charles River Saab in Massachusetts realizes this; his dealership is consistently one of the top wholesalers of Saab parts in the country.

A member of a marque club is one of the most enthusiastic sales referrals a dealership could have, so why not cultivate that relationship? Saab Cars USA realizes this and has gotten actively involved with the Saab Clubs over the past ten years or so. The folks at Saab have tried to instill this idea into the dealer group, but there still aren't enough who try to get more involved with the owners.

Over the past 15 years, while traveling to or from Saab meets, I often stop at Saab dealerships and independent shops just to visit. Most independents have been quite friendly, taking a few minutes from their day to chat and show me around their place of business. Too many dealerships, on the other hand, have treated me as though I was wasting their time and could not seem to get rid of me quickly enough.

As mentioned above, there are exceptions to both cases, but not very many. If these dealerships treat their customers the same way I was treated, those Saab owners may well prefer to take their business to an independent repair shop.

Saab Swap

95, 9000 For Sale

1999 95SE V6, 4 door, Auto, Traction Control, Alloys, Pwr Sunroof, Pwr/heated seats, cruise control, Side Air Bags, Stereo Cassette w/CD, Only 5K miles, Blue/Tan Leather, \$26,900. Imports Unlimited, www.luxurycars.com (203) 284-8989

1999 Saab 95 2.3t w/stick shift for sale - 15.5k miles. Perfect condition. Charcoal leather interior, moonroof, dual zone climate control, etc. \$30,500 obo. Reason for sale: upgrading to Aero. Tamir Orbach, Rockville MD orbacht@science-management.com (301) 529-6931

1991 Saab 9000 Turbo. Standard, 86,000, Grey w/Grey Leather. Ungo security, w/remote, Sony CDXC6750 Cd, cerwin vega speakers. pre-wired for amp. Almost everything replaced except turbo, transmission, and engine. Interior is almost flawless - always 93 octane. Service by Saab Master Techs. second owner. \$9,000 OBO. TSN Michael Killigrew, Wellesley MA mkk5@lehigh.edu (781) 235-5274

93, 900 For Sale

1999 93 Turbo Convertible 5-sp, Pwr/top, Pwr/doorlocks, Pwr/windows, Heated Seats, Alloys, Side Air Bags, BS brakes, Cruise Control, Stereo Cassette, only 13K miles, Blue/Tan Leather, \$25,900. Imports Unlimited, www.luxurycars.com (203) 284-8989

1999 93 SE Turbo Auto, 5-door, Pwr/Sunroof, Pwr/heated seats, Alloys, Traction Control, Side Air Bags, Stereo W/CD, 22K miles, Green/Tan Leather, \$22,900. Imports Unlimited, www.luxurycars.com (203) 284-8989

1996 900 SE Turbo Convertible Auto, Pwr / Roof, Pwr/heated seats, Alloys, Dual Air Bags, ABS Brakes, 44K miles, Blac/Black Leather \$19,900. Imports Unlimited, www.luxurycars.com (203) 284-8989

1995 900 SE Convertible, V6 automatic, red, sport trans, loaded w/ every option, service records, 100,000 miles. \$13,900, possible delivery. Dan Marlett, Dallas, TX. (214) 505-8719 or (972) 539-9885

1992 900s 5-speed manual, black and tan, excellent condition, original owner, complete maintenance records. 125,000 mostly highway miles, all work by top notch mechanic. \$7000. David, Detroit, MI 313-882-5857

1989 Saab 900 Turbo Convertible, 81,000 miles. Well Maintained, 2nd Owner, Loaded with EXTRAS!!!! Black /Tan, Leather interior, Power everything, 5-speed. New Paint, New Top, Alpine 6 Disc CD Denon 120 watt am and Quart speakers \$450.00, New Yokohamaand ROH Mags \$650.00, Rebuilt trans, New AC, Power Steering Rack, 8,995. TSN Matthew Nelson, Atlanta, GA cmatthewnelson@mindspring.com Phone: (404) 502-5502

1988 Saab 900 Turbo, black, 3dr, standard, 116,000 miles. Only owner. All scheduled maintenance performed. Inherited a car and Saab must go. Needs a little work, sell cheap. \$2,250 Doug Burbank, Mandeville LA aburbank@bellsouth.net Phone: (504) 624-9064

1984 Saab 900 Turbo, 5dr, silver, automatic, 193k miles. Original owner pampered and loved car! Cell phone (analog).. Complete service history documentation. Never damaged, garaged. Epsilon 3 pc. wheels with MXV 4 Michelins. Cover. New stereo. \$3,195/obo. John A. VanderAar, Santa Clara CA Phone: (408) 246-3050 Ask for John or (408) 891-8670 (cell)

1984 Saab 900 4-dr, 5-sp, 193,000 miles. Runs well, looks great, early chassis rust. \$1000. David Brief, Huntington, NY, (516) 427-5837

1980 Saab 900T 3-door. 5-speed, black. New or rebuilt: brake rotors, calipers, pads, M/C, "Group 6" stainless brake lines, Clutch & M/C, Tranny, water pump, fuel pump, ball joints, suspension bushings, motor mounts, head gasket, headliner, all with "0 miles". EMS manual rack. Straight, solid body with NO RUST. Buy for cost of parts - \$2100. Stephen Goldberger, N. Canton, OH. (330) 497-0346, Email: nines@neo.rr.com, or Jim Phillips, (330) 376-3003.

99, Sonett, 96, 95 For Sale

1977 Ex-factory Saab 99 Rally Car (black). Built at Sweden's Race and Rally for competition in Australia and SE Asia. Completely restored and ready to use in Historic rallies. Car is in Melbourne Australia. AUD\$20,000. Dr William Cartwright, Windsor, Victoria AUSTRALIA Email: william.cartwright@rmit.edu.au Phone: +61 3 9510 3346

1974 Sonett Blue, wife's dail driver '74-'95, low mileage, freewheel still works, some rust in pan & old scar on driver's side front wheel well; complete set of SAAB special tools, shop manuals, and many extra parts - \$5000. Dwight Benecke, Cherry Hill, NJ, (856) 667-5842 between 8pm and 10pm Eastern Time.

Silversand 1970 96V4. Nice interior and exterior and NO RUST. I did brake, clutch, carburetor, and much TLC work, but the V4 is tired. Buyer gets a good, complete '68 Sonett V4 engine with the car. \$1500 for all. Jack Ashcraft, 4305 Dark Hollow Road, Medford, OR 97501. Phone/Fax (541) 779-0731

1969 SAAB 95, Driven Daily. Good project car. Over \$6500.00 in factory parts, many extra used parts. List by part number available. All for \$4500.00 OBO. Tom L Brain (253) 874-4509 or TLBrain@aol.com

Parts and Misc. For Sale

Parting out Saabs: '84 900, 85 900T, 86 900 Base, 86 900 SPG, 87 900T 16V, 89 900S 16V, 94-98 900, 900S, 900T. Drivetrains, Interiors, Body Parts, Suspension, Wheels, Misc. Parts & Accessories. Dave Anelli, Walingford, CT. 203-949-4881.

Brand new 17 in 9-5 Aero wheels, original Saab 3-spoke. The stock wheels supplied with a 2000 9-5 Aero. Tires not included. \$750/set of four. Available mid February. FOB Portland, OR Randall Vogt, Portland OR vogt4me@aol.com (503) 228-9858 X14

Manual boost controllers, fastest spooling on market, rock steady boost control, fits all turbo models, complete kit inc. instructions, easy adj, inst., unbelievable boost \$75 shipped (COD \$5 extra) Curt Brown, Sewickley PA Email: cbre@home.com Phone: (412) 741-0363

We can supply new shocks for Saab from 1956 through 1993. We also rebuild lever shocks on early Saabs. Five Points Classic Auto Shocks, 2911A South Main, Sanda Ana, CA 92707, (714) 979-0451

Wanted

Wanted - Sonetts and 96s, Run/not, 6 sons & I having fun, Accident/Damage/Flood/ Totaled/ Parts Cars, OK Leave Info.; Yr., Trani, Miles, Maint., Etc. John T. Jacobson, Appleton WI Email: Saab46son@aol.com Phone: (920) 954-8864 fax 8847

Triple carburetor wanted for Saab Sonett II two stroke model and the inlet manifold and fuel system as well. I'm living in Sweden, so please use email to contact me or fax Goran Dahlen, Stocksund SWEDEN Email:

goran.dahlen@swipnet.se +46708809007 Fax: +46706101087

Seat(s) with headrests for model 95 wagon. Bought a 1967 wagon, daughter wants at least a driver's seat with read restraints. Include rails with seat in case the present rails do not accomodate it. Will be re-covering seats in so solid foam but poor cloth OK. Robert W. Avakian, Midland TX ravakian@apex2000.net (915) 694-2271

Seeking parts for my 1968 Sonett V4. Need nice hubcaps, a pair of taillight lenses, a choice set of door handles. Any parts cars or spares available? Have scads of Sonett III parts for trading. Peter Sliskovich, San Pedro CA coupeking@aol.com (310) 519-7554

Desperately Seeking alloy wheel center caps, part # 91002492 (old #) or 02 70 108 (new #) to fit several optional "Super Inca" Saab Alloys. Pedro Tai, Parkdale, OR (541) 352-6611

Wanted Old rally timing equipment: Heuer stopwatches + wristwatches; (Montecarlo, Mastertime, Sebring, Autorally, Super Autavia, Etc.) Halda Speedpilot, Dtwinmaster, Tripmaster, 3 stopwatch clipboard, Curta Calculator, Judson/Shorrock Supercharger. Macgoodies@aol.com. Castle, Box 2030, Redondo Beach, CA 90278, USA. (310) 793-0129

Sponsors Wanted for Saab Sonett Vintage Racers: Roll Cage, Fuel & Systems, Engines, Trans, Brakes, Wheels, Tires, Ignition, Battery, Exhaust, Fire Suit, Gloves, Shoes, Extinguisher, Helmet, Trailer, Painting, Lettering, Entry Fees, Travel, Lodging, Food. John T. Jacobson, Appleton WI Saab46son@aol.com (920) 954-8864 fax 8847

Swap \$2 Spring Cleaning Special Issue #245 Only - Subscribers' Parts for sale - 25 words, **MUST be post-marked no later than March 25.**(you can file form 4868 for an automatic extension of your taxes, but you can't extend this offer.

First, I'd like to thank all those who sent holiday cards and greetings. It was unexpected, and most appreciated. I was also surprised by the number of people who ordered subscriptions of NINES for others as gifts. What a wonderful concept! Birthday gifts, Mothers Day gifts, Fathers Day gifts - what could be more appropriate for a Saab owning friend or relative than a subscription to NINES!

I'd also like to thank those who have shared their Saab experiences with me and the rest of the readers. Sharing experiences is an important part of NINES. Some of the articles I have dragged out of people after they posted a part of it on "Turbo!" the internet list. Based on the number of excellent stories I've received in that way compared to the number of "regulars" posting on Turbo!, I've concluded that there must be lots of other experiences NINES subscribers are having that are worth sharing. Don't worry if you don't think you write well. Norma and I "help" a lot of the stories we receive, and we enjoy doing it.

There have been some errors and omissions in the past few issues. I always mean to correct them in the next issue, but as the deadline approaches the past becomes ever more cloudy. In issue #241, in Bruce Turk's instruction on rebuilding the Saab 3 cylinder 2 stroke engines, I omitted the following:

New pistons, head gaskets, and rebuilt cranks can be purchased from J&B Imports, 2296A N. Batavia, Orange, CA 92865. Phone (714) 282-7378 and ask for Bud Clark. Pistons and head gaskets are also available from Mats Honson, Motor Sport Sweden, Nasnaregatan 1, S-641 48 Katrineholm, Sweden; telephone/fax 011-46-15012904.

As Bruce wrote me, "The article doesn't do much good if you don't know where to get the parts."

Good friend Lester Ewing wrote that in their third placed (equipped class) entry in the 1999 Owners convention (NINES #242) Duane Dostie rode along and assisted Kevin Quigley and Lester with the navigator's duties. Perhaps all that excess intellectual capability had something to do with their team's score busting 300 points in stage 2.

Rounding out a string of errors in three consecutive issues, in Issue #243 I referred to Columnist Chip Lamb's establishment as "East of Sweden". Chip's Virginia based business is east of Sweden only if one travels the long way around. The correct name of the facility is "West of Sweden SAAB", as shown in his ad.

My experiences with Saab Dealers contrast with the experience Tim Winker noted in this month's Rear View column. While I have been hustled out of some dealerships, the majority have welcomed me, given me a "cook's tour" of their facility, and shared their views of where Saab and their dealership are going in the market. Sometimes I know when I walk in that I'm not going to stay long. If it's a Saturday afternoon and there are customers hanging from the ceiling, there's a good chance that I won't be spending much time. Even then, however, after being told "I'm sorry I won't be able to talk long," I've spent hours!

Saab implemented their strategy of having fewer dealers who are either exclusively Saab or paired with just a single franchise in part to create dealerships who are more dependent on Saab, believing that they will subsequently become more committed to Saab. I believe that committed dealers are also the ones more likely to support local clubs as well. Here in Ohio we have three clubs in existence or in the making: "Tri-States" in the Cincinnati/Dayton area, Central Ohio in Columbus, and Northeastern Ohio. Tri-States counts David Horstmeyer, owner of the exclusively Saab franchise "Just Saab" in Cincinnati and Dayton as a sponsor. In Northeastern Ohio, Jerry Levine of exclusively Saab franchise "Ed Wolfe Shaker Saab" is a supporter of the local club. Midwest Auto Group, the dealer in Columbus, Ohio, sells almost a dozen other makes from their suburban dealership, including BMW, VW, Porsche, Audi, Ferrari, Bentley and Rolls Royce, Aston Martin, Lotus, and Land Rover. I'm in no position to say how well Midwest Auto Group satisfies their customers, but it is obvious from the sign on the door that Saab is not the "cornerstone" of their business. It is also true that they do not support the Central Ohio Saab Club. As Saabs are increasingly sold out

of exclusive franchises, rather than paired or grouped with whomever is willing to take them on, I think that the dealerships' support of local clubs will increase.

There is a letter from Dana Morong, whose automotive needs are best met by a Saab - a 95 of apparently 1960's vintage, and there is a letter from Ted Carwile whose needs are best met by a new Saab 95 Aero. Saab doesn't make the older models any longer, but as shown by legendary Saab Technical Trainer John Moss accompanying Gary Stottler in his 2-stroke odyssey (NINES #241), support for them is still strong throughout the company.

The press days at the North American International (Detroit) Auto Show provided a good chance to chat with Saab Cars USA executives. They weren't overwhelmingly busy except right around the time of the Saab Press Event, because most reporters trudge from press conference to press conference, crowding and nudging to cover what everyone else is covering. Everywhere else on the floor there are just the occasional stragglers or the truly enlightened who know that the best time to get photos, videos, and interviews is when the crowd is elsewhere.

I was again impressed by Dan Chasins' enthusiastic personal affection for Saab. After greeting me warmly, he immediately talked - not about Saab's sales numbers, not about the impending Aero Wagon introduction, and not about the GM announcement to exercise its option for sole ownership of Saab, but about his own purchase of a used 9000 Aero referred to in his letter to NINES. As for the formula for success in the US market, there was a healthy recognition by all at the Saab stand that success will derive from having excellent product, excellent product execution, and a supportive dealer network. Dan's letter gives an insight into Saab's employees' dedication to excellent product. The strong showing achieved by the 95 in such diverse quality forums as J.D. Power's surveys and Consumer Union's ratings indicates that product execution has reached "world standards." This brings us back to the dealer network. The jury is still out on that score, but I believe great progress is being made there as well.

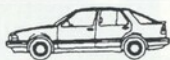

SAAB

SERVICE & REPAIR

JERRY SWEET
973-252-5151

Sweet Motors
379 U.S. Highway 46
Mine Hill, NJ 07803

Saab Parts @

Great Prices

Click Here!

Townsend Imports

Thomas Townsend & Ywan Mason
Hosts of The Saab Network Technical Chat

<http://www.townsendimports.com>

SAAB Technician-Mobile Service

Los Angeles CA

Walter Wong
Factory Trained



(310) 666-2406
(310) 815-8623 Fax

Swedish Dynamics, Inc.
SAAB PERFORMANCE PARTS
ENGINE SUSPENSION BRAKING
www.saabperformanceparts.com



Phone: 203-791-8826 Fax: 203-743-0015

West of Sweden SAAB
Charles City, VA

Specializing in vintage and newer
SAABs, 1950 to the present.
Deep Discounts on New Parts!
Rare items for the 2-digit models!

Phone: 804-829-9040
E-mail: chip@wmsbrg.com
Web: <http://www.wmsbrg.com/sweden/>

SAAB OWNERS BEWARE

Traffic police assume Saab owners have above-average incomes, which is why they target you for traffic tickets. They think you're more likely to pay up than to contest their revenue-generating practices in the courtroom. However, they overlook the fact that Saab owners are more educated and more motivated to stand up for their rights.

Let us help you fight that ticket!

call the

NATIONAL MOTORISTS ASSOCIATION

for Membership Information Now!
1-800 SPEED TRAP
or visit our Web Site at www.motorists.com



National Motorists Association

402 West 2nd Street, Waunakee, WI 53597
Phone: 1-608-849-6000, Fax: 1-608-849-8697
E-mail: nma@motorists.com

We're the organization responsible for the repeal of the 55 mph National Maximum Speed Limit. We could do much more with your support. Consider joining the one motorists' rights organization that truly represents your interests in issues such as emissions inspections, auto insurance, photo RADAR, red light cameras and speed traps. Most importantly, members have access to ticket-fighting assistance, attorney referrals and more information on fighting tickets than is available anywhere.

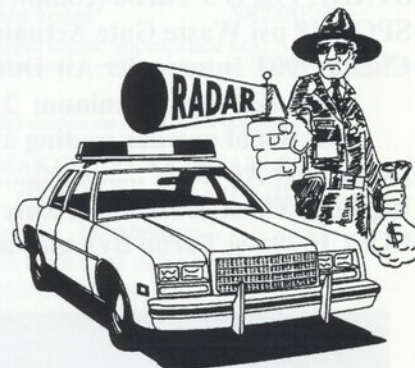

Exclusively
SAAB
Since 1969

Rust Free Used Parts

There is **NO RUST** in Colorado
125 SAAB'S TO PICK FROM

1-800-757-7222

519 Lipan St - Denver, Colorado 80204-4906
Phone (303)595-4646 - FAX (303)595-0124
www.milehibodyshop.com

Paragon Performance

The Leader in High Performance
Automotive Hose, Fittings and Adapters

**We Specialize in Saab Stainless
Steel Braided Brake Line Kits!**

Prices Start at \$77.00 for a 4 line kit
We also offer Stainless Steel Braided Hose, Aluminum
Fittings and Adapters for Fuel, Oil & Transmission Lines

Come visit us at:
<http://www.paragonperformance.com>

1-800-270-0333



New and Used SAAB parts

VISA/MASTERCARD ACCEPTED
TOLL FREE ORDER LINE

1-800-882-7220

Info: 612-389-3805 Fax#: 612-389-3875
35558 Brickton Road, Princeton, MN 55371

www.andrewsofprinceton.com
E-mail Chuck@andrewsofprinceotn.com

No longer just a rumor!

Limited-slip Differential

fits 99 and 900, 1975-93

S&J Automotive
1491 Howell Mill Rd
Atlanta GA 30318

404-351-SAAB
jack@mindspring.com



6450B VIA AVENUE, ATASCADERO CA 94322

- IT'S HERE!*** Stainless Steel - Flanged! - Cat-back exhaust - '83-'93 ('94CV)900 Intro Special 495.00
 RED LINE MTL 75W/80W or AMSOIL 75W90 (3qts. shipping & handling included) \$29.50
 INTRAX Lowering Springs Space Age Design! Lowers ride height by 1 1/2 inches (38 mm) \$295.00
Our shipments of Classic 900 INTRAX Springs was delayed, but they are here now!
 Air Inlet Kits (Please call for additional applications) 1999 9³ '85 to '98 900 & '86 to '89 9000 \$69.00
 APCs (exchange) Most Aggressive Modified Turbo Controls Available! Stage 1 32+ H.P \$295.00
 Stage 2 40+ H.P \$350.00
 Fuel Pressure Regulator 2.8 bar or 3.0 bar(your choice) \$65.00
 SPG 9 Rising Rate Fuel Pressure Regulator Power + Milage Awesome Unit! \$249.00
 STAGE 1 SPG 9 Turbo (complete unit exchange) all applications - 99, 900, 9³, 9⁵, & 9000 \$749.00
 SPG 9 18 psi Waste Gate Actuator Air Research Turbo's 900T & 9000T \$95.00
 Classic 900T Intercooler Air Ducts - Pair - (Huge increase '85 to '88 , good increase '89 to '93
 with our new Aluminum 2 1/4 inch lower duct) Aluminum \$195.00
 Optional powder coating available, any color and black or red wrinkle finishes add \$39.00
 Intercooler Air Dam (updated and now in black wrinkle finish) '85 to '93 900T \$49.00
 Big Bore Throttle Bodies (Please call for additional applications) '85 to '93 900 & '86 to '91 9000 \$225.00
 BOSCH 20 psi Turbo Bypass Valve 1981 and up ALL Turbo Saabs \$49.00

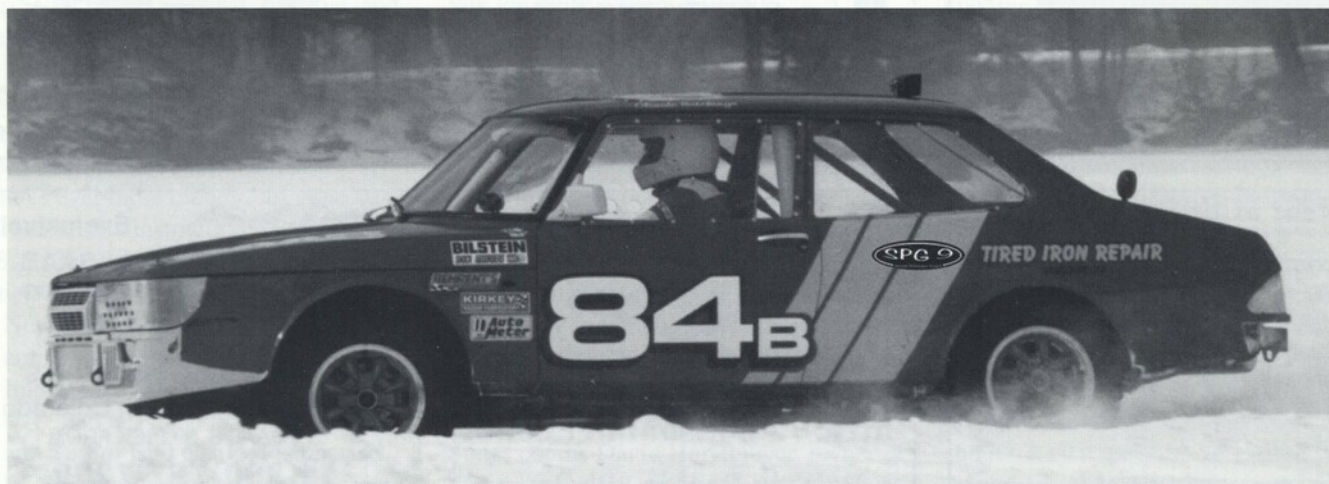

- SPG 9 Modified Vacuum Advance/Retard Unit - less turbo lag and better throttle response - \$95.00
 NOLOGY Hot Wires Ignition System including BERU 99.9% Silver spark plugs
 and SPG 9 Coil (NOW - Coil avialable in Black or Red Powder Coat or Chrome) \$195.00
 KONI Shocks The Very Best and Worth It! '68 to '80 99 and '78 to '93 (to '94 Convertible) 900 \$449.00
 '86 to '98 9000 (includes our modified struts! - exchange) \$595.00
 Chassis Braces (new product) 9000 5 Door '86-'89 Front & Rear \$295.00
 Sway Bars Now 900 and 9000 applications available now - 9³ coming soon \$249.00
 Stainless Steel Brake Lines (Shrink tube blue) also available in Red, Black, & Clear \$125.00
 Cross Drilled or Slotted Rotors in Cad Gold, Silver, or Black, with Hi. Perf. Pads - full set of 4 \$495.00
 CENTER FORCE Clutches..(light pedal effort & the most clamping force avail!) '83 to '89 .. 900 \$295.00
 '90 to '93 900 (to '94 convertible) and '86 to '89 9000 \$395.00
 External Voltage Regulator Kit Fits BOSCH Alternators \$75.00
 Two Speed Cooling Fan Switch with wiring adapter \$39.00
 Reprogrammed DI-APC's ECU's Motronics and Trionics Available Soon!!!

**CONTACT US @ (800) 847-4996 (SALES) PLEASE MENTION NINES!
 VISIT spg9.com TECH. SUPPORT (805) 461-1090 pst E-Mail spg9@fix.net**

MEMBERSHIP/SUBSCRIPTION

Address Change Only (please attach old address label)

NAME _____

ADDRESS _____

CITY/STATE/ZIP _____

HOME PHONE _____ WORK PHONE _____

E-mail address _____ Fax # _____

SAABS CURRENTLY OWNED:

Example: Year 1995 Model & trim 900 SE Body style 5 door
 Engine 2.5 liter V6 Transmission 4-spd auto VIN# _____ (for vintage Saabs)

#1: Year _____ Model & trim _____ Body style _____

Engine _____ Transmission _____ VIN# _____

#2: Year _____ Model & trim _____ Body _____

Engine _____ Transmission _____ VIN# _____

Please include additional cars on a separate sheet of paper. VIN for VINTAGE cars only (92,93, 95, 96, or Sonett). Visit our website: <http://www.saabclub.com> for information on owner surveys.

Brief comments here; use another sheet for longer comments.

Membership fees for the SAAB Club of North America/NINES are as follows:

UNITED STATES

- One year (6 issues) \$30.00US
 Two years (12 issues) \$58.00US

TO CANADA or overseas surface mail

- One year \$34.00US
 Two years \$66.00US

TO EUROPE AIR MAIL

- One year \$38.00US
 Two years \$74.00US

TO PACIFIC RIM AIR MAIL

- One year \$42.00US
 Two years \$82.00US

Please check appropriate box

(Canadian and International — Money order or check payable on a U.S. bank only.)

New members also receive two SAAB Club decals.

MAKE CHECKS PAYABLE TO "THE SAAB CLUB"

Mail to: Membership
 The Saab Club of North America
 2389 Chestnut Hill St. NW
 North Canton, OH 44720-5822

Phone: 330-497-0346 9 to 9 Eastern
 fax: 413-740-5583 email:nines@neo.rr.com

SAAB SWAP CLASSIFIED AD RATES:

Ads offering parts or Saabs for sale, or wanted, are available to members and non-members. Ad rates are for 25 words - more less - EXCLUDING your name, telephone number, address, etc. Extra words are charged at \$1.00 per 5 extra words. Classified ads MUST be prepaid. Ad rates are as follows:

TYPE OF AD	MEMBERS	NON-MEMBERS
CAR FOR SALE	\$10.00	\$15.00
PARTS FOR SALE	\$5.00	\$7.50
WANTED ADS	\$2.00	\$3.00
COMMERCIAL AD	\$10.00	\$15.00

DEADLINE: 25th of every odd numbered month for inclusion in the next issue.

Mail ads with full payment to: Saab Swap
 2389 Chestnut Hill St. NW
 North Canton, OH 44720-5822

NINES can also place your ad on The Saab Network (internet classified ad) for you. Include the TSN ad rate along with your NINES Classified fee: \$25.00 for cars, \$15.00 for parts, \$10 for wanted, for up to 150 words. We can also scan and submit your photograph at no extra cost. Please enclose SASE for return of photographs, if wanted.

Ordering Back Issues Up Through #239 (April, 1999)

Collection of all available back issues through #239. Currently over 30 issues in the package.

Non member price: \$120.00 Member price: \$90.00

Any 10 available issues Your choice of 10 issues.

Non member price: \$65.00 Member price: \$50.00

Individual back issues

Non member price: \$8.00 each Member Price: \$6.00 each

Saab Club members include your membership number (upper left of mailing label on NINES) with your order for member pricing. Prices include mailing to U.S. addresses. Send check or Money Order for full amount to:

SC Extras - Back Issues
 7675 Bear Trap Junction
 Saginaw, Minnesota 55779

See the web site, <http://www.saabclub.com> for an index of contents and issues available.

Ordering Back Issue from #240 On

Individual back issues will be in short supply and are available for the price of \$8.00 each for non-members, or \$6.00 each for members, postage paid to U. S. and Canada addresses. Please add \$1.00 for Europe, \$2.00 for Far East. Laser reprints are available for individual articles or whole issues at the rate of \$.20 per page plus \$.50 postage and handling for USA and Canada. Overseas, add US\$1.00. An entire issue reprint, cover to cover, is \$9.30. For a page count of a particular article, please e-mail nines@neo.rr.com. See our website at <http://www.saabclub.com> for tables of contents and available issues. Send check or Money Order for the full amount to:

Nines Magazine
 2389 Chestnut Hill St. NW
 North Canton, OH 44720-5822

Nines
The SAAB Club Magazine



2389 Chestnut Hill St. NW
North Canton, OH 44720

ADDRESS SERVICE REQUESTED

