

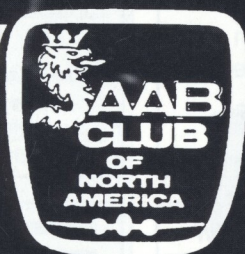

# Nines



The SAAB Club Magazine

#242  
November 1999



# www.SaabSuperStore.com

Andrews Inc. of Princeton



PHONE: (203) 284-8989  
FAX: (203) 269-8842  
www.luxurycars.com

**IMPORTS UNLIMITED**  
569 N. COLONY RD.  
WALLINGFORD, CT 06492

MICHAEL CARO      IMPORTED AND DOMESTIC  
President            AUTOMOBILES



The Oldest SAAB Dealer in Iowa  
3rd Generation -  
Family Owned & Operated

**MARTY J. ADAMS**  
Meyer Garage, Inc.  
SAAB Imports  
2687 480th Street • McIntire, IA 50455  
(515) 737-2239      Fax (515) 737-2601

**SAAB** 

**PLANET SAAAB**  
COMPLETE SAAB SERVICE  
CERTIFIED MASTER TECHNICIAN  
FACTORY TRAINED

JAY SITTON      45 Dore Street  
(415) 552-7222      San Francisco, CA 94103  
(SAAB)      Between 9th & 10th, Off Howard

**ADVERTISERS**  
This "business card" ad can be yours for as little as \$20.00 per issue. We will scan and scale your business card, or other graphic, to fit our ad format. Contact the Editor/Publisher for details.

**EUROPEAN**  
EXCHANGE, INC  
Specializing in Transmissions for Fine Imported Automobiles

MERCEDES BENZ • BMW  
SAAB • JAGUAR  
PORSCHE • AUDI  
PEUGEOT • VOLVO, ETC.

Rich Varjan  
201-489-7770  
155 Lodi St., Hackensack, NJ 07601

Mark Strohm      Jeff Hofslund  
**FOREIGN AFFAIRS**



of Duluth, Inc.  
722 E. Ninth St. • Duluth, MN • (218) 722-2246

Tim Brown      Kevin Booth

INDEPENDENT SAAB SPECIALISTS



We want you and your car to be happy

Full Service Auto Repairs

http://www.saablitzauto.com      (717) 626-5264

Strandberg's Auto  
Volvo Specialist  
Parts For European Cars - Rebuilders

John & Kevin Strandberg

P.O. Box 430 • 615 Polk • Centuria, WI 54824  
800-448-5121 (Nationwide) • 715-646-2388

1-800-444-0292  
512-329-8200  
Fax 512-306-0276  
www.speedometer.com

**Overseas Speedometer**

Rick Borth, Owner

Cable-Driven & Electronic Units • MB Quartz Clocks

- Audi • BMW • Porsche • Mercedes • Saab
- Volkswagen • Volvo • BMW Motorcycles

Please U.P.S. to: 100 Wallis Drive, Austin, Texas 78746

All Recycled Saab Parts  
93B, 95, 96, 99, 900, 9000



East West Auto Parts, Inc  
4605 Dawson Road  
Tulsa, OK 74115-4102

800-447-2886  
or (918) 832-7077  
FAX (918) 832-7900  
website: www.eastwestautoparts.com

THE MIDWEST'S LARGEST SELECTION  
OF PREVIOUSLY-ENJOYED SAABS.  
OVER 20 IN STOCK.



**TOM DONNEY MOTORS**  
FORT DODGE, IOWA  
800-626-SAAB  
IOWA'S INDEPENDENT SAAB  
SALES      SERVICE      PARTS

**Talbot** 

Sport Mirrors

**CIBIE**

Lighting Systems      E-code Lights

aardvark international  
http://www.cibie.net  
562 699-8887 tel. 699-2288 fax  
P.O. 509, Whittier, CA 90608





**NINES #242**, issued November, 1999,  
a publication of the  
**SAAB Club of North America**  
2389 Chestnut Hill St. NW  
North Canton, OH 44720-5822  
Phone: 330-497-0346  
9am - 9pm Mon - Fri Eastern Time  
Fax: 413-740-5583  
email: nines@neo.rr.com  
WEB SITE: <http://www.saabclub.com>

**NINES Editor & Publisher:**  
*Stephen Goldberger*  
**Conventioneer / Membership:**  
*Norma Goldberger*  
**Editor Emeritus:**  
*Tim Winker*

**Contributing editors & photographers:**  
*Chuck Andrews, Jack Ashcraft, Seth Benglesdorf, Rick Corwine, Phil Lacefield Jr., Bob Sinclair, Bruce Turk*

**Mailing Specialist:** *Jessica Goldberger*

**NINES** is published bimonthly by SAAB Club of North America. The SAAB Club is not affiliated with Saab Cars USA, Inc. or Saab Automobile AB.

**All material copyright 1999, SAAB Club of North America.** Material may not be reproduced without permission. If permission is given, credit must include the author's name and "NINES, the SAAB Club Magazine". The opinions and views expressed in articles are not necessarily those of the SAAB Club and its magazine, NINES.

**Editorial contributions** are welcome. All material submitted is assumed to be for publication unless clearly labeled otherwise. Machine readable formats are preferred. We cannot answer every inquiry and reserve the right to edit materials submitted. Those wishing to submit material on 3" IBM-formatted disks, please provide ASCII text files (<filename>.TXT), and include a printed hard copy. E-mail submissions should be in the form of an ASCII text file attachment.

**Photos:** Preferred format for photos is black-and-white, in 5"x7" or 8"x10". Good contrast color photos can be accommodated, no smaller than 3"x5", please. Photos used on the cover will be rewarded with a one year subscription to NINES and must be submitted in 8"x10" or with the original negative or transparency. For return of photos, include SASE of correct size and postage.

**CHANGE OF ADDRESS:** Eight weeks notice is required for change of address. PLEASE mail new address and old address, including zip codes, to the SAAB Club at the address above. e-mail OK.

**RETURNED CHECKS:** There will be a fee of \$20.00 charged for any returned checks.

**SUBSCRIPTION RENEWAL RATE** is \$30.00 per year in the US. Please see the form on page 43 for complete information.

**APPLICATION** to Mail at Periodicals Postage Rates is Pending at Canton, Ohio.

**POSTMASTER:** Send address changes to NINES, 2389 Chestnut Hill St. NW, North Canton, OH 44720-5822.

## Features

Saab International Meeting <i>by Doug Morse</i> .....	11
Nines Run the Rockies Tour 1999 <i>by Phil Lacefield Jr.</i> .....	14
High Altitude Driving Lesson .....	15
1999 Master Tech Challenge <i>by Stephen Goldberger</i> .....	17
Convention Contests: Autocross, Concours, Photography Contest, and Rally .....	18
Interview with Dan Chasins, President of Saab Cars .....	27

## Saab Clubs

Clubs, Contacts, and Calendar of Events .....	38
---	----

## Departments

Letters to NINES .....	4
NINES' Survey: Why did you purchase your first Saab? .....	5
Ramblings and Demands <i>by Phil Lacefield Jr.</i> <i>Plug in, Log on, Drive Out</i> .....	7
Professional Perspective <i>by Chuck Andrews</i> <i>Our Daddy's Alleged Defeat</i> .....	8
Saab News: Model Year 2000 Details and Prices, August and September Sales .....	24
Service Bulletins: 1992-1998 Clutch Slave Cylinder .....	30
SHOPTECH <i>by Jack Ashcraft: Repair of Saab 95/96 Wiper Blade Pivots</i> .....	31
Tech Talk: NINES' Readers offer service and maintenance advice .....	34
Dr. Nio's Saab Klinik: Sonett electrical and fuel delivery problems .....	36
Rear View <i>by Tim Winker</i> Performance Sells! .....	37
Saab Swap .....	40
Looking Out (from under NINES) <i>by Stephen Goldberger</i> .....	42

## Front Cover: Serious about Saab Service!

Mark Kline of Scandia Tek uses a "break-out-box" and a computer-based digital oscilloscope to diagnose a Saab 900's electrical system.

**SUBSCRIBERS:** We have received over 100 address change notices from the Postal Service as a result of last issue. This delays your magazine, exposes it to more handling and possible damage, and costs NINES a fee. PLEASE keep us up to date with your address.

When renewing your subscription, and we are certainly appreciative when you do renew, please **do not staple** your check. We promise we won't lose it.



**Coming Next Issue:** How much of what you see above will fit in the back of a 9<sup>5</sup> Wagon? How much of that will or will not fit in a 9000 Hatchback? And how can one 17 year old girl survive college with just that? Send your own stories about what you have packed and carried in YOUR Saab.



# Letters to NINES

Enclosed is a photo of our Saab Family:

- 85' Saab 900 210,000 miles
- 87' Saab 900S 120,000 miles
- 95' Saab 900S 30,000 miles

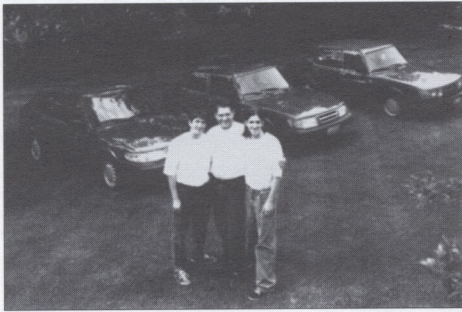

In 1985 we bought the 85' Saab 900 as our family car. It has served both our sons through their high school years and will go with our youngest son to the University of Iowa come fall.

Last year, on a rainy morning, my husband rolled his 1990 Saab 900 on a gravel road ending upside down. The car was totaled but he walked away without a scratch or bruise. Because my husband has always done most of the repairs and maintenance on our Saabs, he took all the parts he could salvage from the totaled 90' and has used them on the 85' and the 87' 900S that our oldest son purchased last year. He even put his engine, that he maintained with care, into the 87'. The 87' should last a long time for our oldest son who is finishing his schooling at the University of Iowa. Our son reports that he now gets "the wave" when he drives on campus. We purchased the 95' Saab 900S new and hope to have it for a long time. All of our Saabs are red so our friends and relatives jokingly ask "What's with all the Red Saabs?"

*Mrs. Susan Nohr  
Bettendorf, IA*

Dear NINES,

Having read Tim Winker's account of ferrying the new 9—3 up to Deadhorse, Alaska (NINES #238) for the "Alaska to Florida Challenge", inspired me to make a similar roundtrip trek north. Traveling in a brand new car with fellow drivers eases the psyche a bit. I thought I would attempt to do it solo in my 85 900T. Sort of a

challenge in itself.

My journey included a brief trip back to the east coast before deciding to go for it. With really no special preparations, I left Omaha, NE and pretty much mirrored Tim's route to the Great White North via the ALCAN Highway. The only problem I encountered was a flat tire north of Coldfoot, AK. It was early May and the Dalton Highway was still fresh coming off winter's ravages, so the road was a little on the primitive and dusty side. I succeeded in following the Pipeline from Prudhoe Bay to Valdez, AK. As a side trip, I traveled as far west in Alaska as I could drive, to Homer. On my way back, I detoured off the ALCAN Highway and bumped my way south through British Columbia on the Stewart/ Cassair Highway. Then I leisurely drove down through the Jasper and Banff National Parks in Alberta.



## Gary Clower and his Saab at the Arctic Circle

When I finally drove back into my driveway in New Mexico, the total 3 week trip encompassed 10,000 miles. The 900T was averaging 33+mpg at 65mph. The 85 Saab now has 406,120 miles on the odometer and the engine, turbo, and transmission are all original. The only major repairs to the engine and transmission have been a new clutch plate and a new timing chain. I hope the "new" Saabs can match the "old" Saabs in durability. Now that's a challenge!

*Gary Clower  
Alamogordo, NM*

Saab Club of North America:

Saab did not officially import the 900 SE Sensonic to the US but some where brought over for promotional events. Did any stay, do you know? Do any of your members own a Sensonic? Did Saab import the Sensonic to Canada?"

I've been in contact with Saab USA in the past. They seem to want to disown the Sensonic. Do you know how it fared in Europe and other parts of the world, if it is still manufactured, or if there are any plans for its future?

*Elizabeth Robinson  
Alendale, CA*

*Sensonic is Saab's electronically actuated clutch. The clutch in this system operates automatically under computer control, providing much of the convenience of an automatic transmission while maintaining all the performance, fuel economy, and control of a manual transmission. In addition, the more accurate clutch operation made possible with the automatic controls promised to give longer clutch and transmission life.*

*We contacted Saab Cars USA and asked them your questions. Precisely one "pre-production" sensonic equipped 900 was brought into the USA for evaluation. SaabUSA declined to import them because they believed that demand would not be sufficient to justify the costs of training technicians to support the product. When the system was introduced into Europe, it was met with little demand and subsequently discontinued. Despite the high fuel prices and their tradition of manual shift transmissions, those who choose not to use a clutch prefer a fully automatic transmission. While there are no immediate plans to revive Sensonic at Saab, automatic clutches are used in Formula 1 racing cars in conjunction with electronic "paddle shift" transmissions. This keeps the door open for possible future applications throughout the industry. -Ed.*

**CATALOG NOW on  
WEB SITE**

[www.saabservices.com](http://www.saabservices.com)

**Intellect Corp.**

**1-800-326-0599**



## NINES' November Survey

*The NINES Survey is a new feature, in which readers respond to a question we ask. Our November Survey Question is "Why did you purchase your first Saab?" We got the idea for this feature, and for our first Survey Question, at the 1999 Saab Owners' Convention. We posted the question on The Saab Network and received the following among the responses. We'd like to thank all the people who responded, and we hope that many of you respond to our next Survey Question. Our Survey Questions for January are posed at the end of the feature.*

**Please feel free to respond to this issue's question as well.**

A few years ago a friend asked me to look at his 85? Saab 900. It had 175000 miles on it. The problem (which I couldn't fix) was in the 5 speed transmission. But I did know a good Saab mechanic where I towed the car for him. He repaired it, and when I picked up the car for him I had an opportunity to drive it for a few days. I was amazed that the car was so tight and had no rattles or any other noises one would expect in a car of that age and with that mileage. I never cared for the classic 900 styling so when the 94 900 came out I bought a 900S automatic for my wife. The car was built in February so most of the teething problems had been worked out. The car now has 70000 miles on it with no problems, and no rattles either.

*Richard Blumenthal*

In college, I was on the ski team. At the time, I drove a Ford (Mercury) Capri, rear wheel drive with a V-6. That car could (and did!) get stuck in a flat parking lot with 3" of snow. Many of my teammates drove Saab 99's and didn't get stuck. I replaced the Capri with an Alfa Romeo coupe which was much better in the snow, but the defroster was terrible, the body began to quickly rust, and I still got stuck. My friends with their Saab 99's had clear windshields, warm seats, no rust, and didn't get stuck. I SAW THE LIGHT and bought one of the first Saab 900's, a 1979 900 EMS in a lovely light blue metallic. Being an engineering major, the 900 was, to me, an act of grace. Every-

thing made sense on the car. The design was intelligent, logical, and well executed. (Remember, I came from an Italian car....) While by today's standards rather slow, at that time the EMS was a fairly fast car. The only thing that bothered me was getting passed by the new-fangled Turbos.

Anyway, I was hooked. My Saab went skiing with ease. The back end swallowed everything my crazed college mind could consider fitting in it. Reliability was great (remember, I had an Italian car) and when I slid off a mountain road in 1981, it crashed like it was supposed to and protected the passengers. I was such a convert that my parents replaced their BMW 530i with a 900 Turbo in 1982 and today drive a 9<sup>5</sup>SE V6.

Since that original EMS, I've owned a 95, a 900 SPG, a 9000, and now drive a 9<sup>3</sup>. My whole family drives Saabs as do many of my friends. While the new cars, to me, don't have quite the individual panache of the 99 and the 900, they are still true to the original reasons I bought a Saab: practical, safe, fun-to-drive, good for trips, economical, and a good value.

*Tod Windsor  
Coshocton, OH*

Researched cars thoroughly - needed something a college family (one kid already) could afford. It became obvious (to me) that front wheel drive was the wave of the future. My choices were limited to the Auto Union, SAAB, and

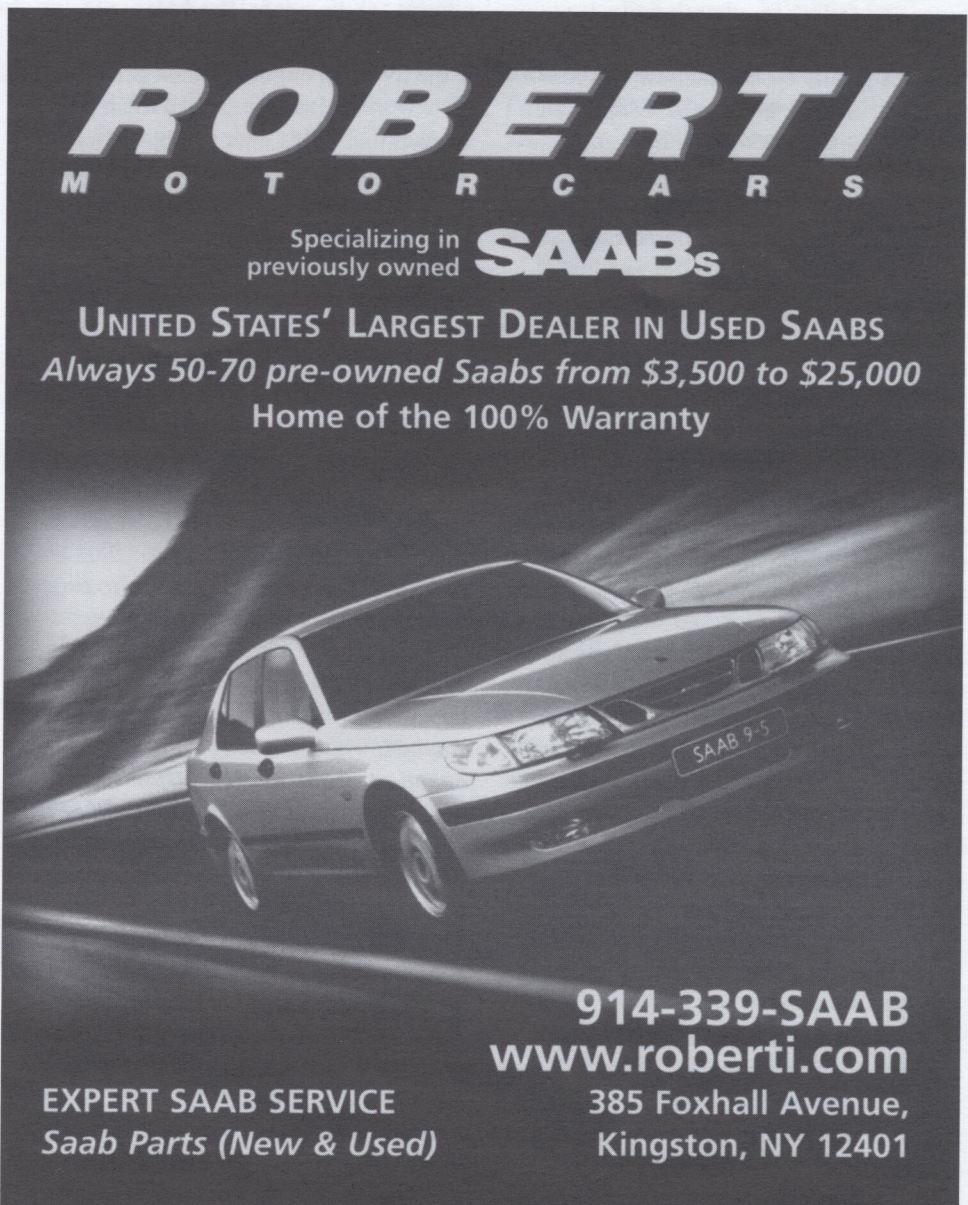

**ROBERTI**  
M O T O R C A R S

Specializing in previously owned **SAABs**

**UNITED STATES' LARGEST DEALER IN USED SAABS**  
Always 50-70 pre-owned Saabs from \$3,500 to \$25,000  
Home of the 100% Warranty

**914-339-SAAB**  
[www.roborti.com](http://www.roborti.com)

**EXPERT SAAB SERVICE**  
Saab Parts (New & Used)

385 Foxhall Avenue,  
Kingston, NY 12401



Citroen. Scratch Citroen, too expensive. Couldn't locate an Auto Union dealer. Found a SAAB dealer 50 miles away in Boston. Traded my 1951 Pontiac for a spanking new blue 1959 SAAB 93. Was concerned the whole trip back home about sitting so close to the windshield.

I was careful to put in my own oil in "True Blue" but on a trip to Michigan, handed the station attendant the can of oil and gave him instructions. He forgot and I failed to check. 15 miles later, seize city. Bought a brownish tan 1962 SAAB. Added a blue 1965 SAAB 95 later, and when Brownie expired, bought a nice red 1968 SAAB 96.

It got totaled one night by getting between a drunk driver and a monster elm. As this was in the midst of hard financial times and failing family relations, I walked and biked for a while. When finances finally eased and new relationships blossomed, got a used 1974 99 and then turned that over into a new green 1975 99.

Picked up my 1981 SAAB 900 3-door "Tomato Soup Special (I think they called it Terra Cotta)" as a burn-out at a junk yard in 1982. New glass, wiring, dash, etc. and I had a car that I loved and drove until 1998. During that time, we had a 1983 900S Sedan for my wife. That evolved into another silver 900, this time a 1985 3-door. Two years ago, we traded it in on our present (214k)1986 900T 3-door. Love that 3-door design. When Soupy succumbed to rust (that engine fire apparently cooked all the primer and paint up front. It looked ok, but when the rust got a foothold, it was a lost cause. So I replaced it with my "brand new" (as far as I was concerned) 1980 900 3-door. 165K, still has no rust. I use the car as my truck and it gets hard use. Too bad, really, as the previous owner(s) had done a superb job with maintenance and cosmetic preservation.

I like (classic and pre-classic) Saabs!

Bob W. Anderson

I was never a "motor head" in high school - my first car was a chevette. Later in life, I took a job where I met a lifelong friend. I was talking about wanting to buy a 240Z - I had never had a sports car. This guy was a Saab person, and showed

me a picture of a 1978 99 turbo - which he wrecked. It so happened that he knew of a decent '78 99 EMS - the body was pretty good. Somehow he convinced me to consider making a turbo out of it. I bought several 77 and 78 99's for the wheels, seats, and heater control knobs. The first one was a 77 EMS trunkback. It was one of the unfortunates to have been manufactured in Belgium. I guess they shipped unpainted bodies across the North Sea. This one looked like it had been dunked in acid. But I got it running and drove home (illegally). I think the smell of the car was what got to me. It turned out to have had a cracked injector line during the drive - so I'm lucky I got home.

My friend mentored me through the conversion of a nice (cardinal red) EMS to a turbo. Quite a job. But I learned a lot about how Saabs were made. It seemed as if the Swedish engineers took pride in their work. Little things like the little bracket that holds your cam gear in place when you take off the head. That was designed for the mechanic.

I still have the car, and 3 900s (85 and under). I like the fact that one ball joint fits all, and the door handle on a 1973 glc fits a 1988 SPG. Now I do all my own work and I've even rebuilt a 5 speed - rolled a pattern with grease to match the ring and pinion and it is so quiet.

One day I want an 86 t convertible.

Phil Oliver

For future issues, we would like to print answers to the following questions:

- 1) Many of us have done it. It seemed like the right thing to do at the time, or maybe it was something that escaped our attention. Either way, it certainly didn't turn out the way we wanted, but when we look back, it surely was funny! What "wild and crazy thing" did you do and live to tell about?
- 2) Saab is running radio ads on the local commercial classical station. "Why do you own a Saab?" a lady with a cultured British accent asks. The spot goes on to give a couple of very good reasons, then suggests that if you don't have a Saab already, you should go to the dealer and try one. So write to us and tell us: "Why do you own a Saab?"

## Hakkapeliitta

### NEW STUDLESS HAKKA Q

The Hakka Q's new Spiral Sipe System creates dense siping with tremendous grip. Better handling, longer wear from a studless snow tire.



### HAKKAPELIITTA 1

Excellent bite in snow & ice, combined with exceptionally stable handling on bare pavement & super wear. Studdable.



### HAKKAPELIITTA NRW

Aggressive all-season or high speed winter use.



We have steel wheels.

GREER ENTERPRISES, Inc.

Call Toll Free



800-325-2598



Milwaukee, WI

800-270-SAAB, Parts

724-238-0900, Parts

724-238-0099, Fax

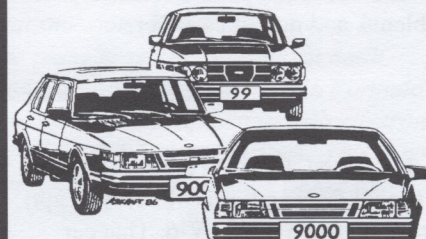

DENNIS SWEENEY

ROAD TESTED SAAB PARTS

334 Wilpen Road

Ligonier, PA 15658

Late model Road Tested  
900s and 9000s for sale.

Rebuilt transmissions, 900 and  
9000, manual and automatic

Used mechanical and electrical parts,  
interiors, accessories, sheet metal, rebuilt  
steering racks, wheels, heads.

Same day shipping on most items.



# Ramblings And Demands

by Phil Lacefield Jr.

## Plug in Log on Drive Out

Despite claims to the contrary, Albert Gore Jr, the man voted Most Likely To Beat That Bush Guy In November, did not invent the Internet. This massed collection of the world's computers, friend and eternal companion to some, bane of existence to many others, sprang from the perspiring minds of military and university computer geeks in the American Southwest eager to share information over long distances without having to wait for Mr. Postman to make his daily rounds. Although modem speeds in the mid-1970s were dismal at best – look ma! 300bps! – the groundwork was soon laid for what would one day become the driving force behind the gargantuan phenomenon known as electronic commerce, doing away with international barriers and connecting the citizens of the third rock to one another with instantaneous mail and video, providing health care answers that may save a life, helping travelers avoid delays, providing up to the minute news and stock reports. To use a grand generality, the Internet is quite possibly the finest tool man has invented since the can opener, and will help propel the human race past its infatuation with daytime courtroom shows and professional wrestling and out among the stars.

Ah, who am I kidding. As far as we're all concerned, the Internet exists for one purpose, and one purpose alone: Saab freaks and their freaky obsessions. Sick, ain't it?

But let's look at some numbers here: at last count, my favorite web search engine ([www.dogpile.com](http://www.dogpile.com)) listed an astonishing 543,619 sites containing or referencing the word "Saab." Everything from the official Saab Scania site ([www.saab.com](http://www.saab.com)) and its US variant ([www.saab-usa.com](http://www.saab-usa.com)), to every Tom, Dick and Larry with a few free megabytes of hard disk space on his web site and a scanner posting pics of his rusty old 99.

The finest in automotive expertise, outstanding good advice and help out of a Saturday afternoon do-it-yourself pinch is represented (our beloved [www.townsendimports.com](http://www.townsendimports.com)), as well as hi-po parts tuners who cater to a tiny niche of owners of a tiny Swedish marquee who just can't get enough boost ([www.spg9.com](http://www.spg9.com) and [www.evergreen-engineering.com](http://www.evergreen-engineering.com).)

Manufacturers obviously aren't the only ones with net authoring savvy, however, since a little more digging will uncover for you official Saab club sites aplenty, such as our own at [www.saabclub.com](http://www.saabclub.com) and the ever-popular Saab Network ([www.saabnet.com](http://www.saabnet.com)), and dealers in every state, country and region of the world - try out [www.orc.ru/~saab/](http://www.orc.ru/~saab/) for a unique Russian take on things troll-like. Looking for a used Saab? Surf to [www.traderonline.com](http://www.traderonline.com) or [www.classifieds.com](http://www.classifieds.com) for up-to-the-minute listings from sea to shining sea. Trying to build up that library of old Saab toys, ads and memorabilia? There's nothing quite like keeping an eye on [www.ebay.com](http://www.ebay.com), the largest online auction in the world that offers up some excellent gems for the discriminating collector. Books aplenty are to be had at [www.amazon.com](http://www.amazon.com), although most of the good ones are out of print and better found at [www.vintage-books.com](http://www.vintage-books.com) and [www.motorlit.com](http://www.motorlit.com). Parts are never a problem, just point and click to [www.vip-part.com](http://www.vip-part.com) or maybe [www.goldwingusedsaabparts.com](http://www.goldwingusedsaabparts.com) and shop like a caffeinated mallrat on a sunny Saturday.

Let's not forget the over-the-top Saab owners, though, without whom none of these electrons would be inconvenienced on a daily basis. Tops on the list are Joisey boy Larry West at [www.saabturbo.com](http://www.saabturbo.com), Chris Moberg and his outstanding Sonett registry at [www.vintagesaab.com/sonett](http://www.vintagesaab.com/sonett), Chip Lamb and his irreverent West of Sweden page, if you can forgive the Jaguar references ([www.wmsbrg.com/sweden](http://www.wmsbrg.com/sweden)), and Thor Carlson's noble attempt to keep them all tied together in one place at [home.ptd.net/~carlson/](http://home.ptd.net/~carlson/). The most fun you can have online without seriously upsetting the significant other is signing up to one of the Saab discussion groups, either in the raw free-flow form or a condensed digest that

is a bit easier to read. The most popular are the Turbo! list at [www.secret-secret.com/turbo/](http://www.secret-secret.com/turbo/), catering to all years and models of Saab, and the more vintage vSAAB list at [www.onelist.com](http://www.onelist.com). Be prepared to dig through a LOT of emails if you sign up for full versions however: try the digests first, until you get a feel for it.

Sure does seem like a lot of places to go and things to see, you might say to yourself, and you'd be right. With over half a million Web listings and more being added daily, it's unlikely you'd see them all in two lifetimes, so what's the point? Let's just say you almost certainly won't be disappointed. For example, I found my very first 96 on the Internet, a '68 V4 in nice shape from Brad Burns, as well as three whole cars' worth of spares from another online source. I first saw my current daily driver, a '95 9000 CS, on my local dealer's web site listing ([www.justsaab.com](http://www.justsaab.com)), and bought it the same day based on that quick look. Having recently returned from the 1999 Saab Owners Convention and Nines Run the Rockies tour held in August, highlights of which can be found at <http://www.netway.net/greenmountain/conv.html> (see article pp. 14 -ed.), I finally got to put faces to names and email addresses and now count myself very lucky indeed to be friends with the likes of Lester, Chip, Lewis, James, Uncle Bob and the Lovely Anne, Thor, Duane, Carl, Tom, Scott, Kevin, Christine, Paul, Chad and, yes, even Neil. Each and every one of us has a daily running conversation, delivered fresh and piping hot to our email boxes all day long, and all for free.

New friends, excellent parts sources, cool pictures and rally results to download and gloat over, all available 24/7 to anyone smart enough to turn on a PC. What more could you ask for?

Maybe this Internet thing will turn out to have some practical uses, after all.

*Don't let him fool you: Phil is so wired to his computers, he secretly wishes he could have a serial port mounted in the back of his head so he can communicate directly with his beloved Palm Pilot. Check out the insanity at [www.lacefield.com](http://www.lacefield.com).*



## OUR DADDY'S ALLEGED DEFEAT

Another successful Saab Owners Convention has come and gone. Thanks to Jerry Danner and the Rocky Mountain Saab Club and Saab USA for making it so successful. Thanks also to Rich Hruda and his co-workers for planning a fantastic Rockies Tour. I intend to write a little about the tour in the next issue of NINES.

When we originally planned our Colorado trip, we had decided to take in both the Rockies Tour and the convention. That meant we would forego the Sunday convention activities so we could get home a day earlier. When we actually got to the convention and saw what was planned for Sunday, I knew we had to stay and participate. A number of focus groups, manned by Saab Company people, were to present information on several different topics. They were as follows:

- A) Question & Answers with Master Techs
- B) Saab's New Global Ad Campaigns and Brand Strategy
- C) Saab's Quality Assurance Program
- D) Future Retailing Strategies
- E) Saab Club Gathering

The group that I was keenly interested in was D. When I got to the table where this group was to meet, I was greeted by the fine group that you see in the picture. The four men are Saab USA employees and Annette Adams, who along with her husband Marty, own Meyer Garage (Saab Dealer) in Meyer, IA. Annette was an attendee but all the rest pictured were there to help present or explain what Saab is doing, where it is going and why. They must have anticipated a large group since the presenters were five-strong. It turned out at the peak time that there were only four owner-enthusiasts in attendance. What a shame!!!

These guys were prepared. They shared Saab's marketing philosophy and discussed any detail we desired. They had someone with expertise in almost all areas of the company. They talked about five areas that Saab Cars USA, Inc. had focused on.

- 1) World class product program
- 2) World class quality
- 3) Customer interaction
- 4) Consistent and compelling marketing message
- 5) Retail strategy and structure



**Left to right: Annette Adams, Ryan Kelly (Manager of Customer & Field Systems), George Locascio (Director Western Region), Bill Buckley (Manager, Fixed Operations - Training) Michael Conti, National Training Manager, and Abe Buchbinder. photo by author.**

Out of these five categories, I would summarize the discussion as follows: The dealer group has decreased from about 350 to just 205 dealers. The return on investment for the dealers was about 8% just a couple of years ago and has increased to the 20's % with a goal of 30%. That has occurred as sales have increased per dealer and over all sales are at their highest levels since the 80's. I'm sure this issue of NINES will have a press release with the latest sales figures. We all know that a good strong dealer network is an absolute necessity to Saab's survival and prosperity. A review of the anticipated (by 2002) remodeling of many of the dealers to comply with the new design standards set by Saab was discussed. The goal is for every dealer in the country to look alike (cookie-cutter design). Signage, building exteriors and interiors will all be alike. Recognition, (like McDonalds restaurants), with the expectation and realization of the same quality service at every service point everywhere. The example was that when you see a McDonalds sign you have an expectation of what it will look like, what service you will get, and what is on the menu. No surprises! Lofty goals indeed. There are currently 15 major construction projects underway by

dealers to meet these standards. Some dealers are expected to spend several hundreds of thousands of dollars to meet the desired standard. It was nice to hear that Saab is helping in a number of ways to ease this financial strain. Dealer technician and sales training were also discussed noting the increased numbers of persons being trained by Saab. They are making great efforts to train more people and it is bearing fruit.

All this was good to hear, but our daddy (General Motors) has been up to some mean tricks. Seated next to me was Ryan Kelly, who surely could address the General's attack via the internet on its dealers in Texas. Since Ryan Kelly is the man in charge of internet activities at Saab I thought he could clear up this matter. It seems GM thought they could set up a website ([www.driverssite.com](http://www.driverssite.com)) and market used cars directly to consumers. GM had two stores

in Houston where cars could be delivered on site for test drives and then could ultimately be purchased. Neither store had an inventory but only a sales staff. In June, Roy Pikus of GM had gone to Houston (as reported by Bob Wallace of *Computer World* 7-14-99 issue) to explain the site and stores to its dealers. Rocky McCullough, General Manager of Goodson Honda-Pontiac in Houston attended the meeting. "They didn't ask for input and basically said, 'Here we come, get ready,'" McCullough said. As you can imagine, not only were local dealers upset by the move, but also nationally the National Auto Dealers Association (NADA) became quite vocal. Tom Keery, a GM dealer in Massachusetts and head of NADA's GM committee, which represents 7500 dealers, said, "Unfortunately the decision was made with out dealer input which usually results in not the best decision. I'd like to work with them on how to make it work." The thing that stopped GM dead in its tracks was a Texas law passed in June which prohibits a manufacturer from competing directly with its franchise holders (my interpretation). There are about 40 states that have similar laws. So the Texas Department of Transportation (DOT) denied a license to



[www.driverssite.com](http://www.driverssite.com) (General Motors Corporation) to sell cars in the state of Texas. Mr. Pikus of GM stated at this juncture, "We fully intend to get into this market and have expectations we can come to a realization and work this out." GM wouldn't say if this would lead to a nation-wide operation.

In the September 6th issue of Auto Auction Shopper, Kevin Doak reported that GM had an agreement with George DeMontrond, owner of the DeMontrond Automotive Group to buy at least one of the driverssite stores (General Motors already had these buildings) and operate in much the same way that GM had planned. There still seems a problem with GM and the DOT law because Texas DOT has not given the DeMontrond Group a license and the group withdrew its application. This group already has Buick, Olds, Chevy, Volvo, KIA, and Suzuki dealerships in Texas, so they aren't new to this game. Can you believe GM, after the dealers have spent hundreds of thousands of dollars to build dealerships to display and service GM cars that they would undercut them like that? Do you suppose GM could undersell the dealers when they have an extremely low overhead and no service facility?

As I brought this subject up it seemed

like everyone in the Saab USA group was quite familiar with the information but would like to have talked about FORD. Ford Motor Co pulled a deal in Utah which was similar in nature and was also stopped. After some discussion by several in the group, which I would term as avoiding the issue, Ryan Kelly stepped to the front. He stated that he was on two boards at General Motors and that GM and Saab had no intention of marketing cars in the Texas manner or any other in direct competition with its dealers. Hooray! You may not like all the dealers, but we need good dealers and they need to be healthy. If a manufacturer can sell directly and saddle the warranty, etc., on the dealerships along with the loss of sales volume, the dealer is going to be in trouble. For now, everybody is safe! Our friends, Marty & Annette aren't going to have to compete with GM. The decision isn't made yet if GM will buy the remainder of Saab but they have until the first of February 2000 to decide and write the check. I think when it happens we need to all be concerned about our Daddy, the General and his responsibility to his dealers and consumers.

Thanks again to the Marketing Focus Group (pictured) for a very good informative session. It's this kind of folks that will ensure Saab's ultimate success.

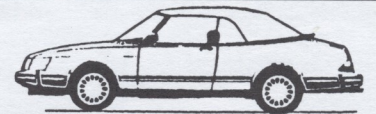

**SAAB CONVERTIBLE TOP PARTS**

Top Cylinder

\$120



Motor Pump

\$199



Hold down tension cables ...\$29.95/pr

**1987-94 Stayfast Canvas Tops**

with heated glass window.....\$499

**1987-94 Headliner, black.....\$149**

**1995 Stayfast Canvas Tops,**

with heated glass window.....\$1150

**1996-98 Stayfast Canvas Tops**

without glass.....\$1000

**1996-98 Original type Sonnenland**

**Car covers, universal fit**

Indoor/light weather.....\$47.95

Moderate weather.....\$73.95

Evolution 4, all season coverage....\$129.95

**HYDRO-E-LECTRIC**

Unit 8, 5475 Williamsburg Dr.

Punta Gable, FL 33982

**Call Toll-free 800-343-4261**

Tech Help: 941-639-0437

Fax: 941-639-0376

*America's Convertible Headquarters*

# Garry Small Saab

**Saab Exclusive for over 10 years!**

## 800-920-7222

Garry Small Saab has been ranked number one in customer service and sales satisfaction by J. D. Powers and Associates



**nokian  
TYRES**

We have Nokian Street and Snow tires, including the new Hakka 1 snow tire

Fast friendly expert service.

Non-inflated part prices.

**Extensive Saab Inventory**

**800-920-SAAB**

**Business hours: 8:00 AM to  
5:30 PM PST**

**All major credit cards accepted**

**[www.saabstory.com](http://www.saabstory.com)**

### Shop Manual for Saabs

Saab 900 8 valve 1981-88 Bentley

Saab 900 16 Valve 1985-93 Bentley

Saab 9000 1986-95 Haynes





If you are not using original SAAB parts,  
**YOU MUST BE USING  
SCAN-TECH SWEDEN PARTS**



Scan-Tech Sweden is the world's largest  
manufacturer and supplier of  
SAAB aftermarket parts.

**Ask for us by name!**

 **WIN**   
**a FREE Trip for Two to**  
**STOCKHOLM SWEDEN**  
winner drawn November 1999  
*Airline Tickets • Hotel for Four Days - Three Nights  
Tour Beautiful Downtown Stockholm • Dinner at the world famous Grand Hotel  
Visit Scan-Tech Sweden World Headquarters*

REGISTER AT:

**[www.ScanTechSweden.com](http://www.ScanTechSweden.com)**



**BRNO, Czech Republic  
June 18 - 20 1999**



For those of you who have not had the opportunity to travel in the Czech Republic, 1/2 of the former Czechoslovakia, you do not know what you have missed. This is a beautiful country for whom the likes of Skodas, Tatras and Aero's have been produced for the driving pleasure of the friendly natives. If you know anything about these cars, then you must understand the appeal that Saabs would have for these people.

The Czech Saab Klub was the host for this years international Saab meeting. The meeting was held near the second largest city in the Czech Republic, BRNO. BRNO is also known as the home of the Czech Grand Prix track, Masaryk, both old and new. The old track, prior to the second world war ran for 37km on roads around BRNO and hosted top international events. The new track is a modern facility of only 3.4km. As of yet only the top echelon of motorcycle races are held there



**The town of Brno, Czech Republic, site of the 1999 Saab International Meeting.**

and Formula One cars are only a memory. However, the names of Saab and Erik Carlsson are a part of the history of this site.

As for the event itself I have to say that in comparison to past events in other countries this one was not the best. You must understand two things. First I would never say anything bad about these events as I know first hand the efforts that go into making these events happen. Second, if you have never attended an international meeting outside of the '97 Trollhattan Jubilee, they are quite different from US national conventions. In the U.S., the meetings always have more to do than there is time to do it all. Rallies, autocross, track time, concours, tech sessions, and swap meets all keep you constantly busy. In Europe they all follow a fairly common format. Friday night has a short welcoming reception with some sort of refreshment. Saturday is usually held at some special site with all of the cars parked together. During the day there are people selling



**Saabs on display.**

things out of their cars and hanging out checking out all of the cars. Usually there is some sort of tour or organized drive and then the banquet on Saturday night. The banquet is attended with many showing up in native costumes bearing gifts from their country's Saab club for the hosts. Afterward usually involves dancing and libations. The concours is usually on Sunday with the winning cars displayed for all to see.

Friday night started with a small buffet dinner per the normal format. Erik got up for a very short speech. The crux of what he said was that he had

just turned 70 (as we all knew) and he was tired of people addressing him as "Mr. Carlsson" now that he turned 70. He wants to be called ERIK. The rest of the evening was spent finding old friends from the past events and making a few new ones along the way. There were some interesting stories from the Europeans about entering the Czech Republic. Most of Europe, under the EU control, is effectively without borders, but you still need a passport to get into the Czech Republic. More than one group had to return home to retrieve the missing documents. Also there is a "road tax" to be paid for driving there. If you did not understand the signs crossing the border and failed to get a sticker, chances were good that you would be stopped somewhere by the police.

As the evening grew late we headed towards the hotel where the majority were staying. It was only supposed to be 10 Km away and we had what we thought were clear and easy directions. The only problem is that there are no street signs at any of the intersections and the maps were not exactly to scale. This coupled with the fact that most of the people you could ask for directions, did not speak English. We were not alone in our hotel quest as we followed many a SAAB around the same circles that we had been driving. Since we were incognito in an OPEL

(courtesy of HERTZ) no one felt compelled to follow us! (a good thing for them) By sheer luck we stumbled across the place, several kilometers from where we THOUGHT it should be based on the maps. So here is the lesson, common to much of Europe but much worse here, street names mean nothing on maps. You follow road signs to the postal district name (written in Czech) that you are going to (like in English would be CENTRUM, OLD TOWN etc) so you need local maps BEFORE you get there. At your first encounter with a Czech Tourist office, buy the town maps of where you intend to visit. The Michelin guides and the like are ok for highways and the like, but once you get to a town, use a local map. The good news is that my navigator is still speaking to me....



## Saab International Meeting

After this ordeal, that took about 1½ hours, we were ready for a drink at the bar. This is where we found out that we were not alone and many Saab folks had beaten us there. Now, one of the big dilemmas in the Czech Republic (from here on called CR) is that they make excellent beer (home of PILSNER type beer) and it is extraordinarily cheap. In many cases a ½ liter glass is only about a ½ dollar per. The down side (or possibly upside) is that there is a ZERO tolerance policy for drinking and driving. Once you have had a drink you are committed to walking or finding a cab. Certainly if you were the navigator this was not a bad plan as you can drink. It was there that we met some folks from Saab Sweden and had interest-



**A Saab 99 on the track.**

ing conversations about various Saab projects. Nothing secret was revealed but there is always something new to be learned from Saab people who work in Trollhattan.

Saturday was a nice day for Saabing and we headed for the Autodrom (race track complex). There was the usual confusion about an Opel trying to sneak in and mix with the Saabs but eventually they figured out that we were the crazy Americans who had traveled 6000 miles to see their show. The reason I said earlier that this was not the best event was primarily because there were few vintage cars present and almost no one selling little Saab tidbits. I had nowhere to spend my money. However there was a lot to do.

There was a skid pad driving school taught by a professional driver. This was not very interesting for the modern cars with ABS. It did show how well traction control and ABS do work on Saabs. The older ones learned how to control cars on

a slippery surface. Another learning experience was a 900 that had casters where the rear wheels should be and a steering wheel that worked backwards (opposite of normal). The nearly impossible task was to negotiate a set of cones. Fun to watch, frustrating to do. There was also a small go cart track set up where you could have some real fun with lots of throttle and left foot braking. After 10 minutes I felt that I had wrestled an alligator but the grin never left my face. You could also use a rally type instruction book to drive the "OLD" Masaryk track through the surrounding countryside. While they did have an English version no one could tell us where the "0" mile mark was to start from. Only a few ventured out

At about 5 in the afternoon the German Motorcycle club yielded the track to us. With only a few rules they let about 60 cars per group go out. Here is where meeting the Saab factory folks the night before



**A Saab model 94 (Sonett I) shown through the windshield of a Viggen.**

paid off. They had a brand new VIGGEN there, I had a brand new video camera and a OPEL. I convinced them that it would be better not to have an OPEL out there amongst the SAABS and that as a passenger, I could film the event.

Now, using a video camera and holding it steady in a Viggen going around a race track is an interesting experience. Since the Viggen, in its bright blue livery was quite a sight, I got to video all the cars going by who were trying catch a video of the Viggen. At one point, three of the museum cars hit the track. Erik was, of course, driving # "283" Monte Carlo car and was accompanied by a two stroke Sonett II replica of the Coupes de Alpes

rally car and the White Sonett I. While watching (and HEARING) these 3 cars play on the track it was most amusing to see the traffic bunch up trying to race or get close to Erik. There were some interesting moments while people fixated on Erik and not on what they were supposed to be doing.

On a side note, I mentioned the Silver Sonett II that is made up to look like the Coupes de Alpes rally car from the museum. This car had all the rally equipment including Plexiglas side windows and other tricks. As most owners of Sonett II's do, the first thing I checked for was the serial number. I wanted to know which of the 256 cars this might be. Mysteriously enough the serial numbers had strategically placed pieces of black tape covering the numbers. It was obviously a 1966 model, so it had to be a low number. Was it one of the missing cars? Inquiring minds wanted to know. As it turns out this was serial number 00025 that had been given to Bob Sinclair on the occasion of his retirement from being president of Saab USA. Bob traded the museum that car for a 1959 Saab 93 that could be driven in



**"Bob Sinclair's Sonett II", traded to the Saab Museum in exchange for his 1959 model 93.**

vintage rally events. The Sonett II was too new for that purpose so the museum got a nice Sonett to make this rally replica and Mr. Sinclair gets to drive in events like the California Millia.

Sunday was another warm and sunny day. There was a scheduled bus tour to one of the historical battle grounds and castle about 25km from BRNO for those that wanted a diversion from Saab events. Back at the track the Saab "beauty contest" (we call it a Concours D'Elegance) was taking place. While that was starting we had visitors from the Czech veteran car club that were out for a rally of their own.





**Czech Tatra: a combination of styling cues from the Saab 96, Jaguar Mark X, Citroen 2CV, and the Tucker.**

This included two-stroke Aero' made between 1929-1939, Tatras, and Skodas all made in Czechoslovakia. They did a tour around the track in grand style and then parked nearby to show off the cars. These cars are all quite unique with a heritage not unlike that of Saab.

The concours event did set what I believe to be a significant record. In 1996 at the Saab Owners' Convention in Kirkwood, a very nice Sonett III won its class in the Concours. That same car, having followed its owners from Canada to the UK, where they now reside, also won

first prize in the Czech republic. Glen and Doris Ellis, as far as I know, are the first ones to win a prize on two continents with same car and owner combination. They certainly were the pride of the English club contingent

Once the prizes were given out it was time to say goodbye to our friends, new and old, and plot the remainder of our tour of the Czech Republic. That travel log will have to wait for another time and place. Suffice it to say, again, if you haven't been there you REALLY are missing something. Next year there will be a rally starting from North Germany in Kiel and ending 5-6 days later in Lucerne, Switzerland where the main event will be held. If I had to choose between Czech Republic and Switzerland (and MONEY was of no object) it would be a very tough choice. I am sure the Swiss event will be first class and I certainly plan to be there. Lucerne is a beautiful spot with lots to do and a great train museum. So save your pennies now, the chocolate is not cheap.

*Photographs by the author.*

**NOKIAN HAKKAPELIITA  
WINTER TIRES**

**www.snowtyres.com**

- 185/65-15T Hakka 1 (set of 4) \$275
- on steel wheels 900 88- (4) \$470
- on wheels 900; to 1987 (4) \$525
- 185/65-15Q Hakka Q (set of 4) \$300
- 195/65-15T Hakka 1 (set of 4) \$295
- 195/65-15H NRW H (set of 4) \$310
- on wheels 9000 (set of 4) \$510
- 205/55/16T Hakka 1 (set of 4) \$465
- 165-15 NR09 (set of 4) \$230
- 185/65-15T NRT2 all season \$59

*MANY OTHER SIZES ALSO IN STOCK*

**GISLAVED NORDFROST**

- Bentley Manual 900 8 valve \$27
- Mann oil filters (black) (10) \$37
- with purchase of 4 tires, limited

**G & G SERVICE**

**4073 HUBERTUS RD  
HUBERTUS, WI 53033**

**414-628-1716**

**DISC, VISA, MC & AMEX**

**900 - 9000 - 9<sup>3</sup> - 9<sup>5</sup>**



**English - Swedish Car Spares Ltd.**

345 Branch Drive SW - Alpharetta, GA 30004

*Largest collection of Recycled Saab parts in the South*

**1-800-241-1916**  
770-475-2662 Local  
770-475-2663 Fax

Visa - M/C  
Disc - Amex  
COD  
UPS - Motor Freight

New Arrivals Daily  
Fair Pricing  
Call for Quotes  
*Now carrying Volvo parts, too*



## Life at the top

As I stand and look at the awe-inspiring void of the Black Canyon of the Gunnison, I'm rendered speechless by its incredible beauty, struck dumb by the most impressive display of nature's power I've ever seen.

No, wait. It's not the amazing canyon that's making me feel this way. It's this incredibly thin air. At over a mile and a half up, I can't breathe to save my life.

This is gonna be one hell of a ride.

I've just joined the Nines Run the Rockies tour, a six-day pre-Saab Owner's



**Black Canyon**

Convention spectacle put on by the same tireless folks who hosted this years con, the Rocky Mountain Saab Club. The tour started on a sunny Saturday morning in Estes Park, Colorado, the gateway to Rocky Mountain National Park and gathering point for Saabs from every part of the free world. Everything from a '65 stoker to a shiny new Viggen took up the challenge, with drivers from places like New Zealand, Denmark and Germany driving, dragging or renting Saabs of their very own for the trip.

Although I missed the first two days of the tour, I made up for it with my very own cross-country adventure, a tale that will surely drive my kids crazy one day. I set out early in the evening of August 7 from Milwaukee, where I had been attending a convention for work. With the 9000 loaded to the gunwales with camping gear and provisions, my intention was to smoke

across the interstates as fast as I could get away with until I hit the lovely burg of Lincoln, Nebraska, there to spend the night. What I failed to realize was that this was a busy weekend night in the middle of vacation season; needless to say, every hotel room within 50 miles of I-80 in Nebraska was booked, at least that's what the frazzled young lady at the Motel 6 said. Well, I was feeling pretty good at this point, so I decided to press on after a quick hour catnap at a smelly I-80 rest stop.

Nearly two thousand miles, five states and almost 24 straight hours of cruising, I pulled into the Holiday Inn parking lot in Montrose, site of Sunday evening's Tour meeting to strange looks and even stranger questions.

"You drove straight through? No stopping?"

"Yep, that's right. Where's the bathroom?"

"But you aren't supposed to be here until tomorrow, are you sure drove straight through?"

"No, I made it up just now as I was pulling in. I'm not kidding, will someone PLEASE point me to a bathroom?!?"

Fortunately the tour proved to be well planned and conceived, taking participants on a wild ride that ranged from the aforementioned Black Canyon, a national monument that puts its Grand cousin to shame, to Telluride and Vail, alpine ski playgrounds of the ludicrously rich and famous. Each Tour car got a nifty bag of goodies containing custom embroidered shirts and hats, buttons, maps, flyers and coupons to attractions we would pass, stickers both of the Tour logo and car ID numbers and more. Those car ID numbers came in quite handy, allowing those of us who hadn't yet been introduced to look up a car's occupants via a matching list in the back of the nicely done Tour Book.

Day Three started off with an early-morning jaunt to Black Canyon, where I got to feel the effects of the much-ballyhooed thin air for the first time. Since

the tour rarely dipped below six thousand feet and several times crested twelve, this lack of breathable oxygen made for interesting hallucinations after a quarter-mile walk to the canyon's rim. Where did that giant pink bunny come from, anyway? Nights weren't any better, since sleeping at high altitude tends to make your body wake up with a jolt often, thinking that you'd stopped breathing in the middle of the night for some reason. Weird.

A wonderful drive down Routes 550



**Clockwise from Top Left: Utah, Colorado, New Mexico, and Arizona at the Four Corners. Center inset: The author covers four states with his body.**

and 62 followed, taking my loyal steed and I through high country forests riddled with spectacular mountain views and wildlife to dodge on the roads. A quick detour east took us to Mt Telluride, where weather permitting you can ride a free gondola up and over the mountain into Telluride itself. The weather didn't permit on the first leg, but the free shuttle bus service was on hand to take us to town in the drizzle. Telluride is a cool town, but don't expect to set up shop there unless you've just won the lottery: rents were higher than Manhattan co-ops, and real estate values shared a special affinity for altitudes with the surrounding mountains and their loftiness. Built in a dead-end valley, Telluride gets all its electric power from the oldest AC generating station in the country built under the waterfall at the end. A gravel road leads up there, for the few off-roaders who feel lucky, but rumor has it a certain orange Sonett made the trip unharmed. Still waiting for the pictures on that one....

The road eventually ended in Cortez, far away in the southwest corner of the state and perilously close to Four Corners. As the only place in the US where four states meet, Four Corners held a special fascination for me since I was a young pup, and being a mere forty miles away was just



too good a side trip to pass up. After checking into that night's meeting hotel, I rounded up a pile of hardy souls for the quick jaunt to stand on four states at once. What a blast! The desolate landscape was only broken by the occasional Indian casino or trailer park, beautiful and serene in its own strange way.

Day Four started out with a quick jaunt to Mesa Verde National Park, a disappointing tourist trap that drained the wallet of fifteen bucks and failed to deliver on many fronts. The place was crawling with RVs packed with screaming kids, all of whom were in line to get tickets to see the most popular houses, all of which were sold out long before any of us got there. Self-guided tours are possible, but with narrow roads crammed full of parked campers and limited views of the mesa houses, I wasn't much impressed. Fortunately I had planned my very own side tour, a three-hour run back through Cortez and into New Mexico, where I got to see the elusive Ship Rock up close and personal. By nightfall I had rejoined the group in Durango, site of our fourth bivouac and starting point of the wonderful Durango-Silverton railroad.

Our meeting that night was capped by a hilarious presentation to the Tour organizers from the German Saab club attendees, complete with miniature Saabs molded from tasty marzipan. What will those Germans think of next? My campsite that night was cut in two by the railroad, and I was duly warned at the front desk that the first train came through at 6AM, so be ready to wake up. No kidding. Nothing quite motivates one to get out of the tent quite like the rumbling and belching of a fully laden steam locomotive cruising by fifty feet from your sleeping bag.

Day Five began with a walk around



Old and new means of locomotion.

### High Altitude Driving: Learning the Hard Way

*We were going down the mountain faster and faster, and my husband said, "There's no brakes!" I screamed the whole way down, imagining that my husband, our daughter Tanya, our friend Greg and I would surely be killed. Fortunately we were able to get the nearside wheels into the gravel beside the road and this, together with Greg's energetic pulling up on the handbrake lever stopped us without damaging the car - or us.*

This was the way Val Plucknett described her memory of the Nines Tour of the Rockies, the road event which for many was the beginning event of the Saab Owners' Convention. The Plucknett family had included the Owners' Convention in their family vacation from their native England to the United States with. Driving a borrowed 1966 Saab 96 Monte Carlo, they encountered the combined effects of high altitude, long, steep downhill grades, and a single driving error which could have resulted in a tragedy.

The boiling point of brake fluid, the same as other liquids, is dependent on the atmospheric pressure to which it is exposed. People who live at high altitudes know that cooking instructions must be altered. In particular, boiling things in water is often an exercise in patience, because the boiling water isn't all that hot! Water which boils at 212 degrees at sea level has a much lower boiling point at the 10,000 foot altitude where the Tour of the Rockies spent much of their time. The boiling point of brake fluid is much higher than water, but brake fluid also absorbs moisture. The more moisture is absorbed, the lower the effective boiling point. The reduced atmospheric pressure at high altitudes lowers the boiling point even further.

As a car is descending a long, steep grade, the energy released by the downward movement is partly converted to heat in the brakes. If the brake fluid temperature reaches the boiling point, as soon as the brake pedal is released the fluid in the brake cylinders will be expelled back to the master cylinder reservoir, leaving only air in the wheel cylinders. The next time the driver tries to apply the brakes, the pedal goes straight to the floor. In the case of the borrowed 96, Neil had been advised to keep the 96 in second or third gear while descending the grades, and to keep the "freewheel" mechanism locked. But Neil became concerned about over-revving the engine on the downgrades, and so he had released the freewheel. To keep the brakes cool, he used the time-honored practice of braking hard then building up speed and cooling the brakes down before repeating. The process had worked well up until the point where they got stuck behind an R.V. riding its brakes down the grade in question. Without any engine braking at all however and with the Saab 96's excellent aerodynamics, low rolling resistance, and the full load of family and luggage, the amount of heat generated in the brakes was finally too much. "The ridiculous thing," said Neil, "is that I had been pulling over and stopping on a regular basis for about 30 minutes at a time to let the brakes cool down. Unbeknownst to me, the last time I did this the fluid had actually boiled out of the calipers. And so, when we pulled out of the lay-by again without checking the brakes the wild ride was on."

The lesson from this story is the importance of being extremely cautious when driving in unfamiliar conditions. The same story, but with different words and places, can describe a life-long sun-belt resident spending a winter up north; a regular American "double nickel" (55 mph) driver, accustomed to cruising the Interstates with a cup of coffee in one hand and a cell phone in the other, driving 100 plus on the Autobahn; or any one of us driving "on the wrong side of the road" in Neil's England.

*A booklet entitled "Manual for High Altitude Driving" was prepared for the Nine Tour of the Rockies. We will attempt to put a copy of it on our website at <http://www.saabclub.com>. Anyone who wants can also receive a copy by email from us can receive one by posting to [nines@neo.rr.com](mailto:nines@neo.rr.com).*



Durango, once a gritty mining and logging town but now prettied up for all the big-city money, complete with cell phones in every hand and trendy shops on every corner. The coolest attraction in town was the Durango Auto Museum, a private collection of gorgeous Packards, Studebakers and more, all meticulously cared for, driveable and very much for sale at the right price. The guys who ran the place had just gotten back from my hometown of Middletown, Ohio, with a pristine '53 Buick Roadmaster that belonged to a gentleman I knew growing up. Small world, awesome car collection.

After the drool had subsided, it was off to Silverton to pick up those who had ridden the train. North of Silverton marks the entrance to the Million Dollar Highway, so named because a million bucks couldn't entice me to drive that road again. Well, okay, maybe. Possibly the most harrowing

from a challenge, I decided to show this upstart who was boss and proceeded to up the pace a bit, bumping up the speed to ludicrous and hanging the tail out over the 1000-foot-drop corners for all the 9K was worth. But still the wagon held tenaciously on. Near the top, we pulled over behind a lagging 9K to take a picture, when much to my chagrin I discovered the driver of the wagon was none other than Erik Carlsson himself.

Whoo boy.

He seemed nonplussed by the performance, however, and proceeded to lead the way back down the other side of the mountain. Followed closely by a maroon 9-5 sedan that had previously been hidden in our dust, the wagon leapt ahead, and I pursued. We passed perhaps a dozen of our fellow tour mates on that insane ride down, never letting up on the gas and barely getting away with my sanity intact. But I have to admit: I have never before in my life had so much fun behind the wheel! At the meeting that night in Crested Butte, Erik congratulated me on my driving skills, which I modestly passed off as nothing more than braking when he had, turning when he turned, that sort of thing. No, really Erik, it was all your

fault. But did you REALLY think I was that good? Aw shucks.

Our last night together in the chilly ski town of Crested Butte wrapped up with a sumptuous meal at the Marriott, followed by speeches and awards presented all around, a fantastic time to be had by all. The next morning we drove over our highest point on the tour, 12128 foot Cottonwood Pass, then descended on Vail for shopping and lunch before our final rally point in Dillon, just three miles from the SOC in Keystone. A quick trip through the car wash, tires wiped all around and away we were, in one huge grand caravan to enter the parking lot at Keystone in grand style!

My thanks go out to all the hard work



**Erik Carlsson drove on ahead to greet and congratulate each participant at the conclusion of the tour.**

and dedication put forth by the Rocky Mountain Saab Club, specifically Rich Hruda, Bruce Harbison, Jerry Danner, Tom Nelson and all the others who made the Rockies Run such a memorable event. Thanks for the trip of a lifetime guys, after 4,956 miles in eleven days I can certainly say I earned it!

*Photographs by the Author*



**A Saab 96 looks over the "hangar queens"**

collection of switchbacks, blind corners and impossible grades ever assembled by man, this road is quite simply not for the faint of heart (or the thin of brake pad) but provides more fun than an hour stuck on a roller coaster.

Not long after exiting the Million Dollar Highway, our tour took us past the town of Ouray and its hot springs to Owl Head Pass Road. Don't let the name fool you: this "road" was nothing more than a timber trail full of washboard ruts and loose gravel winding up to 11, 120 foot Owl head Pass, a 40-mile torture rack for suspensions and dental fillings alike. Sounds like fun, let's go! After a few minutes, however, I noticed a silver 9-5 wagon was on my tail and holding tight. Not one to back away

For the Friendly,  
Helpful Service and  
Genuine Saab Parts  
you've come to expect,  
call:  
**1-800-705-SAAB**  
or  
**1-609-924-5101**  
**SPORTS AND  
SPECIALIST CARS**  
  
1023 STATE ROAD  
PRINCETON, NJ 08540  
  
Authorized **SAAB** Dealer  
  
fax: 609-924-8461  
E-Mail: [sns cars@aol.com](mailto:sns cars@aol.com)



## SPORTS CAR SERVICE, INC.

Home of Sonett I No. 6

Visit our website at

<http://www.sportscarservice.com/>

### Ricochet Headlight Protection

Clear headlight shields

20 mil vinyl, laminated acrylic coating.  
Optically clear. Guaranteed not to yellow.

Install in minutes. Pre-cut to fit.

\$29.95

\*\*\*

### Cup and Coin Holder For 9000's

Replaces the ashtray and cigarette lighter

Holds two cups or cans

Looks built in. \$68.00

\*\*\*

### Dash Designs

Carpet dash covers for 900

Black only. \$36.95

Rear deck covers for 900 hatchback  
available in tan, red, charcoal, and navy.

\$39.95

\*\*\*

### Tee Shirts!

"Friends Don't Let Friends Drive Fords ...  
SAAB"

and

"Life is Too Short To Be Driving Chevys...  
SAAB"

L, XL, XXL \$19.00

\*\*\*

### Comfy

Finest natural sheepskin seatcovers

1" thick selected pile

A masterpiece of affordable luxury

\$175.00 per seat

\*\*\*

## Roof Top Carriers

By **THULE**

**Bike carriers, ski racks, sailboard,  
snowboard, kayak or canoe carriers all  
fit the same roof bars.**

**Locking items may be keyed alike.**

10% off list.

\*\*\*

### ZYMÖL

**PURE, POWERFUL, PERFECT**

Saab Wax \$35.00

**Sale! Vinyl Treatment 5 oz. Only \$13.00**

Strik Oil & Grease Remover \$25.00

Other Zymöl products available.

\*\*\*

Order by phone: 1-800-saab130

fax: 302-764-7454

Mail: Sports Car Service

3901 N. Market St.

Wilmington, DE 19802



The 1999 "Master Tech Challenge" and the 1999 "National Technical Training Convention" were held concurrently with the 1999 Saab Owners' Convention at Keystone. As reported in NINES #240 (July, 1999) attendance at these events was by invitation from Saab Cars, based on test scores achieved by Saab technicians. The Master Tech Challenge was conducted in a set of six tents, where "problems" were presented to the contestants. Each contestant had about an hour to complete each task. The problems were devised by Saab's Technical Trainers, based on the tools and techniques they teach and feedback from the field. Thus, the competition highlights not only the abilities of the individual technicians, but also the kind of service ability which Saab is training into its dealers' technicians.

### What's wrong with this car? What car?

At station 1, there was no car! Imagine you are a service tech, and the tech savvy Sales Manager of the dealership presents you with this problem:

"A customer came in Saturday with a 9000 that intermittently runs crappy. He couldn't leave it, but he will be in tomorrow over lunch and he wants you to fix it then." So far this sounds like an impossibility, but remember, the Sales Manager is "tech savvy." Continuing: "I hooked up the Tech 2000 (Saab's computer diagnostic tool, which interfaces with the car's electronics) and we ran it down the road. First it was fine, and I took a 'snapshot'.



Using the Tech 2000, a technician can diagnose the car using stored data. The car need not be present.

Then when it went bad, I took another. Here's the data."

The test station contained a Tech 2000 tool, in which data consistent with the above scenario had been loaded. In this case, the car was "sabotaged" by pulling the hose from the turbocharger's wastegate actuator. This meant that the engine controls were unable to limit the boost pressure. From looking at the data when the car was running poorly, and comparing it to when the car was running correctly, a technician could observe that Saab's "Trionic" engine management computer was doing everything it could to prevent damaging engine knock: adjusting the engine timing, injecting excess fuel, and attempting to reduce the boost level. All this would indicate to the technician the general nature of the problem: no control over the boost pressure.

### What is that, and what do you call it?

Station 2 consisted of 2 separate tests. On one side was a table of special Saab service tools, some dating back to Saab 99 and 96 models. Often having access to a "special tool" is the difference between a short, easy (and relatively inexpensive for



Special tools can make servicing a Saab easier.

the owner) repair and one that is a trial.

The second table was a "match up" test, with "commonly used terms" for various signals and functions of the car and their "Official SAE (Society of Automotive Engineers) Designation." Knowledge of the official designation is vital to a modern technician because all the training and service materials must use only the SAE terms. This standardization of terms has been accepted across the entire automotive industry.



### The sun is shining, but my top won't go down!

At station 3, the technicians were presented with a Repair Order stating just that, and a 9<sup>3</sup> Convertible which had been sabotaged accordingly. To get the maximum score on this test, the Technician must first verify the complaint, then attach the Tech 2000 tool and check for error codes. Of course, the error code simply stated: "Illegal Input State." From that point, it is a matter of using the service manuals and training information to logically deduce the nature of the problem, then find it.

### Just a couple of questions...

Being able to repair problems is not necessarily sufficient to ensure the level of service quality that Saab wants its customers to receive. At Station 4, the trainer poses as a customer who has just purchased a new Saab and has "a couple of questions." The scenario has the customer being a repeat buyer who wants to know what differences there are between the last Saab and the new one. The questions center on the settings which can be made

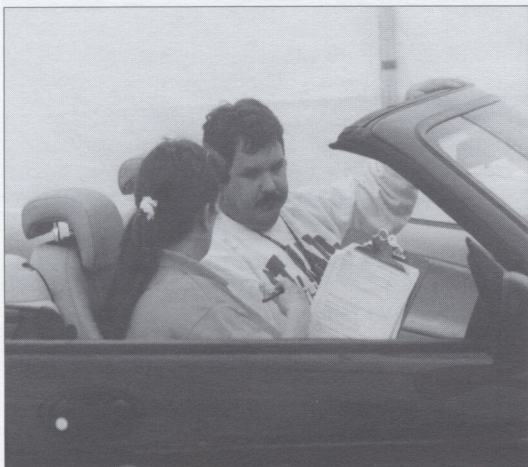

**A technician explains the features of a 9<sup>3</sup> convertible to an instructor/judge.**

using the Tech 2000 tool, such as the calibrations of the temperature gauge and the fuel gauge. The trainer also requests some settings which are not permitted. While "correctness counts", the main purpose of this station was to test customer relation skills.

### You think your car does weird things?

At station 5 I was reacquainted with Rich Miller, who was District Representative covering Northeastern Ohio when I bought my first Saab, and is now a 9<sup>5</sup> and 9000 Product Specialist. The car at this station was a 9<sup>5</sup> which would keep running even with the key out of the

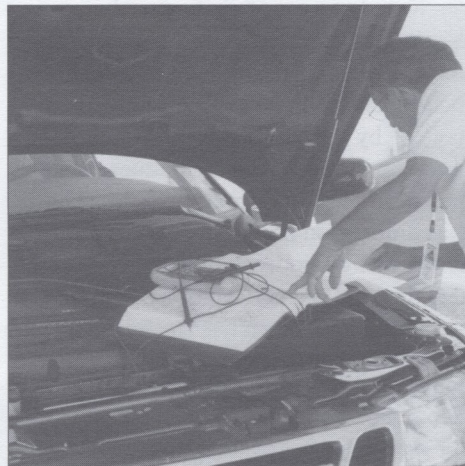

### Tracing the wiring in the 9<sup>5</sup> that would not stop running.

ignition, so long as the brake pedal was pressed. To achieve this result, a "short circuit" was created at the ABS connector, a point in the wiring harness where the brake light signal and the power lead to the Trionic computer are both present. By continuing to supply the "engine on" signal to the management computer, the engine naturally continues to run. Finding the flaw was partly a test of deductive reasoning: finding something in the braking system which could power the engine computer. It was also partly a test of familiarity with the wiring harness and wiring diagrams: being able to isolate those areas where the braking and ignition signals are physically close to each other.

### Build me a wiring harness.

At station 6, the technician was presented with a "DICE" (dashboard control computer), the appropriate

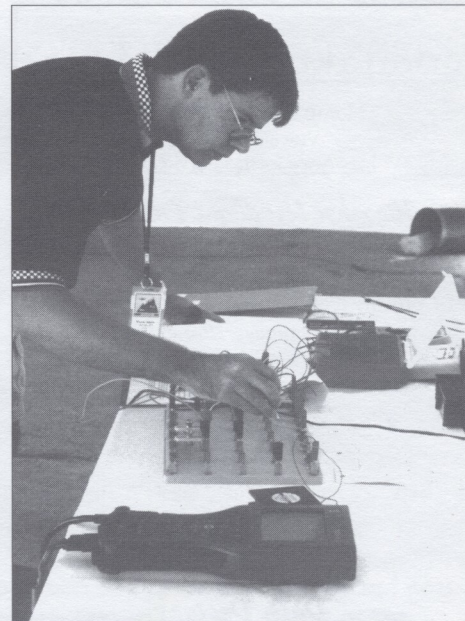

**Building up part of the dashboard wiring circuit using a "breadboard" and a "DICE" dash computer.**

connector with wires attached, and a "breadboard", or "tinker toy for electronics." Using the wiring diagram from the service manual, the test was to build up part of the dashboard circuitry, including the circuitry for the radiator fans, the fog lights, and the left-hand turn signal circuitry. After completing that task, the technician was asked to hook up the Tech 2000 tool and perform a set of diagnostic tests on the built-up circuit.

One clear trend from the Master Tech Challenge is that electronics, computer control and diagnostics, and the ability to comfortably work with electrical problems must be part of a modern repair technician's skills. This is not to indicate that traditional mechanical skills are not important. Rather, it's an indication of the transformation of the modern automobile from a purely mechanical device to one controlled and monitored by electronics.

It also highlighted the ability of these systems to monitor themselves and reveal, through the diagnostic tool, enough information to allow the systems to be diagnosed quickly and repaired without drama. This capacity for self diagnosis is the most exciting development that we see in the integration of electronics into the cars.



# Convention Contests: Autocross

by Stephen Goldberger

For many the Saab Owners' Convention is a time for relaxation, education, or comradery, but for others it is a time of friendly competition. At Keystone, prizes were awarded for the best results in Autocross, Concours, Photography, and Time - Speed - Distance (TSD) Rally. The prizes themselves were crafted as a Club Project by the Rocky Mountain Saab Club. A Ponderosa Pine which had succumbed to the an insect infestation was cut from the property of Tom Nelson, Convention Chairman and sawn to resemble the shape of a Saab 96.

Autocross is a timed race over a closed course, usually a fairly short one laid out in a parking lot. The course is marked by rubber traffic cones, and cars race individually. The shortest net time is the winning time, but a 2 second penalty is assigned for each knocked over cone and deviation from the course results in that run being disqualified. The course typically emphasizes vehicle handling properties and driver skill over horsepower. As seen in the attached winners' list, the very best time was achieved by a 2-stroke Sonett II, one of the lowest horsepower entrants.

A word about the "OTHR" class. The Autocross was conducted using the personnel, equipment, and expertise of the Pike's Peak Sports Car Club. Nick Wilson, overall winner in his Sonett II, was the leader, and any other PPSCC member who helped conduct the rally was invited to participate on a "non-trophy" basis. Not all of the "other" class competitors were from PPSCC. Last place in that class, and last place overall, belonged to an unnamed Saab employee driving the "Red Dodge Company Van."

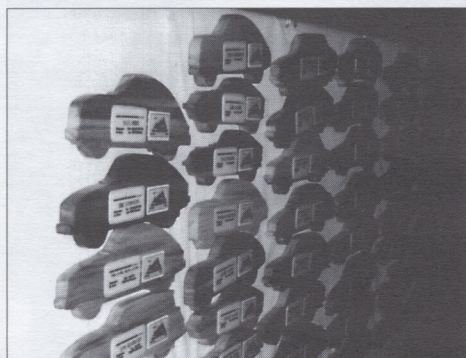

Table of trophies - hand made by the Rocky Mountain Saab Club from Ponderosa Pine.

#	CLASS	DRIVER	CAR	PENALTY(SEC)	TOTAL(SEC)
(MODIFIED SONETT, 93, 95, 96)					
9	M1	NICK WILSON	SONETT 2 WHT	0	0:39.165
90	M1	JOHN WIRT	SAAB 99	0	0:40.909
6	M1	CAROL ANNE FREEMAN	SONETT 2 WHT	0	0:42.970
(MODIFIED 99, 900, 9000, 9, 9 <sup>5</sup> )					
95	M2	MIKE LEE	900T WHITE	0	0:41.371
2	M2	DAMIEN SHULOCK	900 SPG GREY	0	0:43.169
1	M2	PAUL KALINOSKI	9000T RED	0	0:43.454
(OTHER - NOT SAABS)					
76	OTHR	KEN ENNIS	69 CAMARO BLK	0	0:41.706
7	OTHR	SCOTT CAMPBELL	69 CAMARO BLK	0	0:43.100
17	OTHR	ROBERT GARDNER	BMW 2002 74	0	0:46.648
(STOCK SONETT, 93, 95, 96)					
1	S1	KEVIN DICKSON	SONETT 3 ORNG	0	0:45.319
4	S1	THOMAS WENNER	SONETT 3 RED	0	0:46.501
3	S1	OLLE ANDERSSON	SONETT 3 ORNG	0	0:49.769
(STOCK CLASSIC 900, 99)					
13	S2	SEAN MULLADY	900T BLACK	0	0:42.954
10	S2	JOSHUA STEIN	900T BLUE	0	0:43.775
14	S2	ROBERT M FARRELL JR.	900 SILVER	0	0:43.988
STOCK 9000, NEW GENERATION 900, 9, 9 <sup>5</sup> )					
10	S3	FLOYD RUSSAK	9000 CSE	0	0:44.299
8	S3	RANDY KELLY	94 AERO	0	0:45.475
2	S3	BRUCE BILLING	97 900T BEIGE	0	0:45.748

If the Autocross is "all go and no show," then Concours is just the opposite. Cars are judged on neatness and conformity using a "points deducted" scale. In general, each car entered in the Concours left the factory with "maximum points", with point deductions being made for dirt, leaks, damage, the installation of "aftermarket" devices, and such indignities as lost owners manuals or an improperly stowed jack. We will print the rules in the March, 2000 issue of NINES for interested members preparing for the year 2000 Owners' Convention Concours.

CLASS	MODEL	YEAR	WINNER	MODEL
A	92		NO CARS ENTERED	
B	93&96	57-64	1. ERIC JOHNSON	RED 1960 96
			2. PAUL PERRY	BLUE 1960 93
			3. MARTY ADAMS	BEIGE 1964 95 WAGON
C	95&96	65-68	1. JOHAN KJAERULFF	GREEN 1966 96
			2. TERRY CASPER & REGINA ACCORN	RED 1968 95 WAGON
			3. —	ONLY 2 CARS ENTERED —
D	95 & 96	69-73	1. TOM DONNY	WHITE 1970 95 WAGON
			2. ANNETTE ADAMS	RED 1972 96
			3. JERRY DANNER	BEIGE 1972 96



## Convention Contests: Concours

### CONCOURS SCORES CONTINUED

CLASS	MODEL	YEAR	WINNER	MODEL
E	SONETT	2/STROKE	-67	
		1.	DALE HOLMES	RED 67
		2.	CHIPS BARRY	SILVER 67
		3.	STEVE NICHOLF	YELLOW 67
F.	SONNETT	V-4	67-69	
		1.	PAUL PERRY	RED 68
		2.	BARRY NASH	BLUE 69
		3.	INSENER EKSTROM	BLUE 68
G.	SONETT	III	70-74	
		1.	SHARON SIEGEL	BLUE 74
		2.	BUSH QUACKENBUSH	BLUE 73
		3.	BARRY SIEGEL	RED 74
H.	99		69-80	
		1.	BRUCE HARBISON	MAROON 78 EMS
		2.	PATRICA DONNEY	GRAY 78 TURBO 3DR
		3.	KATHY SNIDER	YELLOW 73 2DR
J.	900		79-86	
		1.	TAD GILLIAN	ROSE 86 900S
		2.	GARY GRIMES	GREEN 83 900 T
		3.	BOB BUCK	WALNUT 900T 3DR
K.	900		87-93	
		1.	MARK KLINE	WHITE 87 900T 3DR
		2.	JAMES TYSON	GRAY 89 900 SPG
		3.	DAN PELPKO	RED 89 900 SPG
L.	900		94-	
		1.	BRUCE BILLINGS	BEIGE 97 900 SE
		2.	CHARLES EDWARDS	BEIGE 97 900 SE
		3.	— ONLY 2 ENTRIES —	—
N.	9000 5DR, CD & CDE		86-94	
		1.	JIM BEETHAM	CHAMPAIN 89 9000 S
		2.	JOHN PLANKEY	BLACK 87 9000 T
		3.	DAVE HAGARTY	BLACK 87 9000 T
P.	9000 CS, CSE, AERO		93-98	
		1.	JERRY WETTERHORN	GREEN 97 9000 CSE
		2.	DAVID YOUNG	BLACK 94 AERO
		3.	SANDY UHL	RED 93 9000 CSE
S.	CONVERTIBLE	900		85-94
		1.	CHRIS FARRINGTON	BLACK 93 900 S
		2.	CARL KINGERY	BLACK 88 900 T
		3.	DONNA KLINE	TEAL 91 900 T
T.	CONVERTIBLE			95-
		1.	KEVIN HENERY	YELLOW 97 900 T
		2.	RUTH SUTTON	TALADEGA SILVER 900 T
		3.	— ONLY 2 ENTRIES —	—
M.	MODIFIED			ALL
		1.	TODD CAMPISANO	GRAY 88 900 SPG
		2.	PAUL KALINOSKI	GRAY 88 900T
		3.	GREG JENSON	73 99 2DR YELLOW
PEOPLES CHOICE			RANDY WILLIAMS	RED 1959 93
BEST OF SHOW			BRUCE HARBISON	MAROON 77 99 EMS

### The Photography Contest

If a picture is worth a thousand words, as the saying goes, then the attached reproductions tell the story of the Photography contest.

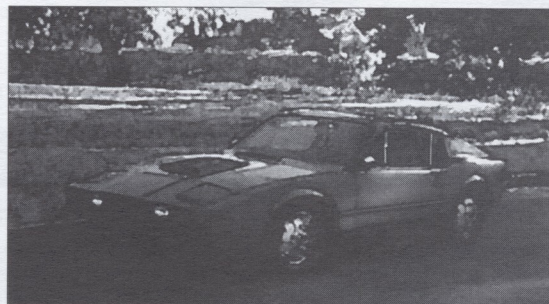

**First Place: Car Portraits. Red Sonett III watercolor effect. Greg Russell, Aurora, Colorado.**

*Note: the original photograph was in color, with watercolor brush strokes added to give a hand-painted look. This reproduction hardly does justice to the original.*

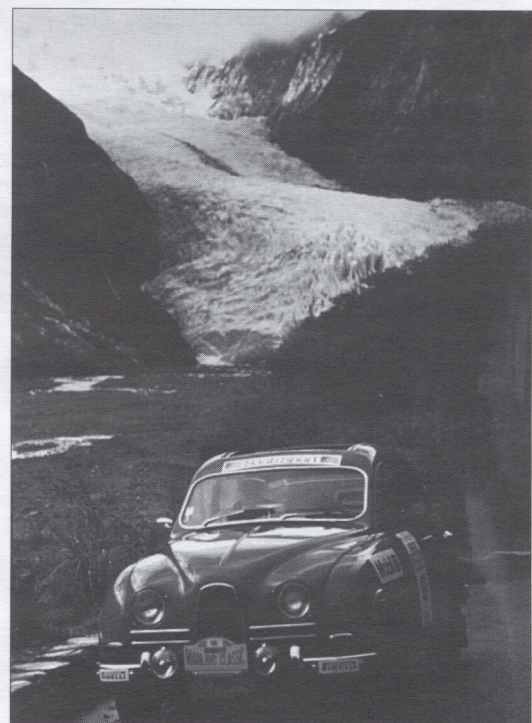

**Second Place: Car Portraits. Red 96 Rally Car with Glacier. Geoff Ridley, Christchurch, New Zealand.**



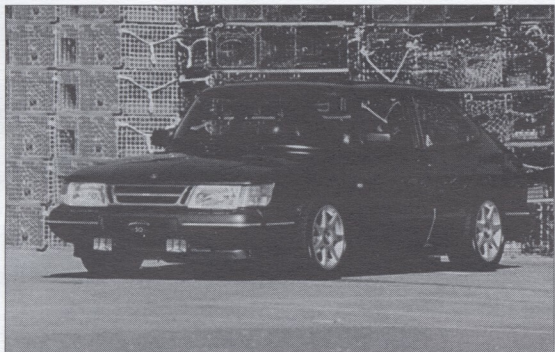

Third Place: Car Portraits. Black 900 with Lobster Traps. John del Rosario, Manchester-by-the-Sea, Massachusetts.

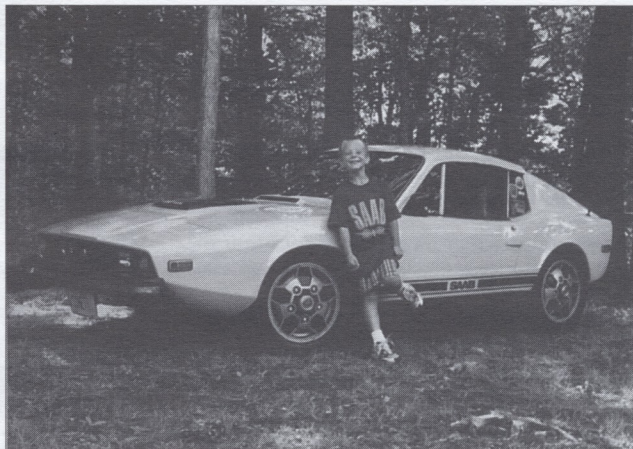

First Place: Snapshots. Yellow Sonett III with boy. Bruce Turk, Walden, New York.

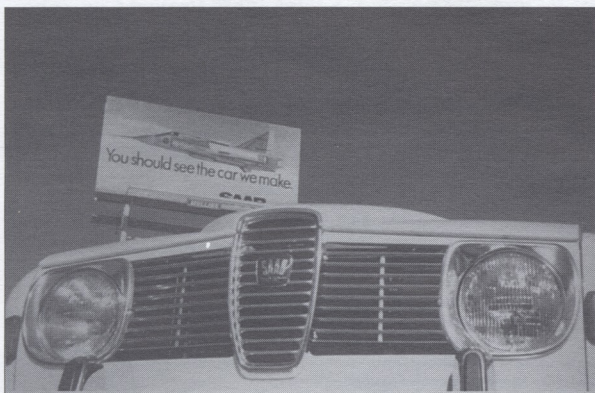

First Place: Impressionistic. 96 front with Viggen billboard behind. Mats Sjodin, Denver, CO

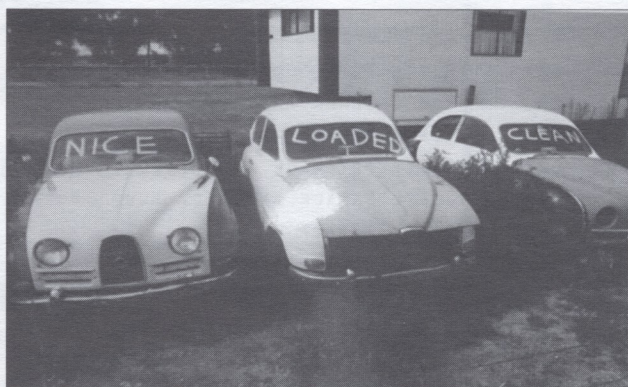

Second Place: Snapshots. Three 96's: "Clean, Loaded, Nice". Don C. Baker, Albuquerque, NM.

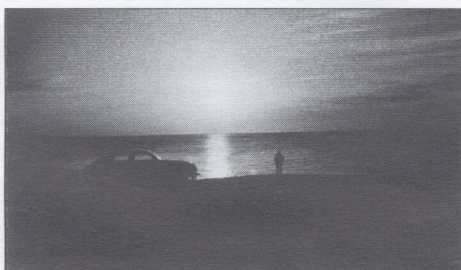

Second Place: Impressionistic. 96 Silhouetted at Sunset. Martin Hilvers, Tolbert, Netherlands.

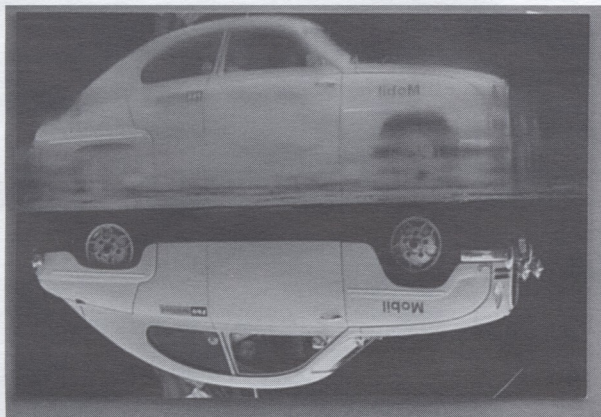

Third Place, Impressionistic. Yellow 93 reflections. Geoff Ridley, Christchurch, New Zealand.



Third Place: Snapshots. Black 900 Camping in Canada. Jason Strauch, Albuquerque, NM.



## Convention Contests: Rally

A TSD Rally would seem to be the simplest kind of road race imaginable. Driver and navigator are given printed instructions telling them where to turn and how fast they should drive. In the "low stress level" Convention rally the instructions were further augmented by including the mileage between turns. Using straightforward mathematics, the navigator can convert the mileage at each instruction to a time, allowing the team to easily correct for the vagaries of traffic and traffic lights. The score is based on the time at which the team arrives at a checkpoint. One "point" is awarded to the team for each second's deviation from the "ideal" time for arriving at the checkpoint,

and just like golf, the low score wins.

That is the theory. In practice, rally scenes often contain two contestants driving as fast as they can in opposite directions in a futile attempt to get back "on course." The 1999 Owners' Convention Rally contestants were divided into classes, based on the level of experience and the equipment contained in the car. But a sharp eye, dogged adherence to the instructions, and perhaps a smidgen of luck can be much more valuable than experience or equipment. R. Scott V. Paterson, the founder of The Saab Network, an internet Saab interest site and e-mail list, and his partner David Young, running in the "Novice" class, achieved the best score of the day.

One final "contest" was a contest of the pocketbook. In the Presenter's Auction, those who rented exhibition space and others donated items to the Rocky Mountain Saab Club for auction at the Welcome Barbecue. Proceeds from the auction went to the Rocky Mountain Saab Club to help defray the expense of hosting the Convention. The lead-off item for the auction was "The Cover of NINES". Mark Kline, who graces the cover of this issue, was high bidder.

The highest priced item in the auction was a Saab 900S, which was the Rocky Mountain Saab Club's Project Car. The car had been donated to a charity by its former owner. Through the good offices of Jerry Danner and Mile Hi Body Shop,

CAR #	OCCUPANTS	CLASS	CTRL#1	CTRL#2	CTRL#3	CTRL#4	TOTAL
125	DEREK FLETCHER AND INGEMAR EKSTROM	EQUIPPED	8	9	61	129	207
87	ROB GARDNER AND CARL NATION	EQUIPPED	74	19	1	116	210
553	LESTER EWING AND KEVIN QUIGLEY	EQUIPPED	1	300	6	47	354
423	SCOTT PATERSON AND DAVID YOUNG	NOVICE	28	1	24	21	74
107	JESSE STRACK AND SUSY RUOF	NOVICE	7	28	36	21	92
183	DIRK FEATHER	NOVICE	64	1	53	19	137
56	A. CHARLES AND MARY ANN PARRISH	UNEQUIPPED	20	24	22	13	79
424	DON YOUNG AND TOM REMEDIOS	UNEQUIPPED	15	59	19	6	99
446	JASON STRAUCH AND JOSHUA STEIN	UNEQUIPPED	30	69	1	8	108

For those who haven't had the pleasure of competing in a rally, and think it might be fun, we have duplicated the first few instructions from the 1999 Saab Owners' Convention Rally. "CAST", which stands for "change average speed to" is blank here because this is the "odometer check", which is not timed.

#	CAST	MILEAGE	MILEAGE	TIME	PAUSE	INSTRUCTION
1		0.00				THE ODOMETER CHECK SECTION BEGINS AT "SAAB RALLYE START". CONTINUE OUT PARKING LOT ONTO STREET. YOU HAVE 30 MINUTES TO COMPLETE THE ODOMETER CHECK SECTION, WHICH ENDS AT INSTRUCTION #23.
2		1.04				LEFT AT TRAFFIC LIGHT (US HWY 6)
3		1.11				SPEED LIMIT 45
4		1.64				"LAND FILL"
5		2.77				LEFT AT TRAFFIC LIGHT (TOWARD BRECKENRIDGE)
6		2.95				SPEED LIMIT 35
7		4.08				"LOWRY"
8		4.62				"LOWRY", SIGN ON LEFT
9		4.79				SPEED LIMIT 30
10		5.82				"SAPPHIRE"
11		7.71				RIGHT AT TRAFFIC LIGHT (STA HWY 9)
12		8.06				SPEED LIMIT 50
13		9.08				"FRISCO"
14		9.59				"PEAK ONE"
15		9.80				"95"
16		10.31				TRAFFIC LIGHT
17		10.37				SPEED LIMIT 40
18		10.82				TRAFFIC LIGHT (MAIN STREET)
19		11.17				TRAFFIC LIGHT (SCHOOL ROAD)

Club members repaired and detailed the car into fine condition, and the high bidder acquired a bargain and a conversation piece. The total net proceeds from the Presenters' Auction was about \$4,500, which all but guarantees that this event will become a permanent fixture for future Conventions.



Marla Danner demonstrates a wood rim steering wheel while Ron Powell urges on the bidding.





**SAAB**  
FIND YOUR OWN ROAD

FACTORY TRAINED SAAB PARTS PROFESSIONALS – BEST IN THE BUSINESS

Why Advertise Specials –

ALL OUR PARTS ARE SPECIALLY PRICED

FREE FREIGHT ON FIRST ORDER  
OVERNIGHT SHIPPING AVAILABLE

Call Mike , Al, Dave or Bill and find out first hand how much you can really save and put the profit back where it belongs

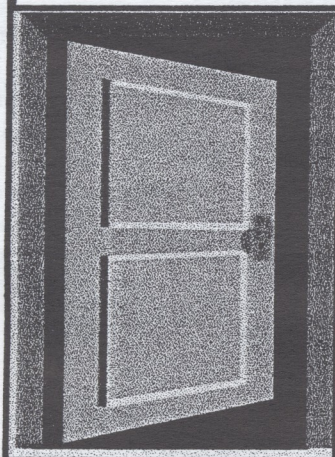

LET US HELP YOU TO  
OPEN THE DOOR TO A NEW WAY OF  
BUYING FACTORY REPLACEMENT PARTS  
AND ACCESSORIES FOR YOUR SAAB.

HOURS – Mon.-Fri. 7:00 AM til 5:30 PM  
Sat. 8:00 AM til 4:00 PM  
Times shown are Mountain Standard Time

“WE MAKE IT EASY”

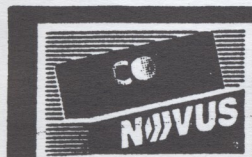

WE ACCEPT

PHONE 1-800-876-5199 FAX 1-602-200-1192  
OR CONTACT OUR WEBSITE- [HTTP://WWW.CAMELBACKVW.COM](http://www.camelbackvw.com)

1499 East Camelback Road • Phoenix, Arizona 85014 • (602) 265-6600 • FAX: 263-9572



## Model Year 2000 9<sup>5</sup> Sedan and Wagon

Answering to a demand which was present among Saab enthusiasts from the time that the 9<sup>5</sup> was introduced to the United States market in the spring of 1998, and fulfilling an often whispered promise, Saab has brought a high performance variant of that model to market: the 9<sup>5</sup> Aero. Building on the heritage of the potent 9000 Aero, this sporty sedan features a high output turbocharged, 230 horsepower 2.3L 4-cylinder engine that is available with either a 5-speed manual or 4-speed automatic transmission. When mated to the 5-speed manual transmission, the 9-5 Aero engine develops 258 lb.-ft. of torque from 1,900 to 3,800 rpm. "Overboost" capability momentarily allows torque levels as high as 273 lb.-ft. in cars with manual transmissions. With an automatic transmission, the maximum torque is limited to 243 lb.-ft., which can be achieved from 1,900 all the way up to 4,600 rpm. The Aero, with its version of Saab's latest T7 model Trionic engine controls, features variable boost control to enable the engine to reach its full torque rating up to 10,000 ft. altitudes, and Saab's innovative drive by wire throttle control which all but eliminates perceived "turbo lag." The Aero's exterior and interior styling changes include flared rocker panels, a front chin spoiler, a rear valance and a sport steering wheel. Saab engineers have also integrated a sport chassis with performance-optimized suspension, upgraded brakes and 17-inch alloy wheels with low profile tires. For the 2000 model year, the Aero in the United States and Canada will only be available in a sedan body.



**1999 9<sup>5</sup> Sedan (left) and 2000 9<sup>5</sup> Aero (right)**

Aside from the introduction of the Aero model, the 9<sup>5</sup> product line features new standard equipment and a simplification in the range of available models. The Saab Traction Control System (TCS), which was previously available only as standard equipment on V-6 models, is now standard equipment on all 9<sup>5</sup> model. Saab's TCS is an "all-speed" system that modulates ABS braking and electronic throttle, when necessary, to prevent spinning of the front drive wheels. Saab also adds a sunroof, which was previously standard equipment on SE models and Wagons, as standard equipment on all 9<sup>5</sup> models.

In a return to the original market plan, 9<sup>5</sup> SE Sedans and Wagons will all be equipped with the 3.0L V-6 LPT engine and automatic transmission. That original plan had been revised after the introduction of the V-6 engine was delayed and Saab felt that having a higher trim model designation was important. SE models also receive a standard "electrochromic" automatic dimming rearview mirror. This device measures the light level through the windshield and compares it to light level reflected by the mirror. It then activates an electrochromic layer within the mirror to balance those levels. The 3.0L V-6 light pressure turbocharged engine

generates 200 horsepower at 5,000 rpm and 229 lb.-ft. of torque from 2,500 to 4,000 rpm.

Entry level 9<sup>5</sup> Sedans and Wagons in the United States will be equipped with the 170 horsepower 2.3L 4-cylinder light-pressure turbocharged engine. A Premium Package, which includes leather interior, the Harman/Kardon audio system, and memory function for the driver's side 8-way power seat will take the place of the 4-cylinder "SE" package which was available on 1999 models. Entry level 9-5 Sedans and Wagons will have a newly designed 16-inch ten-spoke light alloy wheel, while 9-5 SE Sedans and Wagons continue to be equipped with 5 spoke alloys.

## Model year 2000 9<sup>3</sup> Coupe, Sedan, and Convertible

For the model year 2000 Viggen line, 5-door and Convertible variants will be added to the 3-door, along with an extra boost of horsepower and torque for all Viggens. Saab's top performer now delivers 230 horsepower at 5,500 rpm and 258 ft.-lbs. of torque from 2,500 rpm to 4,500 rpm. All three Viggens (Coupe, Convertible and 5-Door) are now available in Black or Silver in addition to the Viggen exclusive Lightning Blue. Monte Carlo Yellow, which had been proposed for model year 2000 and which was conspicuous on a Viggen 5-door prototype at the 1999 Saab Owners Convention, will not be available. Fewer than 3,000 Viggens will be produced for the world in model year 2000, with 1,000 of them coming to the U.S. market.

5-Door and Convertible 9-3 SE models' "HOT" engine output is up to 205 horsepower. Manual transmission equipped versions of this engine continue to provide maximum torque of 209 lb.-ft. from 2,200 rpm to 4,800 rpm. Automatic transmission equipped SE models are now equipped with the High Output Turbo developing a maximum torque of 184 lb.-ft. from 1,900 rpm to 5,700 rpm. The 9-3 SE's greater performance abilities are complemented for year 2000 with a front chin spoiler, flared rocker panels, a new rear valance, body colored mirrors, polished chrome sport exhaust tip and a sports steering wheel. In addition, the 9-3 SE Convertible integrates a rear bridge spoiler. The SE 5-Door also incorporates a specially tuned sport suspension for more responsive handling.

## All Models

For 2000, the OnStar Telematics system is an option on all Saab models. OnStar supports Saab's 'real-life safety' philosophy by providing extensive security and emergency features through the use of Global Positioning Systems (GPS) and cellular technology. OnStar provides instant accident, theft and navigation assistance - as well as a host of concierge services. Saab is the first European brand to offer this type of system across its entire model line.

All Saab engines for model year 2000 are compliant with Low Emission Vehicle (LEV) standards. Saab 2000 models' warranty features 4-year/50,000-mile "bumper-to-bumper" coverage with 24-hour roadside assistance. Perforation coverage extends for six years with no mileage limit. Saab will continue to perform the first maintenance service free of charge.

*Photos courtesy of Saab Automobile AB.*



### Saab 1999 Sales Continue to be Strong

In the months since our last issue, Saab's sales have continued to show good strength. August, 1999 sales were up by 815 units in 1999 over 1998, or more than 25%. 743 of those units occurred in models which were not available in 1998: the Viggen, and V-6 and station wagon 9<sup>5</sup> models. For September, the increase of 1999 over 1998 was a whopping 74%. In September, 1998, sales dropped compared to August. September 1998 was still an above average month for 1998, although that average includes some dismal months early in 1998. This year sales were more than 600 units greater in September than in August for the third best monthly US sales in history, the best since July, 1986, and the third consecutive 4000+ month.

Sales in September, 1999, were given a boost by a \$3,000 incentive on the lease of a 9<sup>3</sup> sedan along with other \$1000 incentives, such as Saab Owner Loyalty. Sales of the 9<sup>3</sup> sedan, already the most popular single model in Saab's, line were up by almost 50%. In the past we published a treatise on leases, but it takes no calculations at all to realize that a \$4000 incentive on a 3 year lease means more than \$100 off the monthly payment. We asked one dealer the percentage of Saab sales were actually leases, and he told us "at least 70%." The sales of 9<sup>3</sup> sedans did not appear to be at the expense of other Saab models, with the 9<sup>3</sup> SE sedan also showing a major monthly increase, the coupe showing an increase, and the convertible suffering a predictable seasonal decline. The only 9<sup>3</sup> model showing a large percentage decrease in September was the high performance Viggen. Availability may have been a factor in the 9<sup>5</sup> sales volume, as the V-6 models were again in short supply. time

	aug	sep	period
model 900	21	11	32
coupe 9 <sup>3</sup>	68	103	171
Viggen	36	16	52
sedan 9 <sup>3</sup>	1482	2165	3647
sedan 9 <sup>3</sup> se	326	490	816
convertible 9 <sup>3</sup>	465	445	910
convertible 9 <sup>3</sup> se	213	185	398
total 9 <sup>3</sup>	2590	3404	5994
model 9000	12	7	19
model 9 <sup>5</sup>	130	140	270
model 9 <sup>5</sup> v-6 (se)	222	171	393
model 9 <sup>5</sup> se	546	621	1167
wagon	412	260	672
v-6 wagon	73	45	118
total 9 <sup>5</sup>	1383	1237	2620
IDS	38	20	58
total (1999)	4044	4679	8723
last year (1998)	3229	2696	5925
percent increase	25%	74%	47%

### Model Year 2000 Recommended Prices

#### 9<sup>3</sup> Models and Options

3-door		\$25,900
5-door		\$26,400
SE 5-door		\$31,895
Convertible		\$39,450
SE Convertible		\$42,995
3 or 5-door Viggen		\$37,750
Convertible Viggen		\$44,995
Sunroof	Base 3-door, 5-door	\$1,150
Leather Package	Base 3-door, 5-door	\$1,350
Front Heated Seats	All except SE 5-door	\$370
Front and Rear Heated Seats	SE 5-door	\$520
Mica Metallic Paint	All	\$350
OnStar System	All	\$895
Automatic Trans	All, except n/a Viggen,	\$1,200

#### 9<sup>5</sup> Models and Options

2.3 LPT sedan or wagon		\$32,575
3.0 LPT SE sedan or wagon		\$37,750
2.3 HOT Aero sedan		\$39,975
Premium Package (leather seating, Harmon/Kardon Stereo, memory function driver's seat)	2.3 LPT sedan or wagon	\$1,995
Front and Rear Heated Seats	All	\$520
Ventilated Leather	All (Premium package required for 2.3 LPT)	\$950
BBS 17 inch 1-pc Wheel/Tire Pkg.	All LPT (17 inch std. Aero)	\$1,650
BBS 17 inch 2-pc Wheel upgrade	Aero	\$1,950
Mica Metallic Paint	All	\$350
OnStar System	All	\$895
Automatic Trans	All, except std on 3.0 LPT	\$1,200
Transportation Fee	All	\$575



9<sup>5</sup> Aero Sedan shown with optional 2-piece BBS Wheels.

Sales data, Manufacturer's Recommended Prices, and Aero with BBS Wheels photograph were furnished by Saab Cars USA, Inc.



**800-428-8211**  
 LOCAL FAX 206-784-5696  
 OR FAX 800-447-6740

# CARTER

## SAAB

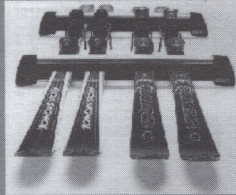

### FACTORY PARTS

OVERNIGHT SHIPPING

20% OFF ALL  
**THULE**  
 ACCESSORIES

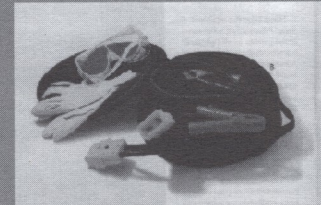

### ACCESSORIES

ALL NEW FREE CATALOG

- STAINLESS TRAVEL MUG.....22.95
- CHILD SWEATSHIRT (S,M,L, JADE OR RASPBERRY).....15.95
- JUMPER CABLE SAFETY KIT.....47.95
- FLAT TOP SKI CARRIER.....104.95

### WINTERIZE EARLY

- FACTORY COOLANT.....6.95

**20% OFF**

- Wiper Blades
- Washer Solvent
- Washer Jets
- Washer Valves

### Call about Saab Winter Tires

Mounted, balanced  
 and ready to go.

### MANAGER'S SPECIALS

- "80-87" 900 FRONT BRAKE PADS.....59.95
- REAR.....39.95
- "88-93" 900 FRONT BRAKE PADS.....40.00
- REAR.....49.95
- 9000 2.3 liter CRANK PULLEY.....112.00
- "80-88" 900 TURBO CLUTCH KITS.....165.95

**LIFETIME WARRANTY  
 ON REPLACEMENT MUFFLERS**



**HOURS 8-5 PACIFIC TIME**  
 MONDAY-FRIDAY

SEE OUR WEB PAGE AT [www.cartervwsaab.com](http://www.cartervwsaab.com)

**CALL NOW TO ORDER 800-428 8211**



On July 20 Saab announced the promotion of Dan Chasins from Executive Vice President and Chief Operating Officer of Saab Cars USA, Inc., to President and Chief Operating Officer. At the 1999 Saab Owners Convention we were privileged to conduct the following interview.

*Saab's Press Release, which described your recent promotion picks up your career at Saab with your position as the 9<sup>5</sup> "Line Executive" in Sweden. Can you expand on that position, and on your background both with Saab and before. For example, had you been an employee of General Motors, as your two predecessors were?*

First off, my only association with GM has been through my employment at Saab. I came to Saab in 1992 as the Director of Marketing. Prior to that I was employed by Alcatel, the French telecommunications company, in their marketing department, and before that I worked for Echlin

Manufacturing. Echlin is an automotive supplier, both OEM and aftermarket. I specifically sought a job at Saab for two reasons. One, I have always been a car enthusiast, and I thought it would be a great challenge to work for a car manufacturer. Two, I had owned a Saab 99, and I thought it was one of the best driving cars I had ever owned.

The position you mentioned, Line Executive, was the last of three which I had while I was over there, and I'll get back to that one in a moment. But the original position I had when I went to Sweden was Program Manager for "New Car Product", which turned out to be the 9<sup>5</sup> wagon. It was a very exciting and challenging position for me, especially since it involved starting the project from scratch. We first assembled a team, then set about the task of developing the product. At the time we started the project, it hadn't been decided whether the companion to the 9<sup>5</sup> sedan would be a wagon or a hatchback. The only requirement was that it would be a variation of the 9<sup>5</sup>.

Once the concept was defined and we'd done the initial development work, the wagon was merged into the 9<sup>5</sup> sedan program to form a unified project. Then, I became the Business Unit Director for the 900 range. At that time, Saab was organized along two separate lines: the business side, and the technical side. My first position in Sweden had been on the technical side in product development, and this new position obviously was on the business side. As the 9<sup>5</sup> was approaching production, the decision was made at Saab to merge these two functions, and reorganize along product lines.

*Isn't this what Chrysler was famous for doing?*

There has been a trend throughout the automobile industry to reorganize into product lines, and Chrysler has executed that

transition marvelously. It provides a lot of benefit to the organization, which the companies now appreciate. It brings both customer awareness and commercial concerns into the technical part of the organization. It also gives the business side, like marketing and purchasing, an appreciation for the technical activity which goes into the design and manufacturing of the product.

Anyway, when the decision was taken to reorganize the 9<sup>5</sup> effort into a product line organization, the position of "Line Executive" was offered to me. I had been planning to return to the US, but took this opportunity instead. The position included the 9000, since its market niche is the same as that of the 9<sup>5</sup>. So I had the twin responsibility of bringing the 9<sup>5</sup> on line and closing down the 9000. It was really quite rewarding for me personally, since I had been in on the original product development for the 9<sup>5</sup> wagon, and now I was responsible for putting it into production. As for the 9000, the original plan had been to continue producing the 9000 for a while. But as soon as the 9<sup>5</sup> was introduced, demand for

the 9000 just about stopped, and we couldn't build 9<sup>5</sup>s fast enough. It was pretty clear that the best thing to do was terminate the 9000 production early and free up that production capacity for the 9<sup>5</sup>.

*You returned as "Executive Vice President and Chief Operating Officer", and now you are "President and Chief Operating Officer", of Saab Cars USA, Inc. Tell me, what is the difference between those two positions?*

Not much. As "President", my official duties include more attention to long range and strategic planning, which I do in conjunction with our Chief Executive Officer, Joel Manby. But in terms of leading the day-to-day operations, it's the same.

*Saab's sales in 1999 have shown a remarkable increase over 1998. In evaluating those numbers, how do you separate out the effects of general prosperity, which leads to higher sales in the premium imported car market, the absence of product in 1998, and the continual broadening of the 9<sup>5</sup> line with the addition of wagons and V-6's?*

We measure our progress in a couple of ways. Absolute sales is one, but we also compare ourselves against our market niche: "Premium European Cars." That includes Volvo, Audi, and much of the BMW and Mercedes line. As compared with this group, our sales growth and market share growth are #1, and many of those marques are also coming in with new products.

*Is Jaguar in there?*

Jaguar is usually considered in a higher market segment: "European Luxury Cars." But with the new smaller entry, they are moving down into our segment somewhat.

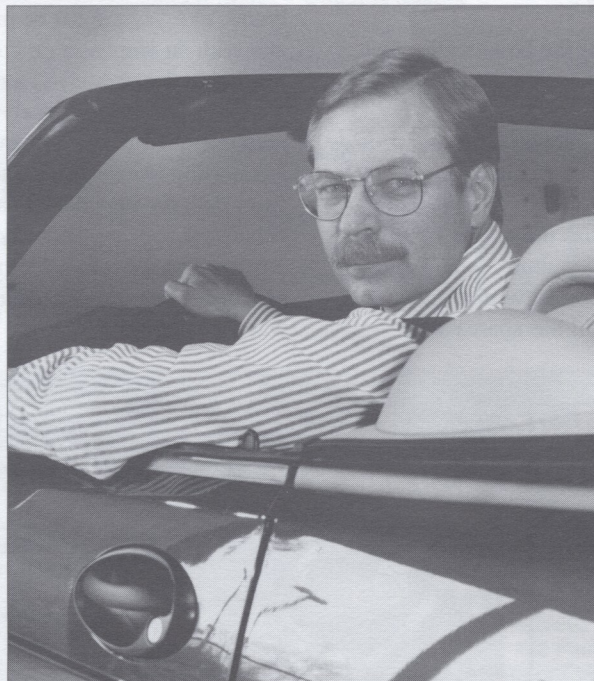

*Photograph Courtesy of Saab Cars USA, inc.*



Speaking of sales, the 9<sup>3</sup> 3-door model sales are pretty weak - in NINES #241 we reported just 161 three door coupes among the 2238 9<sup>3</sup> cars sold in July.

The sales of the coupe have been trending downward ever since the new generation 900 was introduced. It's no mystery, either. The 5-door's styling is just great, and the price difference between the cars is small. So why squeeze through just 2 doors? We have been looking at what we can do to invigorate the coupe. Perhaps it should become the "bargain performance" model: the HOT engine, some nice alloys, and as little else as we can get away with to keep the price as low as possible.

Continuing on with the 9<sup>3</sup>, the current design has been with us for quite a while. Will it be replaced soon, and if so, will it stay a hatchback, or will it follow the European trend of being available in sedan and wagon models - and convertible, of course.

The replacement is under way. As for the body styles, that hasn't been decided yet.

Would you clarify the buy-sell agreement between General Motors and Investor AB?

As is public record, General Motors has the option of purchasing any or all of the 50% share of the joint venture, Saab Automobiles AB, owned by Investor AB at any time between August 1, 1999 and February 1, 2000. If Investor still has shares after

February 1, 2000, it has the option of forcing GM to purchase 25% of the shares of Saab Automobiles during February, 2000. The agreement no doubt specifies a price, or a formula for determining the price, of the transaction, but I am not party to those details.

Do you think either option will be exercised?

Those decisions are up to the Boards of Directors of GM and Investor, and I have no information about how either board might act. However, business magazines and editorial writers have expressed the opinion that Ford's purchase of Volvo's automobile operations has increased the likelihood of GM exercising their option.

What can you say about the changes in the dealer body?

First of all, let me stress the importance of the dealer body for Saab to compete successfully in its market segment. A premium brand, like Saab, must be presented to the buyers with consistency and with an emphasis on customer satisfaction. A strong and profitable dealer body is a necessity for these things to happen. It was tough to make the necessary changes within the existing dealer network. Lexus and Saturn both showed what you can do if you are starting from scratch and with a large financial commitment from both the new dealers and the company. The franchisees' consistent appearance and policies for treating customers were written into the original franchise agreements. Creating that kind of consistency out of our heterogeneous existing dealer network was a challenge.

**SAAB ONLY**

NEW/USED/REBUILT  
**SAAB PARTS**

**DISCOUNT PRICE SPECIALS:**  
(MUST ASK FOR SALE ITEMS!!!!)

Cool folding Cup Holder	\$25
BOSCH fog lens replacement	\$13
900 cloth dash covers	\$29
Haynes 9000 '85-'95 Euro Manual	\$29
Air Mass Meter (005) rebuilt	\$140

Everything Discounted!  
Visa & MasterCard

**800-583-0370**  
in NJ 908-788-7222

**Moncrief Marketing, Inc.**  
Flemington, NJ 08822

**BE HAPPY ON THE WEB**

**LITITZ AUTO SERVICE**

VISIT OUR WEB SITE  
<http://www.saablitzauto.com>



## Interview with Dan Chasins

To achieve our goals, we first set out to ensure that each market area would be of sufficient size and volume potential to make the Saab franchise valuable. Then we sought to have franchises which are owned by dealers who would share our commitment to the standards of customer satisfaction and consistent presentation. In some cases we bought back the franchise and closed the market point down. In other cases we bought back the franchise and sold it to a new operator. And at this point, we believe that the process is pretty well complete. We don't plan to close any more market points, and in some cases we will be adding new dealers. Between the reduction in the total number of dealers and the increase in our sales numbers, we have gone from an average of 67 cars per year per dealer in 1996 to this year being on track to average 195 per dealer. At this level of business we can start to make certain demands on our dealers, since the income potential of being a Saab dealer is definitely there.

*We consistently read rumors in the motoring press about an "All Wheel Drive" future Saab model.*

Saab's corporate position on 4 wheel drive, now commonly called all wheel drive (AWD), has been quite negative. This is something which had been studied in detail, with the conclusion that AWD contributes very little to the mobility and safety of the cars in the manner in which they are used, and that contribution is accomplished at great expense. There is the added cost of manufacture, the reduced interior space, the increased service and repair costs, and the higher cost of operation.

Today that position is being reexamined. With improved technology, the penalties associated with AWD are less. At the same time, the importance in the market for AWD products has increased, especially in the United States - which is Saab's largest single market. As a result, it's fair to say that we've passed the point of deciding "if" Saab will make an AWD vehicle, but rather it's a question of "when" and "how." There is an active and ongoing research program aimed at making an AWD, Saab-like vehicle. By Saab-like, I mean it will be fun to drive, efficient, and it will stand out from the crowd. There's no sense in putting the Saab label on a

lumbering, truck-like 4X4.

*Are there prototypes being driven around at this time?*

No.

*Consider your experience in Sweden. Jim Crumlish came to be President of Saab Cars USA after serving in a staff position in Sweden, Joel Manby came directly from Saturn, and now you have come to be President after serving in several positions in Sweden. How important do you think it is to have spent time in Sweden?*

The time spent in Sweden is definitely a help. I have personal relationships with many of the key individuals at AB, and I have an appreciation for what actually happens over there. But in the final analysis, I think it's the work which I do in my current position which matters the most. Joel Manby, for example, has been given an even greater role in the company, with market responsibility throughout the Western Hemisphere and in Asia, and that was based on what he did here.



# Scanwest Autosport

## Seattle's Foremost Independent Saab Repair Shop



### Winter Specials

**Exclusively for the US Market**

3" Exhaust System from Turbo to Tailpipe made in Sweden for '85-'93 900T One or two muffler \$495.00

#### WE FEATURE

- A Nationwide Mail Order Service • Overnight Shipping
- A Full Line of New & Used Parts • In-house SAAB Transmission Repair

Power Steering Racks	<i>Lifetime Warranty</i>	150.00
Bosch Air Mass Meter-New		325.00
PRB Repco Brake Pads 900 front or rear	per set	35.00
900 Clutch Master Cylinder		70.00
9000 Clutch Master Cylinder		110.00
Bougicord Wire Sets, all models		40.00
ATE Power Disc, 900 & 9000 '88 & newer	each	55.00
AC Idler Bearing w/ Pulley, all	each	20.00
Soft Headlight Protectors		29.95
Antenna Masts, '85 on		18.00
900 Headlight Insert US Spec. '87-'90		85.00
9000 Headlight-Hatchback '86-'90	each	135.00
9000 Headlight-4 Door '89-'92	each	140.00
H-4 Euro Headlights for 900 <i>Off-road use only</i>	each	245.00
<b>Thule Rack Accesories</b>		
Upright Carrier T-599		75.00
Fork Mount Carrier T-589		70.00
Fairing T-555		40.00

All parts carry a 12 month /12,000 mile warranty. If you don't see what you are looking for, give us a call. We stock a full selection of new and used parts for old and new SAABs. If we don't have it, we can probably tell you who does.

888-90-TURBO(908-8726) Or (206) 789-2819 Fax (206) 781-5281

www.scanwestauto.com



9520 Greenwood Ave. N.  
Seattle, WA 98103





## SERVICE INFORMATION

SI No. <b>410-2026</b>	Date <b>August 1999</b>	<b>9000</b>
PI No.	Distr. <b>all</b>	

Cars affected  
Saab 9000 M92- (gearbox no. D41 693-).

### Background

Clutch problems may arise in which the clutch pedal:

- 1 may become hard to depress
- 2 may require more travel before the clutch disengages
- 3 may not be possible to declutch at all

This is caused by the pressure (delivery) hose (marked Dunlop, bumpy surface) emitting plasticizer to the brake fluid. The plasticizer affects all the rubber seals in the clutch system, making them swell. The inner tube of the pressure (delivery) hose may subsequently crack and small particles of rubber collect in the feed holes of the slave cylinder, blocking the flow of fluid.

Leakage of transmission fluid into the clutch hydraulics may also occur, contaminating the clutch system.

The fault should be rectified after customer complaint.

### Parts required:

- 4904 546 Slave cylinder repair kit, Saab 9000 M90- 93 (CA: 30581627)
- 4904561 Slave cylinder repair kit, Saab 9000 M94- (CA: 30581629)
- 49 04 553 Gearbox sealing kit, Saab 9000 M94- (CA: 30581628)
- 4904579 Slave cylinder, Saab 9000 M92-93 (Gearbox no. D41 693-) (CA: 30581630)
- 49 04 587 Slave cylinder, Saab 9000 M94- (CA: 30581631)

Pressure (delivery) hose (dependent on steering wheel position and model year - see EPC for specific model year parts application).

Master cylinder feed (braided) hose (see EPC for specific model year parts application) Procedure

### Important:

**Drain and flush the whole system thoroughly. Clean the fluid reservoir and replace the feed (braided) hose from the reservoir to the master cylinder. Then, replace the master cylinder and pressure (delivery) hose. See EPC for specific part number application. (An alternative for right-hand drive cars is to replace the seals in the master cylinder.)**

1 Remove the slave cylinder, see 4 Clutch system. If replacing the slave cylinder, go to step 13.

2 Press out the locating sleeve and piston from the slave cylinder housing.

3 Pull out the piston from the locating sleeve.

4 Carefully cut away the rubber from the sealing ring in the locating sleeve.

5 Pull out the sealing ring, use special tool (40) 260 147 020.

6 Remove the remaining seals.

7 Wash all components with detergent, especially where sealant has been applied. The surfaces abutting to the gearbox must also be cleaned.

8 Fit new seals on the piston. Lubricate the seals, cylinder and piston with the grease included with ((16) 4904108).

9 Press in a new seal inside the locating sleeve with special tool (16) 78 41 067 and lubricate it.

10 Fit the O-ring on the locating sleeve to seal against the slave cylinder housing.

11 Slide the piston onto the locating sleeve.

12 Put the locating sleeve with piston into the slave cylinder housing, making sure it is fully seated.

13 Clean the surfaces on the slave cylinder to which sealant is to be applied.

Clean also the corresponding surfaces on the gearbox.

Important - Steps 13-17 must be carried out each time a slave cylinder is fitted.

14 Apply liquid sealant Loctite 638. Allow the sealant to spread for a minute or so.

15 Fit the green seal onto the rear of the slave cylinder, use Loctite 638 to keep the seal in place while fitting.

16 Lubricate the clutch plate seal with transmission fluid.

17 Fit the slave cylinder:

Apply threadlock (16) 74 96 284 to the bolts.

Tighten torque: 10 Nm (7.4 lbf ft)  
Fit and tighten the delivery pipe and bleed nipple.

Fit the release bearing.

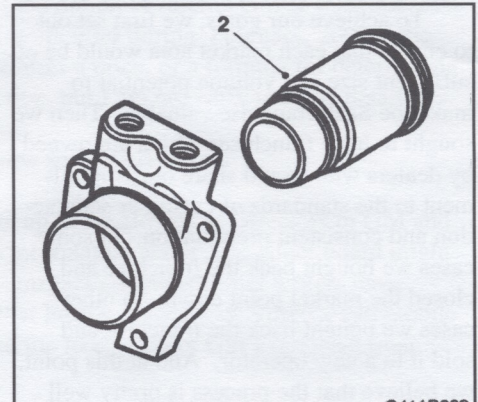

C411B602

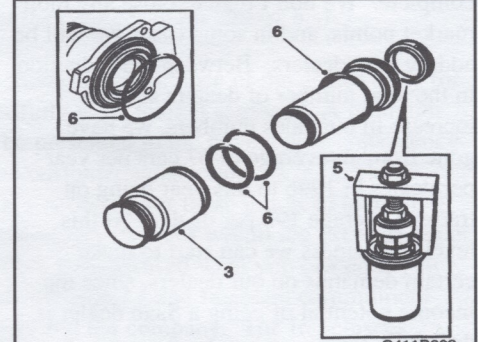

C411B603

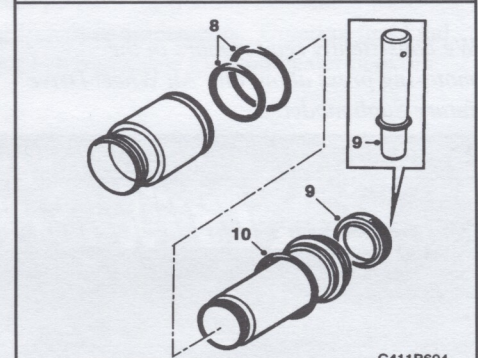

C411B604

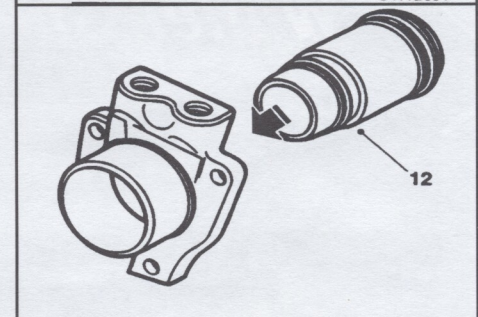

C411B605

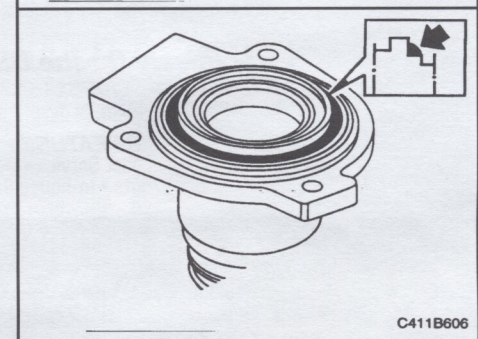

C411B606

Saab Automobile AB Bulletins are intended for use by professional Saab technicians only, NOT a "do-it-yourselfer". They are designed to inform these technicians of conditions that may occur on some vehicles, or to provide information that could assist in the proper service of a vehicle. Saab trained technicians have the equipment, tools, safety instructions and know-how to do a job properly and safely. If a condition is described, DO NOT assume that the bulletin applies to your vehicle, or that your vehicle will have the condition. See your authorized Saab Dealer for information on whether your vehicle may benefit from the information.  
© 1998 Saab Automobile AB All rights reserved



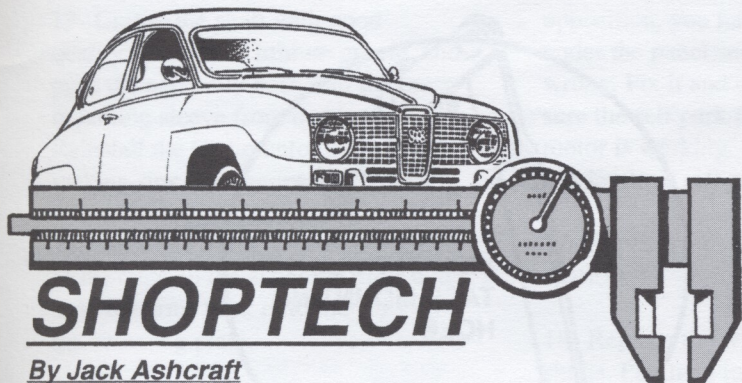

# SHOPTECH

By Jack Ashcraft

## REPAIR OF SAAB 95/96 WIPER BLADE PIVOTS

One of the indicators of high mileage on these cars is wiper blades that have a lot of slop in them, or in extreme cases, actually beat against each other. The cause is usually the primary wiper pivot shaft "working" in its actuating plate. Saab only riveted the two together, welding apparently was not deemed necessary. Here is how to cure the problem:

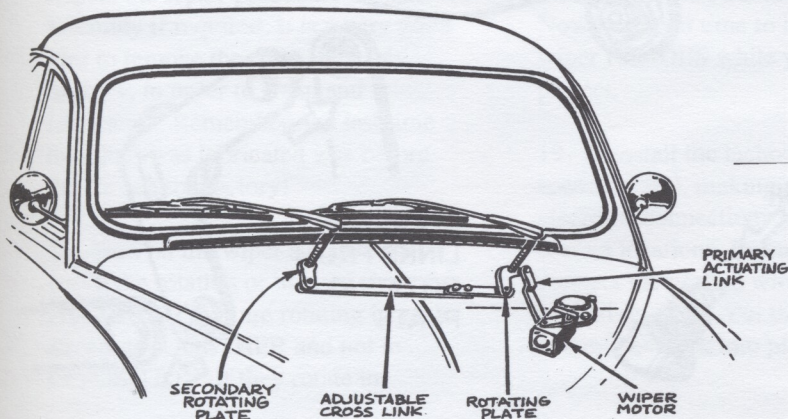

SAAB 96 WINDSHIELD WIPER SYSTEM

### REMOVING THE WIPER ARM

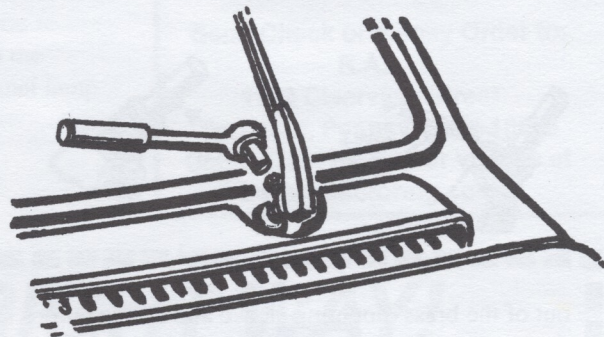

1--Remove both wiper blades, using an 8mm socket. Loosen the mounting bolt, and lift off the wiper blade assemblies. Take care not to let the ratchet handle hit the windshield glass!

2--Inside the car, remove the tachometer (850GT, Monte Carlo and Deluxe cars) or the speedometer (standard cars). These instruments are held in place with two retaining clamps and nuts (tachometer) or one big clamp held in place by one big center nut (speedometer). Note that there is a black ground wire held in place by the left retaining nut (tachometer). On speedometer only cars, this is a push on connector on the big clamp. Tachometers have one panel illumination light, at the top of the instrument, speedometers have two, one on each side. Pull the lamp and socket free of the instrument and let it hang. Tachometers also have three electrical push on connectors (see drawing). Pull these loose, noting their colors and locations. Speedometers have an additional lamp socket at the bottom of the unit, for brake pedal excess travel warning. Lift the tach (or speedo) out of the panel.

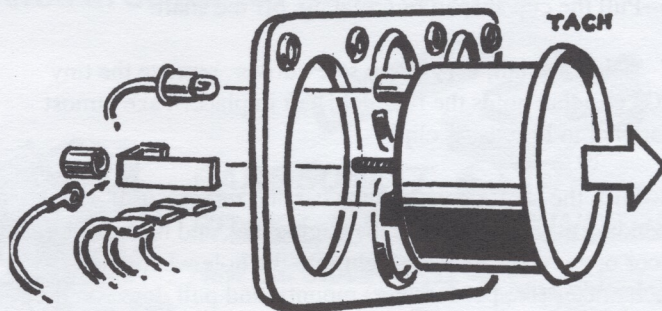

REMOVING THE TACHOMETER

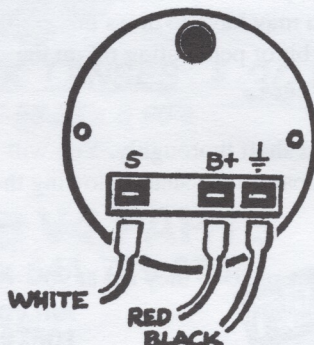

WIRING FOR THE TACHOMETER



3--Put your trouble lamp up under the instrument panel. It is a GOOD idea to use a florescent type trouble lamp so the heat from an incandescent trouble lamp does not melt anything under there. Look thru the hole where the instrument was. The drawing shows the wiper linkage you will see.

4--Use a suitable screwdriver and pop the two actuating links off the rotating actuating plate.

5--Outside the car, check the shaft where the wiper arm mounts. It probably will be indented and otherwise damaged. Use a small file to make it round. You must push it down,

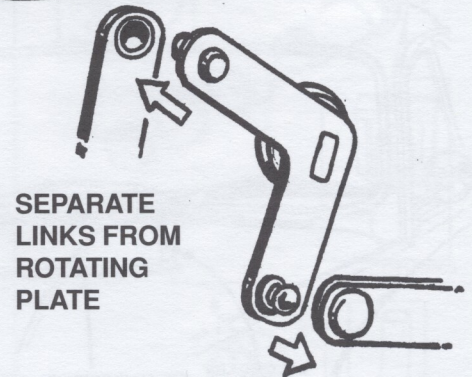
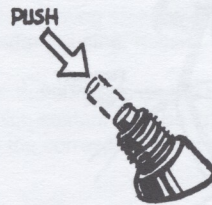
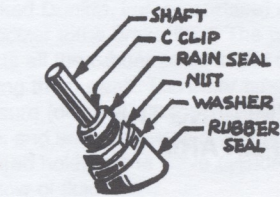
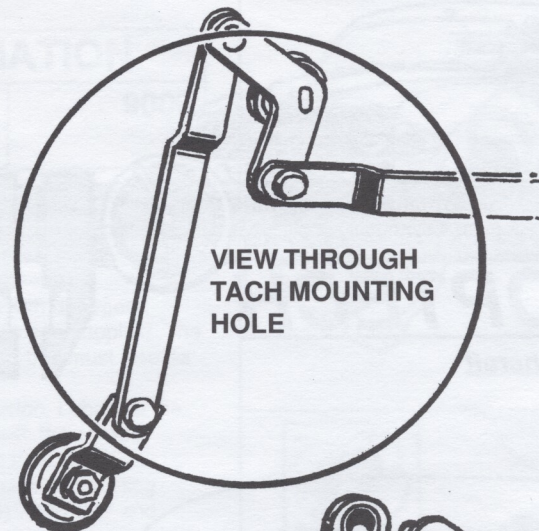

out of the brass mounting sleeve and all the bumps and other damage must be removed so it will push out.

6--Pull the cup shaped rain seal up, off the shaft.

7--Using a small, very sharp screwdriver, remove the tiny "C" clip that holds the rotating shaft in place. Take utmost care not to lose the C clip!

8--Push the shaft down into the car and remove it. If you are standing at the left side of the engine bay, and have the left door open, you can reach right into the hole where the tachometer (or speedometer) mounts, and pull down on the shaft/actuator plate ass'y as you push from the outside. If it does not want to come out, you may have to dress the shaft a bit more with your file. Also a bit of penetrating oil on the shaft certainly won't hurt anything.

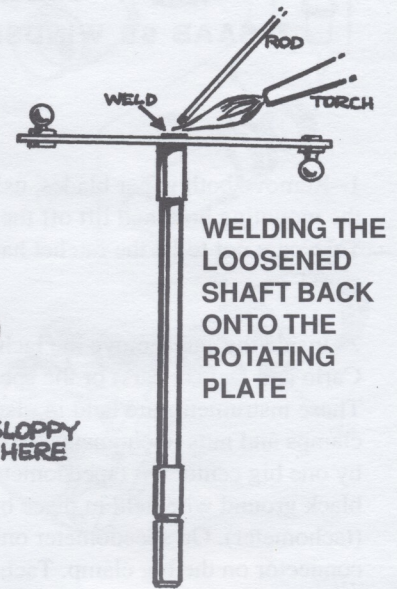
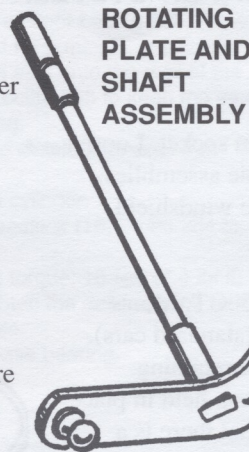

9--Clean the actuating plate and shaft thoroughly. You will see that the actuating plate is loose on the shaft, allowing the wiper slop.

10--Situate the shaft and actuator plate so they are at 90 degrees to each other, in both planes.

11--Weld the shaft and plate together, from the side AWAY from the shaft ONLY (see drawing). Allow to cool.

12--Paint the actuating plate with a high zinc content paint to inhibit rust formation. We use paint made by PPG, No. DPE 1538, and apply it with a brush. It is acrylic enamel and requires lacquer thinner to clean the brush. Allow the paint to dry thoroughly.



13--Grease the shaft with good quality waterproof lithium grease, and push the assembly back into the brass mounting sleeve from inside the car. Reinstall the C clip onto the shaft, making sure it snaps into its groove.

14--Put a dab of the grease into each of the cups on the actuating arms and snap the arms back onto the balls on the actuating plate.

15--Check the slop (if any) in the RIGHT side shaft and actuating plate. Repeat the repair procedure on that assembly if required. It is a very good idea to remove the right assembly anyhow, in order to clean and lubricate it. Remember, the last time that shaft was lubricated was before the car left the factory!

16--Turn on the wiper switch and watch the rotation of the two shafts. Make SURE they are rotating in each direction TOGETHER and not in OPPOSITION. If they rotate in

opposition, you have the linkage under the panel snapped together wrong. Fix it and check again. Make sure the self park feature of the wiper motor is working. Turn off the wipers and let them self park.

17--Replace the rain seal cups on the shaft(s).

18--Replace the wiper blades onto the shafts. Put them in their correct park positions and tighten the retaining bolts. Turn on the wipers and check their operation. Readjust as necessary. Now is a good time to install new wiper BLADES while you are at this project.

19--Reinstall the tachometer (or speedometer), making sure all the electrical connections go back in their correct locations. Be sure you re-connect the ground wire on the mounting clamp. Put the panel lamp assemblies back into place.

**R.A. MOTORING**  
**The Saab Kiosk**

**Front Plates - U.S. Size**  
Swedish - \$27. Black "Saab" logo on chrome or chrome on black - \$25 Stainless steel background - \$27

**Euro-Plates - Choose from Swedish or customized - \$35**

**Air Valve Caps - The ultimate wheel detail - Griffin Logo on Graphite, Aluminum or Chrome - \$20. Matching Key Fob/Wrench - \$20 or \$35 for set**

**Saab Parking Only Signs - Aluminum Red on white - \$25**

—●●●— - Airplane Decal  
Approximately 1 1/2 x 5 White - \$5  
**Griffin Decals - W/Saab Aero Space Full color 4" in diameter - \$11**

**Send Check or Money Order to:**  
**R.A.**  
1723 Clearview Street  
Scranton, Pennsylvania 18508  
Call 1-888-411-2205 or visit us at  
[www.ramotoring.com](http://www.ramotoring.com)

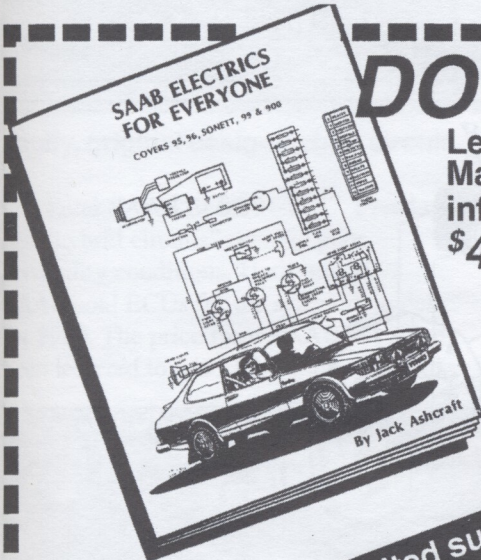

**DO IT THE RIGHT WAY!**

Learn all about your V4 electrical system!  
Major circuits covered in detail. 100 pages of great information!  
**\$45.00 plus \$5 S&H**

**Only 2 left!**

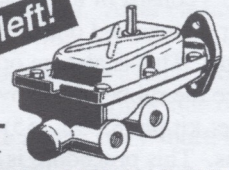

**RARE SONETT**  
**BRAKE MASTER CYLINDERS**

New old stock **\$349.00** plus shipping  
They won't last long at this price!

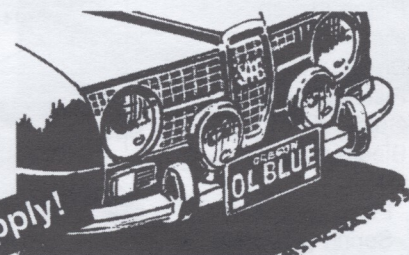

**Limited supply!**

**FRONT TURN/PARK LENSES \$ 39.00 each plus shipping**  
New old stock, fits 1965-68 95's & 96's

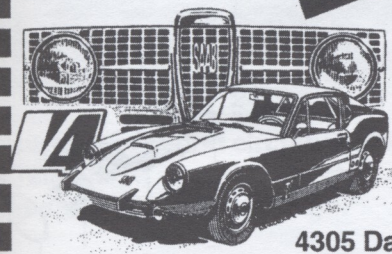

Jack Ashcraft's  
**ORPHAN SAAB V4 PARTS**

Ph 541-779-0731 Fax 541-779-0788  
email: [jackashcraft@prodigy.net](mailto:jackashcraft@prodigy.net)  
4305 Dark Hollow Rd, Medford OR 97501

**FREE CATALOG!**



### Cheap Fix for 99/900 Calipers

"It seems like the parking brake doesn't work anymore, and the calipers are sticking." Eventually, most Saab 99 and 900 owners face this problem. Those who drive 99s built from 1975-on, or 900s through 1987 have probably already experienced it. The handbrake operates on the front calipers on these Saabs, making them a bit more complicated than calipers on other cars.

The brakes start smoking at an intersection, and the car pulls to the opposite side under braking. The parking brake only comes up one or two notches instead of the factory recommended 7 to 9 notches. Sounds like a stuck caliper, right? The mechanic has probably suggested the only solution is to replace the calipers at over \$100 apiece. Maybe, but not always. The more common problem is that the parking brake lever in the caliper has become corroded and is binding. It can be repaired in under an hour for less than \$20.00. And you won't have to remove the calipers from the car or bleed the brakes.

Though the seal kits (p/n 89-93-727, Saab retail, \$7.50) can be purchased for each caliper, Saab does not sell the parking brake lever as a separate part, so if the shaft on the lever is badly pitted you will have to replace the entire caliper. That's why it's necessary to do this procedure at the first sign of trouble. The seal kits consist of three pieces, two rubber o-rings and one aluminum retaining ring. This is also an opportunity to replace the rubber dust covers and seals (caliper kit p/n 89-93-255) on the caliper pistons. This procedure is not in any Saab manual that I have seen. You may wish to copy this page and insert it into your 99 or 900 repair manual for future reference.

1. Raise front end off ground with a jack. Lower car onto jack stands. Remove front wheel(s).
2. Turn brake assembly for best access to front of caliper. It is not necessary to remove the caliper from the car.
3. Remove brake cable end from parking brake lever.
4. Remove return spring for parking brake lever.
5. Remove brake pads (see manual).

6. Slide the caliper in the yoke until the slot in the indirect piston can be displaced in the yoke enough to remove the parking brake lever from the indirect piston. You may have to back the direct piston into indirect piston using the Saab caliper piston tool 89-96-043.
7. Pry out the retainer and two o-rings from the hole in the back of the indirect piston with a screwdriver. Remove any rust or dirt that may damage the new seals.

8. Install the new o-ring seals. The thicker o-ring goes in first, and the thinner o-ring fits inside the aluminum retainer. Lubricate the new seals with Syl-Glide or other rubber lubricant.
9. Clean the rust off the parking brake lever shaft on a wire wheel or with emery cloth. Lubricate the shaft with Syl-Glide before installing into the indirect piston.
10. Make sure the parking brake cable moves freely in its housing before re-assembly.
11. Reassemble in reverse order.
12. Return the calipers to normal operating position by following the instructions in the manual.

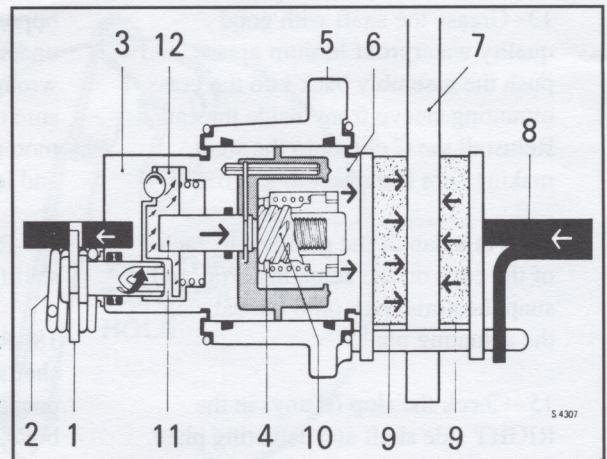

Adjustment Device, Handbrake Mechanism

1. Handbrake lever
2. Return spring
3. Brake piston (indirect)
4. Drive ring
5. Brake cylinder housing
6. Brake piston (direct)
7. Brake disc
8. Yoke
9. Brake pad
10. Sleeve
11. Push rod
12. Thrust plate

-Tim Winker

Front Brake Housing, Exploded View

1. Dust cover holder
2. Dust cover
3. Piston (direct)
4. Push rod
5. Brake housing
6. Piston seal
7. Guide clip
8. Bleeder nipple
9. O-ring
10. Piston (indirect)
11. Spring (left-green, right-red)
12. Spring (handbrake lever)
13. Handbrake lever
14. Yoke
15. Pad retaining pin
16. Lock clip
17. Brake pads
18. Spring
19. Damper spring
20. Retainer (two o-rings)

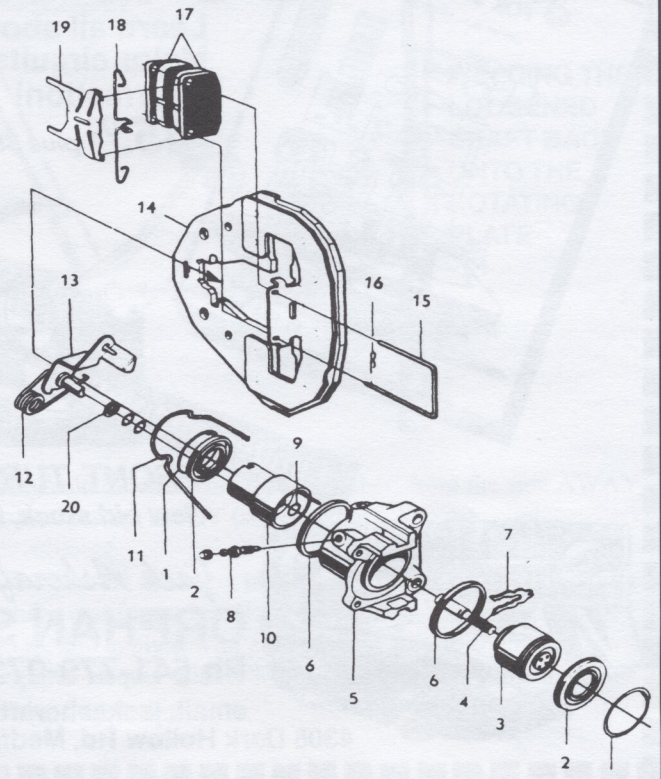



**ECU Failures in SAABs with LH 2.4 Fuel Injection.**

Over the past 12 years as a Saab specialist, I have seen an inordinate number of Engine Control Unit (ECU) failures in 1988 through 1990 900s.

The first failures noticed outside of the dealer network were generally related to the failure of the ECU to ground the fuel pump relay. I developed a work-around for this problem using the 8 valve fuel pump relay so loss of ignition signal (ie after a crash) would cause the fuel pump to turn off. My brother Gerry determined that the 40pin "hybrid" circuit on the ECU board was at fault in the fuel pump relay issue. I soon found additional failure modes where the vehicles ran extremely rich sometimes keeping the injectors open 100% of the time. Could the "hybrid" circuit be causing this also?

\$960.00, an incredible profit margin would be possible if the unit could be "rebuilt". A cottage industry of rebuilders sprang up. (SAAB was not the only manufacturer using LH 2.4.) A "bogus rebuilt" unit shown is the ugly side of the

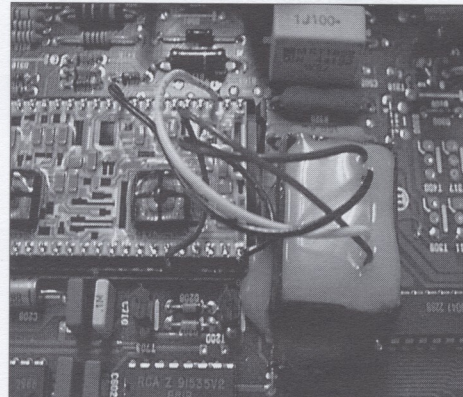

**Bogus "rebuilt" ECU. Note module wired to faulty original design.**

Note the layout of the chip capacitors in the upper left of the hybrid. The differences in layout will help you identify the good and bad units. I have seen few failures of 9000s with LH 2.4 so far, but it could happen.

The easiest way to determine if you have an LH 2.4 system is to check the connector for the idle air control valve. If it has 2 wire connections, you have an LH 2.4 system.

I hope this article illuminates the problem of ECU failure.

*By John Schreiber  
John and his brother Gerry own and operate SAAB Service shops in Ft. Lauderdale and West Palm Beach, Florida. Both are ASE Certified Master Technicians and ASIA World Class Techs.*

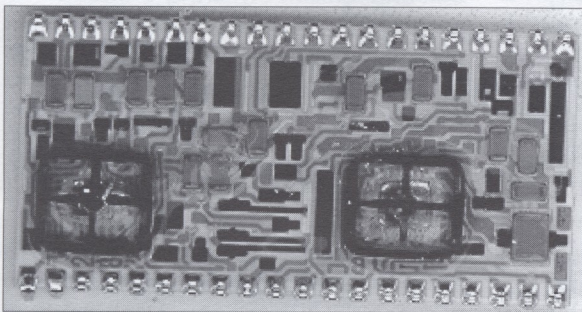

**Faulty, original design hybrid circuit.**

Enter SAAB SI 03/91-0097. I read of bad "hybrid circuits" causing poor drivability conditions. Until mid 1998 SAAB sold ECUs for the affected models for \$960. The price from SAAB has since been lowered to \$491.00. With a price of

business. It lasted only about 16 months. You can see the homemade circuit soldered on to the bad hybrid circuit. Used units while cheaper initially, are only a temporary fix. A properly repaired ECU would have the later design hybrid circuit soldered on by someone

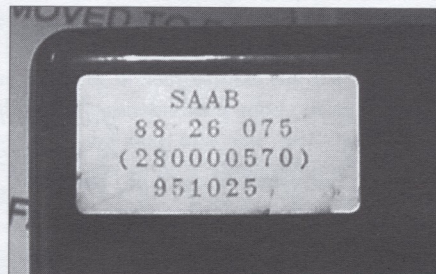

**Crude paper label identifying bogus rebuilt ECU.**

skilled in the art.

The defective hybrid circuit is Bosch 0273002126. In my opinion all of these will fail sooner or later. I was able to buy new replacement hybrid circuits Bosch number 0273002132, until the first of this year when Bosch said NO MORE! (I believe they were losing sales to outside rebuilders, which is ironic

when the failure appears to be of their own design.)

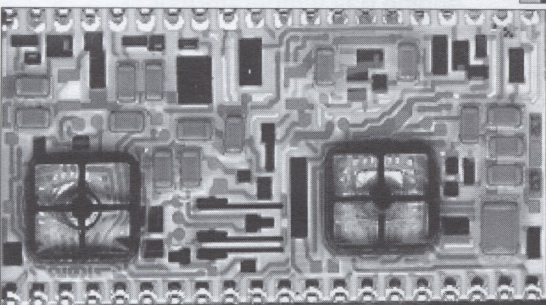

**New design hybrid circuit. Note different arrangement of components to distinguish old design from new design.**

**9000 2.3L Oil Leak**

I started noticing oil dripping from the right bottom side of my wife's 1991 9000 2.3L with 168,000 miles last month. Upon inspection, the whole right underside of the car was wet with oil and it seemed to be leaking from the bottom right front of the engine around the crank pulley. Figuring the crankshaft seal had worn out, I pulled the crankshaft pulley and installed a new seal. After cleaning off all oil dripping from various parts of the car, I test drove it only to find more oil dripping from the bottom right side of the engine. To make a long story short, the oil pump cover is right behind the crankshaft pulley and is sealed to the engine block with an eight inch diameter "O" ring. Over the years, this "O" ring takes a set and actually becomes brittle. So I again removed the crankshaft pulley and then removed the aluminum oil pump cover and replaced the "O" ring. The old "O" ring actual broke into two pieces upon removal it was so brittle! Place some newspapers or a pan underneath when removing the oil pump cover, as you will lose about a half cup of oil, which I assume is the residual left in the pump and oil ducts. You also need to first remove the crank pulley optical sensor before you



*Dear Dr. Nio:*

Here are two for Dr. Nio, both having to do with my 1974 Sonett III, S/N 2020:

1.) In hot weather, the engine stalls on rapid acceleration from a stop as if it has a vapor lock. It doesn't quit entirely, and letting off the throttle and waiting a few seconds will allow the engine to revive. Only gradual acceleration will ensue thereafter until the car is up to speed. I have an electric fuel pump,

mounted on the forward left frame, feeding a Weber 34 ICH through a Purolator fuel pressure regulator set to the 3.5 psi limit of the Weber. I've increased the fuel line diameter from the pump to the carburetor to 5/16" from the original 1/4" and routed the line to make sure it passes behind the fan. I've also insulated the fuel line by passing it through sections of heater hose where able. I'm using a Fram G-6 filter positioned between the regulator and the carb. I've also tried motoring about with the hood cover off to see if there is a change in symptoms, but no. When the A/C is in use, the problem is of course worse. Any suggestions?

2.) Using multiple electrical consumers at once will deplete the electric power available to the point at which the horns won't blow, especially when using the A/C and lights together. I've installed a Bosch-rebuilt 70-amp alternator with built-in regulator and a larger capacity battery. I've also replaced the battery ground and added an extra ground strap from the engine to the frame. The voltmeter will drop from the nominal 12-14 v. to 8-10 when hitting the horns (the originals or new ones I've installed) without a sound, or maybe with a weak bleat. The horns work fine when not using other major consumers. Is there a common consumer ground that I'm missing that might be corroded? What else?

John Betsill  
Acworth GA

The two problems could really be only one. We only have partial information, but the big clue here is the immediate voltage drop when any

serious electrical USER is engaged. We don't know whether or not the "larger capacity battery" is a brand new one. The symptoms suggest a battery with a dead cell. It will read 12-14 volts and the alternator will keep it at that level, but as soon as a serious load is applied the surface charge on the battery goes away and the voltmeter drops and nothing works—horns, for example, and probably the electric fuel pump. I would put in a NEW battery and try it all again.

Next, the GROUND wire connection to the frame in the trunk next to the battery must be clean and free of corrosion. Then check primary positive path. Current flows via the heavy red wire from the battery to the starter. Next in the chain are the wires that go from the same starter terminal to (A) the alternator, and (B) the fuse box and ignition switch. Old Saabs' wiring often have been altered by well meaning wrenches who had no clue as to wire diameters or factory wire routing. The wiring in the car must be compared to the service manual wiring diagram and corrections made where necessary.

John doesn't say where on the left front frame he located the electric fuel pump, but if it is still anywhere inside the engine bay it is far too hot for an electric fuel pump, and air conditioning makes it even hotter. It must be mounted inside the so-called Swiss cheese panel behind the seats. There is adequate room to mount the pump, regulator and a fuel filter in that location, which stays cool (relative to engine bay temperatures).

*Oil Pump Seal Continued....*

can remove the pump cover. I suggest you use blue Loctite on the screw threads when reinstalling them to make sure they don't work lose. Also, check the crankshaft pulley, as noted in a previous Nines article, to make sure the pulley is not separating.

Richard Bohn  
Hollis, N.H.

*As noted in Chuck Andrews' "Professional Perspective", one should also not the condition of the "woodruff key" which locks both the oil pump and the crankshaft pulley to the crank whenever working in the vicinity of the crank pulley. - ed.*



**Exclusively SAAB**  
Since 1969

**Rust Free Used Parts**  
There is NO RUST in Colorado  
125 SAAB'S TO PICK FROM

**1-800-757-7222**

519 Lipan St - Denver, Colorado 80204-4906  
Phone (303)595-4646 - FAX (303)595-0124  
www.milehibodyshop.com



**TROLLHATTAN AUTO PARTS INC.**  
SPECIALIZING IN PARTS FOR SAAB & VOLVO

OEM, OE & AFTERMARKET PARTS AVAILABLE  
PARTS DISCOUNTS UP TO 50% OFF LIST PRICE  
CALL FOR MONTHLY SPECIALS

**SAAB 1800-32TROLL VOLVO**  
<http://www.cybertroll.com> 410-682-2827

MOST ORDERS SHIPPED WITHIN 24 HOURS / VISA, MASTERCARD & AMERICAN EXPRESS ACCEPTED



Performance Sells! And any car company that wants a performance image needs to have a race team to back up that image. Saab does not, and I believe their sales suffer as a result. Take a look at the companies Saab considers its main competition: Audi, Volvo, BMW, Mercedes-Benz, and the higher-priced Volkswagens. All have race teams of some sort, many in the top ranks of motorsport. This year at The 24 Hours of LeMans, there were multi-car teams from Audi, BMW, Porsche, and Mercedes-Benz. All of these were specially-built, single purpose racers, not production line machines converted to racing use. The budgets for this single race are huge!

Mercedes is also heavily involved in Formula 1 and CART ChampCar racing, providing engines that power the front running cars in both series. BMW is active in many racing series, especially sports racers for the Professional Sports Car and USRRC series, which are essentially LeMans style sports racers. They have also been heavily involved in backing teams for several levels of sedan racing in the U.S. Volvo is a front runner in the British and Australian Touring Car Championships with the S40, a smaller model which has recently been introduced to the U.S. market. (BTCC and ATCC races are regular features on Speedvision and Fox Sports channels.)

Which brings us back to Saab. They have one factory-backed car that I know of - Per Eklund's Rallycross 9-3. While it looks like a 9-3, the resemblance is about as much as a drag racing funny car. The engine is all Saab, but the drivetrain is an X-Trac 4-wheel drive system. The engine is rated above 600 HP, but, like in drag racing, only has to last a short time as rallycross heats generally are less than one minute apiece. (A European Rallycross consists of driving on a purpose-built road course with both paved and gravel surfaces. A heat usually includes five or six cars, from which the bottom half is eliminated.)

If Saab really wants to compete against the likes of BMW and Audi, they need to put more marketing funds into motor sports. Motorsports sponsorship is considerably less expensive than regular advertising, often on a scale of 1/10th the cost. As the major motorsports such as NASCAR Winston Cup and FedEx CART ChampCar have grown, there has been a growing interest in other forms of mechanized competition as well, from potential competitors as well as fans. Those who have followed my scribbles for the past 14 years are aware of my interest in performance rallying, represented in the U.S. by the SCCA ProRally series. Saab Cars USA

did sponsor a Saab team a couple of years ago and was rewarded with considerable press coverage, despite the fact that the car did not finish most of the events entered the first season. Team Saab (Sam Bryan and Rob Walden) did go on to win the 1997 Group 5 Driver and Co-driver titles, but the Manufacturers' Trophy went to Toyota, mainly because there were more Toyotas competing in the series and they were more likely to pick up points. Occasional backing of another Saab or two could have put that award in Saab's trophy case. While I am not privy to the exact figure, close sources indicate the team received between \$100,000 and \$150,000 from Saab Cars USA to fund the 1997 season. The Saab PR department also provided backing in the form of press releases and posters, maybe doubling the actual racing budget for the year. The Saab USA advertising budget for that year was around \$50 million. By comparison the funding of the rally team seems like pocket change. While I would certainly like to see Saab back in ProRally in the U.S., and they would certainly be competitive, I seriously doubt Saab could compete in the World Rally Championship against the likes of Subaru, Mitsubishi, Ford (of Europe) and Toyota. However, I can see no logical reason for the folks in Trollhattan to avoid putting cars into the British or German Touring Car series, the various national European rally series, or other European races, where Win On Sunday does translate to Sell On Monday.

A strong revival of the racing contingency program once offered by Saab Cars USA would be a good start to promoting the use of Saabs in competition. Subaru's U.S. sales office announced a good contingency program beginning this year, and I have been amazed at the number of rallyists and racers who have already bought Subarus for competition just for the chance to win a few bucks. In addition, there are many fans of motorsport who buy cars like those they see in competition. There are considerably more Subarus among the workers and spectators at ProRallies this year than I have ever seen, especially the boy-racer RS sedans and not the Outbacks that you see in the TV commercials. Coincidence? I don't think so.

After Saab posted dozens of speed records during the 1996 Saab 900 Talladega Challenge, they said they would be back when the new model came out. That new model is the 9<sup>5</sup> and I expect that it will visit the high-banked oval track at Talladega later this year. While the event will be heavily promoted in Europe and other markets, the U.S. marketing group will probably add it as a minor footnote in an ad or two, just like last

time. The public relations departments in Sweden and the U.S. put a lot of effort into the Talladega record runs in 1986 and 1996, but the U.S. marketing department didn't follow through on promoting the performance image that the PR folks worked so hard to nourish.

The 900 Talladega Challenge got good coverage on the editorial pages of auto magazines, because automotive journalists were invited to be among the drivers during the record runs. Saab will have to come up with some clever PR to top that for the 9<sup>5</sup> challenge. That solitary event, however, is not enough to foster the performance image that Saab needs to sell cars. Diversity is the key, especially since Saabs are promoted as cars that do many things well. Promotion through a strong contingency program is a good start, but a few well placed, factory backed race teams would show that Saab's performance image is deserved, and not just some fancy body kits and decals.

I've been culling the Saab herd at Viggen's Valhalla Vista on Bear Trap Junction. Saab Sonett #000069 has moved to Seattle where Eric Lotsfelt has promised to take good care of it, better than I have been able to manage over the five years of my ownership. In that time I drove the little stroker sports car only a few times, never very far from home, and did not put the effort into making a few little repairs and adjustments to make it more reliable. And since I am short of leg and long of torso, my head would brush the ceiling. It was not comfortable for me to drive on longer trips nor on vintage rallies (a primary reason I bought it in the first place). Eric is a better fit and seems to have the enthusiasm to restore that car into what it should be.

Another Saab leaving the stable is one of the Blonde Swedish Twins, known as the "Second Banana". It was the second Alabaster Yellow 1979 99GL that I bought, the one that was converted into an Improved Touring race car and later modified for Pro Rally use. Spending time on competing and keeping this car up and running was taking too much time from other potential project cars in the barns. Though it is still here as I write, a buyer from Texas says he will be here later this week to make it his.

The first major project from my effort to join the league of Internet publishers is up and running. Check out The Speedtrap Exchange, [www.speedtrap.org](http://www.speedtrap.org). The Saab Club web site ([saabclub.com](http://saabclub.com)) is next. I have also established web sites at [winktimber.com](http://winktimber.com), [winker.net](http://winker.net) (family stuff) and [arrowheadscc.org](http://arrowheadscc.org).



# North American Saab Clubs and Contacts

## NEW JERSEY SAAB OWNER'S CLUB GETS NEW LEADER, AND A BIG JOB!

Leadership of The New Jersey Saab Owners has been transferred from Bob Adams to Larry West of North Plainfield, New Jersey. Larry has been a Saab owner since 1983, when he bought his first Saab, a 1976 99 GL. More recently, Larry has organized two tours of New Jersey, New York and Pennsylvania roads, organized last November's very successful technical session with John Moss of Saab Cars USA. He has been a member of the national planning committee for the last two national conventions. This should serve him in good stead since the New Jersey club will be co-hosting the 2000 convention with the New England Sonett Club. If you are interested in the club, phone Larry at 908-507-6691, or go to <http://www.saabturbo.com/njsoc>.

## CENTRAL STATES SAAB CLUB, LINCOLN, NEBRASKA

Central States SAAB Club was founded this past summer and has published its first newsletter. The main purpose in founding the club is to increase awareness to Saab lovers in the area. They welcome anyone, but are based mostly in Nebraska and Iowa, and surrounding states.

## THE HUDSON VALLEY GETS A SAAB OWNERS' CLUB

The SAAB Club of New York is being founded with the support of Roberti Motors. They are located in Kingston, about half way between Albany and New York City.

## NORTHEASTERN OHIO

We are organizing an Owners' Club in NINES' home turf. Please contact Stephen Goldberger, the Editor of NINES, or Jim Levine at Ed Wolf Shaker SAAB, (216) 231-7222 for details.

## North American Saab Clubs & Contacts

### Appalachian SAAB Club

Ken Edwards  
296 Brethren Church Rd.  
Jonesboro TN 37659-  
423-753-3153

### Bay Area SAAB Club (Northern California)

Douglas Morse  
25291 Morse Ct.  
Hayward CA 94542-  
510-582-1858  
Email:saab\_club@prodigy.com

### Carolinas Saab Register

Jason Henske  
2830 16th St. NE Apt. #99  
Hickory NC 28601-  
704-256-9211  
Email:NCSaabreg@AOL.com

### Central Penn SAAB Club

George Basehore  
477 E. Main St.  
Middletown PA 17057-  
717-944-2915

### Central States SAAB Club

c/o Kyle J. Poppert  
4015 N Street  
Lincoln, NE 68510  
402-488-5730  
saabarts@aol.com

### Delaware Valley SAAB Club

Pat Bolmeyer  
1311 Clifford Rd., Oak Hill  
Wilmington DE 19805-  
302-994-2173

### Gateway City Saab Club

Greg Cassidy  
62 E. Adams Dr.  
Cahokia IL 62206-  
(618) 320-5330

### Great Lakes SAAB Club

Jim Laman  
617 Beechwood  
Holland MI 49423-  
616-335-5215  
Email:lamanjim@juno.com

### Green Mountain SAAB Club (Vermont)

Cathleen Pembroke  
RFD #5, Box 2758  
Montpelier VT 05602-8812  
802-476-7994  
Email:sbprods@earthlink.net

### Gulf Coast SAAB Club

Ron Hernandez  
2422 Killdeer St.  
New Orleans LA 70122-4316  
504-283-0822  
Email:rthrnandz@AOL.com

### Milwaukee SAAB Club

Andy Saksa  
2480 Eastwood Ln.  
Brookfield WI 53005-  
414-785-1550

### Minnesota SAAB Club

Dean Nelson  
1420 15 Terrace NW  
New Brighton MN 55112-  
612-636-3771

### New England Sonett Club

P.O. Box 4362  
Manchester NH 03108-  
Email:sbprods@earthlink.com

### New Jersey Saab Club

Larry West, Chairman  
465 Tappan Avenue  
West Plainfield, NJ 07063-1823  
908-507-6691  
njsoc@pobox.com

### Northwest SAAB Owners (Washington, Oregon, British Columbia)

Skip Schott  
20220 80th Ave. SE  
Snohomish WA 98290-  
425-486-1351

### Rocky Mountain SAAB Club

Jerry Danner  
519 Lipan St.  
Denver CO 80204-  
303-595-4646

### SAAB Club National Capital Area

Donald Titus  
3504 Hutch Place  
Chevy Chase MD 20815-  
301-652-6806

### SAAB Club of Central Ohio

Dan Orzano  
2434 Dover Rd.  
Columbus OH 43209-  
614-231-3892  
Email:dorzano@compuserve.com

### SAAB Club of Georgia

Chris McPherson  
915 Franklin Goldmine Rd.  
Cumming GA30040-  
770-844-5961

### SAAB Club of Iowa

James Iverson  
P.O. Box 2329  
Cedar Rapids IA 52406-2329  
319-364-4015



**Saab Club of New York**

Laura Delehanty  
Foxhall Avenue  
Kingston, NY 12401  
914-339-7222

**SAAB Club of NE Pennsylvania**

Ron Augelli  
1723 Clearview St.  
Scranton PA 18508-  
717-969-9863

**SAAB Club of Texas**

Craig Bobchin is no longer a resident of Texas, and we have not received information of a replacement. Please contact NINES if you know!

**Saab Owners of Canada, Inc.**

John Casey, Pres.  
4214 Dundas St. West Suite 106  
Toronto, Ontario  
Canada  
M8X 1Y6  
Bus. 416-239-2193  
fax. 416-239-6228  
email: ruefulsaab@hotmail.com

**San Diego SAAB Owners' Group**

Chris Rogers  
10559 Lansford Lane  
San Diego CA 92126-  
619-530-0019  
Fax: 619-530-0096  
Email:annexus@abac.com

**Southern California SAAB Club**

Paul Florance  
126 1/2 Main St.  
Seal Beach CA 90740-  
562-493-6707

**Tristate SAAB Club (OH, KY, IN)**

Paul Arel  
9864 Baughman Rd.  
Harrison OH 45030-1771  
513-367-9864

**Utah SAAB Club**

Chris Cox  
P.O. Box 526105  
Salt Lake City UT 84152-6105

**Western Pennsylvania Saab Club**

Andy Bittenbinder  
9433 Katherine Drive  
Allison Park PA 15101-  
412-366-6165

**THE SWEDISH SOLUTION, INC.**

**Servicing SAAB  
Since 1982**

**Buy Parts From Us... Why?  
Better Value, Better Service,  
& We've Got-Em !**

- ◆ Most Orders Shipped Same day (on in stock items)
- ◆ Experienced Parts Specialists
- ◆ Lifetime Muffler / Starter / Alternator / Steering rack Warranty Available
- ◆ Over 6,000 different part numbers in stock for SAAB 900, 9000, 9.3 and 9.5 series
- ◆ New & Remanufactured Parts Available
- ◆ Tried and Tested Parts
- ◆ NINES Member Discounts
- ◆ If we don't have it, we will get it for you
- ◆ We install everything we sell, so we know what works. Call us for all your parts needs

**Call Now - For Quotes**

Toll Free 1-888-669-PART or (7278) Fax (440) 248-0288

THE SWEDISH SOLUTION, INC.  
27999 Miles Rd. • Orange Village, Ohio 44022

VISA / MC / Discover / AMEX

E-Mail swedish@bright.net http:// www.swedishsolution.com

**WE STRAIGHTEN DENTED ALLOY RIMS!**

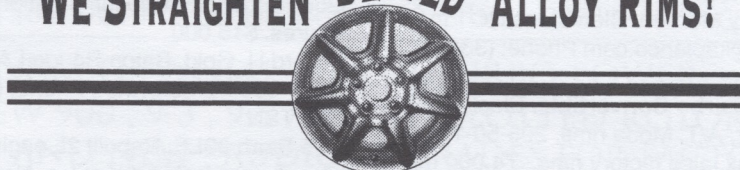

**We turn your dented rim into a straightened rim at mfg. specification with our patented machine!**

**\$99.99 Per Rim (Incl. shipping back to you)**

**Service Above & Beyond  
9 Summer Street, Ashland, MA 01721  
Call 1-508-881-1999**

**SAAB SWAP CLASSIFIED AD RATES:**

Ads offering parts or Saabs for sale, or wanted, are available to members and non-members. Ad rates are for 25 words - more less - EXCLUDING your name, telephone number, address, etc. Extra words are charged at \$1.00 per 5 extra words. Classified ads MUST be prepaid. Ad rates are as follows:

TYPE OF AD	SUBSCRIBERS	NON-SUBSCRIBERS
CAR FOR SALE	\$10.00	\$15.00
PARTS FOR SALE	\$5.00	\$7.50
WANTED ADS	\$2.00	\$3.00
COMMERCIAL AD	\$10.00	\$15.00

**Note: "TSN" before an advertiser's name signifies that a photo of the sale item was on TSN (http://www.saabnet.com) at the time of the ad's placement.**

**DEADLINE:** 15<sup>th</sup> of every odd numbered month for inclusion in the next issue.

Mail ads with full payment to: Saab Swap  
2389 Chestnut Hill St. NW  
North Canton, OH 44720-5822

NINES can also place your ad on The Saab Network (internet classified ad) for you. Include the TSN ad rate, \$15.00 for cars, \$10.00 for parts, for up to 150 words. We can also scan and submit your photograph at no extra cost. Please enclose SASE for return of photographs, if wanted.



# Saab Swap

## 9000 For Sale

**1996 Saab 9000 CSE**, 2.3L Turbo, Auto Trans. 31,000 Miles, Scarabe Green, All power amenities. Maintenance records, Asking \$20,475 Call Dave 210-673-9763, TX

**1993 Saab 9000 Aero**, Imola red, standard, 100,000 miles. personal car, hit on left front. repairable or excellent parts car. \$3,200 Contact: John C. Clark, Irvington NY Email: citygear@aol.com Phone: (914) 591-8608

**1989 Saab 9000 Turbo CD 2 DOOR**, 14,500 miles, standard, Concept car built for SAAB by ASC Corp. The only one of its kind in the world. Suspension being lowered, stunning in every detail, \$22,500 or best TSN Bob Fallis, Rochester Hills MI Email: ref5@teleweb.net Phone: (248) 853-7978

**1988 Saab 9000 Turbo**, Rose Quartz, standard. One Owner, carefully maintained, very clean. 188,000 KM = 117,000 miles. C\$5,500 or US\$3,750 Contact: Christopher D Sanderson, Toronto, Ontario CANADA Email: chrissand@sympatico.ca Phone: (416) 573-6933 TSN

## 900 For Sale

**1995 Saab 900S**, 5dr, Black, tan leather, 5 spd, new tires, 76,000 miles, all options, runs and looks like new, no dents, dings, or rust, maintained by Saab mechanic, always garaged. Retail over \$14,000. \$10,900 obo. TSN Bobby Monroe, Clemmons NC Email: bmonroe@kaplanco.com Phone: (336) 766-1976

**1991 900 Turbo Convertible**. Black/black/tan leather, A/T, Moda rims. 205-50-16 Falken Ziex, also factory rims. 74,000 mi, \$11,000. North Central Indiana, TSN Robert Reynolds, (219) 546-5665, fax (219) 546-5845, reynoldsatdia@compuserve.com

**1989 Saab 900 SPG** Black with Grey leather, 139,000 miles, Body great (garaged). rebuilt trans, new clutch, A/C ball joints, regular oil changes, records, 900 manuals and snow tires. Needs headliner. TSN Scott Dillingham, Elmhurst IL Email: scott\_dillingham@smi-ch.com Phone: (630) 932-3035

**1988 Saab 900 SPG Convertible**, (SO RARE) black with black top, grey leather, 5spd, 158K miles, maintained by saab mechanic, serviced every 3000, effect inside and out, no dents, dings or rust, alwaysgaraged. \$7500 obo. TSN Contact: Bobby Monroe, Clemmons NC Email: bmonroe@kaplanco.com Phone: (336) 766-1976

**1987 Saab 900 S hatchback**, 114,000 miles, 5 speed, blue w grey interior. VGC all books and records. Sunroof, cruise,

heated seats, alloy wheels, PS,PB,PW,PL, rear spoiler. Non-smoking, bought new. \$3,500 Robert W. Adriaansen, Cherry Hill NJ Email: rwa@adriaansen.com Phone: (609) 424-4306 TSN

**1987 Saab 900 S** 16V Hatchback, Rose Quartz with Maroon interior, 126,700 miles. Original non-smoking owner. 5-Speed, rear spoiler, center armrest, dash mat, after market security alarm. Excellent interior. Engine rebuilt at 119,000. \$4,000 TSN Stephen Wynne, Plano TX Email: srwynne@airmail.net Phone: (972) 996-7852

**1986 SAAB Turbo Hatchback (900T)**; Rose Quartz; stick shift, fully equipped. 262,675 mostly road miles; 2nd owner; always religiously maintained; all maintenance records, including oil and filter changes; strong engine, very good mechanical condition - burns no oil between 3000-mile changes; no dents, recent beautiful 2-stage paint; very good tires & brakes; armrest, wired for CD player; alarm system; \$2600. George Schmitt (407) 727-1228.

**1984 900 Turbo 3 door**. Auto, whale tail, sun roof, Shelby allowy wheels. \$300. Russ Brown, Lyndhurst, OH 44124. (216) 382-4824 home or (216) 692-1296 work.

**1980 Saab 900T 5 Door Hatchback**, 32,000 miles, green, A/T Completely rebuilt from metal chassis, "built" 84 motor high compression bored cylinders, intercooler. \$25000 spent. Full documentation including pictures. \$15,000 Richard H. Gold, Baton Rouge LA. Email: neuro\_doc@prodigy.net, Phone: (225) 767-0900 TSN

**1975 Saab 99LE**. Rebuilt 2L engine, zero miles, transmission, 3K miles. New suspension, brake hardware, engine mechanicals. Body solid, interior fair, needs electrical work to run. Charles Mass, Colchester VT Email: massc@war.wyeth.com Phone: (802) 879-5781

**1970 Saab 99E**. 4-dr, fuel injected, low mileage. Silver mink color, deep red interior. Sweet car needs loving home. Partially restored, owners manual and service records. \$3200. TSN Kim Stephens, Knoxville, TN. (423) 524-2899

## 93, 95, 96, Sonett for Sale

**1974 Sonett** Good Shape, needs paint, \$2000 obo, **1973 Sonett** engine OK. Trans bad, best offer. **1971 Sonett** body chassis only, best offer. **1968 Sonett** bad trans, best offer. Terry Waters, Malibu, CA. 818-889-9390

Restoration package, **1973 Sonett, 129K and 1974 Sonett, 94K**, with Weber two

barrel. Also a **rust free frame** with some rear damage. \$2400 for all. Calvin Van Sant, Kirkwood PA Email:

van123@epix.net Phone: (717) 529-6956

**1972 Saab 95 (wagon)**. Older complete restoration, mechanical rebuild by a local Saab club president. 900 front seats, Sonett Wheels. John S. Lotz, SW PA. (724) 934-2769.

**1970 Sonett III**. Strong drivetrain, good interior, new brakes, little rust in rockers, needs paint, cost storage \$1800. M Songer, 575 Forest St., Marion, OH 43302. (740) 375-4465 or (614) 272-2237.

Attention Sonett III restorers. **Completely rebuilt Sonett III FRAME**. All questionable panels replaced with our 18 gauge new panels. NO RUST. Painted and ready to be installed. \$2500 plus paletizing and shipping. Jack Ashcraft, 4305 Dark Hollow Road, Mefford, OR 97501. (541) 779-0783 **V4**, 2bbl carb, MSS exhaust, rustfree chasis, new paint, front suspension & engine bay detailed, new clutch, rebuilt trans & everything under hood. Tom Donney, Fort Dodge IA Email: tdmsaab@donneysaab.com Phone: (515) 955-2378

**1967 Saab Sonett #215**. Former SCCA race car from TX. "Convertible" with plexi windscreen. Sound chassis. Not run for long time. Engine still turns. TSN. Ed Bocko, Sharon MA Email: ebockoprotran@worldnet.att.net Phone: (781) 784-7663

**1967 96 2-stroke**. No rust, very good condition inside and out - took 3<sup>rd</sup> place in Concours at Saab Convention 1998. \$4000. Terry Bailey, Bham, Al. M-F (205) 324-9756

## Parts For Sale, Wanted.

**Parting out Saabs:** '84 900, '85 900T 16V, 86 900 Base, '86 SPG, '87 900T 16V, '89 900S 16V, 94-98 900, 900S, 900T. Drivetrains, Interiors, Body Parts, Suspeinsion, Wheels, Misc. Parts & Accessories. Dave Anelli, Wallingford, CT. 203-949-4881.

**Transmission for sale:** 1983 5-speed rebuilt 30,000 miles ago. Also valve cover and dipsticks for up to '85. \$300 or best offer for all. Ian Prees, Chelmsford, MA. Chelmsford, MA (978) 250-3803. Email: hiscoop@aol.com

**Exchange Group 6 Box for a stock SPG Red Box** between the years 1989 and 1992. You must include \$50 with your Red Box since the G6 Box is an expensive aftermarket item. G6 box is 1 1/2 years old. Patrick Riordan, Watertown MA Email: priordan@schwartz-pr.com Phone: (617) 924-8836



**Four 7x15 Schuessler** sport wheels (made by Borbet) with locking covers, fit late 80's and early 90's 900 and 9000 - \$500; Heuschmid 9000 sport suspension - Koni sport shocks and springs - \$300; Early 9000 Euro headlights - \$100 TSN Milton Horst, Seattle WA Email: milthorst@w-link.net Phone: (206) 935-4143

**Mostly V-4 parts.** Used and new. Over 1000 parts. No large or body parts. Over 600 part listing. Estimated value at 1989 prices over \$20,000. 24 page print out or floppy disc available for \$5. Can also email database. Serious inquiries only. Call to discuss offers. Dave Kronen, Canoga Park PA Email: kronen@boneclones.com Phone: (818) 709-7991

**V-4 Parts:** 4 Soccer ball rims - no centers - bolts incl. \$150 plus shipping. Holley/Weber 2bbl carb & intake manifold incl gaskets. \$500 plus shipping. **2-stroke parts:** Tri-carb manifold w/carbs \$50 plus shipping, generator, \$25 plus shipping. M. Songer, 575 Forest St., Marion, OH 43302. (740) 375-4465.

**Help Wanted:**

**Andrews Inc. of Princeton**, a leading Saab independent shop, is seeking a full time auto body technician and/or painter. We offer top pay and benefits plus the

invaluable benefit of working on Saab only collision work, restorations, and custom work in a modern, well equipped shop. Join the team on the grow for 26+ years in the Saab world! Please e-mail chuck@andrewsofprinceton.com, fax resume to (612) 389-3875, or call Chuck or Don at 1-800-882-7220

**Miscellaneous**

**Wanted Old rally Equipment:** Heuer stopwatches + wristwatches; (Montecarlo, Mastertime, Sebring, Autorally, Super

Autavia, Etc.), Halda Speedpisot, Twinmaster, Tripmaster, 3 stopwatch clipboard, Curta Calculator. Macgoodies@aol.com. Castle, Box 2030, Redondo Beach, CA 90278, USA. (310) 793-0129

**Back Issues of NINES through #239.** See NINES #240 or 241 for issues in print, prices for mailing to foreign addresses, and other details. \$6.00 per issue, any 10 for \$35, or all remaining issues for \$65, to US addresses. Saab Club Extras, 7675 Bear Trap Junction, Saginaw, MN 55779-9672.

**SAAB OWNERS BEWARE**

Traffic police assume Saab owners have above-average incomes, which is why they target you for traffic tickets. They think you're more likely to pay up than to contest their revenue-generating practices in the courtroom. However, they overlook the fact that Saab owners are more educated and more motivated to stand up for their rights.

**Let us help you fight that ticket!**  
call the

**NATIONAL MOTORISTS ASSOCIATION**  
for Membership Information Now!  
**1-800 SPEED TRAP**  
or visit our Web Site at [www.motorists.com](http://www.motorists.com)



**National Motorists Association**

402 West 2nd Street, Waunakee, WI 53597  
Phone: 1-608-849-6000, Fax: 1-608-849-8697  
E-mail: [nma@motorists.com](mailto:nma@motorists.com)

We're the organization responsible for the repeal of the 55 mph National Maximum Speed Limit. We could do much more with your support. Consider joining the one motorists' rights organization that truly represents your interests in issues such as emissions inspections, auto insurance, photo RADAR, red light cameras and speed traps. Most importantly, members have access to ticket-fighting assistance, attorney referrals and more information on fighting tickets than is available anywhere.

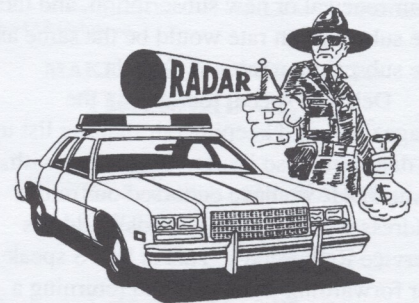

9-3 : 235 HP up from 185 HP    9-5 225 HP up from 170 HP    235 HP 91-92 9000 Turbos    200 HP 9000 CS

NEW FOR 2000 : LIGHT ALUMINUM FLYWHEELS , NON-TURBO POWER , SKID PLATES FOR 900 , 9000 , NEW 900 , 9-3 , 9-5 AND 99 , SLOTTED ROTORS , LIGHTING UPGRADES FOR OLD AND NEW , AUDIO UPGRADES FOR FACTORY SYSTEMS , IGNITION UPGRADES , DASH INLAYS FOR OLD 900 , AND MORE .

OF COURSE WE HAVE ENGINE MANAGEMENT UPGRADES FOR ALL TURBO CARS . WE OFFER 10 TO 40 HP INCREASES FROM ELECTRONICS ALONE . WE NOW SELL REBUILT TRANSAXLES WITH FINAL DRIVE SETS NEEDS . OFFERED

**Abbott Racing USA**

AND UPGRADED YOUR CHOICE OF TO FIT YOUR ON AN EX-

CHANGE BASIS , WITH OR WITHOUT PERFORMANCE UPGRADES SUCH AS ABBOTT RACING'S EXCLUSIVE QUAIFFE LIMITED SLIP DIRTS FOR SAAB CARS.

CALL TO RECEIVE THE LARGEST SAAB PERFORMANCE CATALOG AND CHECK OUT OUR NEW HUGE WEBSITE UP SOON AT [WWW.ABBOTT-RACING.COM](http://WWW.ABBOTT-RACING.COM)

406-273-7974    FAX 406-273-3085    E-MAIL US [arusa@montana.com](mailto:arusa@montana.com)

PO BOX 879 FLORENCE , MT 59833

Road or Rally sport suspensions

Always the originators of the fastest , funnest , safest Saab equipment



Mailing related issues have come to dominate our attention during the past couple of months. First, we must regretfully increase the subscription rates by US\$4.00 per year for "Pacific Rim" subscribers: those from Japan and Korea in the north to Australia and New Zealand in the south. Air mail postage to that region is precisely that much greater than the postage to Europe, and this is using preferred "printed materials" rates. Even with the increase, the Postal Service gets more than half the money! If any "overseas" subscriber, either in Europe or the Pacific Rim, wishes to have NINES delivered by Surface Mail (four to six weeks, according to the Postal Service), please note that on your renewal or new subscription, and then the subscription rate would be the same as the subscription rates to Canada.

Delivery speed, forwarding the magazines, and keeping our mailing list up to date were also issues. Beginning with issue #241, we have endorsed our return address with the magic words "Address Service Requested". This is USPS speak for forwarding the issues and returning a form with the new address to our office. Please do not rely on this service if you move, because it delays delivery of your magazine, exposes it to more wear, possible damage, and possible loss. Notify us at least 8 weeks before your change of address, as requested in the masthead, and your magazine will be sent to your home, not your previous home. Forwarding could add two or three weeks to the time it takes for your magazine to be delivered. I claim this because our statistics show that it takes between two and three weeks for the magazine to reach most subscribers. Now, if you've just moved across town, it should take less time. "Should" is the operative word here. We can not guarantee delivery if we do not have the correct address. It is surprising how many renewal cards are returned for "no forwarding address", or "forward time expired," meaning more than 12 months after the move.

In true "Catch 22" fashion, you are reading this because we have your correct address, or at least because the issue was forwarded and we will soon have your correct address, courtesy of the USPS. But please, please, please send us your new address as soon as you know what it will be, along with the date you will be moving.

Email is fine, snail mail is fine, fax is fine, and while we prefer that you not call on the phone to update your address information, it's better than not contacting us at all.

If our cover looks like it was purchased by Mark Kline, in a sense it was. The Rocky Mountain Saab Club, hosts of the 1999 Saab Owners' Convention, requested exhibitors and others to donate items for their "Presenters' Auction", the proceeds being used to help defray the expense of hosting the Convention. We donated the Cover of Nines, and Mark was high bidder. The next afternoon we took several photographs of Mark and his Concours winning "Pearl White SPG," using the Rocky Mountains as a backdrop. Mark preferred a photograph taken in his shop.

Much of this issue is devoted to covering the 1999 Saab Owners' Convention. Our own convention experience was enhanced by a Red 9<sup>3</sup> Convertible that we rented from Budget. Did you know that Budget rents Saabs at most of the major metropolitan airports in the USA? They rent in the "Premium Automobile" class, but by special arrangement (that is to say, an awful lot of arm twisting by Ms. Lisa Uhl of Saab's Public Relations Department) Saabs were available at Denver International Airport during the Convention week for about the same price as a Ford Escort. To summarize the experience: unlike every other Saab I have owned or driven, the top goes down! And very easily, too. Just push the button and stay out of the way. On the other hand, an awful lot of passenger and cargo space is lost to the top operating mechanism and space to store the top. Aside from those two hard-to-miss observations, the car's performance, handling, and comfort were right in keeping with Saab's great product line.

We also received a lesson in local driving hazards. Both headlights were cracked, this despite any indications of hard use or collision. Tony Leopard, Service Manager at Mike Shaw Saab in Denver, explained it to us. Rather than salting the roads in the winter, Colorado uses sand, or as Tony called it, "fine gravel." This pits the paint, the windshields, and the headlights of cars. Then if the cars are washed when the headlights are hot, they crack because of the pits. Thanks to daylight

running lights, Saab headlights are always hot when they find their way to the Budget car wash, and thus the cracks. Some of our advertisers sell adhesive polyurethane protection pads for headlights, and residents of Colorado would be well advised to investigate that product.

New in this issue is the Readers' Survey Column. This was motivated by feedback we received from some Convention attendees that our magazine could use some material of broader interest than the technical articles which have served our members over the years. We agree. But this does not mean that we are turning away from our traditional articles. We are going to continue to publish repair, restoration, and performance articles, but these will be balanced somewhat for the benefit of newer subscribers. Also look for other new features: big repairs that could have been minor, if only; "crash of the (bi)-month; and our "Repairman Poet".

Another reader contacted us concerning the absence of Saab Parts and Service Bulletins (PSI) in the past two issues. To be sure, we believe that publishing this information is important, but during the months preceding issues #240 and 241, the PSIs we received were applicable to only a few cars. The bulletin we printed in this issue apply to a large number of cars, and we will continue to print those bulletins with wide application. Other regular columns may take turns on the shelf as we balance the subjects we print in an issue - such as this issue's "spotlight".

Finally, after a dozen articles on the restoration of Sonetts, Bruce Turk is taking a well deserved respite. In his place, we will start a series by Clifford Quan covering his restoration of a "Classic" 900 SPG next issue. With the oldest members of the 99/Classic 900 series of cars now 30 years old (25 years qualifies a car for Historical Vehicle status in Ohio), restorations for cars in this series may well be considered. Another activity for owners of 99/Classic 900 series vehicles is upgrading older cars to newer specifications. Past issues of NINES covered back-fitting 16 valve engines into 99's. 99's and Classic 900's can be upgraded with either ventilated front brake rotors or with the 9000 style brakes with which 1988 and later Classic 900's left the factory. And, as always, we urge our readers to write.



## MEMBERSHIP/SUBSCRIPTION

Address Change Only (please attach old address label)

NAME \_\_\_\_\_

ADDRESS \_\_\_\_\_

CITY/STATE/ZIP \_\_\_\_\_

HOME PHONE \_\_\_\_\_ WORK PHONE \_\_\_\_\_

E-mail address \_\_\_\_\_ Fax# \_\_\_\_\_

### SAABS CURRENTLY OWNED:

Example: Year 1995 Model & trim 900 SE Body style 5 door  
 Engine 2.5 liter V6 Transmission 4-spd auto VIN# YS3DF58VXS2000000

#1: Year \_\_\_\_\_ Model & trim \_\_\_\_\_ Body style \_\_\_\_\_

Engine \_\_\_\_\_ Transmission \_\_\_\_\_ VIN# \_\_\_\_\_

#2: Year \_\_\_\_\_ Model & trim \_\_\_\_\_ Body \_\_\_\_\_

Engine \_\_\_\_\_ Transmission \_\_\_\_\_ VIN# \_\_\_\_\_

Please include additional cars on a separate sheet of paper. VIN for VINTAGE cars only (92,93, 95, 96, or Sonett). Visit our website: <http://www.saabclub.com> for information on owner surveys.

Brief comments here; use another sheet for longer comments.

Membership fees for the SAAB Club of North America/NINES are as follows:

New membership \$34.00US  
 Renewal \$30.00US

### TO CANADA or overseas surface mail

New membership \$38.00US  
 Renewal \$34.00US

### TO EUROPE AIR MAIL

New membership \$42.00US  
 Renewal \$38.00US

### PACIFIC RIM AIR MAIL

New membership \$46.00US  
 Renewal \$42.00US

Please check appropriate box(es)  
 (Canadian and International — Money order or check payable on a U.S. bank only.)

New members receive the most recent back issue of NINES and two SAAB Club decals.

### MAKE CHECKS PAYABLE TO "THE SAAB CLUB"

Mail to: Membership  
 The Saab Club of North America  
 2389 Chestnut Hill St. NW  
 North Canton, OH 44720-5822

Phone: 330-497-0346 9 to 9 Eastern  
 fax: 413-740-5583 email:nines@neo.rr.com

**Subscribers:** Please help to make NINES stronger by encouraging your fellow Saab owners to become members of the Saab Club of North America. Our "Bandito" promotion in NINES #240, which you can also see at our budding website, <http://www.saabclub.com>, shows how you can be rewarded for helping.

Saab Parts @ **Click Here!** Townsend Imports  
 Great Prices Thomas Townsend & Ywan Mason  
 Hosts of The Saab Network Technical Chat

<http://www.townsendimports.com>

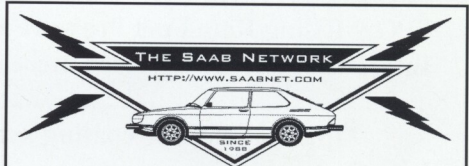

The Saab Network  
<http://www.saabnet.com/>

Bulletin Boards - Photos -  
 Mailing Lists - Polls - and more  
 On the Internet since 1988

## Paragon Performance

The Leader in High Performance  
 Automotive Hose, Fittings and Adapters

**We Specialize in Saab Stainless  
 Steel Braided Brake Line Kits!**

Prices Start at \$77.00 for a 4 line kit

We also offer Stainless Steel Braided Hose, Aluminum  
 Fittings and Adapters for Fuel, Oil & Transmission Lines

Come visit us at:

<http://www.paragonperformance.com>

1-800-270-0333



New and Used SAAB parts

VISA/MASTERCARD ACCEPTED  
 TOLL FREE ORDER LINE

1-800-882-7220

Info: 612-389-3805 Fax#: 612-389-3875  
 35558 Brickton Road, Princeton, MN 55371  
[www.andrewsofprinceton.com](http://www.andrewsofprinceton.com)  
 E-mail Chuck@andrewsofprinceton.com

No longer just a rumor!

Limited-slip  
 Differential

fits 99 and 900, 1975-93

S&J Automotive

1491 Howell Mill Rd  
 Atlanta GA 30318

404-351-SAAB

jack@mindspring.com





PRESORTED STANDARD  
U.S. POSTAGE  
PAID  
PERMIT #282  
Red Wing, MN 55066

2389 Chestnut Hill St. NW  
North Canton, OH 44720

ADDRESS SERVICE REQUESTED

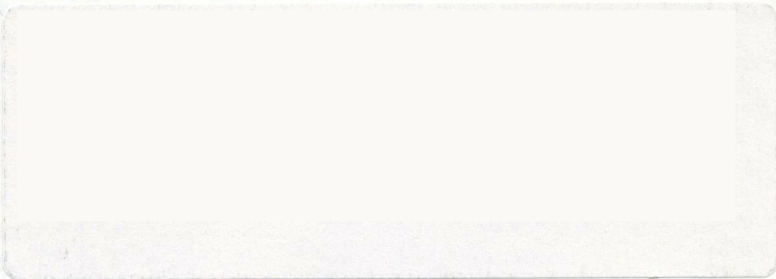

#242 November, 1999

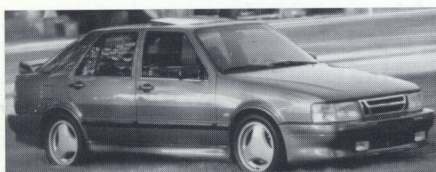

# SPG9



6450B VIA AVENUE, ATASCADERO CA 94322

- RED LINE MTL 75W/80W or AMSOIL 75W90 ..... (3qts. shipping & handling included) ..... \$29.50
- Air Inlet Kits (Please call for additional applications) ..... '85 to '97 900 & '86 to '89 9000 ..... \$69.00
- APCs (exchange) ..... Most Aggressive Modified Turbo Controls Available! Stage 1 32+ H.P ..... \$295.00
- ..... Stage 2 40+ H.P ..... \$350.00
- Fuel Pressure Regulator ..... 2.8 bar or 3.0 bar(your choice) ..... \$65.00
- SPG 9 Rising Rate Fuel Pressure Regulator ..... Power + Milage Awesome Unit! ..... \$249.00
- Intercooler Air Ducts(Huge increase '85 to '88 &some gain '89 to '93) 900T ..... Steel ..... \$150.00
- ..... Aluminum ..... \$195.00
- Optional powder coating available, any color and black or red wrinkle finishes ..... add ..... \$39.00
- Intercooler Air Dam ..... (updated and now in black wrinkle finish) '85 to '93 900T ..... \$49.00
- Big Bore Throttle Bodies (Please call for additional applications) '85 to '93 900 & '86 to '91 9000 ..... \$225.00
- BOSCH 20 psi Blow Off Valve ..... 900T & 9000T ..... \$49.00
- SPG 9 Modified Distributor Vacuum Advance/Retard - less turbo lag (Exchange) ..... \$79.00
- NOLOGY Hot Wires Ignition System ..... with BERU 99.9% Silver spark plugs and SPG 9 Coil ..... \$195.00
- SPG 9 18 psi Waste Gate Actuator ..... Air Research Turbo's 900T & 9000T ..... \$95.00
- STAGE 1 SPG 9 Turbo (complete unit exchange) all custom applications 99, 900, 93, 9 5, & 9000 ..... \$749.00
- INTRAX Lowering Springs ..... Space Age Design! Lowers 900 by 1 1/2 inches (38 mm) ..... \$295.00
- KONI Shocks The Very Best and Worth It! '68 to '80 99 and '78 to '93 (to '94 Convertible) 900 ..... \$449.00
- ..... '86 to '98 9000 (includes our modified struts - exchange) ..... \$595.00
- Chassis Braces (new product) ..... 9000 5 Door '86-'89 Front & Rear ..... \$295.00
- Sway Bars (available soon) ..... Please call for 900 applications ..... \$249.00
- Stainless Steel Brake Lines ..... (Shrink tube blue) also available in Red, Black, & Clear ..... \$125.00
- Cross Drilled or Grooved Rotors in Cad Gold with Hi. Perf. Pads ..... \$495.00
- CENTER FORCE Clutches..(light pedal effort & the most clamping force avail!) '83 to '89 .. 900 ..... \$295.00
- ..... '90 to '93 900 (to '94 convertible) and '86 to '89 9000 ..... \$395.00
- External Voltage Regulator Kit ..... Fits BOSCH Alternators ..... \$75.00
- Two Speed Cooling Fan Switch with wiring adapter ..... \$39.00
- Improved Lower 900 "A" Arms (exch) .... boxed, tig welded, stress relieved, (powder coated avail) ..... \$295.00
- CALL... Stainless Steel Cat-back exhaust - '83-'93 ('94CV)900...CALL...Modified 99/900 Clutch Pedal... CALL

**CONTACT US @ (800) 847-4996 (SALES) PLEASE MENTION NINES!**  
**VISIT [spg9.com](http://spg9.com) TECH. SUPPORT (805) 461-1090 pst E-Mail [spg9@fix.net](mailto:spg9@fix.net)**