

NINES

THE SAAB CLUB NEWSLETTER

\$4.95
August
1992
no. 215



Bruce Welch and his Concours Winning 1960 GT750.
Tim Winker photo.

New Column: Professional Perspective	page 9
1993 Saabs: A New 9000 & new pricing	page 13
Saab's Trionic engine management system	
Driving impression - '93 9000 CS	page 17
National Convention Coverage	page 18
New Products: 900 Repair Manual, Denim seat covers,	
New computer software for auto enthusiasts	page 26
The Government wants your old car!	page 33

Regular departments

Letters	page 3
Saab Klinik	page 7
Service Subjects	page 10
Saab News	page 12
Jack Ashcraft	page 22
Technical Talk	page 24
Saab Swap	page 36

Regional Club News

This issue sent to the printer on Oct. 1, 1992

Appalachian SAAB Club

Oct. 31 - Halloween Halocast, location TBA. Wendell Francis, 615/397-2172.

SAAB Owners' Club of Canada Inc.

Oct. 3, 4 - Saab Club/BMW Club school at Le Circuit Mont Tremblant (St. Jovite, Quebec). \$300/person for both days.

Oct. 23 - Driving school. Shannonville Motorsport Park (Belleville). Club membership, \$125/person per day. John Casey, 519/476-4320.

Milwaukee SAAB Club

Oct. 26 - Elections & General meeting, at My Place, 76th & Bluemound, 7:30pm.

SAAB Club National Capital Area

Oct. 14, Nov. 9 - Monthly meetings, Davis Library, Bethesda, MD.

Southern California SAAB Club

Oct. 10 - A&B Saab Service, 8th Anniversary Picnic, Mission Bay, CA. 619/295-6888

Oct. 24 - BBQ Octoberfest
Paul Florance, 310/493-6707.

For all car clubs

Oct. 11 - Out of the Woodwork 12, Round Valley Recreation area, Lebanon, NJ. Club displays welcome. Sponsored by the TVR Car Club.
For details: 301-986-8679.

New Club - Northern California

If you'd like to help form a San Francisco Bay Area chapter, please contact Douglas Morse
25291 Morse Ct.
Hayward CA 94542
510 / 582-1858

SAAB Club of North America

2416 London Road, Unit 900
Duluth, MN 55812-2221

Phone: 218/ 724-1336,
9am - 6pm Mon - Sat CST
Fax: 218/ 728-6307

NINES Editor & Publisher:

Tim Winker

Editorial Ass't / Membership

Michelle Swanson

NINES is published bimonthly as a service of the SAAB Club of North America. The SAAB Club is not affiliated with Saab Cars USA, Inc. or Saab Automobile AB.

All material copyright 1992, SAAB Club of North America. Material may be reproduced only with proper credit to the author and to "NINES, the SAAB Club Newsletter". The opinions and views expressed in articles are not necessarily those of the SAAB Club and its newsletter, NINES.

Editorial contributions are welcome. All material submitted is assumed to be for publication unless clearly labeled otherwise. Double-spaced typewritten articles are preferred, but most anything is acceptable. We cannot answer every inquiry and reserve the right to edit materials submitted.

Those wishing to submit articles or letters on 5/4" or 3 1/2" IBM-formatted disks, please convert to ASCII text files (<filename>.TXT). Please include a printed hard copy, and a SASE if you want the disk returned.

Photos: Preferred format for photos is black-and-white, in 5"x7" or 8"x10". Good contrast color photos can usually be accommodated, no smaller than 3 1/2"x5", please. Photos used on the cover will be rewarded with a one year subscription to NINES.

CHANGE OF ADDRESS: Eight weeks notice is required for change of address. Please send new address and old address, including zip codes, to the SAAB Club at the address above.

RETURNED CHECKS: There will be a fee of \$10.00 charged for checks returned for any reason.

Gripen Grin

by Andy Saksa

reprinted from the Saab Sport, Milwaukee Saab Club

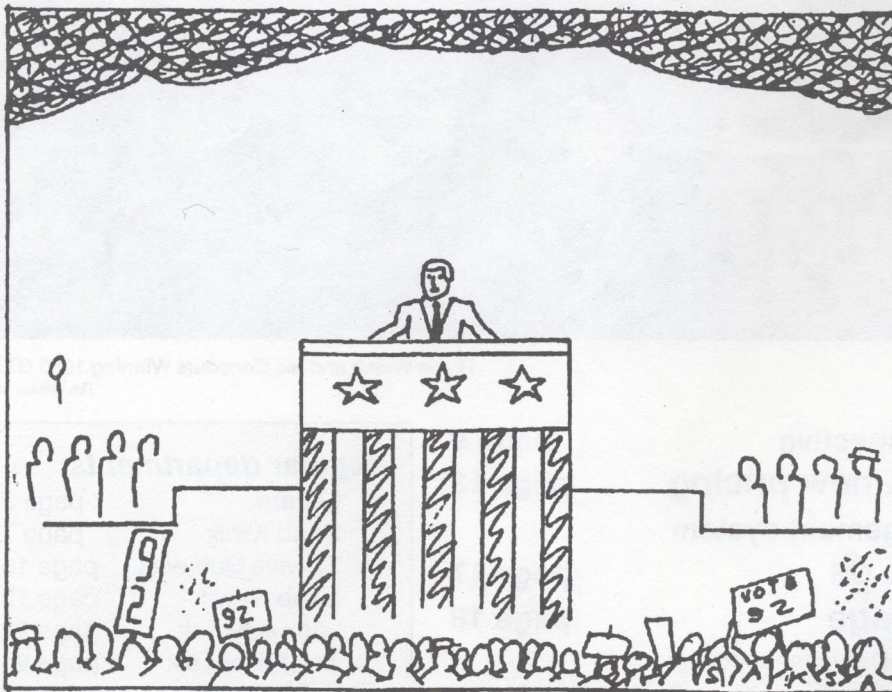

Yes friends, it's true, I did once own a two-stroke... but I didn't inhale!

Letters to NINES

Convention Kudos

Thanks to the Central Ohio Saab Club for a great National Convention! Dan Orzano and crew did a fine job in organizing a class event. From facility to food, it was beyond our expectations.

For those who chose to or weren't able to attend this year's event, you missed seeing well organized and presented tech sessions from experts across the country. You missed an excellent opportunity to view what I think must have been about 200 very nice Saab, whether you like old or new models, and the auto cross. But most of all, you missed meeting and visiting with old friends and making new ones. I even got a picture of Eric Carlsson with my ten year old grandson, which will make for an interesting memory.

I hope everyone is making plans for attending next year's convention. I know the Milwaukee Club will do a great job.

Chuck Andrews
Princeton, MN

Adventures with Eric

First of all, I'd like to thank the committee for the convention in Columbus. It was very well done and it appeared that those who attended had a wonderful time. For those of you who have never attended a convention, you really have missed a unique experience.

Speaking of unique experiences, I'd like to tell you of our adventures with Eric. Our daughters have always had a thing about naming our cars. The name "Eric the Red" came about because our car is Swedish, red and very obviously a male car. The car is a Sonett II - number 242. This is not a story about Erik Carlsson.

We arrived at the convention with the car overheating and "spitting up." In taking the car out the next day, same problem. The wonderful Larry Williams and several others spent a goodly portion of the afternoon and early evening trying to figure out the problem. A thermostat was found at fault and taken out.

When we packed up the car to leave the next day, the car wouldn't start. Pat Tennis, in typical Saab helpfulness, poked around and we eventually got the car

started. Mind you, the overheating problem hadn't been resolved and we're talking a long trip. We live about 50 miles northwest of Chicago. It's 11:30 a.m. and we're finally off!

Every hour, for three hours, the car faithfully overheated. We'd pull off, add water, and off we'd go. Remember now that we're not shutting this car off for any reason, so I'd sit in the car and keep the engine revved up. We even got gasoline this way. For some strange reason, into the fourth hour, the car seemed to maintain a constant temperature but our eyebrows *really* went up when the gearshift lever started to pop out of gear at speed. This happened about four times and then it too mysteriously stopped. All the while, I kept my eye on the clock on the dashboard. I'm not a time watcher, but if the clock doesn't work, that means we have no brake lights. Guess what kept stopping which meant a couple of quick stops to clean up the fuses.

In the mean time, we're getting closer to Chicago. The moment of monumental decisions - tollroad or no tollroad. The car was working extremely well by now, so we did the toll road thing.

We hit I94/I80 on the south end of Lake Michigan along with the rest of the world, bumper to bumper, stop and go. Eric performed like the little trouper that he is, maintained constant good temperature, didn't foul out, kept its brake lights on and got us home by 7:15 p.m. Sunday evening.

When we pulled into our driveway, Al had a smile from ear to ear and said, "Eric can sure make you nervous but he always comes through."

There were no atheists on this trip!

Ruth Sutton
Barrington, IL

Late news

The 1992 Annual Convention was the first I attended, and both my son, Davin, and I had a great time. I enjoyed the technical sessions, he made some new friends among other children who attended, and we both like seeing the amazing variety of Saabs. The only criticisms I had was not knowing in advance that the autocross would be an untimed amateur event and the confusion about the side tours. If I had known, I would have come prepared to participate in the autocross, and would have avoided sending money for the tour bus. (Those who sent money in error have been promised a refund but so far I have not received it).

The Convention is THE major annual event of Saab enthusiasts and as such should receive *substantial* pre-event coverage in NINES. Unfortunately, none of the events were described in detail in either the April issue (when details were probably not yet known), nor the June issue. This would have cleared up the confusion about the autocross and tours. A description in the June issue may have been moot anyway, since apparently many members did not receive it before the Convention.

One of the advantages promoted for the six issues per year plus the swapsheet concept was that it would allow issues to be out on time. The May swap sheet arrived in June. My June issue arrived August 5th, 2 days after my September Road and Track. Aside from that, recent issues have been full of typographical errors, suggesting that they were put together in a hurry.

It is very disappointing to me when I reach into the mailbox with great anticipation, and find that my newsletter is not there. It is an even greater disappointment when I respond to an ad in NINES and find that an advertised item has long ago been sold, or that a special offer is over before I have received word of it. I can imagine how an advertiser feels.

Having been briefly in the publishing business, I know the tremendous difficulties entailed in putting together a good publication. And goodness knows, there are many deadlines I have not met in my life. (I would have joined the Procrastinators Club but I just can't seem to get around to it). But the news has time value, and particularly in the case of the convention, I think an effort should be made to get out the newsletter and the news on time. I hope we can count on it in the future.

Jeff Baker
Fairport, NY

Though the cover date may be a couple of months late, the news and ads in each issue are as current as possible. For instance, this issue is labeled August, but it is being put together in September, so the information is the latest available.

Details of the convention side trips were published in the January issue. Dan Orzano had sent more information on the side trips, but I edited them due to limited space. Format for the autocross was not decided until the weekend of the event.

It is impossible to cram six weeks worth of work into two weeks, so the best I can hope for is to trim a few days each issue. The long-term plan is to get back on schedule

within a year.

Some have asked why we don't just drop a few months cover date and extend everyone's subscription, but that means changing all renewal dates. The other problem is that we would then get a flood of calls asking about missing issues for a month in which none was published.

Patience -- perfection takes time.

T.W.

Blasting through Europe

I have been recently introduced to your club by a mutual Saab owner and I must admit that I was surprised there was such a club. Upon reflection, I felt relatively stupid for having not thought that one even existed - we have clubs for just about everything else, eh?

One rainy Sunday in mid 1986 while stationed in Southern Spain, my wife noted that the local Saab representative was having a test-drive of a 900 Turbo for those who desired. Being bored and enjoying a nice car, we took her up on the offer. I distinctly remember being told to get used to the power before we got daring (the rep didn't go with us - you won't see what a car will do if the owner is with you); I also remember making a snide remark about the awesome power of a four cylinder engine before driving off. Needless to say, we were pleasantly surprised and shocked at the amount of power in this car! Upon return (after a 30 minute spin) and getting out of the car, with shaking knees, I ordered my first Saab, a black 1986 900 Turbo EAG.

Being in the USN, I had to order the car between trips to ships at sea and pray that I would be "on the beach" when it arrived. The standard waiting period between ordering and delivery was 30 days. At the 30 day point, my car hadn't arrived due to a customs paperwork snag in Madrid, and I went to sea greatly disappointed. I did, however, take a poster of the car that I had ordered with me and spent the next three months staring at it and expounding on the virtues of such a car to all who would stand still long enough. The car arrived two days after I set sail and the Saab rep picked it up, got the insurance and tags taken care of and sent me a set of keys along with a polaroid. Upon return from sea, I hopped the first taxi, went to the rep's house and got my car. I roared off into the sunset, content. I took a speed run down to Gibraltar (through the mountains, of course) and was in motor heaven! Such a car!

Roads in Southern Spain are filled with obstacles ranging from slow Seats to a variety of animals, both domestic and farm. On 15 December 1986, while on the way to work in the early morning darkness, I happened upon a car upside down in the ditch. Out of the car crawled a fellow sailor, Joey, with whom I worked. I asked if he was all right and all he could say was, "What the hell did I hit?" I hit the bright lights and angled the car a bit and found a farm horse on the side of the road, obviously the object which Joey hit. He was relatively unscathed, but his poor Renault was trashed. I thanked my lucky stars that I had been late to work that morning, otherwise it would have been me and my brand-new Saab that would have hit Mr. Ed; the way I had been driving for the past few days would have resulted in an accident with a completely disintegrated horse and who-knows what kind of damage to my car as I would no doubt have hit the horse while deep into the TURBO ZONE. Shaken and vowing to slow down, I went on my way.

Things were uneventful that day and the next. On 16 December, I was heading home from work, preparing to fly back to the USA on the 17th to see my wife, when IT happened. I had originally left the base and stomped on the gas, but remembering the horse, I slowed down to a reasonable speed. At the last curve prior to my house, IT happened. I went into a sharp curve a little too fast; I let off the gas which caused the rear end to slide just a hair which in turn caused a great panic in my notwantingto-wreckabrandnewcar mind. *Hit the brakes! Downshift and turn in the direction of the skid! Wise advice for a rear-wheel drive car!* I did just that and the car responded like a cat and turned to the right. The car went off the road and hit the ditch nose-first. The nose stuck in the ditch, but the back of the car wasn't content. As it flipped nose-over, I was singing with the tape (Slow Ride by Foghat) and when things were said and done, I was hanging by my seatbelt with freshly plowed field dirt coming in my open sunroof. Whilst hanging upside down, I took a peek at the odometer - 623 miles. Six days. Boy, did I feel like a jerk. I hoped there was a gas leak, soon to be followed by an explosion so I wouldn't have to live this one down. I lit a smoke (still hanging upside down) and got my sunglasses. Joey's face appeared at my upside down window and he asked if I was all right. I got out and surveyed the damage. A bunch of people stopped by and we flipped the car back over

and I drove straight to my insurance company and told them I broke my car. Three months and four thousand claims later, I was back on the road in my perfectly repaired car. I have since learned how to properly handle a front wheel drive car, in particular, a Saab (get on it in the curves).

My wife and I drove that car to Southern Italy in the Summer of 1987 and sold it in late 1989 after 65,000 trouble-free miles. We bought a grey 1990 9000 Turbo in late 1989 and have had it since. I loved my 900, but I'm even more attached to my 9000! My dog and I drove from Southern Italy back to Southern Spain the Summer of 1990. We averaged 120 m.p.h. through Italy, Southern France and Northern Spain and enjoyed every minute! Doing the Italian Autopista at 135 m.p.h. is a dream: driving in Germany is fun, but Italy is more challenging. They go by rules in Germany; in Italy you make them up as you go.

We're hooked on these cars, as most of us are, and plan to sell this one and buy a '92 (the new ones have wiper on the headlights and I've never had a car with those).

People give me a hard time for not buying American and I tell them the same thing: as soon as Americans start building cars that are this safe, this comfortable, this economical, this fast, this roomy, this reliable, this downright well-designed, I'LL BUY ONE! Until then, it's Saab for my wife and I!

Ted Carwile
FPO AE

Cavalier attitude

The British magazine, *Automotor and Sport*, said in its June 2, 1992 issue that the upcoming 900 replacement is "based on the floorpan of the Vauxhall Cavalier" but that "three years of development has stretched any resemblance to the breaking point."

Recently, I drove two rental Vauxhall Cavaliers, a 1992 GL 2.0i 5 door with 700 miles on the odometer and a 1992 SRi 5 door. These models are twins of the Opel Vectra and do not resemble the U.S. market Chevrolet Cavalier.

This was a novel and interesting experience but should not substitute an actual test drive of the 900 replacement.

Both the GL 2.0i and SRi have a transverse mounted, 8 valve 2.0-liter injected engine on the right side of the engine compartment. Exterior size and width is roughly similar to the current 900. Interior room in the front and rear seats of

these sunroof equipped cars was good for this 6'1" driver. There is a medium sized floor hump and the fuse box had an empty slot for 4 wheel drive. The hatch lid does not have a hidden handle as the 900 does. Bumpers match the car's exterior but the color rubs off if contact is made during parking. Both Cavaliers were fitted with 15 inch wheels.

The G1 2.0i model was driven on the isle of Jersey (an independent island with ties to Britain). Narrow roads with adjacent stone walls and lack of any shoulder necessitates precise driving. Handling, in this respect, is good and an improvement over many American rental cars. Aggressive driving and fast cornering were prudently avoided. Quick lane changes, caused by accidently driving on the right (incorrect) side of the road did not result in excessive body roll.

Automotor and Sport reports that 25% of the part content for the 900 replacement are Saab parts, 25% are GM parts, and 50% are new parts.

I would opt for the GM parts in these two Vauxhalls for the removable rear headrest which are attached to the parcel shelf. However, I forgot to notice whether this shelf is removable as in the 900. Rubber mats in the glove compartment, center console, and passenger side storage bins are useful to reduce shifting of contents. Both Vauxhall's have rear wipers and leather shifter boots. *Automotor and Sport* notes that a British-made 2.5 V6 is planned for production. On the other hand, part of the beauty of a Saab is its 4 cylinder engine.

Saab "stove top" heater knobs are easier to turn than a linear arrangement. The Vauxhall's fan speed knob, in a similar fashion to Saab's seat heater thermostat, requires a thumb to operate and is prone to overshoot. Saab's lighting and green dashboard illumination appears better from an ergonomic standpoint. Saab's don't use a rod to support an open hood either.

In short, based on limited test experience, I found the two Vauxhall Cavaliers decent cars, but in need of further development to satisfy Saab drivers. In the U.S. market, I am not certain if they would fit American tastes, but I would consider them if I were looking for a car less expensive than a 900 and the cars were priced as such.

Jersey, an island of, perhaps, 60,000 people, has one Saab/Mitsubishi dealer with an interior showroom stocked with 3 Saabs. Some dealers also sell gasoline. In contrast,

I am not aware of any Saab dealers in the entire state of Arkansas or in Northern Louisiana. Therefore, the new 900 is not likely to be a heavy seller in that region!

Saabs are the only car I saw with a center brake light, probably a result of U.S. requirements. All cars in Jersey have fender mounted yellow turn signals. French Saabs, however, only have 2, not 5 brake lights, probably because of local regulations. I saw a 9000 with low front headlights during this trip. Its front corner turn signal only had a yellow light, not the additional white turning light that U.S. 9000 with taller lights have.

David Yee

Finely tuned

I was thumbing through the latest edition of "MUSICAL HERITAGE REVIEW" (Vol. 16, No. 7, 1992 Release 475) when I happened across a review of guitarist Julian Bream's CD release, "Baroque Guitar." Written by a William Zagorski, the second and third paragraphs seemed worth sharing with your readers, and Jack Ashcraft in particular.

"I have been fascinated by the guitar for years. In a world of ever increasing high-tech complexity, I find it miraculous that so much superb music can come from so uncomplicated and straightforward a device. Like the old SAAB 96 two-stroke engine (an extremely simple and elegant machine), the guitar has very few moving parts, discounting the tuning machines, only the vibrating strings. As I urge my clever automotive analogy further into the semantic thicket, I find a problem with that old SAAB motor of yesteryear and three pistons, three connecting rods, and a crankshaft, for a total of seven active components, all indulging in a violent orgy of reciprocation and rotational movement. Given this standard for a "moving part," the guitar, arguably, has none, the only active component that really counts is the finger of the player. Once a string is plucked, however, the whole apparatus becomes a moving part, and if the performer is gifted, a musically moving one as well."

I take exception with the "violent orgy of reciprocating and rotational movement," for if the 96 is properly tuned it will be every bit as much a moving experience as the guitar - and definitely a lot faster.

Should the guitar possibly be named as the preferred musical instrument for Saab owners?

Phil Hinde

FOREIGN AUTO PARTS

KYB GAS SHOCKS - \$26.09

99/900 MUFFLERS WITH
CONNECTOR PIPE - \$52.82

MANN OIL FILTERS - \$6.86

BALL JOINTS - \$27.43

REPCO METAL MASTER
BRAKE PADS - From \$22.21

N.G.K. SPARK PLUGS - \$1.94

HALOGEN BULBS

H9004 - \$9.95

AIR FILTERS,
99/900 Non-turbo - \$7.95

REBUILT STARTERS,
ALTERNATORS, CALIPERS,
BOSCH IGN. & F.I. PARTS
AND LOTS MORE!!!!
AT DISCOUNT PRICES

M/C AND VISA WELCOME
WE SHIP ANYWHERE

50 CANAL STREET
BRATTLEBORO, VT 05301
802/254-8729

U.S. TOLL-FREE
800-544-4600

Net, working

First, it can not be said enough that people like you make the difference. The work you do is the work of linking people with common interest together. You do it well, and we thank you for it. The alternative is that we grope around in an informational vacuum. You help to kindle the fire of enthusiasm that adds to the quality of life. So often we focus on the cars, but it is really the people sharing a common interest that we should look at. Many (the majority?) of the subscribers to the newsletter are not joiners of social clubs. I know I'm not. And although we choose not to join, we still enjoy communicating - on our own terms - with others of similar interests. The newsletter is an important link for those of us who are "doers" but not "joiners". Thanks Tim.

Wes Verkaart
& all the other members with similar feeling I am sure are out there.

Just in time

The sample edition that you sent me several months ago solved a parts problem. By obtaining the telephone numbers of

several dealers specializing in parts, I was able to find a part that had been "on national back order for several months." Why the local dealer was unable to do what I did is a mystery to me. I had the part sent to an independent shop that had worked on my 9000 previously and was back on the road without waiting for the dealer to produce.

Here is a tip that might save another Saab owner some grief: When one hears a noise similar to a power steering squeal, dry bearing, water pump noise, or fan belt slipping and it isn't, check the harmonic balancer pulley. There have been a number of failures on the pulley for both 900 and 9000 models in the Southwest. The pulley is made in several pieces and when the rubber insert starts to go, the noise begins. This noise can be intermittent but will get worse and eventually the pulley will come apart. Just looking at the pulley will not always disclose the problem. The replacement part has been re-designed and should have a much longer life.

Bob Tuttle, Jr.
Austin TX

Past issues

Boy, this old stuff is great!!! I learned how to build an inexpensive radiator for my 96 with an electric cooling fan, replace expensive dealer parts with generic stuff usually from junkyards, and do all kinds of diagnostic work. What a wealth of experience is in just the few back issues I have been able to glean since before I became a member in 1991.

One feature which I don't see anymore is the Nelson/Vanlandingham column, "News from Saab Clubs Around the World." In Jan. '89 it described a cooling system modification for V4's, promising details to come, but I never saw anything more of it, let alone the specs and diagrams which allow someone like me, not a line mechanic but simply eager to learn, to build interesting devices and continue to keep Jenny (my 96) purring through the '90's.

I refuse to complain about there being too many 9000 articles about skipping CD players, what executives are coming and going and the latest spoilers and such yuppie trinkets. It is my fault for not writing more and also the fault of other guys who are morally and professionally obligated to send in gems about older Saabs.

Robert Wagner
Brooklyn NY

P.S. Dick Grossman printed that the "only way GM will change is to line up those directors against a brick wall." However, GM may irrevocably change Saab, and the worst change may be in the production of a Saab that just can't be told apart from a GM. I'm seeing more and more 9000s up on the hook, dead on the road, than ever before...

Randy Nelson and John Vanlandingham stopped doing their column due to other commitments. We still swap newsletters with other Saab Clubs and would appreciate someone who could translate them and put the information gleaned into a column. We're looking for someone with a background in several languages, including Swedish, German, Norwegian, Austrian, and/or Hebrew (from the Saab Club of Israel).

The only thing at Saab that has changed under GM co-ownership is that the company has pared down and become more efficient under GM management. GM recognizes that Saab makes a unique product and tampering with it would dilute an already small market.

There have also been recent shakeups in the hierarchy at GM. As their market share dips, change seems inevitable.

T.W.

Plastic + Performance = Saab Fun

Plastic Front License Plate Brackets for 900s means an end to rust-frozen screws, no paint appearance problems and hassle-free installation of license plates. You won't find these in the Saab Accessories brochure, so buy 'em at Andrews. **\$25.00**

Bene-Vento Sunroof Wind Deflectors for 99 and 900 look as good as Saab OE and installation is a "breeze". Compare to Saab list at \$84.00. **\$45.00**

Headlight covers are available for almost all 900s and 9000s. Headlight replacement can be expensive (up to \$155 for one side!) and these attractive clear covers do a great job of protection. **\$49.50**

Performance means Group 6 products! We were so impressed with this stuff that we asked Frank at Group 6 Performance to make us his Upper Midwest distributor. Let us handle your performance needs with sport exhaust, stainless steel brake lines, timing control computers, air inlet kits and much more. Same low prices as Group 6. Information packet available.

ANDREWS

INC. OF PRINCETON
VISA/MASTERCARD ACCEPTED

Check us out on Used Parts, too.
All prices plus shipping

CALL TOLL FREE
1-800-882-7220

or 612 / 389-3805
(Fax#: 612-389-3875)
3558 Brickton Road
Princeton, MN 55371

Doktor Nio's SAAB Klinik

Submit your questions with as complete information on the problem as possible, also giving the year and model of SAAB. Problems of general interest will be answered here. No requests for personal replies please. Questions which would require modification of, or would defeat Federally required emissions systems will not be answered. For a proper diagnosis, it is recommended that you contact an authorized SAAB dealer or repair shop.

Send your questions to: SAAB KLINIK, 2416 London Road, Unit 900, Duluth, MN 55812-2221

I have a problem with the driver's power window switch. I recently repaired the power window switches according to the article in the January '92 issue of NINES. After I soldered the bulb, I found the two copper pieces inside this particular switch were not interchangeable, but I believe I have them installed correctly. I have tried bending the thin flat stainless piece between the two copper contacts because the fuse kept blowing. Now when the window reaches full height and I lift my finger from the switch, the window goes back down.

The top of the steering wheel in my '88 9000 Turbo with airbag system, blocks my view of the turn signal indicators and the top of the gauges. Is there any way to adjust the wheel to keep the airbag system, yet allow an unobstructed view of the display?

Frederick I Huganir
Carlisle PA

Obviously the contact arms are not installed properly in the window switch. Since you've been bending and moving the elements inside the switch, maybe the best thing to do is purchase a used switch from one of the "Nines" vendors in this issue.

It seems the seating position is higher in air bag equipped cars, so much higher in fact, that some people object to the lack of headroom in the later cars. I'm certain SAAB designers had a good reason for raising the seat in the air bag cars and I am not in a position to advise changing any aspect of the seat/fascia relationship.

This letter is concerning TECHNICAL TALK, "Gauges in the 900 Dash", Oct. '91. I have a '90 900S with the same gauges installed in the center console by the dealer when purchased. They all work well except that the outside temp. gauge tends to read about 3 degrees centigrade, (5 degrees fahrenheit) high in city driving. It is a little more accurate at highway speeds. The temp. measured at the sensor with a thermocouple compares favorably with the temp. indication on the gauge when the car is first started. I have a Volvo with an outside temp. gauge that is very accurate when compared with the broadcast temp. for the area in which I am driving. The

sensor on the Saab, when facing the front of the car, is mounted below the leading edge of the splash pan about five inches to the right of the towing eye. Is this the location that Stewart Bloom found in the directions for mounting the sensor?

Allan Headon
Mississauga Ontario

Try relocating the sensor higher in the front end, out of the windstream but away from the exhaust and radiator. It is apparently picking up the heat from the road surface which is why it is more accurate at speed.

I own two Saab 9000's, an '87 and an '89, normally aspirated and turbo-ed respectively. Both are automatics. The same curious symptoms on both. First, they both whine very loudly in first and second gear.

This is especially prevalent when the weather is warm, over 70 degrees. Secondly, they both have a huge howl that is apparently coming from the electric fuel pump in the tank. I've replaced one of them and that seemed to provide no relief. Once it gets over 70 degrees, it is almost impossible to hear the radio over the noise. The service dept. has looked at the pumps and doesn't seem to find much wrong. Third, and also related to weather, when it is warm and after I've driven the turbo, the car will not engage the started unless I hold the key over to the start position and rock the gear selector back and forth between neutral and park spots. It usually starts.

Jim Lauerman
Lincoln NE

The ZF automatic in the 9000 models should be quieter than some of the examples I have driven. The whine you refer to is not uncommon. Both transmissions are covered by an extended factory warranty, so rest easy.

I can't imagine a fuel pump so noisy that it drowns out the sound system. Be sure the pump is not bottomed in the tank and the fuel filter is properly isolated and not contacting the body anywhere.

The shifter has a start inhibitor/back up lamp switch attached to its linkage. Try removing and cleaning the switch with contact cleaner. If it is burnt, best replace it.

Questions regarding a 1985 900T 5 spd, 3dr:

1. What causes the corrosion on the positive battery cable end and battery post? The positive battery cable end corrodes and must be cleaned on a quarterly basis. When cleaning the cable end and battery post, a baking soda and water mixture is used to neutralize the acid and white grease is applied to the post and cable prior to reinstallation.
2. Does/should power steering fluid be replaced and at what time/mileage intervals?
3. Interior squeaks - what if any remedies are there? i.e. doors, (sunroof recently repaired for squeaks and rattles).
4. How often should Red Line transmission fluid be changed?

Jim Simpson
San Francisco CA

I'll probably create another hot debate on this one but I'm inclined to think the positive post is not sealed in the case as well as the negative is. Usually the corrosion is about the same on each post as gas seeps through past the posts. (A cold beer makes for a great corrosion buster, too!)

It can't hurt to change any operating fluid in any SAAB. It's the best preventative maintenance you can perform. There is a filter for Saginaw power steering systems available at your local autoparts store.

Removing squeaks begins with careful adjustment of the door strikers so the door solidly meets the body as when it was new. Use silicone spray on all the weather seals and the rubber strip on the sill. You can pull the hatch latch in tighter and move the rubber wedges located on either side of the body, bringing them up to meet the brackets on the hatch. A little Vaseline will quiet these bumpers.

In regard to changing the synthetic gearbox oil, fifteen thousand mile drain intervals would be fine but not absolutely necessary.

I am about to serve a two year tour in Saudi Arabia, cars not allowed. So, I want to store my '87 900S; I've had it since I picked

it up brand new in Sweden, and have really babied it. How would you recommend prepping the car for two years unattended storage? If you feel the car would suffer too much from such storage, I suppose I'll just sell it; need your recommendation. Thanks.

Kenny Whitley
Jacksonville AL

Instead of storing it, find someone you trust to drive the car once a week. Driving it long enough for the cooling system to cycle will keep wheel bearings and transmission hardware lubricated. Run the A/C system, and all the power assisted accessories such as the electric windows and mirrors. Lawn and garden shops sell fuel stabilizers to add to the gasoline so it doesn't go stale.

Personally, I would sell the '87 and purchase a 9000 CS when the tour is over!

After the warranty expires on my '90 900, I would like to find a dedicated Saab mechanic who can service my car regularly and keep it in peak shape indefinitely. Any suggestions for locating such a mechanic in my area?

The speedometer jiggles occasionally between 45-65 mph. The dealer said he'd have to replace the entire instrument, thus giving me a new odometer with an incorrect reading (000000). Is this really the only fix and will the odometer eventually fail if I just leave it alone?

Andy Pickett
Lincoln MA

The best way to find a good service shop for your SAAB is to ask other SAAB owners where they take their cars. Reputations are established by customer loyalty and if a particular shop is mentioned favorably numerous times, talk to the shop personnel and get acquainted.

It usually is the speedometer head that is at fault when the needle shakes at speed, however, I have yet to see the instrument fail completely because of this problem.

I own a '88 900T with A/T and 80,000 miles. It has never, even when new, accelerated well in warmer outside and underhood temp's. Acceleration and turbo boost progressively decline above 40 degrees. Above 80+ degrees and after warmed-up, it will hardly pull away from a stop for a few seconds before resuming speed. Other than this problem, the car runs great. The engine and systems checked out fine on an Allen Group Computer Test.

Perhaps unrelated but helpful in the diagnosis is that the exhaust pipe is very black and sooty. Could the problem be the NTC temp transmitter?

Gregory Perkins
Belleville IL

Without knowing how high speed performance is, I would guess the mixture is rich at low engine speeds. If the mixture were too rich, low speed conditions would hinder performance but high speed passing would be exhilarating. Test the NTC transmitter for proper resistance. Ensure fuel pressure is within spec under vacuum and pressure changes.

Another thought on the subject brings transmission shift points to mind. Could it be that 1st gear is not being engaged at low road speeds? Have the throttle cable adjustment checked with a pressure gauge on the transmission.

Finally, be sure the full throttle compressor cut-out switch functions properly, (I'm assuming if it's hot weather, you're running the A/C).

I recently bought a '72 95 Wagon. I am impressed with the craftsmanship, but the brakes seem to be a weak point (front calipers with top springs loose, therefore noisy, as well as retaining spring plate very thin).

Will retaining springs (over the counter) work as well on the rear brake pads/shoes?

It appears the front caliper has to be replaced because of the spring. Is there a place to send it for reconditioning?

In the May issue of NINES, neutering the freewheel is suggested. It would appear that the rationale is for preserving the longevity of the gearbox, as loose fitting freewheel control might cause problems. Correct assumption?

Arthur Cunningham
Oconomowoc WI

Parts for the 96 V4 cars are readily available from SAAB dealers or your local independent service shop. The caliper assemblies are \$182.00 each, p/n's 7873656 and 7873649. Look through the inventory of brake hardware at your local autoparts store and chances are good you'll find the brake shoe hardware you need. Still available from SAAB, the numbers are 7162233 for the shoe retaining springs and 7175037, 7192719 & 727 for the reaction springs.

The free-wheel control is necessary for 2

cycle SAABs when engine overrun could be hazardous to its health. Your V-4 will work just fine without free-wheeling, though if you reside in an area with lots of hills, coasting downhill with the engine idling can be economical albeit hard on brake linings.

Is there a kit that would remote mount the oil filter on a '86 Saab 9000T for access in the engine bay? I change my own oil (frequently in the air cooled Turbos) and would like to avoid the problems with hot exhaust and oil as well as restricted access to remove the filter from under the car.

Jan Hurd
Ridgefield CT

A remote filter would certainly ease routine changes but I don't know of a good location in the 9000 engine bay. Among the vendors here in NINES, SAS in Portland, Oregon comes to mind. They offer just the adapter or a complete kit. Their order line is 503-287-5204. Remember, the longer the run of hose, the more time it will take to gain optimum oil pressure, especially in cold weather.

I would like to know what 'Generic' type parts could be utilized for my '79 Saab 900S except the expensive Saab replacement parts. These parts would be such things as; alternators, starters, A/C compressors, etc.

Terry Parsons
San Jose CA

Generic? I think you'll find reasonable prices for the parts you mention from any one of the vendors here in NINES including those who sell used (road tested) parts. I know of a fellow who purchased an exchange GM R-4 A/C compressor from "Pep Boys" for only \$99.00 a couple years ago and it's still working in his '79 900 turbo.

In response to the idea of welding a washer to the clutch pedal, this works very well but still gives only the outer portions of the pin support. I have for many years repaired these pedals with an exhaust stud spacer p/n 9306812. This will support the entire pin and give much longer life to the repair.

Charlie Haigh
Fairfield VT

The "Golden Vice-Grip" award to you. A very ingenious fix that will definitely outlast the car itself!

PROFESSIONAL PERSPECTIVE

Congratulations! You are about to be introduced to a column which will reflect a professional's view of past, current and future concerns of you, the Saab owner.

We intend that this column will reflect our opinion, based upon our training and experience. "And what gives you the right to make these proclamations," you might ask? We are beginning our 20th year of business as an independent Saab repair shop. We are not huge, usually about ten people dedicated to servicing and selling only Saabs. Small enough to know most all of our customers well - well enough to know their concerns and joys of Saab ownership. We are ASE certified, PPG certified, etc. We are equipped to handle any and all problems.

That's the WHY of writing this to help address some of the many questions we are asked over and over year in and year out. For example: how do I choose a mechanic or body shop? What do all these certifications mean? What procedures are okay environmentally? Which repairs, parts and cars should I stay away from? Are high performance parts okay? What types of paint should be used on my car? What is four wheel alignment? How should rust be repaired? Does a 16-valve really fit a 99? What tires should I choose?

These concerns just scratch the surface. Again, our discussions of these and other topics will be based on our opinions. We live in the Upper Midwest where our problems may be different, but solutions should be relevant to everyone.

At the beginning we will not be answering any direct questions from the readers of Nines. If there are questions concerning the content of articles presented, we will answer those.

We were encouraged by the large number of people at the National Convention who went to the most technical of the Tech sessions. Education is the key to making wise and satisfying purchases. We will present reasons for knowing about your car and knowing who should maintain it and how. Restoration may be reflected as we see more and more interest in the vintage cars.

If you are interested in a certain type of Tech session at the next National Convention, you should let the Milwaukee Club know soon. They are already lining up speakers and topics for next August. They are well into planning the convention for you!

So much for introductions -- we look forward to expressing our "professional perspective" in the next issue.

Chuck Andrews
Andrews, Inc.
Princeton, MN



MTL® - Manual Transaxle Lubricant - SAE 80W GL-4

- Perfect synchro friction coefficient
- Eliminates notchy shifting
- Excellent shifting even when cold
- High-performance gear protection
- Non-corrosive to synchronizers

SI-1 Fuel Injector & Intake Valve Detergent

- One bottle cleans injectors to nearly 100% efficiency
- Cleans intake valve deposits
- Helps restore fuel efficiency
- Cleans emission control systems

Red Line Synthetic Oil Corporation

3450 Pacheco Blvd. Martinez, CA 94553
(800) 624-7958

Call or write for technical literature

NOKIA HAKKAPELIITA SNOW TIRES

185/65-15 T HAKKA 10
MOUNTED AND BALANCED
ON 900 OR 9000 STEEL RIMS
\$125.00

185/65-15 T NR 09 ON STEEL RIMS \$110.00

SPECIAL OCT 14 TO 19
NR09 HAKKA 10

185/65-15 \$45 \$60

165-15 \$47

REGULAR PRICE
185/65-15 T \$56 \$64

165-15 \$53

18 OTHER SIZES IN STOCK
TIRE STUDDING \$12

NEW NOKIA NRT ALL SEASON TIRE
185/65-15 \$63

1.7 & 1.85 -20 MAIN BEARINGS \$13

69-76 99 F TURN SIGNAL \$99PR

G & G SERVICE
4073 HUBERTUS RD
HUBERTUS, WI 53033
MASTERCARD & VISA
414-628-1716

165-15 ROLLSTER \$45

185/65-15 ROLLSTER \$51

NICHOLAS PELLEGRINO

FOREIGN MOTOR REPAIR

SALES **SAAB** SERVICE

282 ENFIELD MAIN RD. ITHACA, NY 14850

607/272-8259



295-6888

A & B SAAB SERVICE

3565 Pacific Hwy.
San Diego, California 92101
Factory Trained
Saab Technicians

SERVICE SUBJECTS

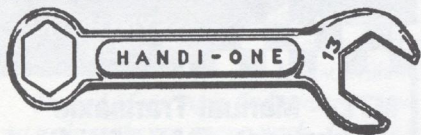

FROM SAAB

Radiator Fan Time-Delay Relay

Application: Certain 900s & 9000s
PSI 06/92-0218, Sec. 3/Pg. 23

On certain 900 and 9000 cars, the radiator fan may not shut off after the 10 minute cool down period and in some cases causes the battery to go dead. Therefore, production of the time-delay relay, P/N 95 63 339, for the radiator fan has been discontinued. It is superseded by the standard relay, P/N 85 22 310. On

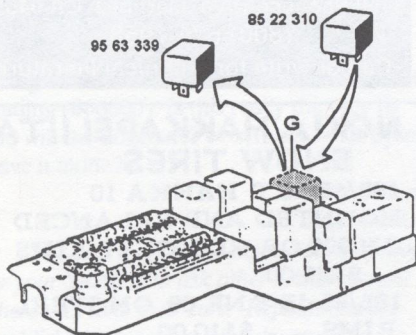

Figure 1 - Time-delay relay, radiator fan - 900 models

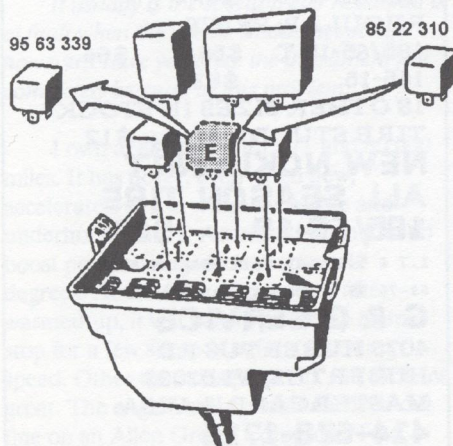

Figure 2 - Time-delay relay, radiator fan - 9000 models

1990-on 900 models and 1989-on 9000 models, these relays are fully interchangeable and the standard relay (P/N 85 22 310) should be installed as a replacement part, when needed.

Cars affected:

900 Models,	VIN M2500001- VIN M5010549- VIN M7019458-
9000 Models,	VIN M1020230-

Parts:

Standard Relay	85 22 310
----------------	-----------

Action:

For location of the time-delay relay, refer to Figure 1 for the 900 model and Figure 2 for the 9000 model.

Replace old time-delay relay with new standard relay, as needed. No modifications are required.

Possible Horn Malfunction

Application: 99 and 900 models
PSI 06/92-0221, Sec. 6/Pg. 2

A ground foil (P/N 89 40 645) in the steering column assembly, Figure 1, provides a ground between the upper needle bearing and the collapsible cage of the steering column

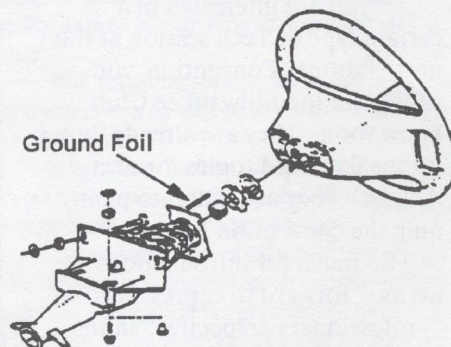

Figure 1 - Steering Column

by wrapping around the rubber bushing. If this ground foil is missing, the result may be a malfunctioning horn. There have been occasional complaints of this problem on 1988 900 models. Remedy by following the instructions below.

NOTE: This problem could occur in any 99 or non-airbag equipped 900 model.

Parts:

Ground Foil	89 40 645
-------------	-----------

Action:

1. Remove the steering wheel and the brass/plastic slip ring assembly to gain

Saab Parts and Service Information updates are provided to NINES as a courtesy to Saab owners by Daniel L. David, general manager parts and service, Saab Cars USA, Inc.

2. Loosen the collapsible cage and steering shaft universal joint. Remove the bearing.
3. Fold the ground foil in half, forming a "U", do not crease, as in Figure 2.

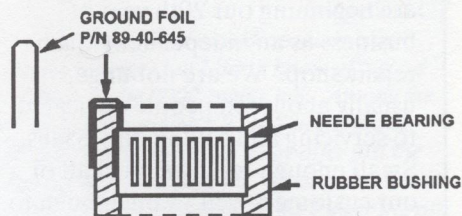

Figure 2 - Ground Foil Installation

4. Place the U-shaped ground foil over the end of the rubber bushing so that one half passes between the rubber bushing and outside of the bearing. The other half should run down the outside of the rubber bushing.
5. Reinstall the bearing. The end with the exposed ground foil should be inserted first so that it is pointed down away from the steering wheel.
6. Reassemble the steering column. Verify horn functions properly.

Adding a Starter Disable Relay

Application: 1991 Convertible models
PSI 06/92-0222, Sec. 19/Pg. 35

1991 900 Convertible models are factory-equipped with an Alpine alarm system that is similar to the accessory alarm offered for other 900 models, with the exception of the starter disable feature. The starter disable function can be added, however, for customers who desire this feature by installing the relay from the accessory kit.

Parts:

Starter disable relay	02 46 207
Torx screw	79 22 818
Connector pins (qty 2)	85 22 542

Installation Procedure:

1. Remove the bottom cushion for the rear seat.
2. Mount the starter disable relay, P/N 02 46 207, (figure 1) to the left of

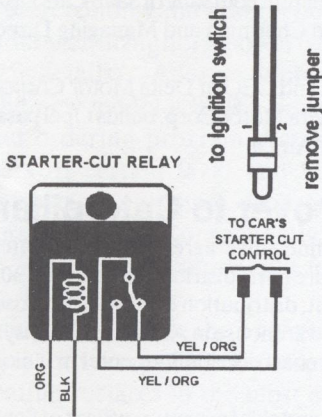

Figure 1.

center on the back side of the rear seat reinforcing bulkhead. Use the torx screw, P/N 79 22 818. If an existing hole is not present on the bulkhead, drill a 9/64 in. (3.5 mm) hole.

3. Connect the harness from the relay (orange and black wires) to the harness from the alarm module (orange and black wires).
4. Route the wiring harness (yellow with orange stripe) under the bulkhead panel to the left of the center tunnel.
5. Cut the terminals off these two wires and install the two male connector pins, P/N 85 22 542.
6. Locate the wiring harness leading from the ignition switch (yellow with red stripe). Disconnect the jumper plug from this harness and remove the pins from the jumper plug housing.
7. Insert the two new male plugs (installed in step 5) into the jumper plug housing and reconnect this plug with the harness to the ignition switch.
8. Reinstall the rear seat.

Testing:

The starter disable relay is a normally closed relay that is controlled by the alarm module. Unless opened by the module, the relay normally passes power to the starter. When the alarm is set off, the starter will be disabled for approximately 10 minutes, or until the alarm is deactivated by utilizing the transmitter button (alarm re-sets itself).

If the starter disable does not function, i.e. the starter continues to operate after the alarm has been set off, check:

- For ground to the black wire of the

relay.

- For power to the relay from the module through the orange wire (pos. 5 of the 12-pin connector).
 - If power and ground are present but the relay does not open, replace the relay.
- If the car does not start with the alarm disarmed, check for continuity between the two yellow/orange wires at the ignition switch. If continuity is found, the problem is elsewhere in the car. If there is no continuity, check the relay and wiring.

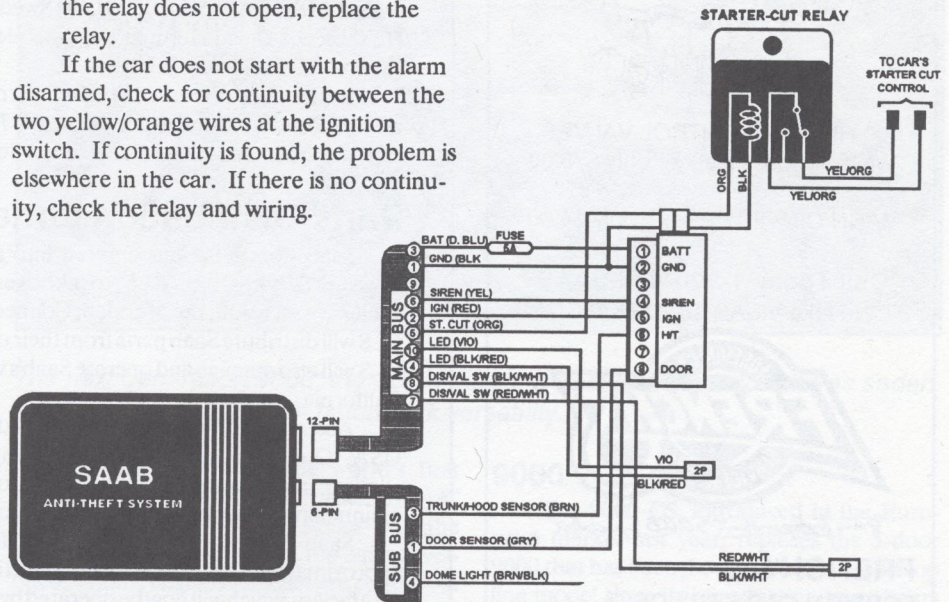

SAAB PARTS

AUTHORIZED SALES • SERVICE

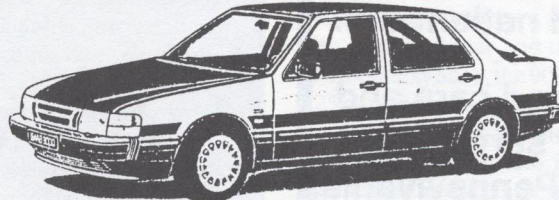

**NO SALES TAX • 10% DISCOUNT TO CLUB MEMBERS
SHIPPING ANYWHERE • KNOWLEDGEABLE PEOPLE
SAAB FACTORY TRAINED MASTER TECHNICIANS**

ALL MAJOR CREDIT CARDS ACCEPTED

Monte Shelton
MOTOR COMPANY

1638 WEST BURNSIDE • PORTLAND, OR • 503/224-3232

ROLLS ROYCE • JAGUAR • SAAB



900 HEATER CONTROL VALVES
(while supplies last) ... only \$75.00

MANN OIL FILTERS only \$4.00

Call Today 1-800-475-SAAB
We take VISA/MC/AMEX/DISC



Your Independent SAAB Specialist

FRENCH'S
FOREIGN CAR SERVICE
925 LUKE ST
IRVING (Home of the Cowboys!)
TEXAS 75061

DENNIS SWEENEY

ROAD TESTED
SAAB PARTS

Quality used and
rebuilt Saab parts,
shipped nationwide.

...

Saab used cars and
expert service for
Western Pennsylvania.

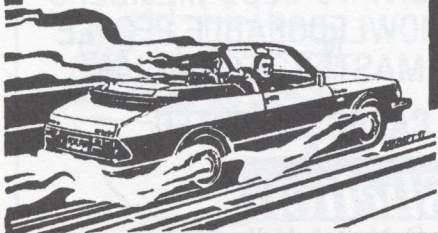

FAX 412-238-0099
PARTS 412-238-0900
RD 1, BOX 410, LIGONER, PA 15658

SAAB NEWS

New Pres/CEO at Saab Automobile AB

Keith Butler-Wheelhouse, 46, has been named President and Chief Executive Officer of Saab Automobile AB, the Swedish parent company of Saab Cars USA, Inc. He succeeds David Herman, who was elected Chairman and Managing Director of Adam Opel AG in early July.

Butler-Wheelhouse has been Chairman and CEO of Delta Motor Corporation in Port Elizabeth, South Africa since 1987. Delta Motor Corp. builds Opel passenger cars and Isuzu commercial vehicles in South Africa.

Parts Distribution turned over to Caterpillar

Saab Cars USA has entered into an innovative agreement with Caterpillar Logistics Services, Inc. (CLS) to take over spare parts distribution to Saab's 305 U.S. dealers. As a result, the Meriden, Connecticut, distribution center will be closed and CLS will distribute Saab parts from their own warehouse in Allentown, Pennsylvania. CLS will also manage and operate Saab's west coast distribution center in Union City, California.

According to William S. Kelly, president and chief executive officer of Saab Cars USA, "Our new alliance with CLS will improve Saab's long-term competitiveness by allowing us to invest greater capital into ongoing sales and marketing activities while maintaining a high level of dealer and customer service."

Saab opened its 136,000 square foot Meriden distribution center, located approximately 20 miles south of Connecticut's capital, Hartford, in 1987. The Union City facility, which will now be operated by CLS, was opened in 1990 and encompasses 104,000 square feet.

CLS is a subsidiary of Caterpillar Inc. with headquarters in Peoria, Illinois.

New Ad Campaign Stress es Performance and Responsibility

An aggressive new advertising campaign is being launched this fall to support the dynamic and unique combination of performance and responsibility that distinguishes Saab's 1993 model line.

In an era where the sheer joy of driving is often mutually exclusive of safety and environmental considerations -- and vice versa -- Saab's introductory campaign presents the ideal solution for discriminating drivers who want the best of both worlds.

Starring the restyled 9000 CS, a strong mix of television and print advertisements proves Saab's trend-setting commitment to the effortless blending of performance and responsibility features. The message, emphasized by kinetic, forceful images that draw the viewer into the driver's seat, highlights Saab's unparalleled leadership in important areas of safety, environmental and performance engineering, as well as the luxury importer's unwavering dedication to the fun of driving.

The new campaign, created by Angotti, Thomas, Hedge, debuted in late September with an initial sequence of spots to support the arrival of the 9000 CS in dealership showrooms. A sustaining product campaign is slated for the remainder of the model year, beginning in December.

The campaign also adopts a fresh international look that supports and complements Saab's pride in its Swedish heritage and pedigree. These graphic innovations are debuting in Saab's various market-specific advertising campaigns, as a result of a cooperative effort between major world markets.

At the same time, Saab's Swedish parent company, Saab Automobile AB, is launching a major worldwide campaign to underscore and promote its corporate image and brand position. Unveiled September 12, the focus of the campaign is to highlight Saab as a producer of world-class, premium automobiles. Scheduled for several international markets, the advertisements focus on Saab's corporate commitment to offering a unique combination of Swedish values and engineering heritage.

New for 1993

The Saab news for '93 includes the U.S. introduction of the 9000 CS and a new engine management system that improves fuel economy and lowers emissions without sacrificing horsepower (see page 16 for details). Another innovation for the new model year is a dealer option and ordering program that allows buyers of certain 9000 and 900 models to specify equipment packages to their personal tastes. Consequently, a new 9000 Turbo can be purchased for less than a '93 900 Turbo.

Saab buyers now have the opportunity to enjoy the luxury of a sunroof and leather seating surfaces in the most affordable 900, or appreciate the exhilaration of a turbocharged 9000 without the full range of deluxe features. Such preferences can be accommodated by their Saab dealer through the new option program.

Every 1993 Saab is backed by a 6 year/80,000 mile Major Systems Warranty, including bumper-to-bumper, no deductible coverage and Saab Roadside Assistance for 3 years/40,000 miles.

Environmentally friendly

Continually pressing ahead as an industry leader in the area of environmental concern, all 1993 9000s now include CFC-free air



The next generation 9000, the CS, is different front and rear. It features sedan styling and handling with hatchback versatility.

conditioning. Saab was the world's first automaker to publicly unveil such an A/C system. In addition, those 9000s with the turbocharged engine feature the Saab developed, Trionic engine management system -- a new engineering innovation that integrates ignition, fuel injection, and knock control systems for improved fuel economy and reduced exhaust emissions.

All 9000s now feature semi-metallic brake pads for longer life. Plastic parts within each Saab are now marked to facilitate proper recycling. 9000 models feature an interior ventilation filter that traps road dust, soot, and pollen, keeping occupants alert and attentive with a continuous flow of fresh air.

9000 - CS or CD

The 9000 CS, introduced in the European market last year, replaces the 5-door 9000 that has been the mainstay of Saab's top line model since its introduction seven years ago. The CS continues to provide the value and versatility of the familiar 5-door bodystyle, but with the refinement, comfort and styling

A new 9000 Turbo can be purchased for less than a '93 900 Turbo



Side impact and rollover protection has been improved in the 9000 CS

appeal of an elegant, yet understated, European performance sedan.

Distinguished by a unique new profile with front and rear end treatments that are unmistakably Saab, the 9000 CS benefits from a 25 percent improvement in structural rigidity, making one of the industry's safest cars even safer. In the process, road noise has been significantly reduced as well, while steering precision has been enhanced. Saab's integrated safety cage construction with front and rear crumple zones and an advanced system for side impact protection has been upgraded in the CS through the addition of a roll-bar structure behind the rear doors. The 9000 CS also features an optically-advanced, computer-designed headlight system with four separate lamps that illuminate low and high beams simultaneously for better nighttime visibility.

The 9000 CS is available with a variety of trim and equipment options, and may be speci-

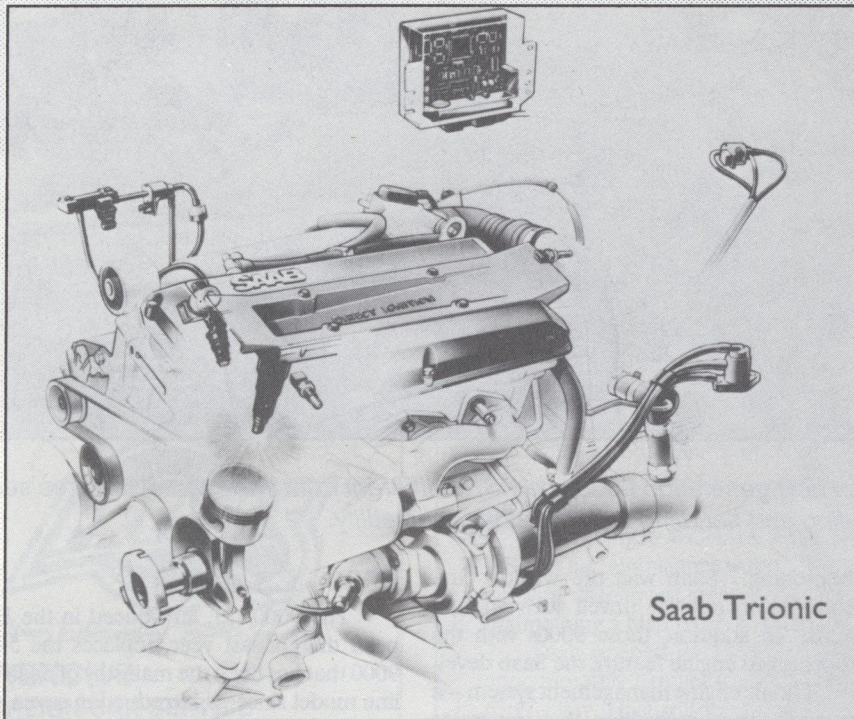

Saab Trionic

Saab Trionic System

The Trionic engine management system is another engineering advance pioneered by Saab. It automatically and instantly adjusts ignition, fuel injection and turbocharger boost pressure for optimal efficiency and performance as driving conditions change. The result is a vehicle that burns less fuel and produces fewer exhaust emissions, without any reduction in power output. Saab Trionic is standard on all turbocharged 1993 9000 models.

Controlled by a 32-bit microprocessor (provided by Luxor of Sweden) that can perform two million calculations per second -- the world's first automotive application for such a powerful unit -- Saab Trionic has the capability to meet today's and tomorrow's demands for cleaner-running, more powerful, fuel-efficient cars.

The Trionic system, which was totally developed by Saab, already has the capability of meeting proposed California emission levels for 1999, and future applications may control combustion efficiency even further. Not accustomed to settling for the norm, Saab joins an extremely elite group of automakers that have created their own engine management systems to

suit specific engineering demands.

An adaptive system, Saab Trionic constantly monitors itself and actually "learns" from varying operating conditions throughout the life of the engine, storing the information for use under similar conditions that may later occur. The fuel injection, ignition and boost pressure are then immediately and continually adjusted to suit changing engine parameters.

In place of a familiar air mass meter, the Saab Trionic system measures a pressure sensor located closer to the combustion chambers, along with temperature, load, and speed sensing capability to accurately determine the amount of fuel required by the engine. Each cylinder benefits from its own individually-controlled fuel injector, which sprays fuel into each chamber through two nozzles, one toward each intake valve in the four-valve head.

Injecting fuel into each cylinder according to firing sequence, the Trionic system features an extremely wide control range, allowing it to easily calibrate itself to alternative fuel specifications. In the interest of the environment, by virtue of its new Trionic system, Saab is today

preparing to accommodate the cleaner-burning methanol and ethanol fuels of tomorrow, and has already publicly unveiled a Saab 9000 prototype with multi-fuel capability.

The control of Saab's unique Direct Ignition (DI) system -- another Saab innovation previously added to the 9000 engine in 1990 -- is also incorporated into the Trionic logic. Saab DI is a capacitive ignition system with an individual coil for each cylinder, and no moving parts for improved ignition precision, durability, and starting performance. The integration of DI within Saab Trionic allows for even faster starting -- as soon as the key is activated, a small quantity of fuel is injected into each cylinder to facilitate ignition.

To supplement Saab's patented Automatic Performance Control (APC) system, the Trionic system monitors the combustion process and thus the onset of harmful knock through an innovative ionization measurement process. Since its landmark introduction in 1982, the APC system has relied solely on a knock sensor which could, under severe circumstances, be interrupted by mechanical noise interference. With Saab Trionic, a low voltage is now applied across the electrode gap of each spark plug after the combustion cycle. The need for a separate knock sensor is therefore eliminated.

The current flowing back from the plug to the Trionic control unit is measured and is a function of the number of ions formed. Careful monitoring can determine if incomplete combustion (knocking or misfire) has occurred, and fuel flow and/or turbocharger boost pressure can be adjusted accordingly. As a result, fuel consumption may be lowered and exhaust emissions reduced. Estimated EPA fuel economy values have subsequently increased by one mile per gallon (MPG) for 1993 -- from 17 to 18 on the City cycle for those turbocharged 9000 models with an automatic transmission, and 26 to 27 on the Highway cycle for manual transmission Turbo's.

The Saab Trionic system includes built-in diagnostic capability for improved serviceability. Committed to a strong, ongoing training program, Saab is ensuring that all U. S. dealers are thoroughly familiarized with and outfitted to service the new system.

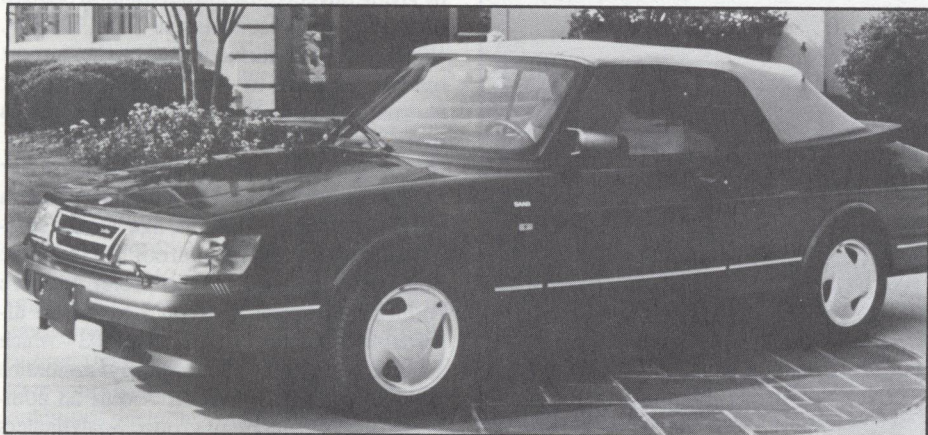

The 900 Turbo and 900S Convertibles continue with minimal changes for '93.

fied with Saab's efficient 150 hp, 2.3-liter naturally-aspirated engine or Saab's performance powerhouse -- the 200 hp, 2.3-liter Turbo. Both engines may be packaged with a manual, 5-speed transmission or optional 4-speed automatic. A fully-equipped version, designated 9000 CSE, is available with either engine configuration.

The 9000 CS is 3.7 inches longer than the 5-door model it replaces, yet the body weighs only 7.7 pounds more.

A 225 hp version of the 9000 CS, to be designated the Turbo S, may be introduced later in the model year, probably at Detroit's North American International Auto Show in January.

The 9000 CD sedan range continues for 1993, also available under the new dealer option and ordering system. Again, depending on specification level, the 4-door sedan will be badged either CD or CDE, regardless of which engine is included.

Two new colors will be available on 1993 9000s -- an eye-catching Imola Red and deep, rich Ruby Red. Ruby is mica-based and clear-coated for improved luster and durability. Carryover colors include Black, Cirrus White, Plantana Grey, Citrin Beige, Scarabe Green, Nocturne Blue and LeMans Blue, all with color-keyed bumpers.

An upgraded alarm system is standard equipment in every 9000 and also includes central locking with child-proof rear door locks and windows. A remote deck lid release is incorporated on the driver's door panel.

Saab 9000 models equipped with turbo-charged engines benefit from an improved differential assembly which helps curb torque steer during hard acceleration. On cars equipped with automatic transmissions, a shift lock has been incorporated which requires the driver to press the brake pedal prior to moving

the shift lever out of Park, and a revised anti-lock brake system offers improved pedal feel and serviceability.

With the lower hoodline, the headlamps have also been redesigned on the 9000CS. The optically-advanced lighting system has separate bulbs for high and low beam. New front turn-signal lamp clusters with side-guidance reversing lamps round out the re-design.

A sumptuous wool interior option, from one of Italy's leading fashion houses, has also been added to supplement pique upholstery or leather in any 1993 Saab 9000 model. The natural fiber of the wool creates an upholstery surface that "breathes," so seats remain cool in the summer and warm in the winter for improved comfort.

The 9000 CS starts at \$25,725, with the Turbo version beginning at \$29,720. The naturally-aspirated 9000 CD is priced beginning at \$24,825; the CD Turbo has a base price of \$28,820. The turbocharged CSE is the highest priced 9000 at \$35,055. (Prices are based on the 5-speed transmission, and do not include destination or dealer charges.)

The Familiar 900 is Back

The long running Saab 900 series returns for what may be its final year. Some automotive writers insist on referring to the model as "the aging 900", but 900 sales continue to be good, led by the popular convertible models.

As with the 9000 series, 1993 900 3-door hatchbacks and 4-door sedans benefit from the new dealer option and ordering system to accommodate a wider variety of personal tastes and budgets. The familiar "base model" designation has been dropped and the series now leads off with the 900S -- at, however, a 900-type, entry-level price, \$20,345 for the 3-door, \$20,960 for the 4-door model.

Engine options continue to be the 2.1-

For The Student Serious About Racing... And The Non-Racer Serious About Learning!

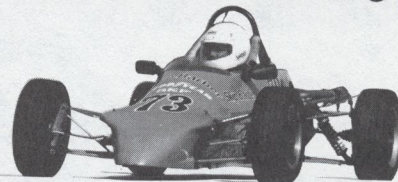

The Skip Barber Racing School has the most comprehensive ladder to success in the racing industry. We have programs for drivers of all speeds including:

- Introduction to Racing
- Three Day Competition Racing School
- Car Control Clinics
- Lapping Sessions
- Formula Ford Race Series



BMW Skip Barber
ADVANCED DRIVING SCHOOL

You'll explore the limits of vehicle dynamics and learn the art of car control from professional drivers. From behind the wheel of a high performance BMW 325i driving machine, the emphasis is on driving technique -- not racing. Our one and two day programs are guaranteed to produce better, safer drivers.

Over 20 Locations From Coast To Coast



SPECIAL OFFER FOR WINTER* PROGRAMS IN CALIFORNIA AND FLORIDA!

Book your Three Day Competition School or One- or Two-Day BMW Advanced Driving School by October 30, 1992 and receive a 10% Early Enrollment Discount!

*Offer valid on programs held between November 1, 1992 and February 28, 1993. Call or write today for our free 1992 course catalog and school dates

EASTERN HEADQUARTERS:

Skip Barber Racing School
Route 7 / Canaan, CT 06018 / (203) 824-0771

WESTERN HEADQUARTERS:

Skip Barber Racing School
Sears Point International Raceway
29355 Arnold Drive / Sonoma, CA 95476 / (707) 939-8000

Video Brochure and Gift Certificates Available.



The 900S replaces the base 900, but retains its predecessor's price position. The 4-door Turbo has been dropped for '93

liter in naturally-aspirated form, and 2.0-liter for turbocharged models. Manual 5-speed and automatic 3-speed transmissions may be specified for any 900.

The 1993 900S features pique upholstery, steel wheels with full, 16-spoke covers, air conditioning, and 150 watts of clear Saab sound from the standard modular audio system. Intelligently engineered and consistently

affordable, the 900S's long list of standard amenities make it an extremely solid value in today's crowded new car market which is characterized by fad and fancy.

Those looking to add a bit more elegance and exclusivity to the 900S may opt for a Saab luxury package that provides such customer conveniences as a power sunroof, cruise control, fog lamps, 15-spoke light alloy wheels, and leather seating surfaces. The price for this model is \$23,980 (for the hatchback with manual transmission), unchanged from its 1992 equivalent. All 900S models are powered by the 140 hp, 2.1 liter engine.

Rounding out the 900 model range is the 900 Turbo hatchback. Powered by Saab's lightweight and efficient 2.0-liter turbocharged engine, the 900 T offers 160 hp. The 4-door Turbo has been dropped for '93.

900S and 900 Turbo Convertibles remain part of the lineup for '93. The drop-top models led 900 sales this past summer and offer value as a fun car that is also safe and solid. The convertible top is available in three color choices -- black, blue and tan.

The two new exterior colors, Ruby Red and Imola Red, will also be available on 900s.

The all-new Saab 900 is expected to be revealed at the Frankfurt Auto Show in the fall of 1993.

Order your new Saab

More new-car shoppers than ever before will discover that a distinctive 1993 Saab 9000 or 900 is well within their reach, courtesy of Saab's new Dealer Option and Ordering Program. Introduced as a complement to Saab's prestigious 1993 model line, this innovative program addresses today's economic demands

by giving buyers the choice to tailor a Saab to their uniquely personal tastes -- and budgets. While other manufacturers in the import market continue to offer limited customer alternatives, Saab is bucking this trend with its new ordering program.

A Saab buyer can now indulge his or her preference for a turbocharged 9000 without a full range of luxury options, like leather seating surfaces and a glass sunroof. At the same time, those consumers who prefer creature comforts, but want them on Saab's most affordable 900 series, can specify a 900S -- which supersedes last year's Saab 900, but maintains the former's price position -- with an additional luxury equipment group. Saab dealers will assist shoppers in specifying the 9000 or 900 model that meets their individual needs.

The Saab dealer option and ordering program has kept the 1993 Saab 900S price with the luxury package at the same value-conscious level as last year, \$23,980 for the 3-door hatchback and \$24,595 for the 4-door sedan. The 9000 CDE with Turbo engine option actually benefits from a significant price reduction when comparably equipped to the 1992 9000 CD Turbo, down from \$37,615 in 1992 to \$35,745 in 1993.

To support the new program, Saab Cars USA, Inc., will maintain a variety of vehicle with the more popular option packages within its own, or dealer, stock. The more personal combinations will be special ordered, and will arrive at Saab dealers roughly eight weeks after the order is submitted by the dealer to Saab Cars USA, Inc. Greatest ordering latitude exists within the 9000 range, while the previously referenced luxury package applies to the 900S.

The Dealer Option and Ordering Program was facilitated by Saab's recent consolidation of port operations to Davisville, Rhode Island and Brunswick, Georgia. Utilizing an inland rail network known as Landbridge from Brunswick to serve Saab dealers in the western portion of the United States, the re-engineered distribution process provides increased product availability, flexibility, and delivery alternatives.

Whether fully-optional, or equipped to fit a more economy-minded budget, the 1993 Saabs include a model to suit most every comfort and financial consideration. In this value- and quality-conscious new car marketplace, Saab's Dealer Order and Option Program is yet another example of Saab's ability to increase the scope of its 9000 and 900 model lines for more car shoppers than ever before, without sacrificing the individuality for which the Swedish automaker is most known.

Specialty Car Care Products

ZYMÖL

ZYMÖL is a non-abrasive car care system, using all natural ingredients.

Cream Wax (For Light colors)	8oz.	\$35.00
Carbon Wax (For Dark colors)	8oz.	\$35.00
Saab Wax (For all Saabs)	8oz.	\$35.00
Japon Wax (Cars manufactured in Japan)	8oz.	\$35.00
H-D Cleanse (Use before Wax)	8oz.	\$15.00
Brite (Wheel cleaner)	8oz.	\$15.00
Strike (Removes oil & grease)	8oz.	\$20.00
Treat (Leather conditioner & treatment)	8oz.	\$15.00
Vinyl (Vinyl & Rubber trim)	8oz.	\$15.00
Clear (car wash)	8oz.	\$15.00
Fabrique (Cloth, fabric & convertible tops)	4 oz.	\$10.00

ZYMÖL Starter Kit - includes wax (specify), 8 oz. H-D Cleanse, 8 oz. Clear, Car Care Booklet, Towel, Applicator, Window Decal, Jacket Patch. \$75.00

ZYMÖL Complete Kit - A custom designed, hinged ABS case full of Zymöl products. \$200.00

Add \$5.00 for shipping

603-868-1730 FAX
1-800-245-2546 (USA only)
or 603-868-1732
24-hour answering machine

Specialty Car Care Products

34 Pinecrest Lane
Durham, New Hampshire 03824
Visa & MC

On board the CS

A chance to drive the 9000 CS? In Sweden? Sure! Sign me up!

So I joined about twenty other journalistic types for Saab's 1993 model intro in Sweden to bring you details of the newest variant of the Saab 9000.

Though we arrived in Trollhattan shortly after noon (Swedish time) we had several hours to clean up, tour, shop, or nap. Pre-dinner we boarded the bus for the short trip to the Saab Car Museum. I had visited the museum during a trip to Sweden five years before, but there were several new additions, including the GT750 donated by SAAB Club member Monty Tarr.

Media tours usually start off with talks by marketing and technical people, and this one was no different. Among the things learned: Saab will introduce at least one major innovation every year as part of a ten year plan. This year there are two major announcements -- the 9000CS for the U.S. market and the Trionic engine management system. There is also a new plan for Saab buyers in the U.S. to order a car with their choice of options. A "stripped" 9000 Turbo starts below \$30,000; \$6,000 less than last year's loaded 9000 Turbos.

The following morning we paired off, tossed our luggage into the trunks of a dozen CS's and headed east. A few of us took the opportunity of being in Trollhattan for brief tour of the Saab factory. Then it was off to Anderstorp Raceway, several hours drive away.

Anderstorp was the site of Formula One races in the 1970s. Jody Scheckter won his first F1 race there in a Tyrrell-Ford at the 1974 race, and in 1976, Scheckter and teammate Patrick Depailler swept the Swedish Grand Prix in the unique, six-wheel Tyrrell 34s. It was a popular venue for Swedes to cheer for their countrymen -- Ronnie Peterson, Bertil Roos, Gunnar Nilsson and Reine Wisell -- in action against the tops in auto racing.

The track is remarkably small, only two and a half miles long, and takes up very little real estate as it constantly loops back on itself. There is almost no infield as a result.

Today the track is best known for motorcycle racing, which is better suited to the tight, narrow road course. The back straight is part of an airport runway, more than a half mile long. The 200 hp 2.3-liter pushed the CS to 180 km/h on the straight, then anti-lock brakes helped keep the car from skidding off the corner. And it handles



remarkably well. People who love to drive will love this car.

On the open road it goes where it is pointed. There is virtually no torque steer, and the power prompted several automotive reporters to remark that the only reason for Saab to add a six cylinder engine to the lineup was to appease the market. Saab's turbo four is already better than most sixes!

One problem with the earlier 9000 was chassis flex. There have been some reports of earlier 9000s cracking due to the twisting torque on the body. The more heavily reinforced CS behaves more like the CD sedan. This also adds to the comfortable feel while cornering near the limit.

The following day we made several stops in Linköping, home of the Saab Aircraft division. The first was at the Swedish Air Force Museum, where examples of Saab military aircraft are on display, along with planes from many other countries that were used by the Swedes. Next was the Saab Civilian Aircraft factory, where our group took a walking tour to see the manufacture of the Saab 340 and 2000 turboprop airliners. The 340 is a popular regional airliner, seating 30 to 40 people. More than 300 are now in service, 180 in the U.S. The Saab 2000 is slightly larger version of the 340, with seating up to 58. The third Saab 2000 had flown for the first time only days before, and was undergoing final detailing in preparation for the Farnborough Air Show in Britain. We weren't allowed on board, but did get plenty of photos in the hangar.

The military branch of Saab aircraft

also made a presentation on the new JAS 39 Gripen (Griffin). After a short film and talk, we were treated to the real thing, as a test pilot put the Gripen through its paces, practicing for Farnborough. It was the highlight of the trip!

That evening we were treated to an interesting demonstration involving a '93 9000 CS and a 1950 SAAB 92. The 92 and 9000 were connected to emissions testers. After comparing the numbers, a hose was run from the 92's tailpipe to the 9000's intake. The emissions leapt on the 9000, but within 20 seconds the reading was back to normal. The Trionic system was acting as an air purifier, making the air that left its tailpipe cleaner than that which came in!

The final day saw us on a tour of the Saab engine factory in Sodertälje. There are actually two engine factories, which will soon be integrated into one. We toured the newer facility where the engines with balance shafts are produced, about 40 percent of the total production.

Upon arrival in Stockholm, we went to see the *Wasa*, a warship that sank in Stockholm harbor on its maiden voyage in 1628, and was raised from the harbor floor in 1961. It is still undergoing preservation in an environmentally controlled museum. On my previous trip to Stockholm the *Wasa* had been in a temporary drydock; it is now in its permanent home, though the cataloging of artifacts and work on displays continues.

Details on Saab Aircraft AB and the engine factory will be in upcoming issues of NINES.

Tim Winker

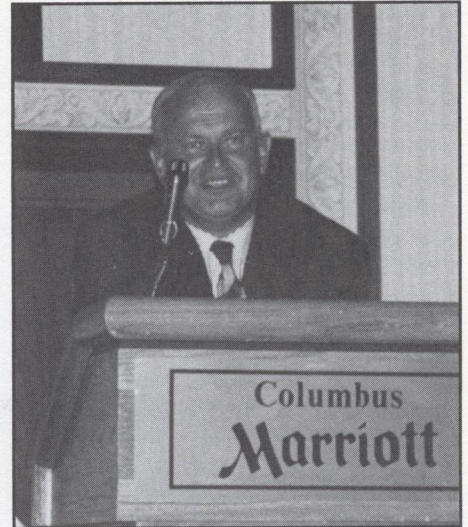

Images of the '92 National SAAB Owners Convention

Top left: One of the most popular Saabs at the convention was this 900 Limo, built by Dave and Penny Holtzinger of Lincolnway Sales & Service, Abbottstown, PA. The project was started in May and completed the week of the convention.

Above: This year's "Mystery Guest" from Saab was Bjorn Envall, Chief Designer (stylist) for Saab Automobile AB. Envall is only the second chief designer for Saab, having worked for Sixten Sason beginning in the mid-1960s and succeeding Sason as chief in 1969. He has contributed to or been the chief designer for the 99, 900, 9000 and the EV-1 concept car. Envall entertained attendees with a brief speech on future products from Saab and a displayed a drawing of the next 900.

Center left: Rare sunroof model 93F owned by Bud and Donna Allen of Maryland.

Bottom left: Todd Campisano's Concours winning 900 Turbo is a competitor in another arena as well. The rear hatch area is full of audio electronics.



Patty Egan, On Location Photography

Top: Our annual group photo. Can you find yourself in here?

Right: Gary Stottler's restored 99 Turbo took top honors among the 99s.

Below: Rally ace Erik Carlsson and Bill Jacobson of Sports Car Service talk Saabs and competition next to Bill's Sonett Super Sport.

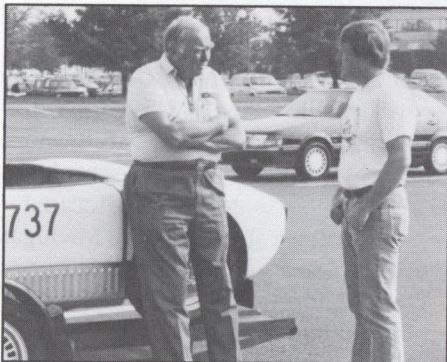
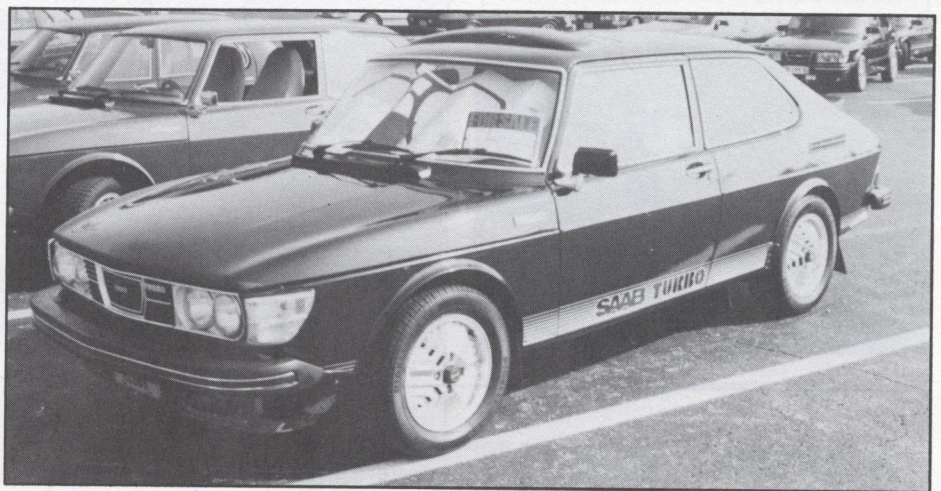

Lower left: Bud Clarke of J&B Imports in California won awards for Best 9000 and Longest Distance Traveled.

Right: A row of Saabs.

Lower right: Vintage Saab Racing Group brought this two-stroke Sonett and two Quantum Formula S race cars.

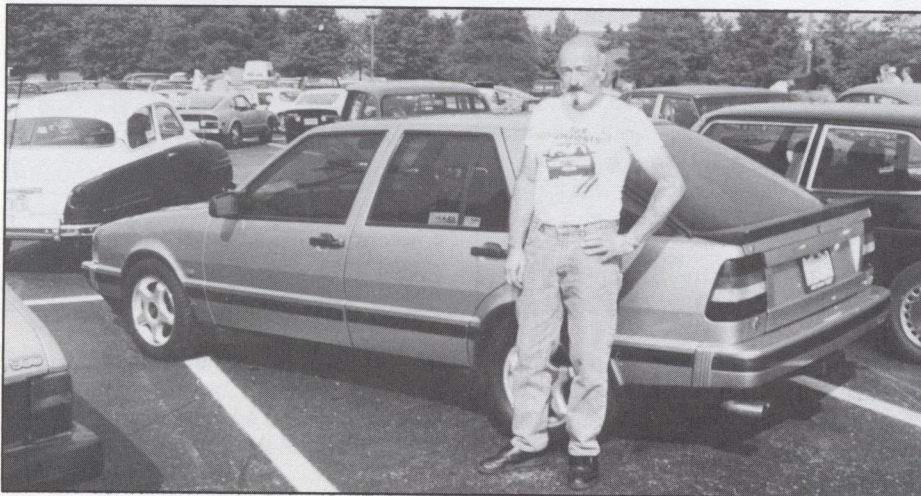



Patty Egan, On Location Photography



Alan Fein photo

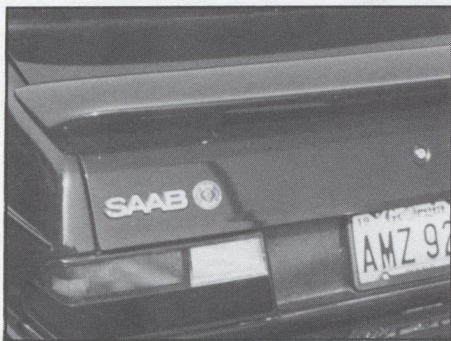

Above left: Mark School takes his race prepared Sonett III through the driving school.

Above right: Frank Freeman of Group 6 gives performance tips.

Left: Rear spoilers, Chris McPherson's 900 Turbo Convertible and Phil Neimann's 9000S.

Thanks to all of you who made the trip to Columbus to attend the 1992 National SAAB Owners Convention.

This year's event was one of the largest ever with nearly 450 people in attendance and almost 150 cars on site.

Special thanks must go to all the volunteers who assisted all weekend in making sure everything ran smoothly. Thanks Pete, Mary Kay, Dale, Shirley, Dave, Mike, Rich, Mom and Dad and assorted family members and friends.

Thanks also to Steve Rossi, Marie Warner, John Moss, Dan David, Erik Carlsson and Bjorn Envall from Saab for their assistance before, during and after the weekend.

Thanks to all speakers: Jack Ashcraft, Frank Freeman, Jack Lawrence, Rick Parr, Bill Jacobson and Willy Champion.

I want to thank our speakers, sponsors, advertisers, swap meet participants and other who donated prizes. Space does not permit me to mention all by name, but thanks to Tim Winker, NINES Editor; Bob Jack, Pirelli Tires; Alan Fein, Bosch; Chuck Bennet, Zymol; Jack Layne and Billy Edwards, Tracktime Driving Schools; Mid Ohio Imported Cars, Capital Star Service and One Stop SAAB.

I apologize if I have left anyone out but the brain cells finally gave out. See you in Milwaukee in '93.

Sincerely,
Dan Orzano
Convention Chairman
SAAB Club of Central Ohio

'93 Nat'l Convention in Wisc. Bolmeyer named Nat'l Coordinator

The Milwaukee SAAB Club will host the 1993 National SAAB Owners Convention in Kenosha, Wisconsin. The site is Carthage College, located on the western shore of Lake Michigan between Chicago and Milwaukee.

Ian Simpson and Pat Greer will co-chair the event, to be held the weekend of August 6-8.

Pat Bolmeyer, who co-chaired the 1988 National Convention in Wilmington, Delaware, has agreed to act as convention coordinator for the Saab Club. His job will be to assist convention chairmen in solving problems, and to maintain contacts with traditional convention speakers and with Saab Cars USA.

Zymol Concours Winners

92 thru 96

1st	Bruce Welch	1960 93F GT750
2nd	Bud & Donna Allen	1960 93F w/sunroof
3rd	Bob Abels	1964 96 850GT

Sonett

1st	Ed Lorenz	1974 Sonett III
2nd	Mark Jackson	1973 Sonett III
3rd	Richard Cobun	1969 Sonett V4

99

1st	Gary Stottler	1978 99 Turbo
2nd	Jess Jessup	1978 99L
3rd	Ben Fox	1974 99 EMS

900

1st	Todd Campisano	1986 900 Turbo
2nd	Pete Rechnitzer	1983 900 Turbo
3rd	Chris McPherson	1987 900T Convertible

9000

1st	Bud Clark	1987 9000 Turbo
2nd	John Matthews	1989 9000CD
3rd	Phil Neimann	1987 9000S

Best of Show: Bruce Welch, 1960 93F GT750

Peoples' Choice: Dave & Penny Holtzinger, 1985 900 Limousine

Longest distance traveled

Bud Clark, Torrance, California
Glen Ellis, Edmonton, Alberta

Pirelli Tire Rally results

Novice Class

1. Aaron Erickson / Maecile Easton	144
2. George & Wendy Basehore	312
3. Mark & Jeanine Jackson	347

Bringing Up the Rear (Highest score)

Jack Baxter, Sr. / Patricia Baxter 3035

Experienced Class

1. Barb Abrams / Gary Thomas	194
------------------------------	-----

Forty-five teams participated in the Pirelli Tire Rally. It was about 60 miles long, and was coordinated by the Ohio Valley Region, SCCA.

Official '92 Convention Souvenirs

At Special Close-Out Prices

Quantities Limited - Hurry!

T-Shirts: Yellow w/Blue logo, 50/50 cotton.

XL or XXL only \$6.00

Mugs: White ceramic w/ blue logo \$2.50

Caps: White cotton twill w/ blue logo \$4.00

Window stickers: 3" round yellow w/ blue logo,
for outside only \$.75

Please add \$4.00 for postage for any order (except stickers, add 25 cents). Send cash, check or money order in U.S. funds to:

SAAB Club of Central Ohio
2434 Dover Road
Columbus, Ohio 43209

BOB YATES

IMPORT CAR SPECIALISTS

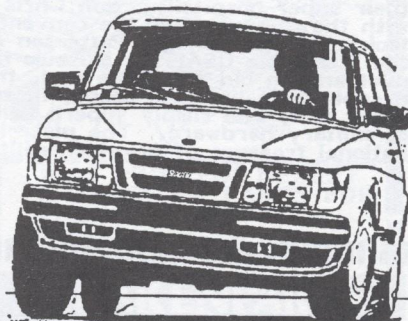

TOLL-FREE PARTS LINE
1-800-669-SAAB

Fax# 215/752-5614

Discount to SAAB Club members

Rt. 1 & I-95
Langhorne, PA 19047



Saab dignitaries participating in the Roundtable were (left to right): John Moss, service specialist; Dan David, manager of parts and service for Saab Cars; Steven Rossi, head of public relations in the U.S.; Saab's legendary rally ace, Erik Carlsson; and Bjorn Envall, Chief Designer for Saab Automobile AB.

photos by Tim Winker unless otherwise credited

SHIFTIN' GEARS

by Jack Ashcraft

DROPPING LEAVES

herald the onset of autumn & winter. It's a good time to have a look at the car for cooler months, with specific attention given to the cooling and braking systems. The coolant should be drained (the BLOCK as well as just the radiator) and refilled with a 50-50 mix of anti-freeze and water. This is also a good time to add a cooling system filter kit if you've been procrastinating on that one for a while.

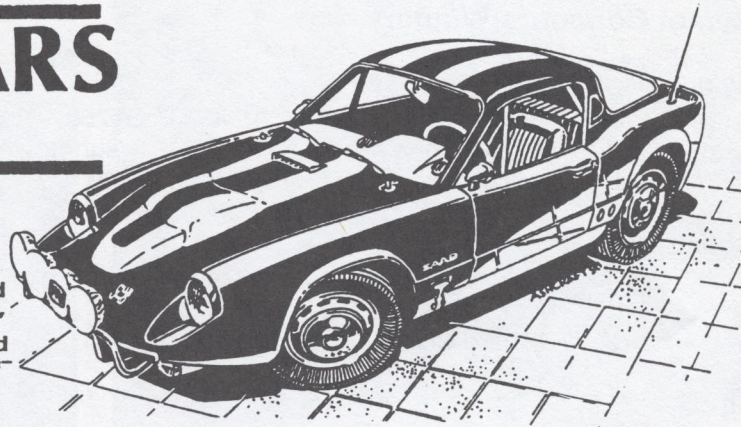

BRAKES

need attention, with a flush of the system, or at least a thorough bleeding to get a fair percentage of the old stuff out. Flushing is the BEST, as brake fluid tends to collect moisture, which turns into water and then finds its way to the lowest point in the brake system, where it sits and merrily corrodes the metal parts away. On Saab 95/96/97s the low point is the rear brake cylinders. Do yourself a favor--drain the old, nasty brake fluid out, refill and bleed the system. This once a year bit of trouble will repay you in brake system longevity down the road!

THE SAAB CONVENTION

Humidity or not, this year's national convention seemed to me to come off without a hitch. My hat's off to Dan Orzano and the rest of the Ohio Saab people who worked their tails off to make the convention happen. They did a heck of a job! Thanks again, all of you.

My thanks also to Richard & Sandy Cobun for their super hospitality. Son Chris and I stayed with the Cobuns after the convention and Rich took us over to Wright-Patterson AFB to visit the incredible USAF Air Museum there. To a pilot and an old Air Force man, the place is exceptionally broad in scope, incredible in its sheer size, and simply superb in its richness of military hardware. The place is truly a national treasure of American military history.

SAAB 95/96/97 SPECIAL TRANSMISSION DIP STICK TOOL

Ask your Saab Parts Counter man for Saab part number 7862444, the handy-dandy oil level dip stick for these transaxles. It works for two cycle

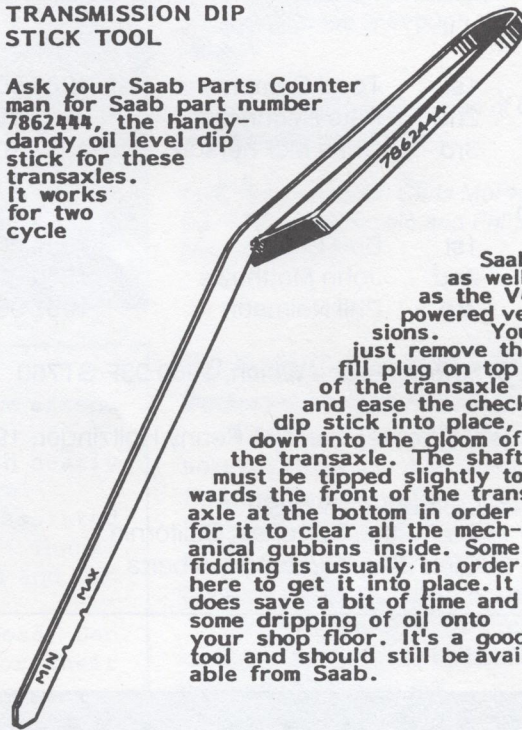

Saabs as well as the V4 powered versions. You just remove the fill plug on top of the transaxle and ease the check dip stick into place, down into the gloom of the transaxle. The shaft must be tipped slightly towards the front of the trans axle at the bottom in order for it to clear all the mechanical gubbins inside. Some fiddling is usually in order here to get it into place. It does save a bit of time and some dripping of oil onto your shop floor. It's a good tool and should still be available from Saab.



November 1, 1992 will mark the mailing of the PREMIER ISSUE of our new magazine dealing with Saabs, called THE SAAB JOURNAL, to our subscribers. This bi-monthly magazine, edited by yours truly, will be quite technical in nature, with a lot of how-to articles (illustrated--many of them step-by-step) covering Saabs from two strokes to 9000s. Happily, I won't be the only writer for this publication, with 7 others contributing articles, including some from overseas. It is NOT a newsletter, is NOT meant to be a competitor for NINES, but it IS quite technical and we think it will be a lot of fun to do. We also think it will be very useful for the Saab owner and we hope you will be a part of it.

SONETT FRAME PARTS

Another bullet-biting operation! All the measurements for the blueprints for these parts were made from a VERY straight, rust-free "roller" chassis/frame. Almost all the steel parts that make up a Sonett frame are now available from us.

Wherever possible we kept to the original design of the frame part, but bear in mind that we do not have a 40 ton press to make these parts and some of them are not exact duplicates of the originals. They WILL, however, FIT in the original places and look very close to original. In all cases we used 18 gauge or heavier cold roll sheet steel so the car should be stronger and stiffer than it was originally if you use these parts.

And Charlie decided sheet metal work was better than working for Kinney's!

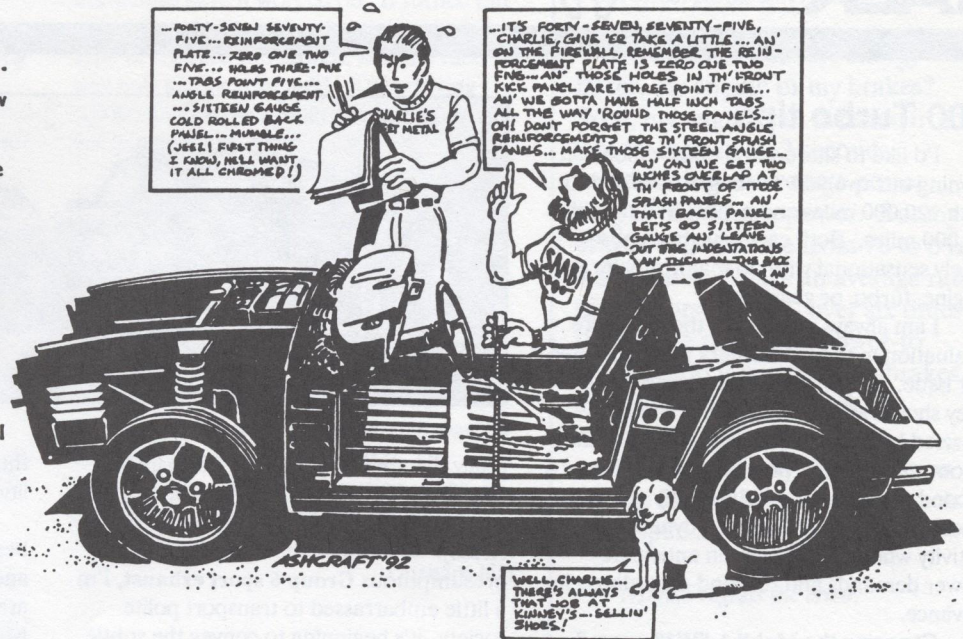

SONETT DOOR WINDOW SEALS

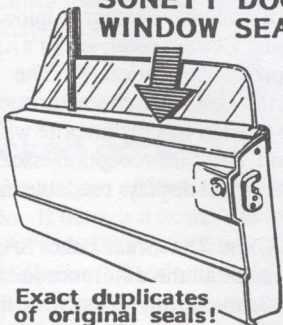

Exact duplicates of original seals!

Sonett II & V4 \$39 set of 2

Sonett III \$43 set of 2

SONETT FRAME SHEET METAL!!

New heavy gauge sheet steel pieces replace rust or accident damaged parts in your car.

Thicker in gauge, these parts will strengthen your car beyond that of the original part, at only a slight increase in weight. This is particularly apparent in the rocker panels & floor panels.

Write or call for details or send for our newest catalog with complete info on these sheet metal parts!

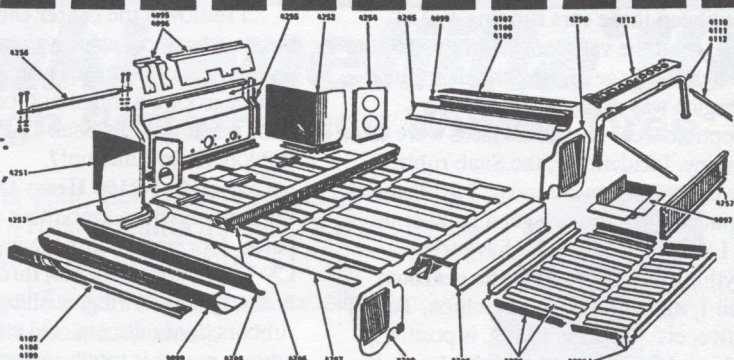

Bi-monthly magazine covers all Saab models, is written by working professionals in the Saab field. How-to's, trouble-shooting, high performance, restoration, Saab design, Tech-Line Q & A, historical perspective and much more! 1st issue 1 Nov 92. Subscribe NOW!

\$40.00 year

JUST PRINTED! NEWEST CATALOG OF PARTS FOR THE V4 SAABS!

SEND \$3.00

DRAKENPARTS™



JACK ASHCRAFT
AUTOMOTIVE DESIGN
2201 WOODLAWN DRIVE
MEDFORD, OR 97504
503-779-0731

4 PARTS

JACK ASHCRAFT
AUTOMOTIVE DESIGN
2201 Woodlawn Drive, Medford, OR 97504
503-779-0731

TECHNICAL TALK

Technical articles written by subscribers may recommend procedures or parts not approved by Saab-Scania of America, Inc. The SAAB Club and NINES cannot stand behind the correctness of information in these articles, but offers them based solely on the experiences of the writers.

900 Turbo tips

I'd like to share some observations on owning our **two 900 Turbos**: a 1985 4-door with 120,000 miles and a 1987 3-door with 68,000 miles. Both cars have been absolutely sensational with no major repairs to engine, turbo, or gearbox.

I am always puzzled by the mediocre evaluation in the Consumers Union annual car issue. For once, Lee Iacocca is right--they should stick to toasters. I am also puzzled by magazine reviewers who whine about turbo lag. It only takes a fraction of a second to downshift and instantly get all the boost you need. Driving is a dynamic activity where the driver can anticipate power demands and respond accordingly in advance.

Changing the **Mobil 1 5W30** every 3-4000 miles, is the most important thing that I do to keep these cars running well. I recently had the valve cover off the '85 due to a slight seepage around the distributor--the engine was magnificent with no perceptible wear and all surfaces were clean and shiny. Incidentally, the Saab rubber valve cover gaskets are lousy; I finally used Permatex Ultra Blue to get a good seal.

Like many Saabers, I have tried everything but Jolt Cola in the **gearbox**; Mobil 1, mineral oils, gearbox lube, TufOil additive, etc. Red Line MTL is positively the best; although, unlike Mobil 1, you have to shift very slowly during the first minute or two in very cold weather to avoid gear crunch, but once warm, the synchronization is superior (the guy who formulated MTL is known to dabble in the ways of the Saab).

Both cars have had the obligatory failure of the heater valve and water pump (thanks, NINES for the excellent Dec '88 article on heater valve repair).

Saab HQ has been very good and covered two items even after the warranty expired; the front bumper and the rear logo on the '87 delaminated.

There is a consensus among the 1985 Turbo owners in our Great Lakes Saab Club that you must install the **sway bars**. They are stock on all subsequent years and



really tighten everything up. I also added **Bilsteins** which were clearly calibrated for maximum *Sturm und Drang* (storm and stress). With those shocks and the slightly presumptuous **Group 6 sport exhaust**, I'm a little embarrassed to transport polite society--it's beginning to convey the subtle essence of a Metallica concert. It's great.

I removed the **center consoles**, installed base-car ashtrays, single unit audio and moved the sunroof switch to gain near-9000 legroom; it might not look as good, but since when would a Saab-O-Phile put fashion above function!?

I buy **Kel #105 Heavy Duty silicone** by the case and hose everything with it; rubber parts, door/hood/trunk hinges and gaskets, CV boots, door bottoms, throttle parts, hoses, ignition wiring, bushings, shock rubbers, seat rails, etc. Oil attracts dirt and lithium grease is totally unacceptable as it turns to a cakey mess in a year.

Regarding recent articles on **CV repair**: when securing the boots, get an official retainer ring clamping tool from a car parts store. If the correct 32mm retainer clamps aren't with your inner boot kit, then you can get them from a VW/Audi dealer.

The **dashpot** is an adjustment that is easy to overlook. I had not noticed the '85 dashpot getting a little tired with time and was amazed at the driveability improvement by dailing-in more damping. It significantly reduces transient loads on the powertrain and improves shifting.

I neutered those **annoying buzzers** under the back seat by jamming a toothpick between the coil core and armature; it shuts

them up, but the car still thinks they're on-line, so you don't lose your dome light, etc.

I've settled on **Michelin MXV's** as the best all-around tire after trying Pirelli P-6's and Michelin XGT-V's. Four wheel snows are absolutely essential here in northern Michigan. We tried front-only snows and Gislaveds and have enthusiastically settled on **Hakkapeliitta 10's** on all fours.

I have tried Sony, Pioneer, Alpine, Kenwood, and Clarion **receivers** (it's a long story) and prefer the Clarion (!). The Alpine had the best sonic characteristics, but overall, the Clarion was my favorite with decent sound, best AM reception, excellent noise rejection and displays readable in daylight.

NINES, and The Great Lakes SAAB Club, have made all the difference in owning our Saabs. Until recently, we lived over 60 miles from a reliable dealer, so it has been largely with their guidance that I have been able to assume all service work.

The utility of these cars continues to delight us. We have the retractable Saab hitch and have pulled an 18 foot boat hundreds of miles on several occasions by keeping it in 4th and drinking a lot of gas. The Thule roof system is also great; I've had it loaded with 4x4 lumber until there was a visible sag in the rack with no ill effects.

The 900 is an enduring classic (since 1979!) because it is a sports car, a safe car, a luxury car, a utility car, a snow car, a tow car, a durable car and an outrageously fun car!

Bob & Sarah Pierson
Williamsburg MI

Sonett Brake Hoses

I had to replace the brake hoses recently on my **Sonett II** (#187 - see cover, Apr 92). After eleven years of autocrossing, the ones that were on the car when I bought it started cracking. Here's what I found:

The local Saab dealer didn't list them anymore. BAP/GEON didn't list them any more (they did four years ago). Beck/Arnley listed rears only. Turns out what they list actually fit the front. They are the same as rear hoses for an MGB.

I did some cross-checking at BAP and found front hoses for Triumph TR4 and TR6 that are just fine for the rear of the Sonett, only a little longer. Check for rubbing because of the extra length. These can be modified as I described in the Nov '88 NINES to fit the front of the Sonett also.

Here are the part numbers:

	Front	Rear
Saab p/n	73-23-389	73-93-766
BAP/GEON or ITM	25-65204	25-65600
Beck/Arnley	073-0143	--- ? ---

You can probably get the cheapest price from a mail order British car parts place (check Hemmings Motor News), but I like supporting local shops that stock items on the shelf. The new interest in keeping old Limey roadsters alive will help us keep old Saabs running.

Nick Wilson
Colorado Springs CO

Wicked good

I now have 4000 miles on my '91 **9000 Turbo**. If there is a word to describe the car, it's "wicked!" (That would be as in "wickedly fast.") I did the first 1,500 miles on the factory P700's; then winter came. Four **Hakkapeliitta 10's** (195/65's) on Saab 15" wheels did the trick. These tires have made the New England winter easy to take. Driving up Interstate 93 to the White Mountains in marginal weather is a thrill.

It is my opinion that tactile feedback to the brake pedal from the ABS system is one of the great advantages of that technology: By slowly increasing the pressure on the brake pedal while slowing, one can judge the surface conditions by the point at which the pedal just starts to pulse. I have found myself "squeezing" the brake in this way all winter. When I feel the pulses on the pedal with only moderate pedal force, I know the surface is slippery and reduce speed accordingly.

Shep Siegel
Derry NH

200K Gearbox Repair

After I wrote my 200,000 mile report on my **1985 900 Turbo 16V** (Feb/Mar 92), I had to have the transmission repaired. The noise started at 203,000, and at 207,000 I decided to have it worked on. It turned out to be the big bearing on the pinion shaft. Half of the race was scored, as if the race was only half heat treated. After driving 5,000 miles on the rebuilt transmission, everything seems fine.

One note the technician passed along was that he normally has to use force to get the gears off the shaft. Mine slid off in his had with no effort. He wanted to know what I used in the transmission and how often I changed the oil. (Note from previous article: Mobil 1, Red Line MTL and gear oil from Trollhattan Motors, changed every 10 to 15,000 miles.)

I really enjoyed "Bluenote Highway" by Jonathan Bracken (Feb/Mar 92). He expressed in writing the sensation of the drive that I have experienced many times.

Larry Swanson
Durham NH

Correction

Due to an error in typing, a crucial phrase was missed in "Those are the Brakes" on page 30 of the June issue. The correct paragraph reads:

Which can convert energy faster, my engine or my brakes? Well, my engine can take me from 0 to 70 mph in 19.3 seconds, representing an average power output of 34 horsepower. But my brakes will take me from 70 to 0 in 4.3 seconds. That's an average rate of 209 horsepower - over six times the engine rate! The power-to-weight ratio is superior for brakes, too. The brakes can lock the wheels even in a worst-case scenario like a fully loaded car on a steep hill with the throttle stuck wide open....

NINES regrets the error.

Hakkapeliitta® 10

High Performance Winter Tires

- Year after year, European tire tests have rated Finland's **Hakkapeliitta** the ABSOLUTE BEST winter tire in the world.
- Directional Tread Pattern gives excellent control in snow and slush.
- Computer optimized design and extensive testing north of the Arctic Circle balance cornering, driving and braking grip.



Also available mounted and balanced on Saab original equipment steel wheels

Safety and Quality from Finland

Hakkapeliitta tires (pronounced hukka-pel-eeta) have an international reputation as the best winter tires available. Manufactured by Nokia Industries — one of the largest corporations in Scandinavia — Hakkapeliittas are a household word in most Northern European countries.

Also Available:

Yokohama A378 195/60HR-15 all season touring.
Michelin TRX 180/65HR-390 Sale, limited quantities.

For Your Vintage Saab:

Pirelli P3 (155SR-15)
Vredestein Sprint ST (155 SR-15),
Used 95/96 parts.

GREER ENTERPRISES

1810 E. Jarvis
Milwaukee, WI 53211
(414) 964-7463



New Products for Saabs Bentley 900 Manual

Service manuals, repair manuals, DIY manuals, whatever you want to call them, however helpful, they are not without their problems. The Chilton's manual for the 900 covers only common DIY repairs, and doesn't include the later 900s. The Haynes 900 manual is better, covers a broader range of repairs, is inexpensive and written for the do-it-yourselfer, but it only covers through the early 16-valve models. The Saab factory manuals for the 900 and 9000 are very expensive and take up a lot of shelf space. And there are no aftermarket manuals (yet) for the 9000.

Along comes Robert Bentley publishers, the folks who put out Official Service Manuals for Audi, Volkswagen, and BMW. At the behest of Saab Cars USA, they now offer an authorized service manual for the 16-valve 900s, covering 1985 through 1992 models. Similar manuals for 8-valve 900s and for 9000s are in the works.

The Bentley manual condenses the information in the multi-volume factory manual into a single inch-and-a-half thick, 626 page book. Much of it is through the use of smaller, though very readable,

typeface, smaller photos and diagrams, and the elimination of redundant instructions and pictures. The Bentley manual cleans up some of the systems diagrams, including wiring diagrams, making many more readable than in the factory manual. Photos used are the same as the factory book and are just as clear. Chapters are laid out using the same numbering system as the factory manuals. Updated procedures from Saab's Parts and Service Information (PSI) and Sales Training systems have already been incorporated, so the Bentley manual is more up to date than the factory manuals.

The project is a cooperative venture with Saab Cars USA to develop series of manuals on Saabs. Carlton Dingman of Saab approached Bentley with the idea of putting out a single volume that would replace all the bound volumes, something that could be used by DIYers and professional technicians alike.

Bentley was allowed free reign of Saab's technical material and use of the corporate logo, and was given the blessing of "official" manual. Saab employees, including John Moss, Dan David, and Bob Popiel helped Bentley editors Charles Burke and John Lamb over the rough spots.

The Bentley 900 16-valve manual takes advantage of the latest desktop publishing technology. All of the text was entered into a computer, and diagrams and line art were scanned and saved on computer disk, then cleaned up using a computer graphics program. Photos were added later by traditional half-tone methods, but, with improvements in computer scanning technology, photos will be scanned for future manuals. Layout for the manual was done on computer, then sent to the printing company on disk for the final printing.

The only complaint one might have is the price, \$49.95 suggested retail. Though the initial cost may seem high for a book, it is still less than an hour or two of shop time at most Saab repair shops. And the information contained will likely save the backyard Saab mechanic hundreds of dollars by walking him (or her) through the steps of a tough job, or allowing the Saab owner to brush up on a problem so it can be intelligently discussed with the service writer at a repair facility.

The 900 8-valve book is due to be released in November, while the manual for the Saab 9000 is scheduled for printing in the Spring of 1993.

Tim Winker

Denim seat covers

An oft requested accessory for Saabs (or any car for that matter) is seat covers. Let's say little Jimmy has spilled Faygo Red Pop on your velour seats, or some careless relative has burned a hole with errant cigarette ash, or the fabric has simply worn out or faded from hundreds of thousands of miles of Saab driving pleasure. Or, as in my case, you have a dog that one day decides to find out if there's something buried under the rear seat cushion.

Saab takes time to engineer their seats for comfort (unlike most manufacturers who seem to just pick a generic pattern then take great pains at making the covering match the rest of the interior), so the "one-size-fits-all" seat covers at your local Target or Wal-Mart store won't fit a Saab seat. Jean Seat International (phone 1-800-881-0509 or 305-963-4989) does provide custom fit seat covers for Saabs.

Since my primary concern was the rear seat, I ordered only the rear cover for my 1985 900 Turbo. Jean Seat has taken the time to measure and fit the seat cushions, including a cutout for the rear armrest. The entire rear seat kit for my Turbo consisted of five pieces -- covers for the back and seat cushions, the armrest, and two head restraints. The cut on all pieces is good, matching the contours of the cushions well.

Unfortunately, there are compromises. The elastic loops to secure the covers are haphazard and don't have anything to attach to, nor are they quite long enough to hook together. Button-hole slots around the head restraints would be nice so there would be no bunching.

There is one area that is downright dangerous and should be corrected. The strap to release the seat cushion is covered and inaccessible, as is the seat cushion latch on the underside of the cushion. The seat cover interferes with the latching mechanism. Again, button-hole slots could take care of these areas. Saab dropped their accessory rear seat covers several years ago because the lack of an opening for the seat latch could cause the bottom cushion to slide forward in a quick stop. Since this is a matter of safety, Jean Seat really should change their pattern to accommodate the seat latch and release strap.

The armrest cover fits well, with a metal snap at the back to hold everything in place. The hole in the back cushion is only that, consequently there is a gap around the

Exclusive

SAAB

Parts Center

*The area's most extensive
inventory at
competitive discounts*

(215) 886-8660

Free delivery locally
or Standard UPS

SAAB 

 **VICTOR**

Exclusively SAAB since 1958
1125-35 Easton Road • Abington, PA 19001
Facsimile (215) 572-5030

armrest opening. If you don't normally use the rear armrest, you might prefer to order the back piece without the armrest option.

A system using hook-and-loop (Velcro) fasteners might well cure several of the problem areas listed. The *hook* piece could be sewn to the cover material to easily attach to the carpet on the back of the back cushion, and small carpet, or *loop*, sections could be glued or stapled to the bottom of the seat cushion for stronger attachment.

The problem areas are minor annoyances when you consider the overall quality of the product. All of Jean Seat International's seat covers are, as the name implies, made of denim, which makes them easily washable. They come in a variety of colors and are available with a SAAB logo stitched into the back cushion, or your choice of monogram for a slight additional cost.

99 owners will appreciate that Jean Seat International makes seat covers for their Saabs, as well as for the 900 and 9000 models.

Tim Winker

Rock Bottom Saab Part Prices!!!

This Month's Specials

(good thru 11/15/92)

"Soccer ball" alloy wheels (used)	\$45.00 ea
Water Pump (8 vlv.) (GMB)	\$27.50
Warmup Regulator (rebuilt)	\$135.00
Automatic Idle Control Valve (16 vlv.)	\$118.00
Thermostat (Turbo, 82°C)	\$9.25
Shock absorbers (Sachs, Boge)	\$47.50 ea
Electric Antenna Masts w/ gear drive	\$24.95
Hatchback Lift (shock) Assist	\$32.95 ea
Power Steering Rack - 10 year Guarantee!	\$195.00
Fuel Tank Sender Unit	\$35.95
Engine Mounts (non-hydraulic)	\$26.50
8-valve cylinder heads (Turbo), rebuilt	\$365.00

Mastercard / Visa

Call or write for complete catalog!

900 Club

P.O. Box 410634

San Francisco, California 94141

Call Toll Free

1-800-377-2582

"YOUR PARTS CONNECTION" -- IMPORTERS OF TOP QUALITY PARTS

M-F 7:30 am - Orders Only
5:30 pm M.T. \$25.00 Minimum
1-800-999-1820
MC/Visa/Amex/Discover

IMPORT MOTOR PARTS

110 WEST 12TH ST., PUEBLO, CO 81003
** Same Day Shipping **

Information & Sat. 9:00 am -
Technical Help 1:00 pm M.T.
1-719-542-7025
FAX 1-719-542-7026

ALTERNATORS
BILSTEIN
BOSCH
CLUTCHES

SUSPENSION TECHNIQUES
STARTERS
REPCO

Special on remanufactured parts -- our prices are falling.

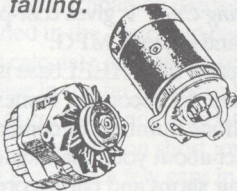

- Great prices on Bosch quality
- Remanufactured Starters and Alternators
- Designed to fit most imported vehicles
- One-year, unlimited mileage warranties

Don't wait until your starter won't crank, and your alternator won't charge. Call us today.

ALTERNATORS	
85-86 900T, 86 9000 Turbo	236.95
78-83 Turbo & 81-83 900s	169.95
STARTERS	
75-84 99,900 & Turbos	102.95
69-73 95, 96 & 71-74 Sonett	86.95

BOSCH

Clean up your act.

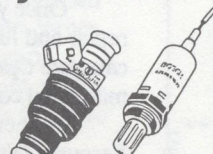

- Fuel-injection components for Import vehicles
- Bosch Oxygen Sensors improve fuel efficiency and keep emissions in check

Keep your vehicle running clean. We carry genuine Bosch Oxygen Sensors, made by the company that introduced the oxygen sensor.

FUEL PUMPS	
82-86 900, 82-84 Turbo	225.06
75-81 99, 900 & Turbo	212.51
WARM-UP REGULATORS	
76-80 99, 900 Non Tbo	85.86
78-80 All Tbos.	106.22
OXYGEN SENSORS	
77-86 1 Wire	39.95
INJECTORS	
81-86 900 All 8 Valve	25.95

BOSCH

KONI SHOCKS	
Adjustable Shock (most Saabs)	58.95 ea
BILSTEIN SHOCKS	
HD Setting for 900 8 valves	66.85 ea
MISCELLANEOUS ITEMS	
Wind Deflector 900s	47.50
Clutch Disc 99,900 4 sp NT	44.45
Clutch Cover 99,900 NonT	49.95
Clutch Slave Cyl 76-85	79.95
Brake Disc 69-74 99 F & R	36.95
Front Calliper 75-85 All	199.80
Frt Brake Rotor 81on 900	39.95
Clutch Master Cyl 79-85	79.95
Master Cyl 75-85 All	141.65
Ball Joints 99, 900	26.95
900 Heater Control Valve	93.95

KYB
Gas-a-just
Shock Absorbers
\$23.95

RADIATORS & WATER PUMPS	
Radiator 1977-80 99s	179.00
Radiator 79on 900s	179.95
Radiator 79on 900 Tbo	187.95
Pump 75-76 99 12 Cog	69.95
Pump 77-80 99, 900 (Kit)	79.95
Pump 69-76 99 (Kit)	35.95
Radiator 69-76 99s	209.95
Pump 67-74 95, 96, Sonett	33.95
Radiator 78-80 99 Tbo	189.95
Pump 81-88 900 8 Valves	36.95
Radiator 86on 9000 5sp	297.00
POWER STEERING RACKS	
79&on 900s (Short)	189.95
79&on 900s (Long Rack)	239.95
REPCO METALMASTER PADS	
76&on 99,900s (Rear)	24.65
99,900 Front Brake Pads	24.65

Tune-up special.



- Bosch Spark Plug Wire Sets feature premium quality
- Custom tailored
- Fit most Imports — European or Japanese
- Lifetime warranty

Tune up with the best - A Bosch Spark Plug Wire Set. Call us today.

Wires 81-87 900,900 Turbos	12.95
Wires 85-88 900 16V	42.95

BOSCH

Tune-up prescription.

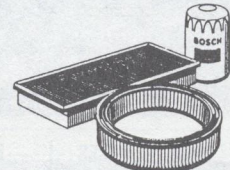

- Bosch Filters keep your vehicle running smooth and clean
- Improve mileage and performance
- Available in sizes to fit your Import car, van or truck

Tune up with the best - Bosch Oil, Fuel and Air Filters. Call us today.

Fuel 5/85-86 900, 16V,&Tbo	16.58
Oil 67-88 Saab All	3.77
Air 75-86 2.0 exc 16V	5.50
Air 85-88 16V	7.19

BOSCH

ENGINE PARTS

FILTERS

FUEL INJECTION

IGNITION

KONI

RADIATORS

Computerize your record keeping with WHEELbase

When was the last time you had the transmission lube changed on your Saab? What year was the battery last replaced? Was it last year or the year before that the radiator was flushed and new coolant put in? You probably have that information written down somewhere, but is it easily accessible?

Saab Club member Bob Pierson has come up with an easy solution. Put it all into your home computer. WHEELbase (tm) Vehicle Maintenance Manager allows you to record all of your maintenance data in an easily accessible format.

WHEELbase requires an IBM-style computer with 640K RAM running MS-DOS 3.0 or higher. Installation is painless as prompts help you through the process. The program takes up less than 400K bytes on a hard drive. I tried to set it up so it would start from Windows, but it won't recognize any vehicle files that may have been saved. It works better to start from the DOS prompt to access the vehicle files.

Though there is a short (24 page) User Manual included, on screen prompts make it unnecessary after the first run through. When you first use WHEELbase, you will probably want to backdate the records from an existing vehicle. Enter the initial mileage (the mileage from which you want to begin your records) to act as a starting point for calculating total costs.

WHEELbase		1985 Saab 900 Turbo		120,155 Miles		JUNE 11, 1992	
Service Item List							
SERVICE ITEM	LAST		INTERVAL		NEXT		
	Date	Miles	Months	Miles	Date	Miles	
Air Filter	06/15/91	103,500	12	12,000	06/15/92	115,500	
Battery	12/18/89	79,000	48	0	12/18/93	---	
Belts	07/02/89	61,244	24	50,000	07/02/91	111,244	
Brake Pads	09/05/91	115,500	0	15,000	/ /	130,500	
Coolant	11/22/91	116,703	12	10,000	11/22/92	126,703	
Exhaust System	03/29/91	110,271	30	50,000	09/29/93	160,271	
Fluids	11/05/91	116,419	12	12,000	11/05/92	128,419	
Fuel Filter	06/30/90	90,430	24	24,000	06/30/92	114,430	
Ignition System	06/30/90	91,140	36	60,000	06/30/93	151,140	
Insurance/Plates	11/16/91	107,455	0	0	/ /	---	
Miscellaneous	09/05/91	115,500	0	0	/ /	---	
O2 Sensor	04/11/89	64,988	30	60,000	10/11/91	124,988	
Oil/Oil Filter	11/05/91	116,419	3	3,000	02/05/92	119,419	
Shocks	11/02/89	71,030	36	60,000	11/02/92	131,030	
Spark Plugs	12/30/89	79,400	10	36,000	06/30/91	115,400	
Tires	06/02/92	119,504	0	30,000	/ /	149,504	
Transmission Fluid	12/27/90	102,418	36	50,000	12/27/93	152,418	

(ESC) Main Menu—(ENTER) show Log MORE—scroll

F1-HELP F2-ADD ITEM F3-DELETE ITEM F4-INTERVAL F5-FUEL F6-DUE F7-PRINT F8-COST

The Service Item list and Intervals can be modified to suit the wants of the vehicle owner.

When adding a vehicle to the database, WHEELbase will create a generic Service Item list that includes standard replacements such as filters, oil changes, coolant, exhaust, brakes and battery. You can alter the list to include other items, such as *Accessories, Insurance, or License Plates*. You can also change the intervals for service items to fit recommendations of different manufacturers or your own preferences.

Based on the mileage and date intervals, WHEELbase will let you know

when a particular service is due, or if it is overdue. This will allow you to make appointments for scheduled maintenance several weeks in advance. It also helps to remind you everything that might need to be done so you can inform the repair shop when you have the car in for service.

Each Service Item also has its own log to record every time that service is performed. There is also a *fuel log* which calculates MPG for each fillup. Every log also has a section for cost and for notes about a service performed. Under the fuel log, it can be used to note if a different octane fuel was used or if an additive was included on a particular tankful.

Once you have entered all of your repair and fuel records, WHEELbase can calculate *Operating Cost*. It gives cost-per-mile, total cost, and average MPG.

Another section of WHEELbase is the *Resource Directory*, for recording names, addresses and phone numbers of companies you might contact about your car, including dealerships, repair shops and parts stores, including mail order places.

The SAAB Club was given an early version of the program to test, and when there were any problems, Bob was able to correct them, usually on the first phone call or fax message.

WHEELbase is available directly from Eastbay Softworks. For more info call 616-938-4445; to order call 1-800-968-3292.

Tim Winker

WHEELbase		1985 Saab 900 Turbo		120,155 Miles		JUNE 11, 1992	
Service Item List							
SERVICE ITEM	LAST		INTERVAL		NEXT		
	Date	Miles	Months	Miles	Date	Miles	
Log: Oil/Oil Filter							
DATE	MILES	BRAND	SERVICED BY	COST	NOTE		
11/01/85	1,078	Mobil 1	Tric Motors	8.00	warranty		
02/21/86	6,368	Mobil 1	Owner	20.75			
EDIT Record: Oil/Oil Filter							
DATE	MILES	BRAND	SERVICED BY	COST	NOTE		
08/30/87	33,245	Mobil 1 5W30	Owner	20.25			
(ESC) cancel—(F10) save							
03/06/87	25,227	Mobil 1	Owner	18.75			
06/10/87	29,270	Mobil 1	Owner	19.75	new drain plug		
07/31/87	31,302	Mobil 1	Owner	19.35			
08/30/87	33,245	Mobil 1	Owner	20.25			
11/13/87	36,182	Mobil 1	Owner	19.35			
Transmission Fluid	12/27/90	102,418	36	50,000	12/27/93	152,418	

(C)Copyright 1992 Eastbay Softworks

Record are saved in the Log for each Service Item, and may be easily edited.

Automap helps plan trips

Another interesting piece of computer software that gets much use here at Saab Club HQ is Automap. Automap is a computerized road atlas that also works like a "TripTick" from your favorite auto club in that it can assist you in planning a journey.

Like most popular programs it makes use of pull-down menus for ease of use. You begin by going to the SCREEN menu, then click on JOURNEY. You are presented with FROM and TO with the options of stopping at places not on the regular route, or VIAs. Once you have given the options, Automap calculates several different routes, marking those that are Quickest, Shortest and Preferred.

Automap presents the result in a TABLE, giving the Quickest route in steps from a few miles to a few hundred. Alternate routes can be chosen by entering SHIFT+F4. By keying ALT+M, routes are displayed on a map with the chosen route blinking, making it easier to visualize the journey.

If you wish to zoom in on a particular area, or zoom out for a wider view, Automap gives you the option. You can pan left or right, up or down, and add or remove details such as lakes, rivers, or state and national forests.

A mouse or trackball is helpful, but not necessary, in picking out details. Clicking the left mouse button on a square within a state displays details on that state, including, capitol, population, largest city, and phone numbers for tourist and road information. By clicking the right mouse button when the pointer is on an unnamed road, the route number or name is displayed, on the road and in a window in the upper right corner.

Major Canadian roads are also included in the Automap database, which helps calculate alternative routes for those who live in the far northern U.S.

Automap is not without its problems. It isn't very good on short journeys, and there are quite a few gaps in its database. It does work well for planning long distance trips, particularly by Interstate highway, or for learning the layout of the United States. It also takes up 4mb on the hard disk, probably not bad considering the vast amount of information available.

Another problem is that it can't show current road repairs, but then neither can a road atlas. An Automap BBS would be great for planning trips with up-to-the-minute road conditions. It would also alleviate the problems of missing data in the

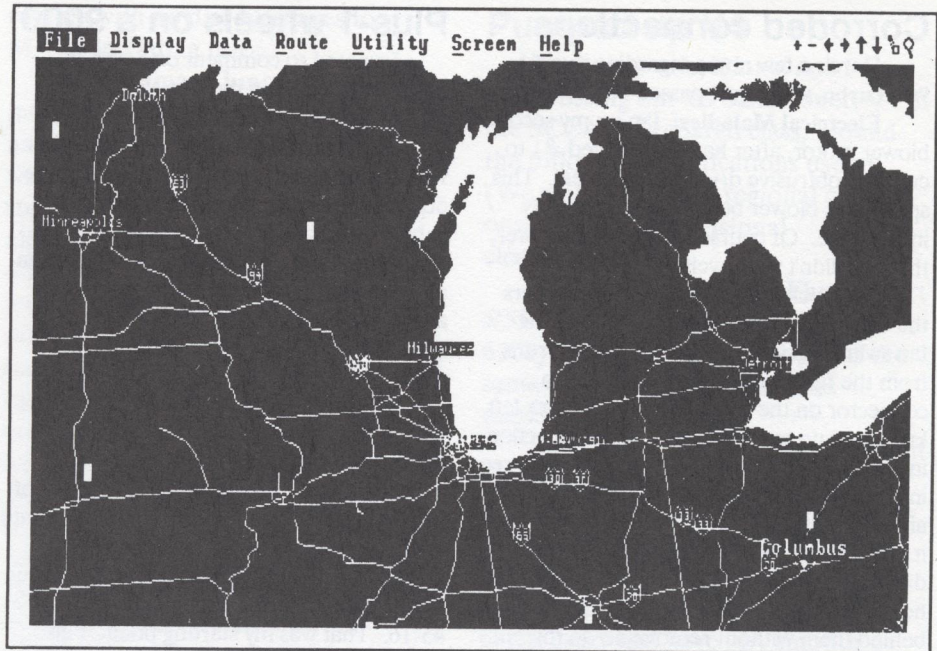

AUTOMAP displays several potential routes to aid in trip planning, flashing the preferred route on screen, in this case Duluth, Minnesota, to Columbus, Ohio.

current program and re-naming of roads by highway departments.

Suggested price for Automap, (current version: 2.04) is \$99.00, but it can be

purchased from most software retailers for under \$50.

Tim Winker

DATE	MILES	BRAND	SERVICED BY	COST	NOTE		
11/01/85	4,478	Mobil 1	Trio Motors	8.88	new warranty		
02/21/86	6,368	Mobil 1	Owner	21.75			
08/30/87	33,245	Mobil 1 SW38	Owner	28.25			
08/30/87	33,245	Mobil 1	Owner	19.75			
07/31/87	31,382	Mobil 1	Owner	19.35	new drain plug		
08/30/87	33,245	Mobil 1	Owner	28.25			
11/13/87	36,182	Mobil 1	Owner	19.35			
Transmission Fluid		12/27/90	182,416	36	58.888	12/27/90	182,416

Copyright 1992 Eastbay Software

Software for the IBM PC

- Extremely easy-to-use!
- Automatic service reminders--based upon time, mileage or both!
- Never again miss important scheduled service!
- Monitor all your vehicle operating costs!
- Track several vehicles!
- Fuel log calculates MPG!
- You can set service items for each vehicle!
- Vehicle related phone/address directory!
- Complete service records can increase resale!



1-800-968-3292



30-day
money-back
guarantee



eastbay software
P.O. Box 501 Acme, Michigan 49610-0501

WHEELbase™
VEHICLE MAINTENANCE MANAGER

Regular: \$49.95
Special Introductory Price
Only: \$39.95

Corroded connections

Here's a few notes regarding our '82 900 Turbo, which just passed 90,000 miles.

Electrical Maladies: I'm on my second blower motor, after having replaced #1 to cure the obtrusive dry-bearing squeal. This spring, the blower became intermittently inoperative. Of course, without the blower, the A/C didn't work well.

I had voltage at the fuse which covers the blower motor circuit, but none at the fan switch. The wiring between them runs from the fuse box, through a multi-pin connector on the sidewall by the driver's left knee, and up into the dash. The connection in the multi-pin plug (the upper one of three in that location) was corroded; unplugging and re-plugging with contact cleaner solved it. I removed the kneebar and heater distribution duct for better access; I think, however, it would be possible to reach up behind them without removal to do this.

The car didn't pass the state's smog inspection, as the oxygen sensor circuitry wasn't working. It turned out to be a bad connection in the wiring between the sensor and the computer.

This is the same sort of degraded connection which causes brake light problems when the tail light ground connection fails. It is an expected occurrence with older vehicles; I've had it in several places in our '82 VW. Just because the connection looks good doesn't mean it is. The seriously compulsive among us can open, clean and replug every connection in the car.

Air Conditioning Insulation: The A/C evaporator is located in the engine compartment, where it can absorb lots of heat. This isn't good for A/C efficiency. The factory installs gooey black rubber insulation over the copper coils. The insulation gets harder as the vehicle ages; in my car it eventually disappeared.

I got some suitable insulating tape and re-applied it. Because of the odd shape, the reapplication soon dropped off too - right into the belts. That was a mess I don't ever want to clean up ever again.

I provided insulation by taping a cardboard form in place over the coils, and filling the void with expandable foam from an aerosol can, such as is sold at hardware and home-improvement stores to fill hollow-core doors and walls. Some dribbled out as the foam expanded, but it was easily cut out with a knife and removed.

David Brick
Santa Cruz CA

Plus-1 wheels on a 9000

I wanted to comment on Stephen Hendrick's article in the March 92 issue regarding larger tires on the 9000s.

I have studied the handling problems with the 9000 for some time now and have done a fair amount of research on the subject with factory reps and specialists in the aftermarket wheel business. I wrote an article last year regarding the positive aspects of installing the Saab handling kit and mentioned my displeasure with the stock P600's, etc.

After 50K miles, I finally wore out the P600's and it was time to act on my research. MY goals were to improve the looks and handling without sacrificing all of the ride quality. To improve the turn-in rate and handling, I believed that going to a "Plus-1" setup was the right strategy. A true Plus-1 meant going from 205/55-15 to 205/45-16. That was my starting point. I also thought that ultimate handling might be accomplished with a 225/50-16. For looks (and ease of cleaning brake dust since no Metal master pads were available) I wanted to go with a 5-spoke Ronal type wheel.

I spoke with Pirelli factory reps and they referred me to several wheel manufacturers who might be interested in building an application for the 9000. Ultimately, reps from Hiyashi wheels (HRE) measured the clearances, wheel track, offsets, etc. They came to the conclusion that a 6½-inch rim was about as wide as practical and that 7-inches would be troublesome. The tire folks, as well as a few people that have tried 225/50-16s said that they rub under hard cornering without other modifications. So, I guess Saab engineers knew what they were doing when they gave us the 16-inch rims on the newer 9000s with 205/50 P700 Z's.

I also spoke with the Tire Rack folks. They are very nice and their prices are hard to beat, but they gave some outrageous recommendations for 7 to 8-inch rims, etc. that was contrary to most other qualified experts. They stand behind their applications, so risk of trying is minimal, but it was not worth trying for me. Saab wheel application for 9000s is not a big market, so their experience is extremely limited.

So what was my choice? Well, there was another factor that I had to consider and that was price. The ultimate setup with custom made wheels was more than it was worth. This is not a race car. For the price, I found that the Saab Aero/Talladega 6½ by

16-inch wheels fit my needs of size, good looks and easy to clean. For tires, I wanted the shorter side wall size to improve the turn-in and transition rates. This limited the manufacturers to a few. I went with the Pirelli P700Z in a 205/45-16. These tires are about ¼-inch wider than the 205/50's. The handling is great, the ride quality is very good and they are not as harsh as the P600's.

Since the stock 15-inch rims were only six inches wide (not 6½ as described by the Tech Talk article) going to a lower profile tire would only cause other problems. My setup clears everything and keeps the overall diameter close to even. I am sure there are other setups that would work out and even stickier tires but overall I am very pleased and get lots of compliments on the look. My car in an '88 9000 Turbo (last year's convention winner in the 9000 class) and is silver with an Eduradian Grey Aero Kit (air dam, side skirts, flares, etc.) so the grey colored Aero wheels really look good to me.

If anybody needs a set of 15-spoke 15-inch wheels, please check the want ads. But be careful of free advice of tire merchants that don't know the 9000 well. You often get what you pay for. As for other accessories, I have installed quite a few, from suspension and Aero Kit to CD players and lights. I would be happy to assist anyone trying to do the same.

One last unrelated item: I am sure that I am not alone in feeling left out by not having a local club chapter in the San Francisco Bay area. There was some talk at last year's convention about forming one, but nothing has come of it. Well, if you want something done, you have to do it yourself. Therefore, if you have some interest in forming and or joining a Bay Area chapter, please write to me or call 510-582-1858 and we will see what we can do to get one started.

Douglas Morse
25291 Morse Ct
Hayward CA 94542

KYB vs. Bilstein

KYB still means Keep Your Bilsteins even for a Plymouth Voyager. In my previous letter (June 91, #204) I stated, "Boy what an improvement! Better ride from the very beginning, and no change at all in 5,000 miles. All pitching so characteristic of Voyagers [with worn shocks was] gone. Reason: Less damping in jounce and much more in rebound with valving done to perfection."

By 8,000 miles the KYBs were riding hard; pitching was not the problem. The difficulty was that the KYB GR-2 shocks were sticking at the normal ride height position. I installed Bilstein gas shocks, which changed the ride and handling drastically. All kicking stopped, the handling improved, and the only objectionable feature is sudden stopping movement at the rear due to too much damping in the rebound. There has been no change in 3,000 miles.

The original front struts of the Voyager were made by KYB. By 25,000 miles they failed by sticking at normal ride height and losing all damping in rebound. The ride involved quite a pounding in front with the struts not "giving" much. With Koni not available, I bought Bilstein struts, which have a unique construction. To my consternation, they did not fit! There was a change from the 1989 to the 1990 model voyager not communicated to Bilstein. At last, I bought Monroe struts dirt cheap from PEP Boys and had them installed. Hmm! Perfect to start! Stay tuned.

Bridgestone Turanzas, recommended by Rick Parr of Parrformance, have been a great improvement on Goodyear Invicta GL tires on the Voyager, with all desirable attributes seemingly present in one tire. To Jim Oliver (June 92, #214) who bought Michelin MXLs for his 900S: These are the original equipment on my 1990 Saab 9000S, and are excellent except for transmission of rumble from coarse pavement. Rick Parr says that Bridgestone Turanzas will stop this

rumble with no disadvantages to MXLs, including price.

Bill Bartman (June 92, #214) is judging the handling of the 9000 too harshly and ignorantly. Compared with a 900, the 9000 has a numb steering feel on center, but exceptionally good feel under stress. In handling, the 900 understeered and really let you know about it with positive-offset steering geometry. The 9000 seems to have zero-offset steering, and lets you know from rear axle movement when the limit of adhesion looms. The 9000 is designed to be driven steadily through a bend with no setup needed. I have demonstrated to passengers that there is no change in direction (no yaw) by driving in circles going from full throttle short of wheelspin to no throttle to brakes on hard. Another variable is that the 9000 has far less sensation of speed than the 900, and will do more with no distress. It took me several thousand miles to overcome the "numb" feel of the 9000 and realize how fast it can be driven. (For the worst in FWD steering and handling, try a Hyundai Excel, preferably one with a few miles on it so that the kicky shocks add their effect.)

The size of the 9000 is very much to my liking. Our 900s had such narrow cabins that elbows collided in front. Besides, the 9000 is 150mm shorter than the 900. Since I have had the 9000, the cabin sizes of everything from Honda Accords to Infiniti Q45s seem pitiful by comparison.

Bartman's terror of a GM steering system is particularly out of place, since a Saginaw (GM) power steering pump had been used from the first on his pet 900s!

Except for BMW and Mercedes models with 4WD, Saab 9000s are generally superior, in my opinion. Also, FWD with traction control seems to be in the same league as 4WD without it. The former is cheaper, gives more room, and uses less fuel.

Dr. Joel M. Kauffman
Philadelphia PA

Pumped up V4

While my wife, Diane, and I were autocrossing our '69 Saab Sonett V4 in the SCCA E-Prepared class, I found the following modifications useful. (We won five SCCA regional championships and one divisional championship.)

Rear Sway Bar - J.C. Whitney part #55-4508B, \$75.00 (phone 312-431-6102). Made by Addco, who sells the same bar for \$150.00. Reduces understeer.

Springs - Cut one coil off the front and rear stock springs if you are serious and local roads are good. This increases the spring rate and lowers the car's center of gravity and roll center. If you are *really* serious and partly crazy and have *very* smooth roads (or don't intend to drive on the road), replace the stock springs with 350 lb. fronts and 150 lb. rears. Ford Ranger springs will work for the front, rear can be the front springs from a two-stroke Saab.

Oil Pump - Ford 2800cc V6 oil pump gives higher volume for the V4 engine. Check a local parts house.

Camshaft - Isky Rally 1-3/4 cam works great for street and autocross. Isky advertises in hot rod magazines.

Many other V4 (and 99) performance parts are available from Motor Sports Service (MSS), 1400 East 2nd Street, Jamestown, New York 14701; phone 716-665-4200.

Mike Tucker
Hartsville SC

Early Saab exhaust parts

Don't overlook J.C. Whitney (312-431-6102) for exhaust systems for two-stroke and V4 Saabs. They have sold Starla, made in Sweden, original equipment Saab exhaust parts for years, and cheap. Front mufflers for two-stroke and V4 are priced in the \$30-\$40 range. I can't believe anybody's friendly muffler shop could make a "critical tuned resonator" duplicate for that price.

Rob Allen
Hamden CT

CAMPBELL/NELSON
Auto Wrecking

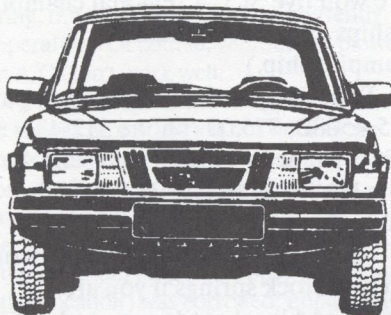

SAAB

USED PARTS CENTER
205th & Aurora, P.O. Box 220
Edmonds, WA 98020
1-206-771-4931
1-800-552-2999
(Out of State)

Mixed metals

At 245K miles, my '74 99 was in need of a ring job. After dismantling the engine, I was pleasantly surprised to find very little ring wear in the cylinder walls. A standard refitting was in order and I opted to use the less expensive Japanese replacement parts.

Now, after only 50,000 miles, the engine is basically blown and shows signs of severe ring wear. The only explanation I can offer suggests an incompatibility of metals.

I saved a couple of hundred dollars, but severely cut short the life of my engine as a result, and I wanted to pass the horror story on. Not to in any way suggest that my experiment provides evidence of the deficiency of Japanese product, but rather to say, "Don't mess with the best!"

Valhalla, I am coming.

Sam Sparks
Tacoma WA

Swede Swipes Saab Series

Swedish driver Robert Amren wrapped up this year's Zerex Saab Pro Series at Road America in August. Amren's win at the Wisconsin track, his fifth victory for the year, gave him the championship with several races still to be run.

Amren's win at Road America wasn't easy, however. The pole was held by 18-year-old American Elton Julian (in just his second-ever Zerex Saab race), followed by Ashton Lewis and Alex Padilla. Lewis and Padilla both had a shot at winning the title, but they had to beat Amren to the checkered flag to do so.

Amren was not about to be beat as he took an early lead and held it throughout the race, though challenged by Padilla and Lewis. Padilla spun out in the effort, Lewis finished second only 1.8 seconds back, with Julian right behind.

Along with the title of 1992 Zerex Saab Pro Series Champion goes the \$100,000 General Rent-A-Car Pacesetter Career Enhancement award. Amren is the second foreign born champion of the series.

Cars for the Zerex Saab series are identical formula cars powered by turbo-charged Saab 2.0-liter engines.

ESPECIALLY FOR THE 16 VALVE 900 TURBO!

For the discerning individual who wants to get the most performance from their SAAB Turbo, we have a collection of our very best performance upgrades. These items have been carefully matched to give the ultimate performance boost, while still maintaining all the reliability that is built into your SAAB. Now you can run with the big boys without any of the inconveniences normally associated with super high output engines.

All of the parts in this kit are **easy to install**, whether you ask your mechanic to do it or choose to bolt them on yourself. All have been proven over several years of testing and actual use. The only surprises with this kit are the unbelievable performance gains. How unbelievable, you ask? Well, each car will vary slightly, and there are some year to year differences between engines, but our testing on a 1987 turbo showed an increase from **160 to 224 horsepower!** How did we do it? Just look at everything you get. First, our famous **Modified APC box**, only the one included in this kit has a special "Stage II" calibration. Matched to this is our "Stage II" **Fuel Pressure Regulator** which increases fuel flow at full boost by nearly 12%. To light the fires, our **Stage II ignition package** adds high energy and computerized timing control for each individual cylinder. You also get our complete **Sport Exhaust package** and our new **Air Inlet modification**, which replaces your clunky old air filter housing with a fully exposed K&N permanent filter. To round the package off, we have included a special **Ignition Coil**, a set of our custom lifetime guaranteed **8mm Silicon Spark Plug Wires**, and a complete set of **Spitfire Spark Plugs**.

All of this equipment is hand-matched by our special calibration procedures before it is shipped to you to insure that you get the best possible performance increase. The plugs are re-gapped, the ignition system coil driver output is increased and matched to the coil, fuel pressure increase rates are specially selected and the APC box is calibrated to take full advantage of the new timing control and higher fuel flow. This package produces the ultimate in useable street power. The result is an engine that starts at the first turn of the key, idles smoothly, gets good fuel economy and in many cases turns the tires in third gear!

Picture it. You pull up next to a BMW 750 in all its 12 cylinder magnificence. The BMW's hood rises as the driver buries his foot in it to put you back in your place. Because you have always been a decent person, you at least do him the courtesy of dropping down to third gear before giving him the opportunity to examine your taillights, and you motor off with the glowing satisfaction of knowing that one more person believes in the automotive magic worked by Trolls (even if the Group 6 Wizards had to help).

Now all this can be yours now for **JUST \$1495!**

Order Your Performance Package Now!

Group 6 Performance

Call Toll Free: 1-800-722-1809

The Government May Be The Next Owner Of YOUR Car!

Our government wants to crush all cars & trucks made before 1980. Elected federal and state officials have introduced and continue to introduce legislation that would rid our highways of all pre-1980 vehicles or tax the owners and operators of these automobiles. Listed below are a few examples. Please make a copy of this form letter and mail both copies to your respective state senators using the address on the letter! It's up to you, the voting American, to get involved!

Subsection (A) : "The Secretary of Energy shall provide *financial assistance to State programs* encouraging the voluntary removal from use and the marketplace (of) pre-1980 model year automobiles..."

Subsection (B)-(2): Any rules adopted by the Secretary of Energy...shall require that *to qualify for Federal assistance* under subsection (A), *at least 50 percent of the cost of the program be paid for from State or private funds.*"

National Energy Security
Act of 1991
To Accompany - S.1220
June 5th, 1991

"An accelerated retirement program, simply stated, buys old cars and retires them faster than they would have been retired in the absence of the program...*Controlling previously uncontrolled or minimally controlled sources might be cheaper than tightening controls on already highly regulated emitters, whether stationary sources or new cars.* In many areas, old cars are one of the few remaining significant sources of criteria emissions that have not yet been controlled."

Accelerated Retirement of Vehicles
Prepared under Section 108(f) of the
1990 Clean Air Act
March 1992

"President Bush again has environmentalists crying foul over a ruling they say weakens the Clean Air Act of 1990. The self-declared environmental president overruled his EPA chief last week in quietly granting industry a concession on emissions...Bush's ruling eases the approval process for plants when operational changes increase emissions of pollutants beyond what their permit allows. The ruling was opposed by Environmental Protection Agency chief William Reilly who had argued that the law required public notice and review when emissions would exceed permit levels."

USA Today
May 18th, 1992

"President Bush acted yesterday to let oil refineries and other industrial polluters meet federal clean-air standards by taking up to 40 million old cars off the road instead of curbing their own smoke-stack pollutants."

The Washington Times
March 20th, 1992

"A legislative struggle in California to salvage a troubled budget has resulted in important changes in registration fees...the Department of Motor Vehicles has the power, (AB758-passed June 28th, 1991), to charge a registration fee based upon the *current* (possibly collectable) *market value* of that vehicle."

Classic Auto Restorer
February 1992

Clip & Mail

Honorable _____
United States Senate
Washington, DC 20510

Dear Sir,

This letter is to voice my strong opposition to any and all legislation which would encourage the scrapping of pre-1980 motor vehicles for environmental or economic reasons.

I urge you to vote NO to any legislation that is not in the best interest of the millions of old car enthusiasts and would destroy a multi-billion dollar industry made up of thousands of small businesses supplying these enthusiasts.

I urge you to vote NO to any proposal that would penalize or unjustly tax owners of older vehicles or in any way, shape or form, restrict operation, ownership and the right to drive and enjoy these automobiles.

Stop bowing to the demands of big business and fanatical doomsayers and stand up for your constituents. As an active collector car hobbyist/concerned citizen, I, and millions of others, are prepared to fight for the right to keep and enjoy our old automobiles.

Sincerely,

(Signature)

Name _____

Address _____

City _____ State _____

Zip _____ # of Licensed Voters (Over 18) _____

Clip & Mail

**Look for a complete list of U.S. Senators
on the reverse side of this flyer.**

For more information send a S.A.S.E. to:
Clunker News; P.O. Box 13372; Ft. Wayne, IN 46868-3372

UNITED STATES SENATORS

Alabama

Howell Heflin
Richard C. Shelby

Alaska

Ted Stevens
Frank H. Murkowski

Arizona

Dennis DeConcini
John McCain

Arkansas

Dale Bumpers
David Pryor

California

Alan Cranston
John Seymour

Colorado

Timothy Wirth
Hank Brown

Connecticut

Christopher J. Dodd
Joseph I. Lieberman

Delaware

William V. Roth, Jr.
Joseph R. Biden, Jr.

Florida

Bob Graham
Connie Mack

Georgia

Sam Nunn
Wyche Fowler, Jr.

Hawaii

Daniel K. Inouye
Daniel K. Akaka

Idaho

Steve Symms
Larry E. Craig

Illinois

Alan J. Dixon
Paul Simon

Indiana

Richard G. Lugar
Dan Coats

Iowa

Charles E. Grassley
Tom Harkin

Kansas

Robert Dole
Nancy Landon Kassebaum

Kentucky

Wendell H. Ford
Mitch McConnell

Louisiana

J. Bennett Johnston
John B. Breaux

Maine

William S. Cohen
George J. Mitchell

Maryland

Paul S. Sarbanes
Barbara A. Mikulski

Massachusetts

Edward M. Kennedy
John F. Kerry

Michigan

Donald W. Riegle, Jr.
Carl Levin

Minnesota

Dave Durenberger
Paul David Wellstone

Mississippi

Thad Cochran
Trent Lott

Missouri

John C. Danforth
Christopher S. Bond

Montana

Max Baucus
Conrad Burns

Nebraska

J. James Exon
Robert J. Kerrey

Nevada

Harry Reid
Richard H. Bryan

New Hampshire

Warren Rudman
Robert C. Smith

New Jersey

Bill Bradley
Frank R. Lautenberg

New Mexico

Pete V. Domenici
Jeff Bingaman

New York

Daniel Moynihan
Alfonse M. D'Amato

North Carolina

Jesse Helms

North Dakota

Quentin N. Burdick
Kent Conrad

Ohio

John Glenn
Howard M. Metzenbaum

Oklahoma

David L. Boren
Don Nickles

Oregon

Mark O. Hatfield
Bob Packwood

Pennsylvania

Harris Wofford
Arlen Specter

Rhode Island

Claiborne Pell
John H. Chafee

South Carolina

Strom Thurmond
Ernest F. Hollings

South Dakota

Larry Pressler
Thomas A. Daschle

Tennessee

Jim Sasser
Albert Gore, Jr.

Texas

Lloyd Bentsen
Phil Gramm

Utah

Jake Garn
Orrin G. Hatch

Vermont

Patrick J. Leahy
James M. Jeffords

Virginia

John William Warner
Charles S. Robb

Washington

Brock Adams
Slade Gorton

West Virginia

Robert C. Byrd
Jay D. Rockefeller IV

Wisconsin

Robert W. Kasten, Jr.
Herbert H. Kohl

Wyoming

Malcolm Wallop
Alan K. Simpson

GET INVOLVED!

If you are a car enthusiast, be it someone who enjoys looking at vintage American iron, or a person who owns a fleet of Cadillacs, you need to get involved. If you are a member of a car club, let the rest of your members know. If your club is a member of a national organization, let your national officers know. It's up to the car enthusiast to stop this movement before the cars that we love are either crushed, taxed (because of ownership), or restricted from travel on our public highways. If you don't react now, memories and pictures will be all that you have left. Government and "big business" will make sure of that!

SAAB Club Gifts

**New
SAAB CLUB
Golf shirts**

100% cotton, white, new logo on left breast, specify size, M, L, XL, #261 **\$19.00**
 XXL, #262 **\$24.00**



SAAB Club License Plate Frames

Black plastic frames fit all Saabs.
 #301 **\$3.00 ea**
 #302 **\$5.00/pr**

SAAB Club decals - Blue & yellow on adhesive backed vinyl for window, bumper or trunk. Mailing included.
 #901 **\$1.50 ea**
 #902 **4 for \$5.00**



40th Anniversary T-Shirt (1950-90)
 Jack Ashcraft design features SAAB 92, 9000 Turbo and J-37 Viggen jet. 100% cotton. Small or Medium only, (L & XL Sold out) was \$12.50,
#251 - CLOSE OUT \$9.00

92-09 rev.

SAAB Repair Manuals & Books

HAYNES WORKSHOP MANUALS - Great for Do-It-Yourself repairs. Recognized by enthusiasts and professionals for their thorough instructions, clear photos and accuracy. Each manual is based on a complete teardown and rebuild of the model.

- #101 - 95/96 V4, 1966 - 1975 **\$15.00**
- #102 - 99, 1969 - 1980 **\$15.00**
- #103 - 900, 1979 - 1988 (Incl. Turbo & 16-valve) **\$15.00**

#131 - 95, 96, Monte Carlo 850, 1961-64 -This 250-page reprint of the Saab factory manual covers the early 850 engines as well as the 750-GTs and the Monte Carlo 850s. Size 5½ by 8½, and bound just like the original. **\$25.00**

FUEL INJECTION MANUALS -

#104 - **Bosch Fuel Injection & Engine Management** by Charles Probst, SAE. Explains the theory, troubleshooting and service of all Bosch fuel injection systems including K-Jetronic (CIS, 99s and 8-valve 900s), and the more recent LH-Jetronic (16-valve 900s and all 9000s). **\$30.00**

#105 - **Bosch Electronic Fuel Injection Systems: Shop Manual** (1986) 96 pgs. 207 ill. Covers 1970-1979 models only. This manual has photos and diagrams of Bosch F.I. systems, but lacks good technical descriptions. A good companion to the above manual. **\$15.00**

#106 - **How To Tune and Modify Bosch Fuel Injection** by Ben Watson (1992) 160 pgs., 250 ill. This handy guide will help you coax better mileage and top performance from your Bosch fuel injection system.

NEW! **\$20.00**

(More books on next page)

Add \$3.00 per order for shipping, plus \$1.00 for each additional item. (Shipping included on decals and back issues.) Shipping to U.S. and APO Addresses only. Allow 4 to 6 weeks for delivery. Sorry no phone orders or C.O.D.s.

Send check or Money Order to:
SAAB CLUB GIFTS
2416 London Rd, #900
Duluth, MN 55812-2221

Name _____

Address _____

City _____ State _____ Zip _____

Daytime Phone (in case we have questions): _____

Quan.	Item#	Description	Size	Price ea.	Total
				Shipping	
				TOTAL \$	

CUSTOM-MADE SEAT COVERS



Front and rear seat covers are available for all SAAB 900 and 9000 series. Heavy duty polyester/cotton material is easy to install, machine washable. Prices start at \$79.95 plus \$6.00 freight. Guaranteed fit. Available colors: Black, Burgandy, Brown, Silver Grey, Red, Navy Blue, Tan, White and Charcoal. With or without SAAB logo. VISA, Master Card, and A. E. cards accepted. All orders shipped in 48 hours.

Free brochure, write:
JEAN SEAT INTERNATIONAL
 PO Box 7798; Hollywood, FL 33021
TO PLACE AN ORDER, CALL:

1-800-881-0509
 Outside USA (305) 963-4989

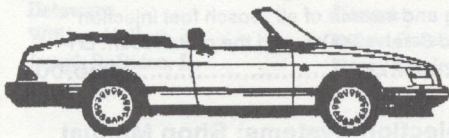

Back Issues of NINES

The following back issues are still available. The supply of those marked with an asterisk (*) is very limited. Prices include mailing to U.S. addresses.

Cover date	Price
November 1987	\$2.50
October 1988	\$2.50
January 1989	\$2.50
March 1989	\$2.50
May 1989	\$2.50
July/August 1989	\$2.50
September 1989	\$2.50
October 1989	\$2.50
November 1989	\$2.50
December 1989	\$2.50
February 1990	\$2.50
March 1990	\$2.50
May 1990*	\$2.50
June 1990	\$2.50
September 1990	\$2.50
October 1990	\$2.50
November 1990	\$2.50
December 1990	\$2.50
Feb/Mar 1991 (Issue #200)	\$5.00
Any other 1991 issues,	\$3.00 ea
January 1992, #210	\$3.00
Feb/Mar 1992, #211/212	\$5.00
April 1992, #213	\$3.00
June 1992, #214	\$5.00

Collection of all 10 '91 issues, \$30.00

Collection of all remaining issues (over 25), total value over \$80.00.

\$50.00

Includes U.S. postage.
 Postage to Canada: add \$3.00 US
 Postage to overseas (Surface mail): add \$8.00 US

NEW! Official Saab 900 16 valve Service Manual 1985-1992

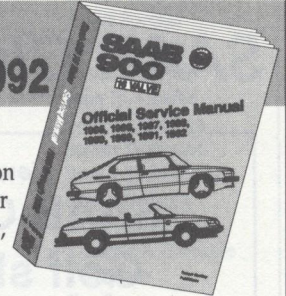

This new Official Saab Service Manual is the only factory-authorized, comprehensive, single source of service information and specifications available for Saab 900 16 valve cars. Whether you're a professional technician or a do-it-yourself Saab owner, this manual will help you understand, care for, and repair your Saab.

Everything from fundamental automotive concepts and maintenance procedures to complex electrical system troubleshooting and complete engine overhaul is clearly explained. Critical updates and information from the Saab Service Information Manual, the Parts & Service Information System, and Saab Service Training have been included, as well as fast, proven repair procedures and tips used by Saab technicians. Even if you never intend to work on your Saab yourself, you'll find that owning the Bentley Manual will help you discuss service work more knowledgeably with your Saab service professional.



#107 - Official 900 16-valve Service Manual
 Coming Soon! Suggested retail, \$49.95

Saab Club introductory offer \$45.00
 (price good through 12/31/92)

More Books about Saab

BROOKLANDS BOOKS - Collections of articles, road tests, new model reports, specs and comparison tests from the world's top automotive magazines.

- #111 - Saab Sonett, 1966 - 1974 \$10.00**
- #112 - Saab Turbo, 1976 - 1983 \$15.00**
- #113 - CAR and DRIVER on Saab, 1956 - 1985 \$15.00**
- #114 - ROAD & TRACK on Saab, 1955 - 1984 \$15.00**

#122 - From Two-Stroke to Turbo: SAAB in Motorsports, by Anders Tunberg. (1980) 132 pgs. Thirty years of Saab's rally and racing achievements. Recalls the exploits of famous Saab rally drivers such as Erik Carlsson, Stig Blomquist and Per Eklund **\$10.00**

#123 - The Sonett and All Other SAAB Sports Cars, by Bjorn Svalner. (1983) 144 pgs. 150 ill. Well illustrated history of Saab's fiberglass-bodied sports cars, including the Super Sports (Sonett I) of the mid-1950s. Printed in Swedish with English translation. **\$25.00**

#125 - The First 40 Years of Saab Cars - by Bjorn-Eric Lindh. (1987) 200 pgs, 500 illus. The most complete history of Saab available. Covers the development of all models from the two-cylinder two-strokes of the early '50s through today's turbocharged, luxury models. **\$29.50**

Order form on previous page

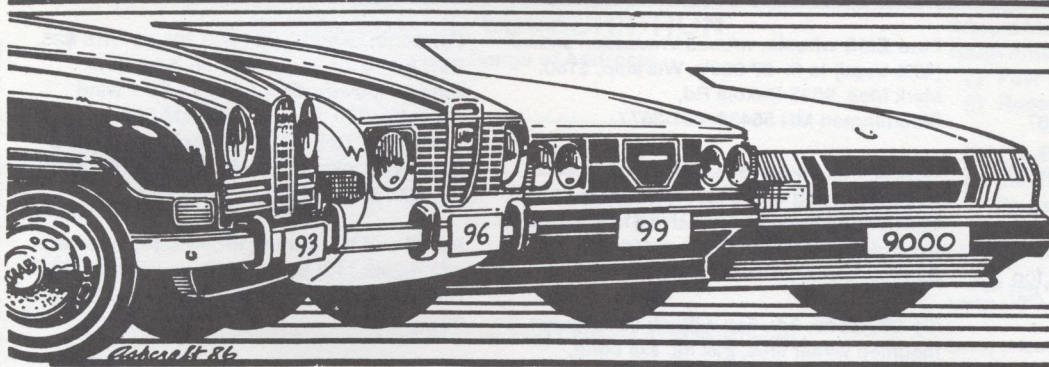

SAAB SWAP

CLASSIFIED ADS

CLASSIFIED AD RATES

Ads offering parts or SAABs for sale or wanted are available to members and non-members. Ads are limited to 25 words, plus name address and phone number. Ad copy will be abbreviated and excess words deleted where possible. Enclose sufficient funds with your ad, we **do not** bill. No ads will be taken by phone or fax. The Classified Ad rate is as follows:

	Members	Non-members
CARS FOR SALE	\$10.00	\$15.00
PARTS FOR SALE	\$5.00	\$7.50
WANTED ADS.	\$2.00	\$3.00
COMMERCIAL ADS (Parts & Services)	\$10.00	\$15.00
EVERY 5 EXTRA WORDS	\$1.00	\$1.50

DEADLINE: The 15th of each month for the following month's issue, e.g. January 15th for the February issue. Newsletters are mailed the first week of the cover month.

COMMERCIAL DISPLAY ADS: Contact the editor for rates and info. Deadline, the 10th of each month for the following month's issue.

6 new '70 Sonett alloys, \$125 ea. Used Sport & Rally V4 2 bbl carb/manifold/air cleanr \$600. New 9615 front spoiler, \$200. 95 Euro rubber side mouldings for rear bumper, \$150. Euro hdltts/grille, aluminum, \$350. '69 Sonett V4 for restoration \$1500. Rob Allen. 203/248-8798.

A ton of new & used stroker & V4 parts: drivetrain, electrical, interiors, body, etc. Call or write with your needs. Inventory in process. Rob Williams, P.O. Box 25692, Salt Lake City UT 84125. 801/250-1877.

99s, 900s, 9000s For Sale

'89 900T Convertible, 5-spd white/tan leather, immaculate 34K mi. \$18,900. Dan Paradis, 114 Apollo Rd, Montrose CO 81401. 303/249-6920.

'88 900 SPG, triple gray, 44K mi, stereo upgrade, remote alarm, phone, many Saab acces. \$12,000. Steve Robbins, 48 Hilton St, Darien CT 06820. 203/655-3618.

'84 900 T, 4 dr, blue, 109k mi, loaded, rebuilt trans, runs like new, exc cond, \$4,000. Ton Dinh, Rt 1 Box 726A, Barboursville VA 22923. 804/973-3528.

'83 900S, 3dr, 120k mi, blue. Good cond, new Clarion stereo, dashboard, CV joints, exhaust, etc. Needs trans work. Best offer takes it. Asking \$1200. Greg Gulik, 4633 N Lawler, Chicago IL 60630. 312/725-8721.

'78 99 Turbo, Concours 1st place at Columbus, maroon, spotless inside/outside. Sway bars, many extras, too much to list, \$8k spent. 95k mi. See photo in this issue. Call for photos/info. \$3795. Gary Stottler, 1070 West Dawson Rd, Milford MI 48381. 313/684-2381, or 313/685-5730 days.

'77 99 EMS, San Francisco Auto Expo factory demo. Factory A/C, good tires (2 P6's), slight surface rust, so-so interior, needs eng & trans work. \$400/obo. David Neiman, 1360 Burrows Rd, Campbell CA 95008. 408/379-3773.

'74 99 EMS, silver, some rust, runs, current inspection, many spare parts, \$500. obo. Brad Wertheimer, 2102 Brandywine St, Philadelphia PA 19130. 215/972-0687.

Sonetts For Sale

Two '74 Sonetts, both run, one has serious rust. Have good extra frame, engine, & parts for rebuilding. G.E. Newson, 1700 SW 27th St, Topeka KS 66611. 913/232-4805.

'73 Sonett, 50K mi, refurbished, many new parts, many spares, fair cond, needs paint. \$3000./obo. Dave Dahms, Box 336 RDZ, Barto PA 19504. 215/845-2726.

2 '68 Sonetts, one is running, both are complete & need repair. \$4000, or separate. Robert Garber, 41841 Lawrence Ct, Elyria OH 44035. 216/322-6226 lv msg.

93s, 95s & 96s For Sale

'69, '72 Runners, Solid frames. '69 needs body work & brake m/cyl. AZ fenders, door, new inner fender & Weber carb + other parts. \$975 obo. Mark Lazerson, 7 Dairy Farm Rd, Stony Brook NY 11790. 516/632-7749.

'69 95 Wagon, V4, 4 spd, exc mech cond, recent paint & chr bumpers, nice int. w/am-fm cass, books, tools, records, very clean, runs great. \$3000 obo. Gary/Carol Gouveia, 696 Vista Pacifica, Pismo Beach CA 93449. 805/544-8841 or 773-3976.

'67 96 Stroker, White, clean, fresh everything, very straight, must sell. \$2,900. '68 96-V4, Red, tight. \$2,000. Rob Williams, P.O. Box 25692, Salt Lake City UT 84125-0692. 801/250-1877.

'67 Monte Carlo, rare, 3 cyl, orig. unrestored, not running. \$3,500 obo. '67 GT96, race ready, 3 cyl, roll bar, fiberglass buckets, headers, triple carbs, stainless steel expansion chamber. \$5000 obo. Engine parts for Saab 3 cyl. Also 2 extra bodies, offers. Ugo Piccagli, 4511 Harry's Ln, Dallas TX 75229. 214/247-6767. Fax 214/484-5574.

'66 MC850, no engine, otherwise complete. Floorboard very rusty. \$800. Brian Hanson, 306 Franklin St, Quakertown PA 18951-1726. 215/538-7957.

'72 96, a real gem, forest green, very little body rust, runs great, only 79,000 mi, \$3000/ obo. Marian Cremin, 71 W 109th St #5B, New York NY 10025. 212/866-3448.

2 Stroke and V4 Parts

Used 96 parts, body & interior parts. '69 model. Alan Buck, 6666B Bell Bluff Ave, San Diego CA 92119-1117. 619/265-1617.

**99, 900, and 9000
Parts and Accessories**

Newsletters 10+ yrs-#60 (5/78) to #187 (12/89), missing #144, #176. \$100/obo. Steve Young, 37 Velie Rd, LaGrangeville NY 12540-5512. 914/223-5613 (7365 Fax).

9000 Wheels, 15 spoke 6"x15" p/n 89-65-212, exc cond. \$200. ea/obo, will ship. Stock fog lights \$50. pr. Douglas Morse, Hayward CA. 510/537-7070.

900 radiator, \$50., radiator support \$90. Five 24-spoke alloys \$75/\$300. dash \$50. A/C compressor \$100. 99 3 EMS alloys \$60./\$150. Four steel wheels \$10./\$30. Pedro Tai, 400 Wagner Creek Rd, Talent OR 97540. 503/535-9055.

4 Avon 205/60VR15 tires, (2700 mi) on flat-disk-style alloy wheels (no problem on earlier cars) \$520. Temp-use spare tire (unused) \$75. EMS steering wheel \$45. Instrument panel rheostat (new) \$15. Bra \$25. Car cover (with stuff-sack) \$20. Mark Possoff, PO Box 11, Haverford PA 19041. 215/896-8098 eves.

99, 900 Headliner kit, comes w/glue, 3 1/2 yds & complete instr \$87.50. Other parts available. **Trollhattan Motors Inc.** 1015A Old Eastern Av, Baltimore MD 21221. 410/682-4688 or (1-800 32 TROLL).

Four EMS wheels, w/used Vredestien snows (40% tread) to fit -87 900's. Will ship, \$180. Mark Moe, 9533 Dakota Rd, Bloomington MN 55438. 897-3577.

Soccer Ball alloys, \$45. Rblt 8V head \$365. Rebuilt steering rack \$197. Alternators \$65-95. 16V head \$375. New AIC valve \$118. New disc rotors \$38. **900 Club**, PO Box 410634, San Francisco CA 94141. 800/377-2582.

'91 900 base, 3dr, 5sp w/Saab security sys, 2 mounted winter tires, 23k mi, exc cond, \$13,900, expanding family - buying van. Paul Sutton, 60 Hillcrest Ave, Edison NJ 08817. 908/819-8874.

Four 15-spoke alloys, from '85 900T, shod w/ 12k mi Yokohama A-509s (205/60-HR15). Exc cond \$600. Mark Buchholz, St Louis MO. 314/645-2431.

Parting out: Thirty-four 99's and forty-one 900's, '73-'88. One '86 9000. One '88 SPG Anthracite. VISA/MC. Rod Beckner, 604 E 1st St, Albany OR 97321. Tele/Fax 503/928-6351.

Four '86 900T alloy wheels, (89 65212), 15 spoke 6"x15" w/new (7-8mm tread) Dunlop 205/55 ZR15 D40 M2 tires. All wheels exc, w/in 0.3 mm TIR. Wheels & tires \$750. 4 tires only \$400. Wheels \$400 for 4 or \$125 ea. David Tatem, Box 141, Thompson CT. 203/923-3221.

For 9000: used Pirelli P600 205/55VR15 \$25. F&R brake rotors, just turned, \$40. Rear window louvers, \$50. For 900: Roof wind deflector, \$20. For 99: OEM AM-FM stereo radio from '73 EMS \$10. Jack Vines, 3227 E 28th Av, Spokane WA 99223. 800/669-7882 (o), 509/535-8610 (h).

9000T red box tuning kit, APC replacement unit (02 43 113) 86-89 \$150. new in box. Paul Bottone, 7104 E Jarvis Pl, Denyer CO 80237. 303/741-2717.

99, 900 parts, all kinds. Low prices to keep your older Saab running. We ship UPS-COD. **High Peaks**, 351 Lindley Ave, Asheboro NC 27203. 919/626-7117.

900 Bumpers, \$35. 99 hoods \$50. Rotors, \$25. Calipers, \$30. 99 heads, \$50. Idler shafts, \$75. CV joints, \$60. 4 Gislaved snows, used one season, \$200/obo. Super Inca's 3 mo.s old, \$500. Complete Turbo front pipes \$35. 8V starters \$40. Mike Connelly, 50 Bates Av, Coventry RI 02816. 401/822-2143.

900 sway bar set, \$150. New APC red box, \$175. 900 radiator, \$100. '87 S eng non-turbo 16v, low mi, \$1000. 87S cat converter, \$150. '86 factory manuals, \$150. 4 Inca alloys, \$500. '85 Turbo EQ, \$50. '87S ECU computer, \$200. Black eggcrate mats, \$45. 9000 km/hr speedo, \$50. Rob Allen. 203/248-8798.

Former Saab Dealer from '65-'74, all Saab tools, manuals & many Saab parts, plus Halda Spd Pilot, Eng/Trans stand, etc. Robert Fyvie, 201 1st St, Newberry MI. 906/293-3105.

Saab Clarion AM/FM cass unit, w/factory spectrum analyzer, part #02 73 045, w/code. From '86 9000T. \$250. David Tatem, Box 141, Thompson CT. 203/923-3221.

Alpine #7380 Digital FM/AM cass head unit. DIN mount w/quick release bracket. Dolby B noise reduction, radio monitor, music sensor, dual pre-amp outputs, 24-sta presets, more! \$125 ppd. Pat Bolmeyer, 1407 Oak Hill Rd, Wilmington DE 19805. 302/994-6357 6-9pm ET

Wanted, All Models

Red box or Group 6 FI Computer for 85 16V T, 16" wheels/tires for '87 9000, shop manuals for 9000. Jack Vines, 3227 E 28th Ave, Spokane WA 99223. 800/669-7882 w, 509/535-8610 h.

Saab factory manuals, parts books, sales literature, posters, calendars, dealer signs, pedal cars, toy cars, especially old and odd, also contact for trading same and 93 parts. Rob Allen. 203/248-8798.

Owners manual for '67 Sonett II (3-cyl). Original preferred, copy OK. Rob Williams, P.O. box 25692, Salt Lake City UT 84125-0692. 801-250-1877.

Low Cost
TURBO REPAIR PARTS

TURBO SAABS!
Beat the high cost of service and repair . . .
For all imports: including the Saab 900 and 9000

WE OFFER:

- Replacement Turbos & Cartridges
- Repair Kits
- In-House Rebuilding Services
- Performance Turbos

SEND YOUR TURBO REPAIR PROBLEMS TO US!

- HIGH QUALITY
- FAST TURNAROUND
- FULL WARRANTY

TURBO CITY
PERFORMANCE HEADQUARTERS

1137 W. Katella Ave.
Dept. SAAB • Orange, CA • 92667

We Accept:  

(714) 639-4933

MEMBERSHIP/SUBSCRIPTION

(Use also for Change of Address)

NAME _____

ADDRESS _____

CITY/STATE/ZIP _____

HOME PHONE _____ WORK PHONE _____

SAABS CURRENTLY OWNED _____

(i.e. '84 900 S 4dr. automatic / '78 99 GLE 5dr. 4-spd / '72 Sonett III / '68 96-V4 Deluxe)

Address change only - old Zip Code _____

Annual Membership fees for the SAAB Club of North America/NINES are as follows:

- First Year \$29.00
 Renewal \$25.00

- Canadian add \$4.00US
 International add \$8.00US

Please check appropriate box(es)
 (Canadian and International -- Money order or check payable on a U.S. bank only. Cash OK.)

First year members receive the most recent back issue of NINES and two SAAB Club stickers.

MAKE CHECKS PAYABLE TO "THE SAAB CLUB"

Mail to: The Saab Club of North America
 2416 London Road, Unit 900
 Duluth, Minnesota 55812

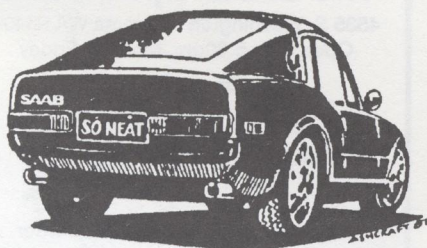

Rear View

Every now and then I wade through the database to get an idea of the distribution of Saab models among the membership. The last time I printed this info was in January, 1988. Of the over 5,000 names on the mailing list, 4,183 have reported which Saabs they own on their renewal cards. If totals don't seem to add up, particularly under Sonett, it's because not everyone specifies which variant they own. Some members own more than one model, so the total percentage is more than 100.

Model	Num.	Percent
Two-stroke (93/95/96-'68)	215	5.14%
V4 (95/96 1967-'73)	419	10.02%
Sonett (all 1967-'74)	312	7.46%
Sonett II	21	
Sonett V4	58	
Sonett III	203	
99 (all 1969-'80)	706	16.88%
Turbo only	90	
900 (all 1979-)	2666	63.73%
Turbo only	1191	
SPG only	70	
9000 (all 1986-)	740	17.69%
Turbo only	470	

Percentages for the first three model groups have not changed significantly in four and a half years. 99 representation has dropped from 21%; 900s and 9000s are both up, from 49% and 7% respectively.

There seemed to be plenty of interest at the convention for the older Saabs - the two-stroke, V4 and Sonett models - and the newer 900s and 9000s. Conspicuously absent were 99s. There were several very interesting examples, including Gary Stotter's concours winning 99 Turbo and a very rare 1977 EMS/Turbo (one of the factory pre-production test cars, in need of restoration) owned by Rick Comes. But overall, 99s were few in number. The above list indicates that there are now more 9000 owners among the membership than 99 owners.

The 99 Turbo is, to my mind, one of the few collectible Saabs. It was the first successful use of a turbocharger in a non-sports car application. Turbocharging the four-cylinder engine helped Saab to enter the 1980's with a true sporting sedan and led to the very popular 900 Turbo, and later the 9000 Turbo. It also started a trend of turbocharging among other car manufacturers, and today virtually all have at least one turbo model. Because of Saab's introduction of turbocharging in the 99 fifteen years ago, many people immediately think "Turbo" when Saab is mentioned.

In the United States, the 99 Turbo was available for only one model year, 1978, and only as a hatchback. About 4,000 of them made it to the U.S. It continued to be sold in some European markets through 1980, and included two door sedans. The Saab Owners Club of Great Britain has a registry of 99 Turbos, numbering over 100.

Will the 99 ever see the popularity of the 96/95 or the Sonett, is it too mainstream to be considered a collectible Saab, or is it simply in that "too old to be driven, too new to be interesting" limbo?

Oh, the joys of running a business from your home. I figured the installation of a fax/modem/answering machine board on

the computer would make it easier to receive articles or news releases. What I hadn't counted on was it happening at all hours. About once a week I am awakened by the phone ringing at 3 or 4 am. I always answer it, then disconnect the phone because the fax board seldom picks up these nocturnal submissions (it doesn't like machines that send automatically).

The only alternative is to use someone else's machine, for a fee (difficult to justify when a phone call or note would receive the same response). The fax number we'll be using is 218-728-6307.

NINES continues to run about two months behind the cover date. The plan is to whittle away a few days each issue and get back on track within a year. Toward that end, there is a new name on the masthead.

Michelle Swanson will be handling office work and assisting in layout. Her training is in the graphic arts, but much of her work experience is clerical. It seemed like a good combination for the Saab Club.

Since the number of technical submissions have dwindled, I've been researching and writing more material myself, and on subjects with which I am most comfortable - history, competition, test drives, product evaluations and project cars (though there has been no time to work on projects this year). I sometimes travel to research a story, but when I do, I try to add several more potential stories. Most out-of-office trips are good for three or more.

I would still prefer to see more technical "how-to" tales from readers. Whether you pound it out on a computer or scribble it on a notepad, your fellow Saab owners will appreciate your experience.

I'd hate to have to resort to publishing photos of Viggen, my dog, to fill space.

Tim Winker
 Editor / Publisher

NINES

The SAAB Club Newsletter
2416 London Road, Unit 900
Duluth, MN 55812-2221

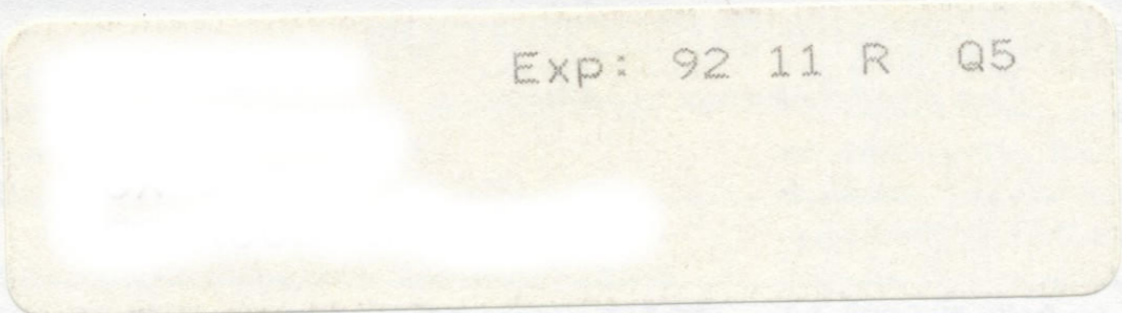

FIRST CLASS
U.S. POSTAGE
PAID
PERMIT NO. 1909
DULUTH, MINN.

Forwarding and
Address Correction Requested

August 1992

FIRST CLASS MAIL



SPECIALIZING IN PARTS & SERVICE FOR SAAB & VOLVO

OEM, OE & AFTERMARKET PARTS AVAILABLE
PARTS DISCOUNTS UP TO 50% OFF LIST PRICE

CALL FOR MONTHLY SPECIALS

SAAB

1800-32TROLL

VOLVO

INFORMATION & TECHNICAL ASSISTANCE 410 682-4688

MOST ORDERS SHIPPED WITHIN 24 HOURS / VISA, MASTERCARD & AMERICAN EXPRESS ACCEPTED

The SAAB Specialists

4535 S. Washington - Tacoma WA 98409
Open 8am-5:30pm, Monday-Friday



A Complete SAAB Service Center
Original Replacement Parts, New and Used
Factory Recognized Service
and Body and Fender Repair
206-474-0177



GOLDWING USED SAAB PARTS WAREHOUSE Nationwide Shipping UPS - COD

- Alternators
- Starters
- Axles
- Calipers
- Antennas
- Radios
- Wheels
- Tires
- Tail Lights
- Window Motors
- Rack-n-Pinions

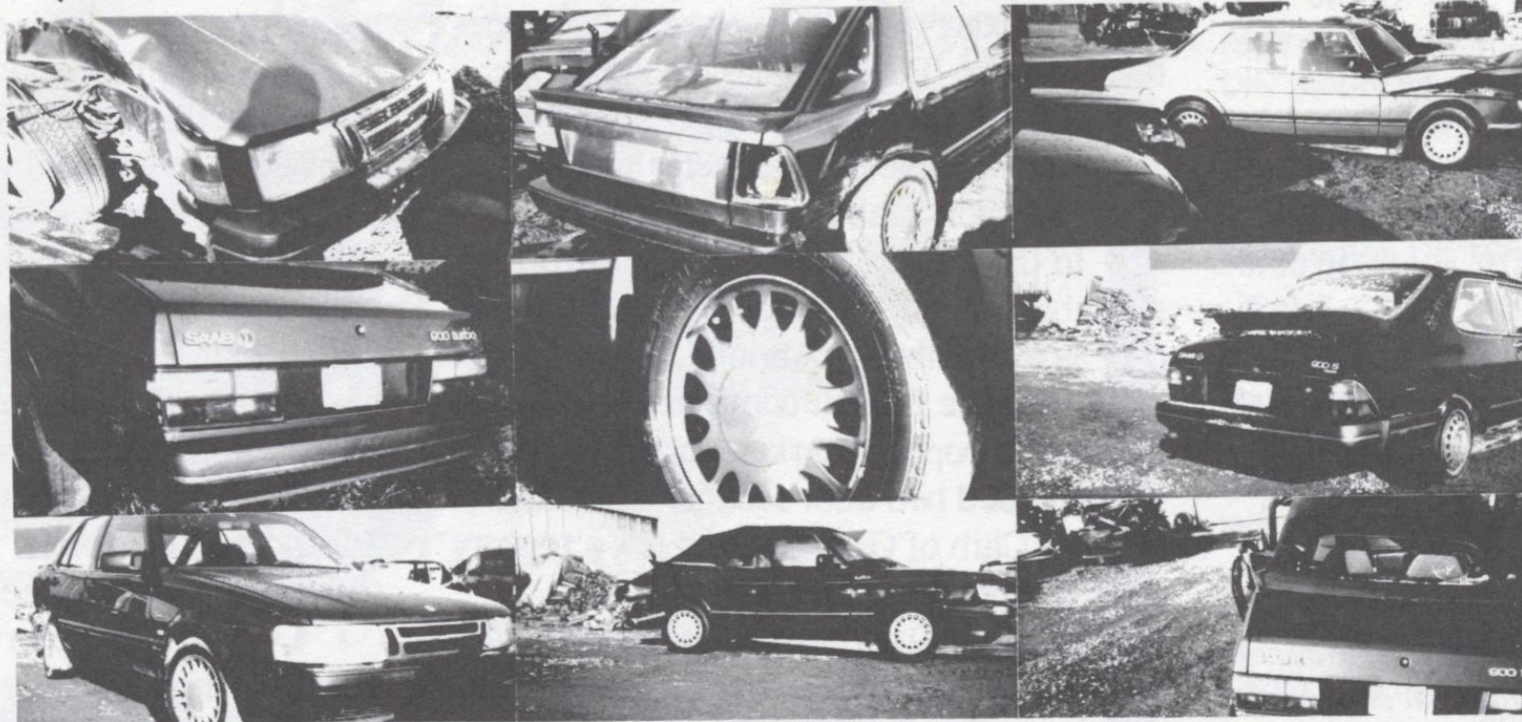

- Transmissions
- Engines
- Radiators
- Grills
- Fenders
- Turbos
- Bumpers
- Air Compressors
- Cyl. Hds.
- Seats

All parts Tested and Guaranteed, some Lifetime!
Over 75,000 Used Parts In Stock
We Specialize in 900 and 9000 Only

Call 1-800-SAAB137 or (315) 625-7969

Rt. 11 Hastings NY 13076