



# NINES

THE SAAB CLUB NEWSLETTER

\$2.25  
September  
1990  
no. 195



New name,  
new officers for  
Saab in U.S. pg. 10

NC '90 - Convention  
photos and results pg. 15

Ashcraft digs into Sonett  
wiper switches pg. 12

4 pages of Service Tips  
from Saab pg. 6

The Last Viggen pg. 11

Left: Barb and Andy Bittenbinder pose  
with their "Best of Show" '72 96-V4

Below: 93s, 96s, 97s, 99s, 900s  
and 9000s by the dozen





**"GOLDWING"  
SAAB**

**Our Only Business  
1-800-SAAB-137**

**Box 315 Rt. 11  
Hastings, NY 13076**

**Used Auto Parts  
Will Ship Anywhere**

## Regional Club News

### Calendar of Events

#### Delaware Valley SAAB Club

Sept. 9 - Family Picnic (rain date 9/16).  
3pm-? at Bill Jacobson's house.  
Hamburgers, hot dogs, crabs, sodas &  
chips provided by the club. Bring a  
covered dish or dessert for 8-10 people.  
Pat Bolmeyer, 302/994-6357.

#### Northern Illinois SAAB Club

Sept. 8 - Annual Picnic, 12 noon. Please call  
312/631-4476 for location and info.

#### Ohio SAAB Enthusiasts

Oct. 13 - Fall Family Gathering, Euclid Park  
clubhouse, E. 222nd St. & Lakeshore  
Blvd. Pete Rechnitzer, 216/243-1488.

#### SAAB Owners' Club of Canada, Inc.

Sept. 19 - Meeting, Topic: Automotive  
finishes  
Sept. 22 - Brake Clinic at Peter Shaw's  
house  
Oct. 20 - Maintenance Clinic at John Davies'  
house  
Grant Heaphy, 477-4039

#### Out of the Woodwork #10

Oct. 7 - Sports car meet. Scenic Round  
Valley Rec. area, Lebanon, NJ. SAAB  
Clubs invited to participate and display.  
Pre-registration required, \$10/car.  
Marq Ruben, 301/986-8679 evenings.

SAAB Club of North America  
2416 London Road, Unit 900  
Duluth, MN 55812-2221

218/ 724-1336, 9am - 6pm Mon - Sat  
Fax number: 218/ 728-6307  
(Head fax messages: Attn. SAAB Club)

NINES Editor & Publisher:  
Tim Winker

Membership / Business Manager  
Nancy Forsythe

NINES is published eleven times a year  
(monthly except August) as a service of the  
SAAB Club of North America. The SAAB  
Club is not affiliated with Saab-Scania of  
America, Inc. or Saab Automobile AB.

All material copyright 1990, SAAB Club  
of North America. Material may be repro-  
duced with proper credit to the author and to  
"NINES, the SAAB Club Newsletter". The  
opinions and views expressed in articles are  
not necessarily those of the SAAB Club and  
its newsletter, NINES.

Editorial contributions are welcome. All  
material submitted is assumed to be for  
publication unless clearly labeled other-  
wise. Double-spaced typewritten articles  
are preferred, but most anything is accept-  
able. We cannot answer every inquiry and  
reserve the right to edit materials submitted.

Those wishing to submit articles or letters  
on 5 1/4" IBM-formatted disks, please convert  
to ASCII text files (<filename>.TXT). Please  
include a printed hard copy, and a SASE if  
you want the disk returned.

CHANGE OF ADDRESS: Eight weeks  
notice is required for change of address.  
Please send new address and old address,  
including zip codes, to the SAAB Club at the  
address above.

RETURNED CHECKS: There will be a  
fee of \$10.00 charged for checks returned  
for any reason.

# SAAB



## SONETT

### RESTORATION & REPAIR

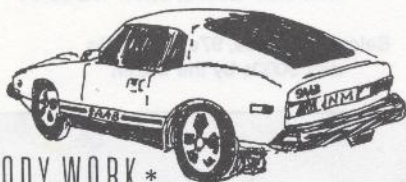

BODY WORK \*

MOTOR & TRANS. WORK \*

RUST REPAIR &

WELDING

# Nordic Motors

(617) 648-6050

The Central Penn SAAB Club has  
come up with their own commentary on  
the Saab/GM alliance. The familiar  
Swedish troll is pictured under the banner  
"Herr Bra-Skiftnyckel" -- in English, "Mr.  
Good-wrench". The club had the design  
made into a 3-inch embroidered patch  
that was for sale at the convention. Caps  
with the patch were also available.

Details on how to order can be had  
through: George Basehore  
477 E. Main Street  
Middletown, PA 17057.



## Letters to NINES

### Bike rack trouble

I have had several communications with Rhode Gear, the manufacturer of the Cycle Shuttle. [I wrote the company in September, 1988 regarding] the hatch of our '86 900S (one of our two SAABs) which was dented by the application (properly) of the Cycle Shuttle. After a wait of almost two years and after they requested and I provided photo documentation, an estimate for the repair, and the actual Shuttle itself, I received a letter which indicates that the problem was not with the Cycle Shuttle, but "was due to the fact that the trunk of your vehicle is not of a desirable density for any bicycle carrier."

I do not believe this to be true, but feel that it is appropriate that SAAB owners be aware that the use of this Cycle Shuttle may be detrimental to the hatch on the SAAB 900. The company obviously does not stand behind its product and blames one of the most strongly built automobiles for the problem which I encountered.

Alan I. Leibowitz, M.D.  
Paradise Valley, AZ

### Flawed, but still fun

Before relieving the shock I must have caused fellow 900 owners by saying my brand new 1990 Turbo was "flawless," (June issue) I want to thank Stephen Goldberger for correcting statements about how the "aging 900" is killing Saab sales. Sales figures periodically printed in NINES show that the 9000 is the true disaster. Saab dealer personnel readily concede this. The 900, in fact, has weathered a downturn in the auto business quite remarkably for its age. As Stephen correctly noted, the 900 has prevented a cataclysm for U.S. Saab dealers.

Regarding my "flawless" 900 Turbo, no sooner had I written that praise than my SRS (airbag) malfunction light came on. There was no malfunction, but it took several trips to the dealer to (hopefully) fix it for good. This problem has reportedly hit a number of new 900s. Next came an air conditioner switch that usually wouldn't engage unless I held it in place for anywhere

from one to ten minutes -- pretty tricky work with a 5-speed; and all of it right during a monstrous heat wave. Finally, the cruise control stopped working; a bad sensor and leaking vacuum switch.

Add to this a hatch latch that was tight and sometimes stuck (just push down on the hatch when that happens) when new, plus a very recent idle roughness problem (the dealer suggested humidity; I'm checking), and you have the true appraisal of my new 900T. So, ironically, it turns out that this car had more problems than other SAABs I've owned. As always, the problems were relatively insignificant and could not at all detract from the greatness of the car, explaining why I've owned five new SAABs in fifteen years. Still, I do wish Saab could finally improve quality control.

But don't look for new partner GM to help in that area. A buyer of a new Vauxhall Carlton told Britain's AutoCar magazine recently about a laundry list of horrors including parts coming off the dash and breaking mirrors.

Which reminds me, the Saab dealers can sell GM's new Calibra if they want. But don't ever look for me to want one. I'd sooner have a 1974 Sonett, for all its faults, to rebuild, than that listless handler from Opel.

Bill Bartman  
Alexandria, VA

### 96 daily driver

Here is my renewal for another year. As a 96 owner this is mostly a vote in favor of the continuation of Mr. Ashcraft's contributions.

I realize that everything goes up, and that you are not getting wealthy off this venture, but I do feel also that a serious attempt must be made to control costs and keep the renewal rate at \$20.

As with many readers the thing which most bothered me last year were your comments about 96 owners, maybe because there was a bit of truth in them. I drive my 96 often, during the winter months a daily 100 miles. I have driven it across the country many times, one time in weather so cold that when I got off the pass and down into a Wyoming town, I found the temperature at 33° below! I have driven it into the outback in southern Utah into places where

you see another vehicle maybe once a week if you are lucky. I'm sure other readers have similar experiences. So you can see why we are touchy when someone disparages the reliability of older vehicles. As for maintenance, I have never been wealthy but I do what I can, mostly with used parts from my other SAABs.

Keep up the good work, thanks for another year.

Greg St. George  
Missoula, MT

### Another unhappy customer

While it has been on my mind to write for some time, a letter in the July/August issue from a former Saab owner in New Jersey gave me the impetus I needed. He sold his two Saabs because dealer service in central New Jersey "is terrible". He mentioned two dealerships; I'd like to add to that list. Sports and Specialists in Trenton is also terrible.

My husband and I have started driving to Pennsylvania for service. We have taken both our Saabs to Parrformance in Lititz, PA, and have been very happy with the quality and price (\$30/hour labor compared to \$48-\$50 at New Jersey SAAB dealers). In fact, we highly recommend Parrformance. However, the problem for us is that Parrformance is 125 miles away, obviously not the most convenient!

We're looking for a place to take our SAABs for service that does quality work at reasonable rates in central New Jersey. (An impossible search, maybe?) Does anyone in New Jersey have any suggestions to pass along?

Kathy Naymola  
Plainsboro, NJ

### Have you tried Trident?

Enclosed is some information on a very interesting product called the Trident. It is a radar detector with a built-in police scanner and a CB receiver. Has anyone in the Club tried this unit, and is it worth the cost?

Larry Swanson  
786 Baylor Rd.  
Rochester Hills, MI 48309

# Bel-Kirk SAAB

Our Specialty  
Since 1980

Award Winning  
Parts Department  
1987-88-89

USA 800-828-6812  
FAX 206-828-4272  
Local 206-828-4511

## SAAB



99 & 900

RESTORATION & REPAIR

\$30 hourly rate!

(617)  
648-6050

Nordic  
Motors

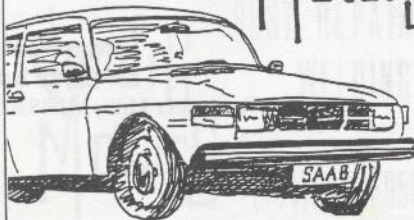

### Saab wins Baja, again!

Remember when a Saab 96 driven by Ingvar Lindqvist won the Baja 1000 back in the late '60s, with Erik Carlsson competing in a similarly prepared V4? It's happened again, only now the 96 is a 20-year-old machine up against factory sponsored teams.

Arne Gunnarsson and Greg Moser took the Class 6 win in this year's Baja 500, driving a 1970 96-V4. Arne reported their only problems were a flash flood halfway through that held them up for half an hour, and a blown brake hose near the end.

Their competition included five factory-supported "utility sedans": two



Photo by Don Phillips, Culver City, CA

Jeep Cherokees, a Ford Bronco, a GMC Jimmy, and a Chevy Blazer.

Team 96 is only running selected off road races this year due to lack of sponsorship. Their next race will be the Baja 1000 in November.

### New Sports Car Announced!

Last time, it was mentioned that The Factory had set a six model range for the new model year. Coily only five were revealed. The sixth, the new sports car, was left for this occasion. Note that is not another sports model, but rather a new model based upon our beloved Monte Carlo.

The recent takeover of the floundering auto giant has undoubtedly made this new model possible. The infamous big plastic pig was a great and instant embarrassment to The Factory and had to be quickly dispatched. Within hours of the takeover, the St. Louis factory was idled and a long thought of plan was put into action. Apparently The Factory had been considering a sports car for a number of years but did not have the manufacturing capacity for it. Remember the demand for the 95/96 has been running in excess of 10,000 cars per year for some time now. The post-takeover death of the big plastic pig freed up the space and the workers to produce such an exciting model.

Its name? Sonneett.

As you already realise, in English the name is beautiful onomatopoeia, but it is also a multilingual name. The implication is that the new Sonneett might well be exported, putting St. Louis among the exotic car capitals of the world.

According to The Source, the sports car will have a fiberglass body (due to the St. Louis plant's equipment) and the basic technical specifications of the Monte Carlo Turbo, Three by Three by Three. That is to say, the Mighty Three engine, triple turbo, triple intercooler, special three carbs, three speed transmission and three-speed axle. Befitting its place, the Sonneett is expected to get two tone all vinyl interiors and as well, the top of the range radio. An instant classic no doubt.

It is truly incredible how The Factory continues to stun the automotive world with this flow of news, technological innovation and new or improved products.

Until next time, best wishes.

*Simon Du Stroke*

## Doktor Nio's SAAB Klinik

Submit your questions with as complete information on the problem as possible, also giving the year and model of SAAB. Problems of general interest will be answered here. No requests for personal replies please. Questions which would require modification of, or would defeat Federally required emissions systems will not be answered. For a proper diagnosis, it is recommended that you contact an authorized SAAB dealer or repair shop.

Send your questions to: SAAB KLINIK, 2416 London Road, Unit 900, Duluth, MN 55812-2221

I am the owner of an '87 9000S with 56,000 miles. Is there any way to reprogram the automatic climate control so it doesn't turn on when the car is started? Is it possible to convert to the manual system from a new 9000S?

I'd like to convert my steel sunroof to the glass roof found on the 9000 Turbo. Can it be done?

For the past 20,000 miles, the "Check Engine" light comes on in intervals of four flashes. The problem is intermittent, and only seems to happen when I let the engine revs fall (as when coasting to a stoplight). Am I damaging the engine? Should I be concerned with the "idiot light"? The dealer has been unable to locate a problem.

Any suggestions for keeping the leather seats looking good? My car is exposed daily to bright sunshine.

Barry Oppenheim

*The Automatic Climate Control can be over ridden by selecting economy or manually pressing any of the desired air distribution or heat vent controls. The system is designed to be hands free operating for the driver with other things on his mind, but if you wish to select your combination of air and where it goes, the system will gladly respond to your every button push. Going back to total manual system would only have you doing more twisting and turning of knobs. Learn your ACC system and let it do the work.*

*The glass sunroof is a different unit than the sliding steel roof. I am sure if the steel roof could be updated to the glass unit, Saab would be offering it as an option.*

*A "Check Engine" light flashing four times in intervals denotes a problem with the knock sensor in the EZK ignition system. The problem could lie in the sensor or the wiring. My guess would be a pinched knock sensor line or poor connection at the sensor plug. Also check for pulled pins in the plug body itself. Don't ignore that light! It means your ignition system is not working the way it was designed to, and you could be doing unseen and unheard damage.*

*Treat the leather faces of your seats often with a good leather conditioner. I have used Lexol with good success. It has*

*separate conditioner and cleaner. Keep the leather soft and supple with the conditioner and use cleaner when necessary.*

My everyday '74 SAAB 99LE has 147,000 miles on it, and I love its comfort, safety, and superior handling. However, during warm-up it idles fast, then slow, repeatedly. Also, when headlights or some other electric accessory is switched on, the engine almost dies, then recovers. I've replaced the coil, ballast, relays, condenser, points (several times), and checked the timing and point gap. Should I look for a bad ground or short, or is there an obvious solution?

Bob Seath  
Coon Rapids, MN

*A cycling idle during warm-up on an early electronic injected engine denotes a too rich cold mixture. The solution may be as easy as leaning out the base mixture setting on the brain (turning counter-clockwise). More likely it's a multi-faceted problem. I've seen many problems with the auxiliary air regulator sticking and the hoses to it drying out and cracking. I would recommend replacement if in any doubt of its function. Also check the adjustment of the throttle switch, values of the coolant temp sensor, and integrity of the manifold pressure transducer and its hose. For proper set up of the early electronic injection systems, look for the reprint of the articles by John Fog in the March 1990 issue of NINES.*

I own a 1983 900 Turbo with 60,000 miles. I had the complete 60,000 mile checkup according to the owner's manual at a Saab dealer. This included a complete tuneup with all Saab parts.

But I still have one major problem. The engine cuts out sometimes. It's like turning the ignition key off and on, and the tach needle flips up and down. It does this about three times within each hour of driving time. The Saab dealer recommended an Ignition Amplifier or a \$7 part in the distributor.

Dave Hixon  
California, PA

*When electrical gremlins start stealing*

*electrons at odd times in SAAB automobiles I will look at the ignition system very closely. From experience, I have seen more than one distributor advance system come apart and scatter metal fragments throughout the distributor, causing the Hall effect transducer periodic fits. I have also seen the ignition amplifiers exhibit very bizarre patterns of momentary failure or voltage loss during heavy draw. If nothing looks wrong in the distributor, try to get an ignition amplifier "on loan" to try. It sounds like you would know very soon if this was the solution.*

*Did they change spark plug wires at the 60k maintenance? A bad coil wire can give the same symptoms.*

I like my 1987 9000S, but I think I have a potential problem - engine running hot. At moderate outside temperature (75°F), the oil temperature runs 210°F with the in-dash water temp gauge 3/4 towards the red. The radiator fan works, but when I turn the engine off and the gauges read as above, it doesn't cut in until the engine has been off for about 30 seconds. Should I be concerned?

James Leonard  
Springfield, VA

*Have you ever had your thermostat changed? A replacement thermostat with an 88°C opening rating should run your temperature gauge close to the middle. Also have your technician check your thermo-fan switch while reading the actual coolant temperature in the expansion tank. The thermo-fan switches, stock in the car, should trigger at around 190°F.*

What is the best coolant to use, and where can you buy it other than the Saab dealership?

William Seethaler  
Pittsburgh, PA

*The best coolant is one that has aluminum guard protection in it. All Saab cylinder heads are aluminum (not including Ford V4) and will quickly deteriorate without the protection. And always change your coolant every 15,000 miles or once a year!*

# SERVICE SUBJECTS



## FROM SAAB

### Consumer Information/Tips 4/90 **Saab-Alpine Alarm - 900**

The Saab-Alpine accessory alarm for 1988-on 900 models contains two remote transmitters for arming and disarming the system. These transmitters are powered by Lithium, type CR 2025 batteries. When diagnosing a complaint of a non-operating alarm system or reduced length ability when using the transmitters, be sure not to overlook the condition of the batteries.

### **Convertible Top Cover Damage**

Rough edges on the first and second side rails of the convertible top mechanism may damage the top cover when folded (see illustration). This is a different type of damage than addressed in Service Campaign 313.

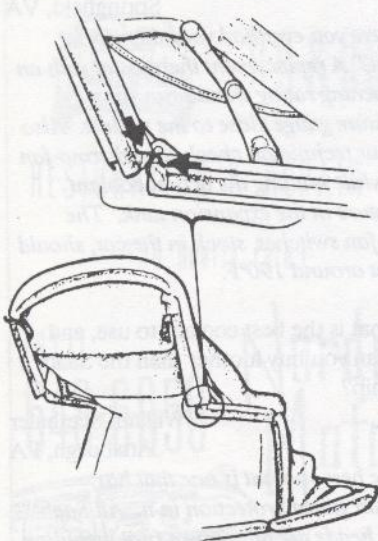

Beginning with VIN K7033020 the production line has introduced an inspection procedure to correct any rough edges at

these points.

If any rough edges are found, they can be smoothed with a file and the bare metal edges touched up with paint.

### **Coolant Formulation Change**

A change to the Saab approved coolant formulation has been made which offers improved corrosion protection. The coolant is manufactured by BASF and offers excellent corrosion protection properties for all elements of the cooling system including the radiator, cylinder head and other key components. The previous formula, G105, has been replaced by G48.

### **Damaging the LH Control Unit - 900, 9000**

On 900 and 9000 models with the LH 2.4 fuel injection system, damage to the LH ECU is possible if the connector to the control unit is disconnected before the LH main system relay had de-energized.

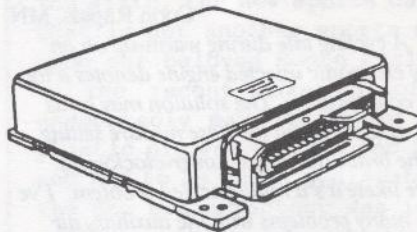

After the ignition has been switched off, it takes approximately 32 seconds before the system relay de-energizes. Always wait at least 40 seconds before disconnecting the control unit connector.

### **Rubber Floor Mats - 9000**

When installing Saab rubber floor mats in a 9000, make sure the mounting kit that is included with each set of mats is installed properly. Installation instructions are provided with each kit. The mounting kit will prevent the driver's mat from sliding forward and interfering with pedal travel. Note the following points regarding installation:

- Cut the protruding flap off the back edge of the mat before installing the mat in the car (step 1 of the installation instructions).
- Use an awl rather than a knife to make the hole in the original carpet when installing the lower securing screw (step 4 of the installation instructions). Using a knife will make the hole too large and will not hold the mat securing

screw well.

Additional mat securing kits are also available separately under part number 02 44 707.

### **Oil Additives**

Extra oil additives are not recommended! Such additives are not necessary to realize the proper performance and reliability of Saab engines. In turbocharger applications, additive usage increases the risk of coking the turbocharger bearings.

### **Drive-Belt Tension - 900**

The performance and life of the drive belts for the alternator, power steering pump and the AC compressor are dependent on the belts being correctly tensioned.

A new drive belt will lose its tension fairly quickly after being installed. When the belt becomes slack, it will start to slip as there is not enough tension to transmit the required power. A slipping belt will rapidly become worn smooth and in time will eventually squeal. Subsequent belt failure is then not far off.

Therefore, it is essential that belts be properly tensioned. This holds true for installing new belts as well as checking the tension of existing belts at the specified service intervals.

The belt tension must be measured at three points:

1. Between the alternator and the water pump.
2. Between the AC compressor and the idler wheel pulley.
3. Between the crankshaft pulley and the power steering pump.

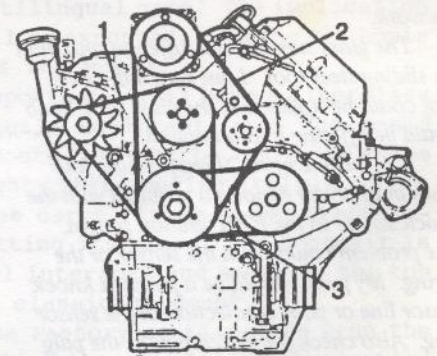

Points 1 and 2 are measured from above and point 3 from underneath the car.

#### Note:

- Always use a belt-tensioning gauge.
- Measure the tension when the belt is

| Belt           |                      | N (lbf)  |                     |                      |
|----------------|----------------------|----------|---------------------|----------------------|
|                |                      | Minimum  | After Adjusting     | New Belt             |
| Power Steering |                      | 220 (50) | 310 ±20<br>(70 ±5)  | 445 ±45<br>(100 ±10) |
| AC Compressor  |                      | 245 (55) | 355 ±20<br>(80 ±5)  | 535 ±45<br>(120 ±10) |
| Alternator     | Measuring one belt   | 200 (45) | 310 ±20<br>(70 ±5)  | 535 ±45<br>(120 ±10) |
|                | Measuring both belts | 420 (95) | 645 ±20<br>(145 ±5) |                      |

#### Drive belt tension specifications, 900 16-valve

- cold. This means the engine must have been switched off for at least half an hour at room temperature with the hood open.
- When tensioning an existing belt, do not slacken the belt. Undo the set nut and tighten the adjusting bolt as required.
  - The crankshaft must not be rotated before the tension of a newly fitted belt has been measured.
  - For a belt to be considered new, it must not have been run for more than 30 seconds.
  - After a new belt has been installed, it must be retensioned after a maximum running of 600 miles. If an old belt is refitted, retensioning after a run-in period is not necessary.
  - Before tensioning or replacing a drive belt, make all necessary adjustments to the pulleys, brackets and mountings for the engine auxiliaries.

#### Consumer Information/Tips - 7/90

##### Alternator Keys - 900, 9000

Since mid-1987, starting with VIN's H2008687-, H3006972, and H7013655-, alternators have not used a key between the pulley and the rotor shaft. This is true for both the 80 amp and 115 amp alternators.

The pulley is secured solely by means of the pulley nut. Tightening torque for this nut is 34-39 Nm (25-29 ft lbs.).

Saab Service Information updates are provided to NINES as a courtesy to Saab owners by Daniel L. David, Director, Service and Technical, and Sten O. Helling, President of Saab Cars USA, Inc.

#### New Engine Oil Drain Plug and Sealing Washer - 900

A new engine oil drain plug and new sealing washer have been introduced into 1990 900 manual gearbox production as from gearbox serial numbers A07249- and B03790-. The new drain plug, P/N 87 28 065, can be identified by its 19mm hex head and yellow chromate color. The plug has a more rigid sealing flange than the old style plug but retains the same M14 x 1.5mm thread pitch.

The new sealing washer, P/N 87 28 057, is now made of steel and has a rubber ring molded around its external circumference for improved sealing characteristics. The old style copper washer should not be used together with the new drain plug.

##### Caution.

The torque specification for the new drain plug has not changed. Engine oil drain plugs should only be tightened to 34 ±5 Nm (25 ±3 lb. ft.) using a torque wrench. Do not overtighten!

##### Overtightening damage

Overtightening of the drain plug could result in cracks and oil leaks at the oil drain. Main case failures resulting from the overtightening will not be considered as a warrantable item.

Repair of a cracked main case using epoxy compounds or welding should not be attempted. Replacement of the main case is the only method that is approved.

##### Motor Mounts

On 900 models with the solid rubber mounts (non-hydraulic), excessive engine vibrations can be transmitted through the chassis if the mount is "bad". The mounts

can be checked in the car and should be inspected for the following two points:

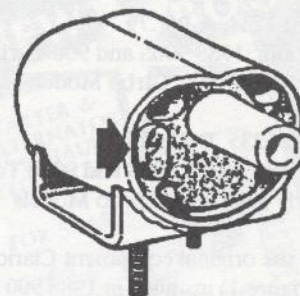

Check if the rubber bonding has come away from the mounting body.

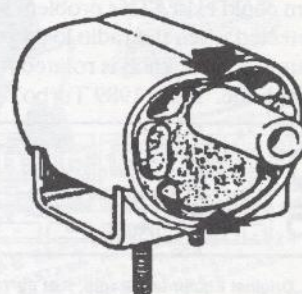

Check that there is clearance between the rubber and the mounting body at both top and bottom with the engine installed.

## Exclusive

# SAAB Parts Center

The area's most extensive  
inventory at

competitive discounts  
(215) 886-8660

Free delivery locally  
or Standard UPS

# SAAB → VICTOR

Exclusively SAAB since 1958  
1125-35 Easton Road • Abington, PA 19001  
Facsimile (215) 572-5030

## Clarion Radio Volume Control Fault

S.I. 04/90-1234, A-9/P.79

Application: 1988 900S and 900 Turbo,  
Early 1989 900 Turbo Models

S.I. 04/90-1235, B-9/P.16

Application: 1988 9000S and 9000 Turbo,  
Early 1989 9000 Turbo Models

On the original equipment Clarion radio (Figure 1) installed in 1988 900 S, 9000 S, 900 Turbo, and 9000 Turbo models (original part number 02 73 672), a power and/or listening gap in the volume control mechanism could exist. This problem is usually detected when the radio loses power as the volume control knob is rotated for increased volume. Early 1989 Turbo

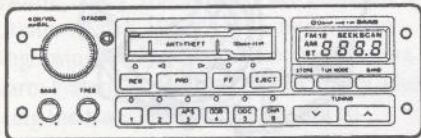

Figure 1. Original Equipment Radio, P/N 02 73 672 models were equipped with the same radio and may be subject to this problem also.

Customer complaints for this problem could be received as:

- Intermittent loss of power as the volume control is rotated
- Cassette ejecting while rotating the volume control knob
- Radio goes dead when increasing the volume.

As from November 1989, all radios in the Clarion exchange bank, and all radios that have subsequently been received back into the exchange bank from dealers, have had the volume control replaced with an improved version regardless of any fault found. This has been done by Clarion to ensure that there is no risk of this problem occurring on exchange units and to eliminate repeat repair problems.

Should a customer with a radio subject to this problem call with a complaint as described above, the dealer should order an exchange unit in advance of the service appointment to replace the radio. After replacing the radio in the customer's car, the dealer should return the core to Clarion promptly. The success of any exchange program is dependent upon the timely return of the core.

## Motion Detector Sensitivity Programming for the 9000 O.E. Alarm System

Application: 9000 1989, VIN's thru -L1007891, -L2005893 with the early type alarm module. See next page for procedure for revised module.

The following sequence will allow the motion detector to be tested and programmed to a level of sensitivity greater or less than the factory setting of 3 units. The module is designed with a possible 240 adjustment increments. 1 unit is the most sensitive, 240 units the least sensitive.

- Open the front windows, close all doors, trunk and hood.
- Remove and replace fuse 19 (fuse 22 for very early 1989 production), the LED will flash every four seconds.
- Turn the door key from neutral to unlocked twice, quickly (Figure 1).

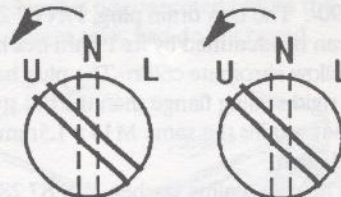

Figure 1: Turn to unlock twice, quickly

- After ten seconds, the LED will start to flash twice per second signifying that the motion detector is in the sensitivity test and adjustment mode.

Saab recommends that the motion detector sensitivity level be raised from the factory set default level of 3 units to a level between 30 and 50 units (making the unit less sensitive) in order to minimize the risk of false alarms. The driving environment of certain vehicles may require adjustments to more sensitive or less sensitive motion detector settings, but between 30-50 units should be considered the basic level.

To check the sensitivity of the motion detector, a consistent means of producing a "shock" or "blow" to the vehicle is required. This can be achieved by pulling back on the drivers outside rear view mirror to a position just before it locks and letting it snap back into position. This method of testing the sensitivity should approximate a setting of between 30 and 50 units (each vehicle and/or ECU may differ slightly).

- To decrease sensitivity, turn the door key to the locked position, hold for two seconds then release (figure 2). Each



Figure 2: Turn to lock and hold for 2 seconds.

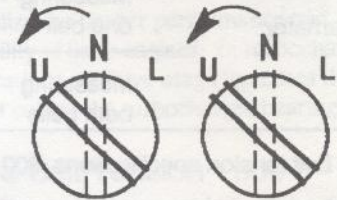

Figure 3: Turn to unlock twice, quickly, to program sensitivity setting into memory.

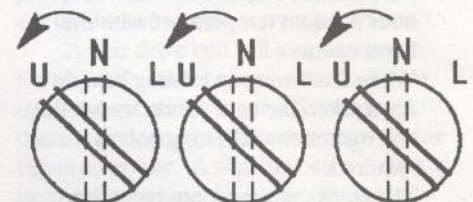

Figure 4: Turn to unlock three times within two seconds

repetition of this cycle will decrease sensitivity by one unit.

- To increase sensitivity, turn the door key to the unlocked position, hold for two seconds then release. Each repetition of this cycle will increase sensitivity by one unit.
- Test and repeat until the desired sensitivity setting is obtained.
- Turn the door key quickly from the neutral to the unlocked position two times to program the sensitivity setting into memory (Figure 3). Wait, the LED will now flash once every four seconds.
- Next, turn the door key from neutral to the unlocked position three times within two seconds (Figure 4). The LED will stop flashing.
- Open and then close the driver's door and lock it. After the interior light delay cycles off the alarm will go through its arming cycle and the LED should flash once every second.
- Confirm the memory setting of the motion detector by "snapping" the mirror or whatever means that was used to set the sensitivity.

**NOTE:** Failure to follow these steps exactly will switch the alarm back to the factory preset sensitivity level.



Application: L1007892-, L2005894-, 9000 Models, plus earlier models that have sticker affixed to the LF wheel housing stating that revised alarm module, Saab P/N 40 92 037, has been installed.

The following sequence will allow the motion detector to be tested and programmed to a level of sensitivity greater or less than the factory setting of 12 units (out of a possible 240 units, with 1 being the most sensitive).

- Open the front windows, close all doors, trunk and hood.
- Remove and replace fuse 19. The LED will flash once every four seconds.
- Turn the door key from neutral to the unlocked position (Figure 5) and hold it there until the siren chirps and the parking lights flash (at least 10 seconds), then release the key.



Figure 5: Turn to unlock and hold 10 seconds

- The LED will flash once per second for approximately ten seconds.
- After ten seconds the LED will start to flash twice per second signifying that the motion detector is in the sensitivity test and adjustment mode.

Saab recommends that the motion detector sensitivity level be raised from the factory set default level of 12 units to 20 units (making the detector less sensitive) in order to minimize the risk of false alarms. The driving environment of certain vehicles may require adjustments to more sensitive or less sensitive motion detector settings, but 20 units should be considered the basic level.

To check the sensitivity of the motion detector, a consistent means of producing a "shock" or "blow" to the vehicle is required. This can be achieved by pulling back on the drivers outside rear view mirror to a position just before it locks and letting it snap back into position. This method of testing the sensitivity should approximate a setting of 20 units (each vehicle and/or ECU may differ slightly).

- To decrease sensitivity, turn the door key to the locked position, hold for two seconds then release (Figure 6). Each repetition of this cycle will decrease



Figure 6: To decrease sensitivity, turn to lock, hold for 2 seconds.

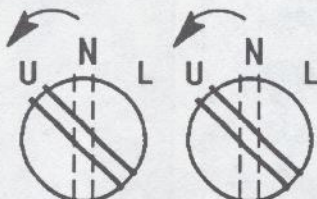

Figure 7: Turn to unlock twice, quickly, to program sensitivity setting into memory.

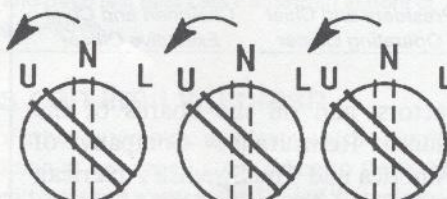

Figure 8: Turn to unlock three times within two seconds.

- sensitivity by one unit.
- To increase sensitivity, turn the door key to the unlocked position, hold for two seconds then release. Each repetition of this cycle will increase sensitivity by one unit.
- Test and repeat until the desired sensitivity setting is obtained.
- Turn the door key quickly from the neutral to the unlocked position two times to program the sensitivity setting into memory (Figure 7). Wait, the LED will now flash once every four seconds.
- Next, turn the door key from neutral to the unlocked position three times within two seconds (Figure 8). The LED will stop flashing.
- Open and then close the driver's door and lock it. After the interior light delay cycles off the alarm will go through its arming cycle and the LED should flash once every second.
- Confirm the memory setting of the motion detector by "snapping" the mirror or whatever means that was used to set the sensitivity.

NOTE: Failure to follow these steps exactly will switch the alarm back to the factory preset sensitivity level.

# NEW BOOKS!

**STARTER & ALTERNATOR OVERHAUL TECHNIQUES**

FOR SAAB

by Jack Ashcraft

SHOWS YOU HOW-TO-DO-IT STEP-BY-STEP!  
COVERS '65-'90 SAABS, GOES BEYOND THE SHOP MANUAL! \$20 Postpaid \$22 Postpaid Overseas  
USA, Canada

**SAAB ELECTRICS FOR EVERYONE**  
UNDERSTAND, REPAIR YOUR SAAB 95,96,97,  
99,900 WIRING! 70 PAGES OF  
HOW-TO-DO-IT! \$40 Postpaid \$44 Postpaid Overseas  
USA, Canada

**SAAB SOURCES**  
GIANT INTERCHANGE MANUAL FOR 95,  
96,97, PARTS NUMBERS, SPECS TORQUES,  
SPCL PARTS CATALOG, MORE! 40 PAGES.  
\$15 Postpaid \$17 Postpaid Overseas  
USA, Canada

**DREAMS & DETAILS, 30 YEARS WITH SAABS**  
48 page coffee table book on how Saab design might have been. NEAT BOOK!  
\$24 Postpaid, \$26 Postpaid Overseas  
USA, Canada

**NOW AVAILABLE!**

**V4 HIGH PERFORMANCE 2-BARREL INTAKE MANIFOLDS!**

**FREE CATALOG!**

**JACK ASHCRAFT AUTOMOTIVE DESIGN**

**503-779-0731**

2201 Woodlawn Drive  
Medford, OR 97504

**SAAB NEWS**

# New name, new president for U.S. Saab operations

Saab-Scania of America, Inc., distributor for Saab Automobile AB in the United States, has been redesignated **Saab Cars USA, Inc.** The change took effect August 15, 1990.

In keeping with the parent company's mission to design, engineer, and produce unique Swedish cars which inspire pride and commitment, the renaming of the American importer and distributor more accurately describes Saab's business function in the United States and its role in serving its 363 dealers nationwide.

Since the establishment of the 50/50 partnership between Saab-Scania AB and General Motors (Europe) AG, the Scania Truck Division recently created its own U.S. sales and marketing operation in Orange, Connecticut, known as Scania USA, Inc.

Robert J. Sinclair, 58, who served as president of Saab-Scania of America, Inc. since 1979, has been named chairman and chief executive officer of Saab Cars USA, Inc. In this capacity he is responsible for the company's overall organizational management and will direct all legal and public relations functions, along with U.S. market liaison activities with the parent company.

Sinclair serves as chairman of the American corporation's Board of Di-



**Sten O. Helling**  
President and Chief Operating Officer

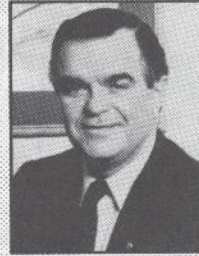

**Robert J. Sinclair**  
Chairman and Chief Executive Officer

rectors, and on the boards of the Hansa Reinsurance Company of America and The Swedish American Chamber of Commerce. He is a recipient of the Commander of the Polar Star, the highest honor bestowed to persons other than heads of State for economic, cultural, or academic contribution to Sweden.

Sten O. Helling, 52, has been named president and chief operating officer of Saab Cars USA, Inc. and is responsible for all car sales, marketing, planning, service and parts functions in the United States. Additionally, all financial, human resources, and information systems activities will report directly to him.

During the last year, Helling served as a sales and marketing consultant for the U.S. corporation. Prior to that, he was executive vice president for Saab-Scania of America, Inc.

## New Saab sales improve

The folks at Saab Cars USA, Inc. are hoping the July sales figures are an indication of better times ahead. Though the total sales of new Saabs were down slightly from July of last year, they were not running as far behind as those of most other European manufacturers. 3632 new Saabs were delivered in July, as opposed to 3663 during July, 1989. Total year-to-date sales through July are 16,881; 1989 YTD was 19,855.

Stephen Rossi, Manager of Public Relations for Saab Cars USA, Inc., said several factors were involved in the improved sales. One was the aggressive new marketing program, one facet of which is the new advertising campaign -- "We don't make compromises. We make Saabs."

"We were very quick to respond to our dealers' needs by providing a factory-to-dealer incentive program which allowed them to position and merchandise the cars they had as effectively as possible," Rossi added.

"We look forward to running through the remainder of the '90 model year according to our existing volume plan."

| Model                   | June '90    | July '90    |
|-------------------------|-------------|-------------|
| 900                     | 589         | 668         |
| 900S                    | 823         | 1158        |
| 900 Turbo               | 735         | 776         |
| 9000CD                  | 156         | 230         |
| 9000S                   | 216         | 313         |
| 9000 CD Turbo           | 136         | 259         |
| 9000 Turbo 5dr          | 126         | 199         |
| IDS sales               | 18          | 29          |
|                         | 2799        | 3632        |
| <b>Total 900 sales</b>  | <b>2147</b> | <b>2602</b> |
| <b>Total 9000 sales</b> | <b>634</b>  | <b>1001</b> |

## Saab shows improvement in Power survey

Luxury cars dominate the J.D. Power and Associates' Car Sales Satisfaction Index. Saab was 11th on the list, ahead of Toyota, Honda, Nissan, Porsche, and America's Big Three -- Chrysler, Ford and Chevrolet.

The survey measures consumers' perception of quality at the time of sale. Mercedes ranked first in the survey and in initial product quality, one of the three areas that comprise the total Sales Satisfaction Index. Saab placed first in delivery, while Infiniti was highest in salesperson performance, the most heavily weighted part of the index.

Saab's rating was 113, up 11 points from 1989. The industry average was 109 points.

The top five were: Mercedes Benz, Infiniti, Cadillac, Lexus, and Buick.

**ZYMoL!!**

**ANNOUNCEMENT**

**ZYMoL!!**

Because of the fantastic reception you gave ZYMoL at the convention, we have become distributors for their entire line! **We can now supply all ZYMoL products, including the special SAAB wax**, so you can enjoy the same fantastic results. Please call or write for more information, or to get the very best car care products ever! **Your SAAB deserves it.**

**GROUP 6 PERFORMANCE**

**4961 N. Calle Tobosa Tucson, AZ 85749 (602) 749-1809**



Viggen Program Manager, Sune Andersson (left) and Saab test pilot Lars Rådeström in front of the last Viggen off the production line in Linköping, Sweden.

## Proper use of head restraints can limit whiplash

Whiplash injuries are a frequent outcome of urban automobile accidents, which automotive experts say usually involve a rear-end collision at low speed. According to the latest statistics, there are more than four-million rear-end collisions a year in the United States; more than one third of all automobile accidents. As a result, roughly five million doctor visits are made yearly for diagnosis and treatment of neck pain.

While not a medical term, "whiplash" refers to the neck injury caused by a sudden jerking backward and forward of the head during an automobile accident. The medical term for the resulting trauma is "cervical sprain", which entails trauma to a joint plus injury to ligaments.

Saab, the safety-conscious automaker of Swedish-built 9000 and 900 passenger cars, realizes that whiplash injuries have become a common accident hazard and has thus expended substantial engineering resources making sure its seats are orthopedically sound and its passengers remain comfortable and safe.

Saab's careful attention to designing safety systems which optimize passengers' well-being is recognized in the recently-published *The Whiplash Handbook\** -- the first book of its kind dedicated to improving the understanding of the whiplash injury. In the handbook, Saab is the only automaker cited for having excellent head restraint properties to reduce the likelihood of whiplash. Saab's adjustable high back seats are praised because they provide good protection while not restricting rear vision.

Saab is also mentioned as one of the few car companies that reminds customers in its owner's manuals that the head restraint should be adjusted to bolster the back of the head, not the neck, in order to offer effective protection against whiplash injuries. Saab also recommends that a seat back which is slightly reclined, instead of positioned upright, will improve the occupants' chances of avoiding a neck injury in a rear collision.

Long before head restraints became mandatory in 1969, Saab began utilizing head supports in 1958 in its high-performance GT 750 model. The Swedish automaker realized that in a rear-end collision, the seat must effectively arrest the backward movement of the occupant's body and head. The backward tilt of the head is particularly critical, since the neck vertebrae could sustain serious injuries if the backward tilt were to exceed 120 degrees.

Today, Saab's head restraints consist of foam material, molded around a resilient backing plate, which arrest the neck and minimize the risk of injury to the neck vertebrae in the event of a collision. The height of Saab head restraints can be adjusted in several settings, which span about two inches. Saab seats are also anatomically correct and have a sufficiently wide range of settings to ensure that they will be practical and comfortable. To further ensure driver comfort, Saab front seats are additionally equipped with electric heating elements as standard equipment.

\*The Whiplash Handbook, 1989, was written by Monique B. Harriton with a Foreword by Ruth Jackson, M.D., F.A.C.S., and was published by Charles C Thomas, 2600 South First Street, Springfield, Illinois.

## The Last Viggen

The last Saab 37 Viggen jet fighter off the Saab production line was handed over to the Swedish Air Force at the end of June.

Saab-Scania President Georg Karnsund was the first speaker at the occasion:

"Development work on the Viggen started here at the Saab Aircraft Division in 1962. Today, some 30 years later, we are gathered here to deliver the last Viggen aircraft. This goes to prove the long life cycle of military aircraft projects. Considering also the fact that the Viggen will be in service for at least another twenty years, the project will span some fifty years - that is, more than a man's working life.

"It is necessary to have this time frame in mind when assessing procurement costs for new aircraft - not least in today's debate on the costs of the JAS 39 Gripen project."

The Saab 37 Viggen is used as a strike, training, reconnaissance and interceptor aircraft by the SAF. Its maximum speed is over Mach 2, and maximum altitude is 60,000 feet. It can land on a straight stretch of road in 500 yards and take off in even less distance.

The first Viggen prototype made its maiden flight in 1967.

The log book for the final Viggen was received by Anders Kågström, Technical Director of the Swedish Defence Materiel Administration (FMV), who said, "Ever since the first fighter version of the Viggen was delivered, FMV and the aircraft industry, in close collaboration with the SAF, have modified the Viggen to meet new threats and tactics. This work will continue for the life of the aircraft, as long as technically and economically feasible.

"By modifying computer soft- and hardware, and introducing new weapons such as Sidewinder 9L, the potential of the Viggen fighter has been substantially enhanced since first delivery."

The Swedish Air Force has 8 fighter squadrons, 5.5 attacker/fighter squadrons and 3 reconnaissance squadrons equipped with a total of almost 300 Viggens. The last Viggen, #329, will be based in Uppsala.

**NICHOLAS PELLEGRINO**  
FOREIGN MOTOR REPAIR

SALES **SAAB** SERVICE

282 ENFIELD MAIN RD. ITHACA, NY 14850  
607/272-8259

# SHIFTIN' GEARS

by Jack Ashcraft

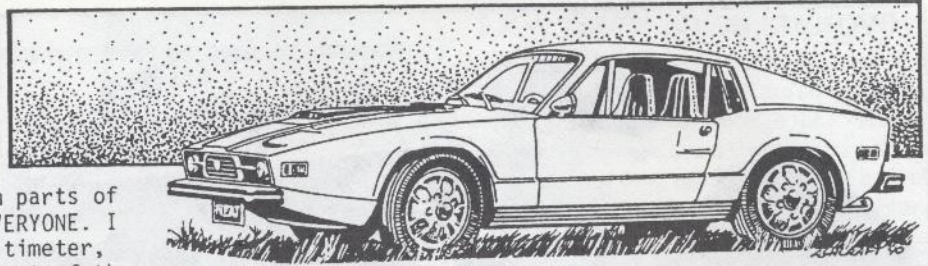

This article is a reprint from parts of my book, SAAB ELECTRICS FOR EVERYONE. I hope you know how to use a multimeter, as space does not allow that part of the book to be included here. Considering the price of new wiper switches, knowing how to attempt a switch repair may be useful to NINES readers. Note that nearly all Saab wiper switches are constructed in a similar manner. Have fun!

## SONETT III WIPER SWITCH REPAIR

If you are really crazy and want to attempt to repair one of these wiper switches, here is how to go about it. Before you start, just realize that you may screw it up or lose an important part or just reach a frustration level where you throw the whole shebang and whatever else is close by into the trashcan. What the hell--it isn't working NOW, so what have you got to lose but some time?

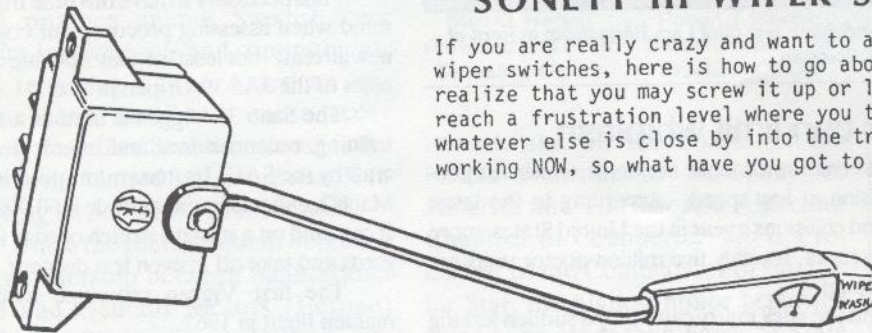

Fig 80

SONETT III WIPER SWITCH

possible to reverse contact A and you don't want to do that. Contact B only fits one way. Both contacts will compress the little springs and fit down into the movable plastic contact mount when you reassemble this turkey. Lift out the plastic contact mount.

Finally, there is another spring with a contact on each end that fits into the inner end of the lever. It must be positioned as shown, before reassembly.

Now what we want to do here is first see if anything is broken, particularly anything plastic. If so, the switch is junk--NO, WAIT--call it spare parts. Put a new one in the car.

Now lets clean up all the contacts in this bear. Start with the base. Clean all the brass contacts after you wipe off the grease with a Kleenex. Using

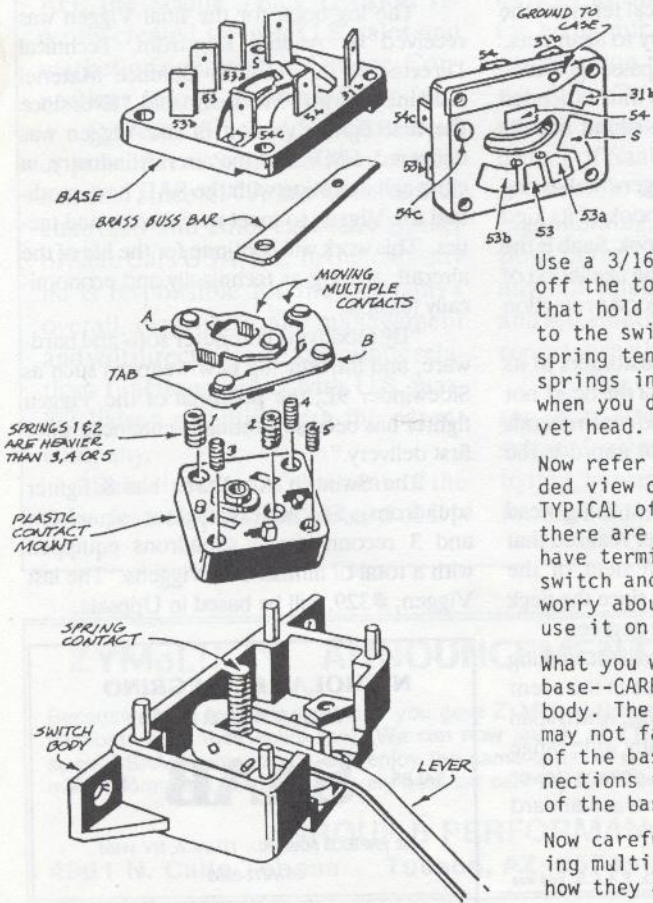

Use a 3/16" drill and GENTLY drill off the tops of the four rivets that hold the base of the switch to the switch body. There is some spring tension from 5 little springs inside so be careful when you drill off the last rivet head.

Now refer to Fig 80, the exploded view of the switch. This is TYPICAL of these switches though there are several variants. Some have terminal S as shown on this switch and some do not. Don't worry about terminal S--you don't use it on a Sonett anyhow.

What you want to do is lift the base--CAREFULLY--up off the switch body. The brass buss bar may or may not fall out. The underside of the base, with the brass connections is shown to the right of the base.

Now carefully lift off the moving multiple contacts. NOTE how they are situated. It is

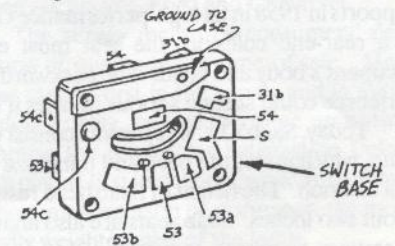

a small piece of 600 grit emory paper, shine up all the contacts, including the spade terminals on the outside. Wipe off the connections and lay the base assembly aside.

Clean the grease off the multiple contacts and shine their contacts

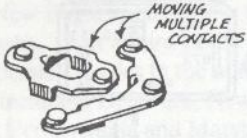

up with the 600 grit emery. If any are severely burned and can not be cleaned up, the switch is spare parts. If the contacts are OK, wipe them off and set them aside.

Pull out the long spring with the contacts on each end that fits into the end of the switch lever assembly. Clean the grease off the contacts and shine them up with the emery. Set the spring contact aside.

Now examine the little springs in the plastic contact mount. Three

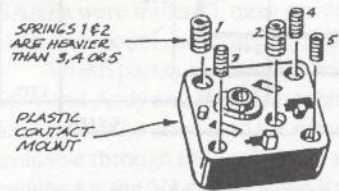

of them should be smaller than the ones under contact A. All should be about the same length and not bent out of shape. Inspect the plastic contact mount one more time for any breaks, cracks or other damage.

If everything checks out, the switch can be reassembled and it should work. FIRST, however, you must lubricate the moving contacts once again. You must use a special electricity conducting grease for this purpose. One such item is offered by G.C. Electronics and is called DIELECTRIC SILICONE COMPOUND, part no. 10-8101. It comes in a tube for about six bucks. Put a bit of this dielectric compound on each of the contacts on the inside of the base, on each contact of the multiple moving contacts, and on each end of the spring contact.

Reassembly is pretty much the reverse of disassembly except you shouldn't have to crawl under your workbench and hunt for that spring you dropped the first time.

Put the spring contact back in place on the end of the switch lever. Set the plastic contact mount back over the spring and lever. NOTE--this thing can go in backwards--don't put it in the wrong way!

Now make sure all 5 springs are in their correct holes in the plastic mount. Set the two multiple contacts in place

over the springs. Their tabs should fit down into the slots provided for them in the plastic mount.

Check that the brass buss bar is in place on the base. You should have put some of the dielectric grease on each contact on the underside of the base (the inside) as well as on the buss bar. Gently set the base down on the assembly with the buss bar side toward the lever. Carefully squeeze the assembly together with your fingers. You may have to wiggle it around just a bit to convince the tabs on the multiple contacts to go into their respective slots in the plastic mount. When it all goes together, tie it in place with two tie wraps (Fig 81). This is only temporary because a permanent fix must be made to hold the switch together firmly or it will not make proper contact and won't work right.

Fig 82 shows one method that works well to hold the switch together. You must take care not to make the attaching plate tabs too long--you must not let them touch any of the electrical contacts.

Fig 83 shows the rough shape of the metal (I used 1/16" aluminum) of the attaching plate. Note the cut-out for the lever pivot.

Fig 84 shows the attaching plate put in place around the switch. Mark your mount hole tabs and drill them for mounting holes. This will keep the attaching plate firmly in place, eliminating any possibility of it shifting and shorting out the wiring.

Put the attaching plate on the switch. Gently bend over the tabs. Make sure that the fit between the base and the switch body is tight. Make sure that the buss bar did not shift out of place or fall out.

Now test the switch as outlined on the next page. If it all works, it is ready to install in the car. CONGRATULATIONS!

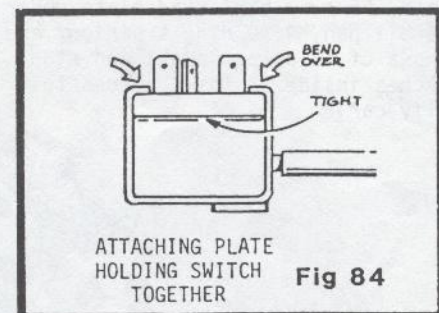
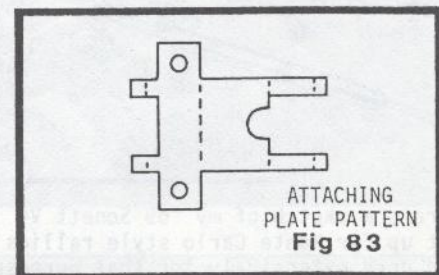
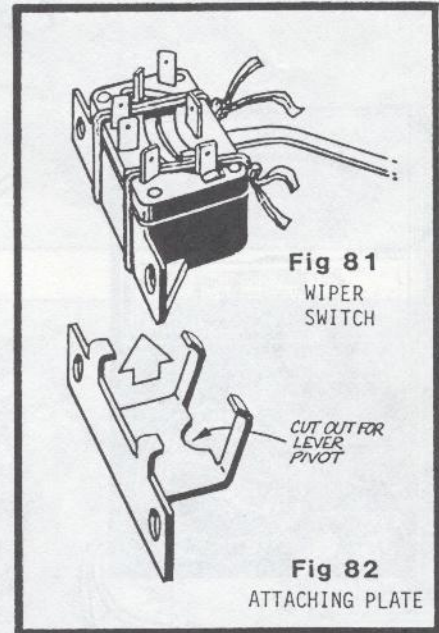

Here is the re-drawn, simplified portion of the Sonett III wiring schematic that shows the wiper/washer circuits. A full explanation of the circuit and how to trouble-shoot it is given in the book. The internal wiper switch connections are shown in this diagram.

SONETT III WIPER/WASHER CIRCUIT

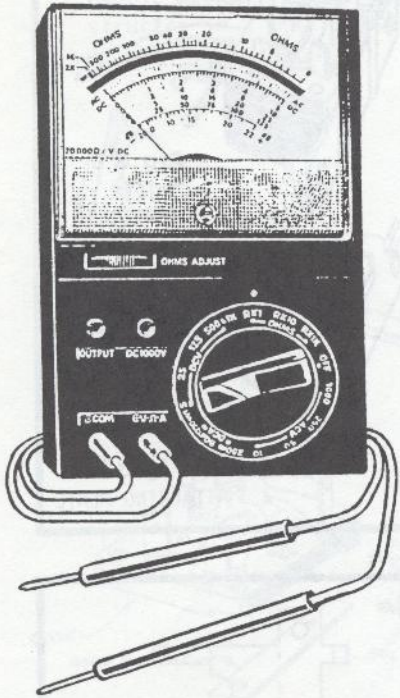
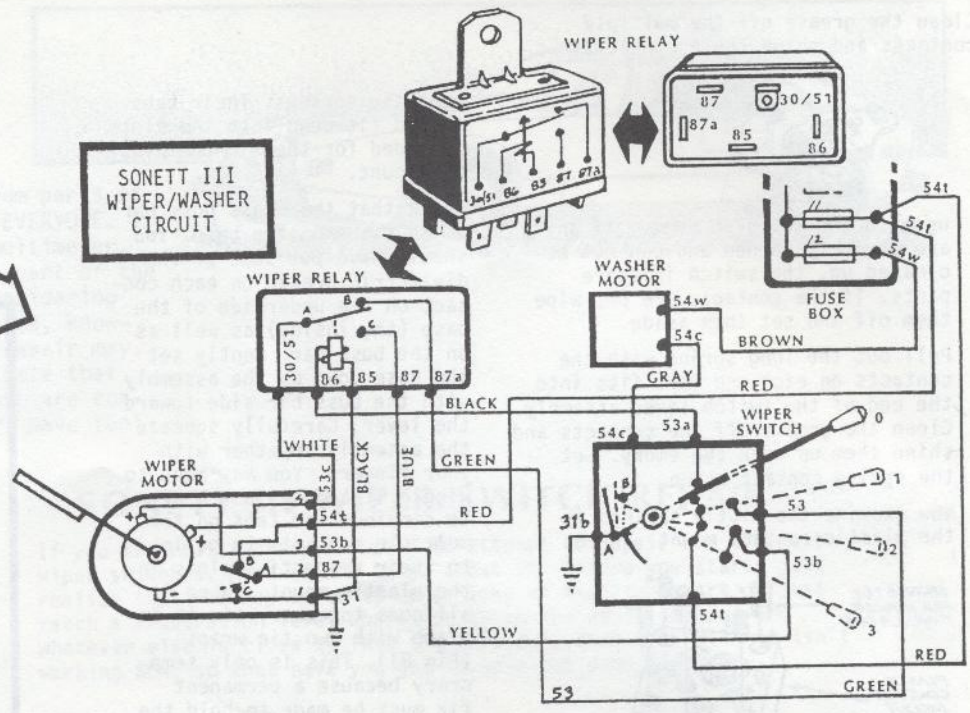

THE MULTIMETER

With the multimeter on Ohms (Rx1) scale and the switch in the OFF position, connect the probes to terminals 54t and 53a of the switch. You should read a short (full scale deflection of the meter needle to the right).

Turn the switch to position 1. Connect the probes across 54t and 53. You should read a short.

Turn the switch to position 2. Connect the probes across 54t and 53b. You should read a short.

Turn the switch to position 3. Connect

the probes across 54t and 53b. You should again read a short. Now connect the probes across 54c and 31b and you should read a short (this is the connection for the washer motor operation).

Turn the switch to either position 1 or 2. Connect the probes across 54c and 31b. Pull the switch (as if you were pulling it towards the steering wheel in the car). You should read a short.

If the switch fails any of these tests, replace it.

Here's a sketch of my '69 Sonett V4 set up for Monte Carlo style rallies and used extensively for that purpose from 1969-72. MUCH modified 1500 V4, Konis, 96 sway bar, skid plate under the oil pan, 4.88 ring & pinion, and a host of Halda equipment and stop watches inside. A fast, successful rally car!

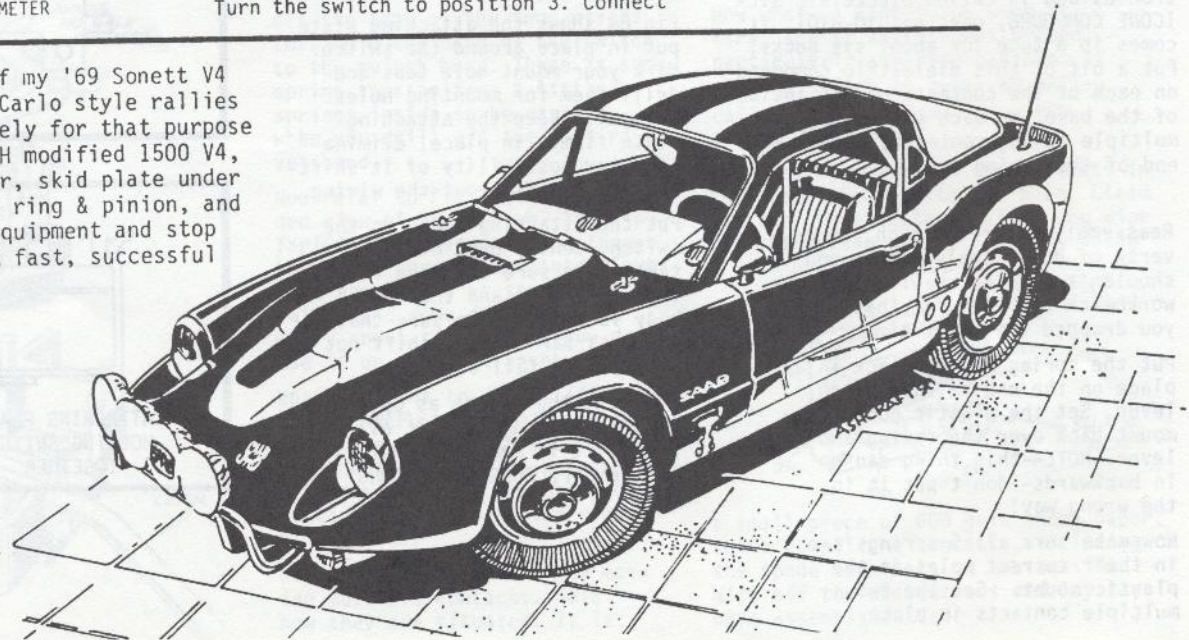

# NC '90

New England has always been a hotbed for Saabs. Over a third of the SAAB Club membership resides in the northeastern U.S., including Delaware, New Jersey, New York, Pennsylvania and Maryland. Consequently, you would expect a bigger than average turnout for a National Convention held in the heart of that area.

Headquarters for Saab's American sales is in nearby Connecticut, so plenty of enthusiasts who work for Saab put in an appearance also.

As usual, the cars were the main attraction. There were plenty of beautifully restored and original older SAABs, as well as a parking lot full of 900s with a few 9000s sprinkled in. Though some of the older SAABs were trailered, most arrived under their own power, be it three cylinder or four.

Worth particular mention was the '72 96-V4 of Andy and Barb Bittenbinder. To look under the hood is to see what was available through the Saab Sport and Rally catalog for the V4 engine when it was a current model. The car is finished in Porsche Guards Red with black accents. Many a mouth watered at the prospect of owning such a car. Andy and Barb spent hundreds of hours in building this 96, and to have such a SAAB built in a restoration shop would run well over five figures. It's no wonder it was judged "Best of Show".

The judge's second favorite SAAB was a 93B that usually sits in the showroom at Clyde Billing Saab in Augusta, Maine. All original, the car was an immaculate trade-in many years ago, with only 18,000 miles on the odometer and the clear protective plastic still covering the inner door panels.

Rare SAABs were also part of the show, with two of the remaining five 1956 Sonett Super Sports on display (see NINES, July 1989), and two of an estimated half dozen 92s in the U.S. Saab Cars USA maintains one of each in their corporate collection, the other pair now belong to Bill Jacobson of Sports Car Service in Wilmington, Delaware. Bill purchased Sonett-I #6 last year, and added a 1955 92B that Richard Lussier of Lewiston, Maine,

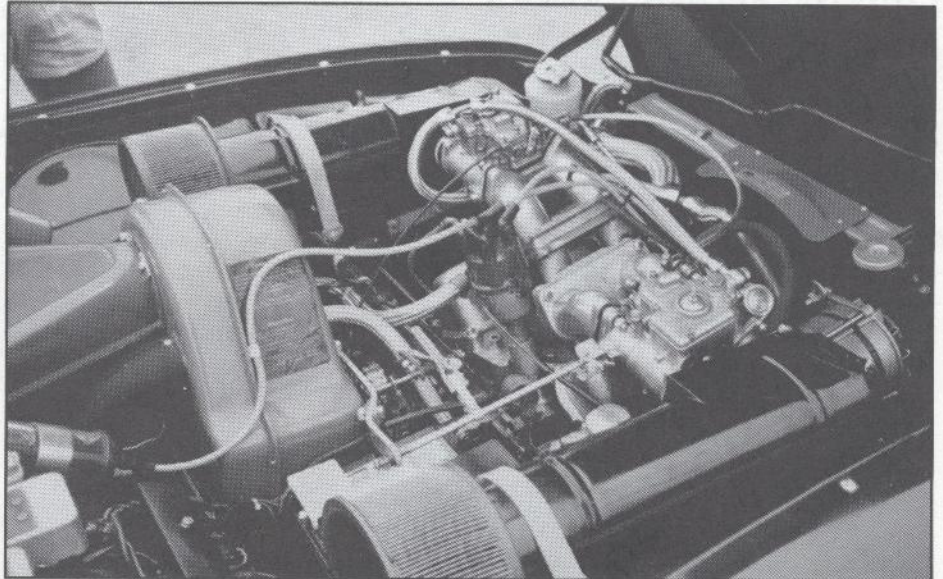

Top: A brace of 99 Turbos.

Center: Under the hood of the Bittenbinders' "Best of Show" 96-V4.

Bottom: Bruce Billing at the wheel of an exquisite 93B.

(Photos by Tim Winker)



brought to this year's convention.

In order to give Saab owners a chance to sample Saab's latest automotive offering without pressure from a salesman, several 2.3 liter 9000S's were available for test drives. The 9000s were in almost constant use on Saturday, with about 170 folks taking advantage of the opportunity.

Special guests included Ralph Millet, who founded Saab's American sales arm in 1956, and that infamous Saab rally driver, Erik Carlsson. Bob and Anne Sinclair and new U.S. Saab president Sten Helling were also on hand to reassure Saab owners about the Saab/General Motors alliance and what it will mean for the future of Saab in this country and worldwide. (See page 23 for some details.)

The '91 Convention will be clear across the country, in Washington state. Vintage Saabs abound in that corner of the world. Expect another tremendous SAAB party!

### Concours Results

#### 92 thru 96

- |     |                 |                   |
|-----|-----------------|-------------------|
| 1st | Bob Abel        | Red 850 GT        |
| 2nd | Wendell Francis | 93F Vintage racer |

#### Sonetts

- |     |              |             |
|-----|--------------|-------------|
| 1st | George Vapaa | V4 Roadster |
| 2nd | Ed Lorenz    | Yellow '74  |

#### 99s

- |     |            |                 |
|-----|------------|-----------------|
| 1st | Unknown    | MA lic #232 BAE |
| 2nd | Doug Majka | Silver '74 EMS  |

#### 900s

- |     |                 |                 |
|-----|-----------------|-----------------|
| 1st | Pete Rechnitzer | Black '83 Turbo |
| 2nd | Pat Bolmeyer    | Red '86 900 4dr |

#### 9000s

- |     |              |                  |
|-----|--------------|------------------|
| 1st | Bud Clark    | Bronze '87 Turbo |
| 2nd | Phil Niemann | '87 9000T        |

#### Best of Show

- |     |                   |               |
|-----|-------------------|---------------|
| 1st | Andy Bittenbinder | Red '72 96-V4 |
| 2nd | Bruce Billing     | Red 93B       |

### Rally Results

- |     |                              |
|-----|------------------------------|
| 1st | Paul Mahoney/Sally Day       |
| 2nd | Jim & Deb Halko              |
| 3rd | Leroy Weaver/Dean Dirian     |
| 4th | Alen & Kay Meade             |
| 5th | Roy Stottler/Kirsty McCarthy |

### Other Winners:

*Olympics* - Michael Outcault, Texas

*Parts I.D.* - Tom French, Texas

*Saab Trivia* - Nancy Parr, Pennsylvania



The 1990 National SAAB Owners Convention is all but a memory, and by the overall response, a great success thanks to all the parties who either supported or attended this annual event. We here at West Mountain SAAB Club truly enjoyed putting on the convention and will give our support and advice for future events. All in all, everything went quite smooth, with only a few technical delays making for some minor difficulties. This event really was a success on both sides of the coin.

The folks from SAAB were in full force, with being so close to home a positive factor. Our sponsors were absolutely fantastic in providing sessions, prizes and entertainment. The group that set up tables and sold items gave a nice touch of true SAAB fanfare. The fanatics that brought all those beautiful SAABs made the parking area a joy to walk through any time of the day or night.

This one had most of the individuals one would want at a national and a few more. There were 435 registered SAABers at NC'90 and many more admirers at the Sturbridge Sheraton. We had a record 142 cars lined up for the big NC group photo. The poster that everyone has asked for is all set, and, yes, you can have your choice of it with or without people. It is a 20" by 30" photograph, not poster paper.

Without all the people involved, this event could not be the great time that it was. Big thanks go out to all of you, including: Cliff Bodenweiser, Mike Blair, Steve Zallen, Kevin Tyrell, the infamous Halko Brothers, Bruce Billing, and Don Miller; the Connecticut and New York groups; everyone from Orange and Meriden especially Steve Rossi, Karin Nobile and Marie Warner for making sure everything was a "go" from SAAB; Erik "Pa Tacket" Carlsson for making it every year faithfully; John Moss for his endless support; Chuck and his crew from Zymol; Frank from Group 6; the Big Three -- Pirelli, Bosch and Spectro Oils; Bill Jacobson for bringing the Sonett Super Sport and all those parts; Trevor Thomas from Henry Mearig SAAB and the super convention folders; the crews from Parrformance and S&J; our own Charles River SAAB for the oil filters; DVSC's Pat Bolmeyer for his very useful info; the Pit Crew for help assembling packages; Scott Prentice, Walter Kern, and crew from the New England Sonett Club; Boe "V8" Kalinoski, Rick Comes, Village Photo, Bud Clark, and the countless other SAAB nuts that I forgot to mention.

In closing, those of you who made it know what happened and those who did not certainly missed one of the best. I want to say we truly feel it's great to be a part of this national "family" and reuniting at the annual gathering. I speak for all of us when I say we look forward to seeing all of you next year in Seattle.

Always in a SAAB  
Dave Sullivan, President  
West Mountain SAAB Club

**NC'90 LAST CHANCE ITEMS**

|  |         |
|--|---------|
| Posters 20"x30" (specify people/no people)             | \$30.00 |
| Pictures 8"x12" (available immediately)                | \$10.50 |
| R10 T-Shirts (White ink on Jade)                       | \$11.00 |
| NC '90 T-Shirts  | \$11.00 |
| Specify size: S,M,L,XL                                 |         |
| Specify color Blue ink on Rose or Maroon ink on Blue   |         |
| Sweatshirts  | \$20.00 |
| Specify size: S,M,L,XL                                 |         |
| Specify Color: Yellow ink on Blue or Blue ink on White |         |
| NC'90 Baseball Cap                                     | \$9.00  |
| WMSC Baseball Cap                                      | \$9.00  |

Note: all orders must be postmarked by Sept 28th to make order deadline. All prices included shipping. Make check payable care of WMSC.

Mail to: West Mountain SAAB Club  
c/o Clifford Bodenweiser  
171 Lancaster Road  
Berlin, MA 01503

**BOB YATES**  
IMPORT CAR SPECIALISTS



**TOLL-FREE PARTS LINE**  
**1-800-669-SAAB**

Fax# 215/752-5614  
Discount to SAAB Club members

Rt. 1 & I-95  
Langhorne, PA 19047

**SAAB ACCESSORIES**

**EURO STYLE HEADLIGHT COVERS**  
protect lights and give your SAAB  
a clean, finished look.  
Specify 900 or 9000 \$49.50

**K Y B Gas Shocks - set of 4**  
99 (specify year) \$92.00  
900 \$92.00

FREE CATALOG AVAILABLE  
**(404) 587-1356**

**VISA** 8351 Roswell Rd, Suite 140 **M/C**  
Atlanta, GA 30350  
**ROADSPORT**

Opposite top: Bob and Anne Sinclair and Erik Carlsson show off their new "Herr Bra-Skiftnyckel" hats.

Opposite center: Zymol was on hand to demonstrate their car protection products

Opposite bottom: Sports Car Service and Reinertsen Motors brought plenty of new and used SAAB parts to sell.

Right: Ralph Millet, who founded Saab's U.S. sales organization in 1956, spoke at the Saturday banquet.

Below: SAABs and SAABers galore!

(photos by Alan Fein)

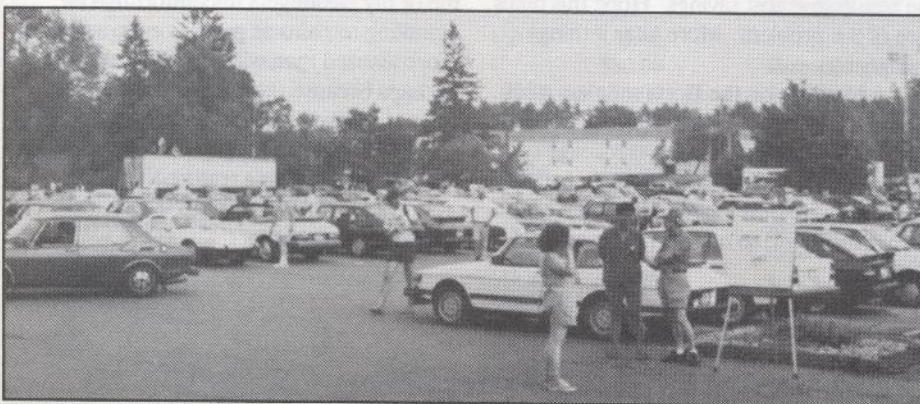
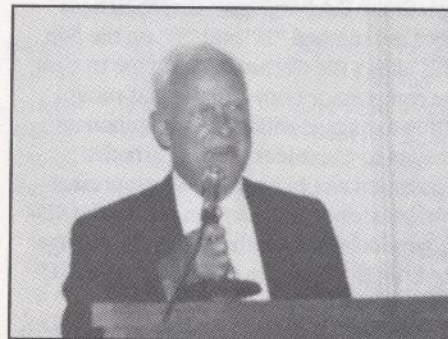

# TECHNICAL TALK

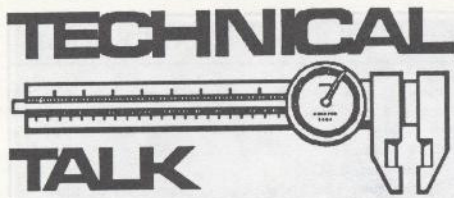

Technical articles written by subscribers may recommend procedures or parts not approved by Saab-Scania of America, Inc. The SAAB Club and NINES cannot stand behind the correctness of information in these articles, but offers them based solely on the experiences of the writers.

## Alternate A/C compressor

The A/C compressor on my wife's '86 900S had been prone to leak at the clutch shaft seal since soon after we bought the car new. The seal was replaced under warranty in 9/88, but the clutch continued to throw oil around the underside of the hood and down the engine and firewall. The original compressor was replaced a month later with the same type, a Seiko-Seiki model SS170PSS, Saab part number 94-81-979. The dealer's diagnosis was that the shaft was bent and had worn out the seals.

Similar symptoms returned this year, and I called Saab Customer Relations in Orange, Connecticut (800-255-9007), to see if they had a history of such problems and could assist with a more permanent solution. They reported no history of chronic seal leakage, but did offer 50-percent "goodwill assistance" provided the work was done by a Saab dealer with Saab parts. However, I soon discovered that, even with 50% off, I could do the job myself at lower cost and perhaps keep the problem from recurring.

The leakage got bad enough to discharge most of a full freon charge within a week. I surmised that another compressor replacement was in order, but the only unit that Saab showed for the car is a Seiko, now P/N 40-70-827, at \$617. With labor, freon, and tax, my share of the 50% deal could approach \$400. (A Sanden unit that Saab once carried for the car is now superseded by the above part number.)

I noticed that the Sanden compressors on my '87 9000T and my '83 Mazda truck did not leak, and that the 9000's A/C belt also required a fairly high tension setting (120 lb. on a new belt, 80 on a used one). It may be that the Seiko unit is not able to handle the high belt tension required in Saab installations, and the shaft bends over time and the seal wears. Anyway, with that logic in mind I went searching for a Sanden unit that would fit the 900. The local Saab dealer had no information on the Sanden compressor previously listed for the 900.

My search yielded a Sanden SD-508, model 9563, with pad-mount hose fittings like the Seiko unit but with a double-grooved pulley instead of a single. It cost \$219 plus tax from AIR in Fort Worth (817/831-2298). Since the 508 is a common replacement unit, one could probably find it widely available at a competitive price.

Slight installation mods were required to make the Sanden fit. First, it had to be shimmed aft with a 1/8" and a 1/4" spacer (supplied free by AIR) at each of the four mounting bolts to make the inner pulley groove line up with the other pulleys. This also required changing the mounting bolts from 35mm length to 40mm.

Secondly, the pad mount holes were at a slightly different location in the end of the Sanden unit compared with the Seiko. This required sawing off the extra mounting lobes located at the upper right-hand fore and aft corners of the compressor (as seen from the driver's seat when the compressor is mounted in the car with the suction port up and the discharge port down). Those lobes are marked "B" and "F" on the 508. This allows the discharge hose pipe to clear the compressor body and the pad-mount fitting to engage with no side-component stresses to cause leaks. An alternative installation would be to use a compressor with independent hose fittings (like the SD-510, model 9146, on the 9000) and change the fittings. Adapters are available at A/C supply houses like AIR.

So far (three weeks) we're pleased with the results and cost savings. Hope this takes care of the problem. More later if things change.

A footnote on the Borla stainless steel exhaust in the 9000 (June 1990, pg. 14): No noticeable change in either gas mileage or performance. Sounds nice, though, and no problems have developed. This was a long-term investment, so no short-term gain was expected.

John Betsill  
Weatherford, TX

## Shocked at KYBs

I own a 1985 900 Turbo, and shortly after its purchase I had the factory sway bars installed. The ride firmed up slightly, but not badly. At about 100,000 miles I noticed that the ride became punishingly harsh. It seems that when gas shocks go bad, they lose their gas charge and thus their damping capabilities. Instead of becoming bouncy like shocks did in the old days, they became more firm. The car might also lose some ride height.

At less than half the cost of factory shocks, aftermarket shocks seemed attractive. A few calls around seemed to confirm that KYB shocks were acceptable to use. I even saw a letter in a past SAAB Club newsletter claiming satisfaction with KYB shocks. So, I had KYB shocks installed.

Well, I don't know what other people think a good ride consists of, but if you think a Suzuki Samurai rides well, go ahead and install the KYB shocks. The ride was harsh and bouncy. At night, on a good concrete freeway, I could see the headlight pattern bounding up and down. In addition, the car seemed to ride almost an inch higher.

I returned to the shop and kindly asked to have the KYB shocks removed and replaced with the Saab Bilstein shocks. I selected the ones designed for use with swaybars. What an improvement!

The Saab now handles rough roads with just enough feedback of the road condition to let me know without making me or my passengers uncomfortable. Handling remains as good as ever, and feels more assured than with the KYB shocks, perhaps because the Saab shocks are less bouncy. Although I still feel that the Saab shocks are over-priced, it was worth having the ride and handling restored.

I now know what KYB stands for: "Keep Your Bilsteins"!

Robert Edelman  
Oakland, CA

## A few 9000 fixes

My '86 9000 Turbo started overheating. I took it to two different repair shops and they couldn't find anything wrong. I turned out that the serpentine belt was coming apart on the inside. It looked normal and felt tight when you gave it a quick check.

While changing plugs, I got a piece of metal in the cylinder and it cost me a lot of money. Check around your plugs before removing. The rework on my engine may have helped, because at 130,000 miles, it has lots of get up and go.

I have the metallic paint (clear-coated) and have never waxed my car. People have told me the car looks like new.

Under the Customer Satisfaction program, I was reimbursed for a broken rear view mirror, had a new set of wiper arms installed, and a sprung door was repaired.

Paul Niedringhaus  
Northbrook, IL

The recent rattle complaint on an '89 900 SPG (SAAB Klinik) was the same one that is infuriating me and my wife. Dr. Nio correctly covered the general area. The

front end of the passive belt rail is right up against the windshield pillar and can hit it when the area flexes, causing a hard metallic slap. Put some felt tape or foam around the end and the clips that hold it. On our car we are bothered by a rushing wind noise coming from somewhere that we just can't locate, and the radio moves around in the dash causing all kinds of noise. If the GM relationship does nothing else I hope it can help with noise, rattle and vibration in these cars. The passive belt system looks like engineer Sven was thrown a lot of parts and told to put them on--somehow!

How about a rust alert story every now and then regarding the 900 and 9000? The story would consolidate all the info already printed and identify places these bodies are rusting and offer solutions. Those of us who plan to keep these cars a long time could use the information about what to look for and trouble spots to inspect/clean/repair. Since Andrews has as much experience as anyone, maybe they could do a story about what they have seen.

Andrews Inc., supplied me a good used 5-speed transmission a few years ago and they know these cars inside and out, literally. They are nice people who really can help.

I ordered a Jacobs computer ignition system from Group 6 Performance and can report a trouble-free installation that seems to supply more torque from idle. I cannot recommend the Jacobs plug wires, however, since they did not allow full boost when installed. The OE wires seem the best although I do have a slight amount of ignition noise on weak radio stations. The Group 6 catalog is great and has some things I've never seen before. Frank Freeman seems to really care about his customers.

Please let us know the cost of the new bodyshell that a reader inquired about. It sounds really interesting.

I've put a set of Goodyear GA 195VR15 tires on my '86 900T and the change is incredible. The ride is orders of magnitude better and Saab should be putting these tires on the whole line. They stick like glue in the dry and wet conditions. Those Pirellis Saab supplies must be really cheap in quantity. With Koni shocks and air bladders in the rear springs, the ride is great and with a little air I get more neutral handling.

James W. Schlueter  
Cincinnati, OH



# BAYSIDE

■ PORSCHE/SAAB/LOTUS



### 9000

|                           | Reg. Price | SALE   |
|---------------------------|------------|--------|
| Euro Headlite Kit         | 425.80     | 340.00 |
| Engine Tuning Kit 86-89   | 312.00     | 250.00 |
| Handling Package          | 946.50     | 756.00 |
| Rear Decor Panel 9000T    | 236.00     | 198.00 |
| Rear Decor Panel 9000CD   | 245.00     | 200.00 |
| Hood Protection Strip     | 37.50      | 29.00  |
| Chime Relay               | 52.10      | 41.00  |
| Sunroof Wind Deflector    | 68.00      | 53.00  |
| Cargo Mat 9000 4 dr. 89 — | 96.60      | 75.00  |
| Cargo Mat 9000 5 dr. 86 — | 94.80      | 71.00  |

### 900

|                              |        |        |
|------------------------------|--------|--------|
| Euro Headlite Kit 87 —       | 430.10 | 345.00 |
| Euro Headlite Kit — 86       | 477.60 | 380.00 |
| Cargo Mat 3 dr. 81 —         | 69.20  | 54.00  |
| 900 CV Int. Cover 86 —       | 100.00 | 81.00  |
| Hood Protection Strip        | 35.90  | 28.00  |
| Air Springs 79 —             | 220.00 | 175.00 |
| Spring Assisted Shocks 86 —  | 78.90  | 63.00  |
| Leather Shift Knob           | 40.00  | 35.00  |
| Air Outlet Covers 3 dr. 79 — | 42.00  | 35.00  |
| Whale Tail 900 3 dr.         | 556.00 | 500.00 |

### 99

|                             | Reg. Price | SALE   |
|-----------------------------|------------|--------|
| Grille Assembly             | 94.50      | 75.00  |
| Head Lamp Doors             | 34.70      | 27.00  |
| Front Park Lens 71 - 76     | 37.50      | 29.00  |
| Front Park Lens 77 - 80     | 44.30      | 35.00  |
| Rear Taillight Lens 69 - 76 | 55.50      | 44.00  |
| Rear Taillight Lens 77 - 80 | 71.70      | 57.00  |
| Wagonback Tail Lens         | 71.70      | 57.00  |
| Rear Side Lamp — 76         | 10.45      | 8.50   |
| Rear Spoiler - Wraparound   | 240.00     | 160.00 |
| Rear Spoiler — Straight     | 210.00     | 150.00 |

### 95-96-97

|                            |        |        |
|----------------------------|--------|--------|
| Front Park Lens 69 —       | 30.40  | 24.00  |
| Rear Taillight Lens        | 38.00  | 26.00  |
| 5 Blade Fan                | 45.80  | 35.00  |
| 95-96 Windshield 68 —      | 151.50 | 120.00 |
| 95-96 Front Fender — 68    | 144.50 | 115.00 |
| 95-96 Front Fender 69 —    | 184.50 | 147.00 |
| 2 Stroke Front Muffler     | 63.00  | 50.00  |
| Sonett III Front Header    | 57.40  | 46.00  |
| Sonett III Rear Muffler    | 66.40  | 53.00  |
| Rear Brake Shoes - Girling | 29.95  | 22.00  |

517 E. PIKE ST.  
SEATTLE, WA 98122

(206) 328-2303 1 800-537-9635 FAX (206) 322-4562



VISA MC AMEX



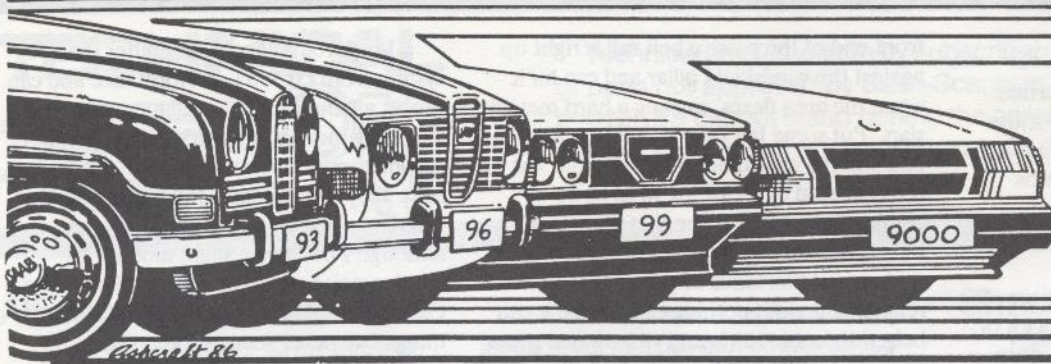

# SAAB SWAP

CLASSIFIED ADS

## CLASSIFIED AD RATES

Ads offering parts or SAABs for sale or wanted are available to members and non-members. Ads are limited to 25 words, plus name address and phone number. Ad copy will be abbreviated and excess words deleted where possible. Enclose sufficient funds with your ad, we do not bill. No ads will be taken by phone. The Classified Ad rate is as follows:

|                                   | Members | Non-members |
|-----------------------------------|---------|-------------|
| CARS FOR SALE                     | \$10.00 | \$15.00     |
| PARTS FOR SALE                    | \$5.00  | \$7.50      |
| WANTED ADS.                       | \$2.00  | \$3.00      |
| COMMERCIAL ADS (Parts & Services) | \$10.00 | \$15.00     |

**DEADLINE:** The 15th of each month for the following month's issue, e.g. January 15th for the February issue. Newsletters are mailed the first week of the cover month.

**COMMERCIAL DISPLAY ADS:** Contact the editor for rates and info. Deadline, the 10th of each month for the following month's issue.

## 93s, 95s & 96s For Sale

'73 96, strong 83k mi, well maintained engine, many new body/mechanical parts, 2 owners, frame rust. Quick sale for \$550. Bill McAveney, Springfield, VA. 703/451-6714 eves or wknds.

'73 96, Lemon Yellow, 170k mi, relatively clean, body fair, Weber carb, radials, good compression, stainless mufflers, recent work, extra parts car. Drive it home! \$400 \$300 obo. Peter Reimuller, PO Box 4, Point Arena, CA 95468. 707/882-2001. \*let's go!

'72 95 Red Wagon, excellent overall condition, very clean, rebuilt engine & tranny 10k, rebuilt brakes F & R, reconditioned fuel tank, new muffler & tailpipe. Michael Childs, Woodacre, CA. 415/488-9557.

'71 95 Red Wagon, 77k mi, no rust on body, more than a little on frame. New exhaust. Used every day. \$1,000. Warren Shoulberg, Bogota, NJ. 201/343-4461.

'70 95, rebuilt 1.7 V4, MSS cam & exhaust, hardened valve seats, big radiator, electric cooling fan, rebuilt trans, F & R KYB gas shocks, Kenwood stereo, exc interior, \$3,800. Jim Smart, Santa Fe, NM. 505/989-8732.

## 2 Stroke & V4 Parts For Sale

Sonett III doors, rear window, etc. (Have just built one S-III from two.) Make offers. Bare body from windshield aft, reasonable fiberglass, rusty pan, Free if you pick up. Jeremy Denny, 20 - 2nd St NE #1204, Minneapolis, MN 55413. 612/379-2658.

95/96 sunvisors, \$25 pr. Alternator, \$20. Voltage Reg, \$10. Front shocks, \$23 pr. Bumper components, headlight bezels, many other items. Monty Tarr, Rt 1 Box 385, Catlin, IL 61817. 217/443-7402 days, 427-5203 eves.

'67 96-V4, not running, spare engine & trans parts. Must sell whole. \$795 obo. Ron Ferguson, Box 36, Harrods Creek, KY 40027. 502/228-8178 or 222-9319 before 9pm EDT.\*

## Sonetts For Sale

Arizona Rust-free Sonetts: Blue '74, 70k mi, fair paint & FG, engine great, good interior, needs freewheel lockout, xint valve, \$1,800 or trade for nice 93B or Sonett II or V4. Orange '73, 60k mi, mighty fine condition, all original, special exhaust. Drive it home, \$4,500. George Reiss, 888 E. Clinton St, Phoenix, AZ 85020.

'74 Sonett III, only 57k mi. New Red paint, upholstery, exhaust & brakes. No rust, exc condition. \$3,900. Tom DeRose, 504 Briar Rd, Bellingham, WA 98225. 206/671-4599 eves.

'74 Sonett III, 108k mi, exc condition, recent mechanical work, new paint, no rust, AC, new tires, extra parts available. \$3,500 obo. Alan Pankau, 415 S. Wisconsin, Mineral Point, WI 53565. 608/987-2126.\*

'73 Sonett III, 72k mi, Blue, engine in top condition, new clutch, needs brake M/C. Some spare parts. Over \$4000 invested, make offer. Greg Downs, PO Box 1122, Cullman, AL 35056. 205/739-6424 after 5pm.\*

'73 Sonett III, 65k mi, new paint, new rocker panels, no rust, runs great. \$3,500. Sports Car Haven, Danville, PA. 717/275-5705.\*

'73 Sonett III, 67k mi, great condition, stored winters, no rust. \$3,500 obo. Jack Carlson, WI. 414/475-0532 or 414/475-1514.\*

'73 Sonett III, Purple, 30k mi, very good cond, factory AC, spare engine & trans. \$3,500. Juan Navarro, Houma, LA. 504/447-7285 W.

'73 Sonett for parts or restoration. Complete, partly restored. Engine/trans by Ericson Ind., non-stock. Stock mags, F & R sway bars, NO RUST! Chassis & suspension Imron painted. Spare eng/trans. \$3,000/all or will part out. Dave Johnson, 137 Ponus Ave, Norwalk, CT. 203/847-1792 H or 834-6176 W.

'73 Sonett III, left front damage, florr pan rusted, \$500. Chuck, Muskegon, MI. 616/739-5332 days, 733-7527 eves.\*

'72 Sonett III, 94k mi, new Candyapple Red paint, good drivetrain, pan & interior. Sunroof, manuals. \$3,400. Jim Grayson, PO Box 491, Pewaukee, WI 53072. 414/691-9137.

'71 Sonett III, Blue, MSS exhaust, alloys, needs freewheel work and master cylinder seals. Includes '73 parts car. Moving, must sell, best offer. Tim Skwiot, 16690 Millar Rd, Fraser, MI 48026. 313/228-0166 lv msg.

'68 Sonett V4 #001111, stripped, fiberglass in perfect condition, pan is rust free, never hit. \$500, or sell me your rusted or damaged parts car. Mark Rheude, 781 E. Swanee Ln, Covina, CA 91723. 818/967-2459.

**99s & 900s For Sale**

'86 900 Turbo Convertible. Limited Edition, 16-Valve, 160 mph, loaded, orig owner. \$20,000 or offer. Must sell. Judy Jackson, Mobile, AL. 205/433-2733 8am-5pm.

'79 99 GL, rebuilt, all records. Must sell due to medical problem. Great for SAAB lover, not many left! \$2,000 obo.

Rob Stites, 19515 Frederick Rd #122, Germantown, MD 20874. 301/428-1082.

'78 99 Turbo, Maroon, 89k mi, seen at '90 Nat'l Convention. \$8k spent on complete vehicle overhaul (mech, chassis, paint, interior) in last 5000 mi. \$4950. Call for photos! Gary Stottler, 1070 W. Dawson Rd, Milford, MI 48381. 313/684-2381.

'78 99 Turbo, 97k mi, Silver gray, Burgundy interior, alloys, sunroof, good running condition, \$1,400. Ed Morrell, Randolph, NJ. 201/361-6439.

'78 99EMS, Silver, well maintained, service records, 153k mi, needs clutch, rings. \$950. Jim Keese, 3966 Orchard Hts NW, Salem, OR 97304. 503/399-7141.

**99, 900 & 9000****Parts & Accessories**

Whale tail spoiler, \$40. 85-mph speedo, \$40. Boost/temp/gas gauge, 82-T, \$40. Elec Ign module, 79-81 900, \$45. Weber throttle body, new, \$75. John Jobeck, PO Box 1028, Lansdale, PA 19446. 855-9179.

One TRX 180/65HR390 tire, 7/32" tread left. \$40 incl shpg. Richard Bohn, 34 Alsun, Hollis, NH 03049. 603/465-2108.

BOBOB child's car seat, new. Made in Holland, formerly sold by Saab. Black with removable grey upholstery, fits 9 mos-4 yrs. \$120. Jim Smart, Santa Fe, NM. 505/989-8732.

5-speed trannys from \$450. Inca wheels, \$300/set. '88-up alloys, \$500/set. TRX wheels, \$25 ea. '86-style steel wheels, \$30 ea. Rebuilt auto trans for Turbo, \$450. Many other 900 parts. Mike Kornely, Blanford Rd, Granville, MA 01034. 413/357-6471.

Set of 4 Yokohama 008R 195/60-15s, approx 3/4 tread remaining, \$120. Autopower bolt-in roll cage, fits 99s & early 900s, \$200. Brad Ross, 7262 Barrett Rd, West Chester, OH 45069. 513/779-4208.\*

Set of four '88 15-spoke wheels, great shape, will ship UPS, \$95 ea. 602/934-0893 lv msg.

Saab intercooler & associated hardware for 82-84 900T, \$345 obo +shpg. Bill Grace, 16335 La Chiquita, Los Gatos, CA 95035. 714/458-9149.

99/900 OEM parts, wholesale prices to SAAB Club members. Aftermarket parts, engines, transmissions, large assortment of used parts. New cylinder heads 81-, new style heater control valve, new style outer CV joints. Call for prices. Installation and service available. Mastercard & Visa accepted. Trollhattan Motors Inc., 310 George Ave, Baltimore, MD 21221. 301/682-4688 or 1-800-32-TROLL. Evening & Saturday hours.

99/900 Headliner kit, comes with glue, 3 1/2 yds of material and complete instructions, \$87.50. Other parts available. Trollhattan Motors Inc., 310 George Ave, Baltimore, MD 21221. 301/682-4688 or 1-800-32-TROLL. Evening & Saturday hours.

Your Saab transmission rebuilt from \$795. Includes replacement of bearings and seals and set to factory specs. Why buy used and not be sure? Freight additional. Mastercard and Visa accepted. Trollhattan Motors Inc., 310 George Ave, Baltimore, MD 21221. 301/682-4688 or 1-800-32-TROLL. Evening & Saturday hours.

Set of 4 '89 900 standard steel wheels & full wheel covers, excellent condition. \$250 for all. 919/766-7619 or 748-2181.

73 99 factory headrest inserts, \$18 + postage (after Oct. 1, free +postage). Mark Headington, 258 Kevin Ct, Onalaska, WI 54650. 608/781-3106.

Parting out: ten 99s and sixteen 900s, 1973 thru 1986. New OE sunroof deflectors, 9000 only, \$40. Rod Beckner, 604 E First St, Albany, OR 97321. Tele/fax 503/928-6351.

Parting out 99 Turbo: Inca wheels, \$75 ea, Turbo steering wheel, \$35. Tach, \$35. Oil cooler w/hoses, \$40. Rear spoiler, \$50. Front spoiler, \$125. Turbo gauge, \$20. EMS wheels, \$80/set. Grille, \$25. Very good interior parts. Michael D'Aleo, 15 4th St. Apt 3, Frenchtown, NJ 08825. 201/996-7603.

Parting out: '79 thru '86 900s. 8-valve, 16-valve, Turbos, SPGs. Drivetrains, interiors, body, suspension, wheels, rebuilt transmissions and more. Mike Caro, Wallingford, CT. 203/284-8989.

9000 15-spoke alloy (p/n 8858910) \$150. 900/99 B-engine head w/valves & cam, \$100. 99 EMS 3-spoke steering wheel, \$35. Jeff Steltz, 4309 Sunrise Rd, Eagan, MN 55122. 612/452-8265.

**Wanted, All Models**

Airbag, ABS master cyl, reservoir, EZK ignition computer for '90 base 900. Rod Beckner, 604 E First St, Albany, OR 97321. Tele/fax 503/928-6351.

Front "chin" spoiler and rear trunk spoiler for 99 sedan. Also any original SAAB accessory items e.g. locking gas cap. Jerry Powell, 7720 Willard Ave, Lincoln, NE 68507. 402/467-5050.\*

Left & right outside mirrors for '71 Sonett. Original chromed bullet-style, new or excellent used. David Ruff, 655 Beacon St #4, Oakland, CA 94610. 415/444-2528.

Maroon corduroy front seat covers to fit a '78 99T. Also looking for a wooden shift knob for same. Ron Raymond, 315/495-6198.

Water pump or main WP seal for '58 93B (pump located behind generator). Also fenders or a complete 93. Anton Ingoglin, PO Box 2956, Setauket, NY 11733. 516/473-5144 9-11am Sat-Tues.

GT 850 engine wanted. Will pay well for reasonably fresh one. Rob Steinway, 540 Iris Av, Boulder, CO 80304. 303/442-4725.

Info wanted on SCCA Improved Touring 99s. Tim Winker, 2416 London Rd #900, Duluth, MN 55812. 218/724-1336.

**412-238-0900, Parts line  
412-238-0099, Fax line**

**DENNIS SWEENEY**  
ROAD TESTED SAAB PARTS  
RD 1, Box 410,  
Ligonier, PA 15658

Buying SAAB parts cars and late-model rebuilders every month.

- Computerized inventory -  
Same day shipping on most items.

Used mechanical and electrical parts, interiors, accessories, sheet metal, rebuilt steering racks, wheels, heads, transmissions.

## Wilson takes '90 Barber Saab Pro Series title

With two races to go in this year's Barber Saab Pro Series, Rob Wilson wrapped up the 1990 Championship, and the \$100,000 Career Enhancement prize, with a fifth place at Road America in

Wisconsin. Wilson, a New Zealander living in England, won five races on the way to the Barber Saab title.

His driving skills in the evenly-matched Saab-powered formula cars hasn't gone unnoticed; he will be driving for an Australian team in IMSA's Camel GTP series in the last two races this year.



## BOOK REVIEW

### Taking the Magic out of Saab electrical systems

Ashcraft's been at it again. Writing books instead of fixing my car. Jack's latest literary effort is *Saab Electrics for Everyone* and covers 95, 96, Sonett, 99 and 900.

*Chapter One: The Basics*, introduces the novice to basic electrical theory; how to read a schematic; how switches, relays, and other gadgets work; and why you'd be nuts not to buy a simple Radio Shack Multimeter. This chapter also includes the European DIN standard wire designations that allow you to apply this manual to other European autos, trucks, and motorcycles (this was news to me).

In *Chapter Two: Saab Wiring Schematics*, Jack walks you through most of the major electrical systems and supplies good trouble shooting hints all the way. His hints on fuses would have saved me a \$60 alternator rebuild I didn't need!

The book is well indexed, and the schematics are nicely drawn and are easier to read than the schematics in the original Saab manual. They alone are worth the price of the book if you do any electrical work.

There are two ways to win with *Saab Electrics for Everyone*. First, for project cars or current electrical problems it is an immediate time/dollar saver. Second, buy it, put it with the *Sonett Sources* book and your new multimeter, and sleep well at night.

The neatest thing about this book is it can be used by novice or expert, as an introductory text or trouble shooting guide, and is packed full of Ashcraft wit, art, and super helpful hints.

Sigurd Erik Anderson  
Portland, OR



# SAAB

## PARTS SPECIALISTS



100%  
GENUINE  
PARTS

Service, Parts, & Prices  
Designed for the  
Long Run!

# 1-800-225-2528

Capitol Import Autos      Authorized Saab Dealer  
(formerly Jack Safo Tosa Imports)  
9201 W. Brown Deer Rd., Milwaukee, WI 53224

### NEW PRODUCTS!

We just located a new line of leather steering wheels. Made in England, they are available in 3 or 4 spoke designs, with genuine leather rims in Black, Red, Grey, White or Blue. Rim sizes 13, 14 or 15 inch. **Priced at only \$89.95 to \$129.95, INCLUDING THE HUB KIT!**

Our **PURE-WASH** is a concentrate for washing your car. It removes all the dirt and helps to neutralize the affects of industrial pollution fall-out, yet is gentle to paint and won't remove wax. **Made entirely by hand using only natural ingredients**, it has no detergents or harsh chemicals, but is made with a pure Tallow-based soap. PH-balanced, it contains Aloe and extracts of Lemons and Apples, plus surface conditioners. **Gentle enough to bathe an infant with at full strength, just 1 ounce will clean your entire car!** For years Mercedes, BMW, Rolls-Royce and others have recommended using plain water to wash their cars. **PURE-WASH** does a more thorough job of cleaning, and is actually better for paintwork than plain water. Each bottle has a free booklet of tips for maintaining your car's finish.

**CLEAN-X** is a multi-purpose cleaner concentrate with a fresh Orange scent. It removes even the toughest grease, dirt, oil or wax. Can be used full-strength to clean an engine, or diluted up to 40:1 for general cleaning. Even diluted 10:1 it is powerful enough to clean your home oven! Great for cleaning tires, it also removes most tar and bug spots. **Both these products are fully bio-degradable and environmentally safe.** **PURE-WASH** and **CLEAN-X** are normally priced at \$5.95 for 8 oz., \$8.95 for 16 oz.; **INTRODUCTORY PRICED at only \$3.95 and \$4.95.** Buy one of each and get a 2 oz. spray bottle of our Baby-Powder air freshener **FREE!**

### GROUP 6 PERFORMANCE

4961 N. Calle Tobosa      Tucson, AZ 85749      (602) 749-1809

## MEMBERSHIP/SUBSCRIPTION

(Use also for Change of Address)

NAME \_\_\_\_\_

ADDRESS \_\_\_\_\_

CITY/STATE/ZIP \_\_\_\_\_

HOME PHONE \_\_\_\_\_ WORK PHONE \_\_\_\_\_

SAABS CURRENTLY OWNED \_\_\_\_\_

(i.e. '84 900 S 4dr. automatic / '78 99 GLE 5dr. 4-spd / '72 Sonett III / '68 96-V4 Deluxe)

\_\_\_\_\_

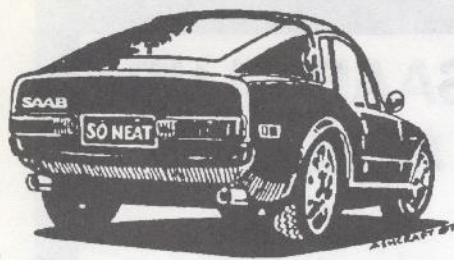

## Rear View

Observations after the convention:

The tie with General Motors (Europe) AG means that Saab Automobile AB is now able to buy such things as Michelin tires at the lowest price, since GM is Michelin's largest customer.

But "Economies of Scale" means more than being able to buy parts at a greater discount. Saab Cars USA now buys its advertising at the GM rate, meaning the advertising dollar goes much farther.

In addition, the U.S. Environmental Protection Agency (EPA) now classifies Saab cars as a GM import -- along with Suzukis and Isuzus sold under the Geo namplate -- for determining Corporate Average Fuel Economy (CAFE). That means that EPA's fuel economy test for Saab 900s and 9000s (or any future Saab cars) is lumped with the Geo Metro and Storm. With the latest "oil crisis", CAFE figures of 35 and 40 mpg are being discussed in congress. Association with GM's Oriental imports is a definite plus for Saab.

Sten Helling disclosed a lower priced 9000 for 1991 - a "stripped" version, but with the 2.3 liter engine - projected to have a suggested list under \$23,000.

Bob Sinclair pointed out to convention-goers an often forgotten fact: The end

consumer is not a customer of Saab Cars USA, Inc. The Saab dealer is their customer, and the Saab owner is the dealer's customer.

Look at it this way: When you purchase an appliance or electronic equipment for your home, you buy from a dealer in a particular company's product. If you buy at a discount store, you don't expect knowledgeable salespeople or good service. But if you buy from an appliance or electronics store where you are likely to pay a little more, you do expect more in service. If something goes wrong, you contact the dealer, who has his technician repair the offending article, at the usual shop rate if the warranty has expired.

The car business isn't all that different. Saab, and virtually all auto manufacturers, make certain requirements of their dealers. These include sending technicians to school on a regular basis, buying *all* the "special tools" needed for repairs, maintaining an inventory of parts, and keeping a "professional" looking facility. Because of this, you can expect the labor rate at a dealership to be higher than at an independent shop.

As an independent business, it is up to the individual dealership as to how they handle service after the sale. Some dealerships are outstanding, while others are downright poor. The majority fall somewhere in the middle, be it Saab or any other marque.

I've seen some interesting engine swaps into SAABS in the past several months. Two were similar - a 16-valve engine into a 99 chassis. The third falls into the "Someone had to try it," category.

Don Andrews of Andrews, Inc. has installed a normally-aspirated 16-valve in a '78 99EMS 3-door. He retained the 4-speed transmission for ease of installation.

Annual Membership fees for the SAAB Club of North America/NINES are as follows:

First Year \$23.00  
 Renewal \$20.00

Canadian add \$3.00U.S.  
 International add \$7.00U.S.  
Please check appropriate box(es)

(Canadian and International -- Money order or check payable on a U.S. bank only. Cash OK.)

First year members receive two recent back issues of NINES and two SAAB Club stickers.

MAKE CHECKS PAYABLE TO "THE SAAB CLUB"

Address change only

For the SCCA Pro Rally circuit, Lee Smith of Swedish Underground in Williamsport, Pennsylvania, has squeezed a turbocharged 16-valve into a '79 99GL 2-door. Lee reports the car is fast, but had overheating problems on the recent Ojibwe Rally in Northern Minnesota.

The B202 engine does not just drop in to a 99. It is necessary to move the firewall and heater box back about an inch for clearance. Engine and transmission mount modifications are also required. Don Andrews says he'll put his experiences on paper to share with the rest of us.

Finally, we have Boe Kalinoski, who runs a shop in Billerica, Massachusetts, called Automotion. His '83 900 is equipped with a V8! The engine is the aluminum block powerplant out of a Triumph Stag, bored out to 3.5 liters, and turbocharged. It took a year to build, and it has over 10,000 miles in its hybrid form.

Note that all of these swaps were done by mechanics, guys who work on SAABS all day long. They also buy SAABS for parts, usually dirt cheap, and have the ability to make one good car out of two (or more) tired cars, since they are intimate with this specific marque. A swap like this wouldn't be practical for a non-mechanic.

The article on transmission lubricants in the July/August issue written by Lyle Kloke was in response to a query by the SAAB Club National Capital Area. *Smoke Signals* editor, Ed Tonat, took me to task for omitting the credit. Consider me guilty of neglecting to do what I ask others to do; give credit to the source of an article.

Tim Winker, Editor

# NINES

The SAAB Club Newsletter  
2416 London Road, Unit 900  
Duluth, MN 55812-2221

Forwarding and  
Address Correction Requested

## September 1990

FIRST CLASS

U.S. POSTAGE

PAID

PERMIT NO. 1909  
DULUTH, MINN.

Exp: 90 12 RZ

FIRST CLASS MAIL

# ANDREWS

INC. OF PRINCETON  
EXCLUSIVELY SAAB

### September SAAB Specials Exhaust Components

|   |                     |
|---|---------------------|
| *T* muffler, 75-89 non-turbo<br>& base 99/900 | \$42.00             |
| *T* muffler, 78-83 99/900 Turbo               | \$49.00             |
| Turbo muffler, 84-on 900                      | \$70.00             |
| Front muffler, 900 16v, non-turbo             | \$67.00             |
| Muffler hangers, 3-hole rubber                | \$2.25              |
| Tailpipe, 75-80 3/5dr, non-turbo              | \$15.00             |
| Tailpipe, 75-80 sedan, non-turbo              | \$12.00             |
| Tailpipe, 84-on 900 Turbo                     | \$42.00             |
| Haynes Repair Manual, 99 or 900               | \$13.50             |
| Trailer hitches, 99/900/9000                  | \$85.00 to \$165.00 |

VISA/MASTERCARD ACCEPTED

Check us out on Used Parts, too.  
All prices plus shipping

TOLL FREE

## 1-800-882-7220

(Fax#: 612-389-3875)

Route 4, Box 247

Princeton, MN 55371



## SAAB CLUB SPECIALS of the MONTH

|                                   |          |
|-----------------------------------|----------|
| Saab/Clarion Compact Disc Player* | \$665.00 |
| 9000 Thule Roof Rack              | \$90.00  |
| 900 Thule Roof Rack               | \$53.00  |
| Leather Shift Boot 900            | \$65.00  |
| 9000                              | \$85.00  |
| Rear Spoiler, 9000 Sedan          | \$330.00 |
| Hood Edge Strip, 900 & 9000       | \$30.00  |
| Engine Tuning Kit* (HP Boost kit) | \$250.00 |
| Oil Drain Can                     | \$9.00   |

\* Additional parts or info may be required for your installation

### WE KNOW SAAB'S

Prices subject to change  
without notice.  
Expires Month End.

## 1-800-225-2528 FAX 414-355-7831



AE

Open 8 am to 6 pm  
Monday thru Friday