



NINES

THE SAAB CLUB NEWSLETTER

\$1.50

July
1987

no. 161



HIGH PERFORMANCE SAABS -- Sweden's newest high-performance aircraft, the JAS-39 Gripen (Griffin), built by Saab-Scania AB, was recently rolled out for its first public appearance. Shown here with another high-performance vehicle by Saab-Scania, the Saab 9000 Turbo, the Gripen is a multi-role aircraft able to perform fighter, surface attack and reconnaissance missions and offers the latest in aerospace technology. The Gripen is expected to make its first flight this fall and to enter service with the Swedish Air Force in 1992.

CONVENTION THIS MONTH

News of the 1987 Saab Owners Convention in Tulsa, Oklahoma, has been published in NINES for many months, and the big weekend is finally upon us. Chairman Jim Glavas of the Tulsa Saab Club reports that plans have gone smoothly, and that everything is pretty much ready for July 24th thru 26th at the Hilton Inn of Tulsa. Jim also reminds those who plan to attend that all Convention functions will be semi-formal at best, with blue jeans the normal attire. "This is Oklahoma, one of the gateways to the West," says Glavas. "Cowboys and truck drivers are what have made this area famous."

On the schedule for the Convention weekend are Tech Sessions, a Swap Meet, a Concours/Car Show (in which all cars will be eligible for some prize), and a "Gumball Rally" limited to 30 cars. Baby sitting service is offered during the Friday Get Acquainted party and Saturday's Banquet. Some free time for sightseeing in the Tulsa area has also been scheduled.

The Convention fees are \$50 per

person and include the cost of the parties and continental breakfast. Send the convention fees, plus \$10 per car for the Gumball Rally, to:

Jim Glavas
2705 So. 74th E. Ave.
Tulsa, OK 74129
(918) 663-8087

Rooms at the Hilton Inn are \$39.50 for one to four persons. Reservations at the host hotel may be made by calling 918-622-7000. The Hilton Inn is located at I-44 and Yale in Tulsa.

TROLLHATTAN PROGRAM ANNOUNCED

Music, an Air Show, and of course Saab cars will be the highlights of the special weekend organized by the Swedish Saab Register (Svenska Saab Registret). The event is the Golden Jubilee of the foundation of Svenska Aeroplan AB in 1937. Saturday, August 29th will be International Saab Clubs Day, set aside for Saab club members from around the world to meet and visit. The following day, Sunday, August 30th, will feature live entertainment, an air show, and tours of the Saab factory.

SAAB DATA REFUTES GOVT TEST

Saab-Scania engineers recently crashed five new Saab 9000s. The cars were destroyed in testing done under the same conditions as the National Highway Traffic Safety Administration (NHTSA), straight into a solid barrier at 35mph. The results seem to back up Saab's claim as manufacturer of some of the safest cars on the road.

Robert J. Sinclair, president of Saab-Scania of America, wrote in a letter to Saab Club member Alan Clarke of Newhall, California:

"The test, conducted in March of 1986, consisted of a single 35 mph head-on impact into a rigid immovable barrier. The results for the Saab 9000 were declared invalid by Saab-Scania because post-test inspection of the test vehicle revealed that, apparently due to human error, the driver's seat was not securely latched on the inboard side when it was repositioned prior to the test. As a result, the seat moved unexpectedly during the impact and caused abnormal test dummy

CRASH TESTS

continued on pg. 8

Cars from the Saab Museum will be on display and in a parade. There is a possible Auto Thrill Show including ramp-to-ramp jumps (yumps?), and two-wheel driving, all done with Saabs. Also on the agenda is a "test circuitrace with Saab 9000 turbo".

Several Swedish musical groups will provide entertainment in a couple of programs. A one and a half hour air show featuring Saab military and civilian aircraft will be another of the highlights, with formation flying demonstrations by Saab jet fighters, and aerobatics by several different planes.

For those who are planning to make the trip to Sweden for the 50th Anniversary via the New York SAS group flight, Paul Florance reminds you that all the money for the trip must be in to the Seal Beach Travel agency by August 1st. Paul also reports the Club Sonett Sweden is planning a farewell dinner in Stockholm for those in the U.S. group on Friday, September 11. Further details will be published in the next issue of NINES.

FROM THE BACKSIDE

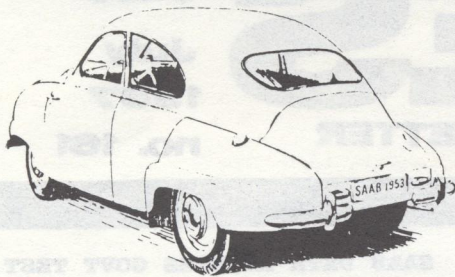

A couple of months ago I mentioned that club members occasionally send in articles clipped or copied from magazines, some of which I utilize in writing for NINES. Many folks also send in photos of their personal Saab transport. Some are fixed up a little, some a lot, some are stock but nice looking. Those photos don't get published as they don't fit in with the "technical" nature of NINES. They don't get thrown away either. They are being saved in a photo album, to be shown at Saab functions wherever I may be. If you have a favorite Saab photo that you'd like to see included in the club archives, send it in along with any particulars (modifications, miles, etc.).

Speaking of magazines, in the July issue of *Automobile* David E. Davis, Jr. says of the 9000 Turbo, "I only wish that the 9000 looked more like a Saab and less like all those Renaults and Lancias. It has lost its charming quirks and become a generic Eurosedan. But, thank goodness, the part between the ball of your right foot and the pavement is still 100 percent Saab Turbo."

Saab advertising brochures and other paraphernalia are also being saved for the club library. If you have old Saab posters or flyers that you hate to toss out, but don't really need around the house anymore, send them to the Club. I'll see to it they get preserved for future generations of Saab fanatics.

Several other articles were ready for inclusion in this month's issue, but I ran out of space (and time to put it all together). In response to those who want to get better performance out of their 99s and 900s, Swedish Express, Inc. and yours truly have put together a series of articles on what has been done to my '79 99GL. All modifications are bolt-on, and each can be installed in a matter of

hours. We're not out to find neck-snapping horsepower, just a few improvements over box-stock. Look for the first installment in the next issue.

There will also be a NEW PRODUCTS column next month, as we have received releases of several new goodies for Saabs. If you have tried any new products designed specifically for Saab, write it up and send it in.

Speaking of the next issue, it will be the combined Aug/Sept issue. Look for it in late August.

There have been several new advertisers over the past few months. Make sure you mention that you saw the ad in NINES. One ad that deserves mention was in last month's issue, a Bed & Breakfast Inn in Ontario, Canada. It is run by Janie Geall of the Saab Owners Club of Toronto. Janie has attended the last couple of National Conventions, so you may have met her. Mention NINES and get special room rates.

I have received several calls and letters about Viking Parts and Repair in Princeton, MN. They are not out of business, but have been reacquired by Andrews, Inc. a.k.a. Andrews Auto Body. Chuck Andrews assures me they will remain open as the parts and repair are directly adjacent to his auto body shop. See their ad in this issue for the phone number. If you should ever have opportunity to drive through Princeton (north of the Twin Cities), stop by as they have a very impressive facility. They are also true Saab fans.

Once this issue is in the mail, it's off to Tulsa. Hope to see you there. Wear your cowboy boots & hat.

Tim Winker
Editor

REGIONAL CLUB NEWS

APPALACHIAN SAAB CLUB -- July meeting at Tulsa convention, August meeting at the home of Brenda & Dewey Foulk in Knoxville. For info: Wendell Francis, Rt. 5, Box 334, Dandridge, TN 37725. (615) 397-2172.

CENTRAL ILLIANA SAAB CLUB will not meet until September. Call Margrit Adler, 1507 W. University Ave, Champaign, IL 61821. (217) 356-9244.

DELAWARE VALLEY SAAB CLUB -- No meetings in July or August. Contact Doug Signorovitch, (215) 622-7047

GREAT LAKES SAAB CLUB -- July 11th meeting, Pool party at 1pm at Jim & Mary Laman's. August 5th, tentative meeting/picnic. Jim Laman, 763 Larkwood Drive, Holland, MI 49423. (616) 335-5215.

NORFOLK, VA area -- contact Alan Bellinoff, (804) 340-7097.

NORTHERN ILLINOIS SAAB CLUB -- 24 hour Events Hotline, (312) 763-4752.

SAAB CLUB NATIONAL CAPITAL AREA will join the Volvo club for a reception at the Swedish Embassy on October 10th. Meetings on the second Thursday of the month at the Bethesda Regional Library, Bethesda, MD. Toby Turpin (301) 384-6732.

SAAB CLUBS OF GEORGIA -- meets 1st Monday of the month at Steak & Ale, I-285 & Roswell Rd, Sandy Springs. Meetings start at 8:00.

SAAB CLUB OF S.W. OHIO -- New club forming. Next meeting July 27th, 7:30pm at Blue Moon Saloon, 123 Boggs Lane, Cincinnati, OH. Contact Jim Schlueter, (513) 681-2800.

SAAB OWNERS CLUB OF TORONTO holds their annual Driving School on August 14th at Shannonville race track. Contact John Casey, (519) 576-4320 days.

SOUTHERN CALIFORNIA SAAB CLUB will have a "Long Run Video Fest" featuring Saab videos, August 2nd, 4pm, at Paul Florance's. Beta & VHS machines available so bring your tapes. The BBQ will be fired up, B.Y.O.Meat. 126-1/2 Main St, Seal Beach, CA 90740. (213) 493-6707.

TULSA SAAB CLUB hosts the 1987 National Saab Owners Convention, July 24th-26th at the Hilton Inn in Tulsa. Jim Glavas, (918) 663-8087.

VINTAGE SAAB CLUB OF WASHINGTON STATE will meet for a Picnic, Swap Meet and Tour on Sunday, July 12th at Swak Campground, Blewett Pass on Highway 97, approx. 20 miles from Ellensburg, WA. Meet at Perkins Restaurant, I-90 in Ellensburg at 11am, or at the campground at Noon. Call Shawn Irelan at (509) 548-7279, Joh Baird at (509) 653-2057 or Rich Roberts at (206) 328-2303.

WEST MOUNTAIN SAAB CLUB (New York/New England) -- Annual meeting July 18-19 at Singletary Gun Club, Oxford, MA. Events include Car Contest, Concours, TSD Rallye, Group photo. Contact David Sullivan, 314 Union Av, Framingham, MA 01701-6319. (617) 879-8288 after 6pm; Tom McDermott, (518) 798-1577 days; or Mike Blair, (617) 525-3872.

Saab Club of North America

Editor & Publisher: Tim Winker, 2416 London Rd., Unit 900, Duluth, MN 55812

(218) 525-3253, 9 a.m. - 8 p.m., except Sunday

ASK BOB

Send your questions to:

ASK BOB
c/o NINES
2416 London Road, Unit 900
Duluth, MN 55812-2221

There have been several replies to recent "ASK BOB" letters, so it was decided to feature them this month.

Regarding L.S.'s questions in the June 87 issue:

1) I thought the "clunk" when backing up was designed by Saab to help knock off brake dust buildup.
2) Not that one is not proud to own a Saab, but who needs 3 "turbo" emblems? Try a nylon fishing line to break the bond between the adhesive and paint. Rub off the residual adhesive with TR-3 polish. Consider the age (fade) of the paint before you start.

Keep up the great answers.

Andrew Ko
Long Beach, CA

On synthetic oil -- Not only is it better in every way to mineral based oils, but it is very important for turbos as the heat build up comes after the engine is turned off and mineral based products can turn to "coke" as they carbonize. It is this carbon buildup that can help to destroy the turbo before its time. Synthetics do not "coke".

Saab does approve the use of synthetic oil. See SAAB SOUNDINGS, Vol 24, No 1, Tech Tips. "Synthetic engine oils are approved for use in your Saab so long as the proper viscosity and API Service Rating is used (SF/CC or SF/CD). Extended oil-change intervals are not approved even though the oil manufacturer may claim factory approval. Engine oil additives are not recommended."

In addition while in Gothenburg picking up my new SPG I noticed that Saab has a synthetic oil in the European parts catalog.

Lastly, the 9000 Turbo comes from the factory with synthetic oil and it no longer requires the 1000 mile oil change.

I have used synthetics in all my cars for the last few years and swear by them. Mobil-1 5W30 is best. I also use AMS/OIL synthetic gear lube in the trans. Try it, you will never go back.

You can remove the "900" and "Turbo" emblems with a hair dryer from the trunk. It should be done on a warm day and you can use a tapered stick of soft wood, cardboard or plastic to help pry them off. Mine came off without a hitch and the car looks better without them. It has nothing to do with being proud of the car.

M. Lerner

"ASK BOB" is a regular feature of NINES. Submit your questions with as complete information on the problem as possible, also giving the year and model of SAAB. Problems that are of general interest will be answered here. Questions regarding High-Performance tuning and modification will not be considered for publication in this column.

Neither Bob, NINES, nor the Saab Club will be responsible for repairs undertaken as a result of information in this column. For a proper diagnosis, it is recommended that you have your car serviced by an authorized Saab dealer.

Regarding the "clunk" in the front brakes when backing up -- My 99 did that for awhile until I replaced the front rotors and pads. I was told that the holes for the pads had elongated. The old rotors were a bit warped (a "pulsing" feel through the brake pedal), so that may have caused the problem with the stretched holes.

L.S. problem might be a wearing outer C.V. joint, or the caliper may be worn on its slide. I have recently had this problem on a '75 99 and an '82 Turbo. In both cases the outer C.V.s have been worn. The '82s caliper also "rattles" in its slide.

"The Renovator"
Pittsville, WI

First, I don't feel it is proper for "ASK BOB" to take artistic license and edit letters. He edited my letter, made an error in a statistic, and the entire meaning of the letter was lost. (The letter dealt with front end alignments in May 87 issue.)

Secondly, a reader stated (again in the May issue) a problem with a temp control vibration on a Saab 900. "BOB" responded with a "recall". My own experiences have found this vibration to be associated with the heater control rod. They sometimes loosen with age, and even crack at the plastic end pieces. A new one costs about \$15 (plus labor). If it is not positioned absolutely correctly, it can buzz or rattle beyond belief!! Make sure it is attached securely at the fascia panel first, then onto the heater valve.

Turning to "Synthetic oil" as mentioned in the June issue, Saab neither endorses it, nor prohibits the use of synthetic oil, as long as it is changed at Saab's prescribed intervals. This obviously is important to all Saabs under warranty.

I have used Mobil-1 5W30 for sometime now here in Michigan in both an '83 8-valve non-turbo and an '86 16-valve non-turbo. Additionally, I use synthetic Mobil-1 75W-90 in my 5-speed gearbox. I have never never had any problems related to synthetic oils (and this comes from driving 40,000 miles each year). But I agree with Saab; change your oil at the prescribed intervals, or enroll in an oil-analysis program as a second choice.

Tad Gilliam
Grand Rapids, MI

There has been much discussion recently about the optimum lubricant for the Saab 5-speed transmission (NINES, March 87; ROAD & TRACK, Technical Correspondence, May and July 1987). From 1975 on, Trollhattan has recommended 10W-30 or 10W-40 petroleum based engine oil. Some Saab enthusiasts, however, believe a synthetic gear lube (75W90) helps insure a long and smooth trans life. The jury is still out, but I've sided with the synthetic proponents and recently decided to get some synthetic gear lube. 75W90 oil, for those who've looked, is hard to find. After some digging, I've located only one source: AMS/OIL Inc., Superior, WI 54880, (715) 392-7101. 75W90 AMS/OIL, a dibasic ester synthetic that carries the highest pressure rating (GL5), is available from independent jobbers; among them Terry Keaton in Houston, TX (713) 664-5241, and Jim Youngkin, 920 E. 2nd St, Nescopeck, PA 18635 (717) 759-1709. A case of 12 quarts (retail, from Terry) came to \$84 including COD charges to Connecticut. The price drops, of course, with larger orders.

Jim Kent
New Canaan, CT

I've used nothing by AMS/OIL in my cars, Saab & other, for almost 10 years now. Have had absolutely no problems. Oil analyses show below normal wear and oil is good far longer.

[This letter included a flyer on AMS/OIL TurboCharge, 100% synthetic SAE 10W-30 motor oil for use where the manufacturer specifies API Service SF-CC-CD.]

Richard A. Johnson
AMS/OIL Direct Jobber
7610 Salem Rd.
Falls Church, VA 22043.

Bob says:

It is sometimes difficult to make diagnosis via a few written paragraphs, and many letters tend to ramble a bit, so I must rely on past experiences of the more common problems. My answers won't always be absolutely correct for your problem, but do give an indication of where you might look. As the saying goes "Everyone's entitled to their opinion".

I'm glad to answer your questions, now how about some of you returning the favor? Has anyone found a way to clean automobile windows so they "sparkle" and are streak free?

SERVICE SUBJECTS FROM SAAB

DOOR TRIM SEAL PULLING AWAY FROM "B" PILLAR

Application: 9000 models
S.I. 05/87-961, B-8/P.16

The problem of the door seal pulling away from the "B" pillar can be rectified by the installation of clips to hold the seal in place. Other means of securing this seal (such as adhesive) are not recommended because of the handling difficulties if the seal needs to be removed later on.

Clip (4 per side) 84-12-215

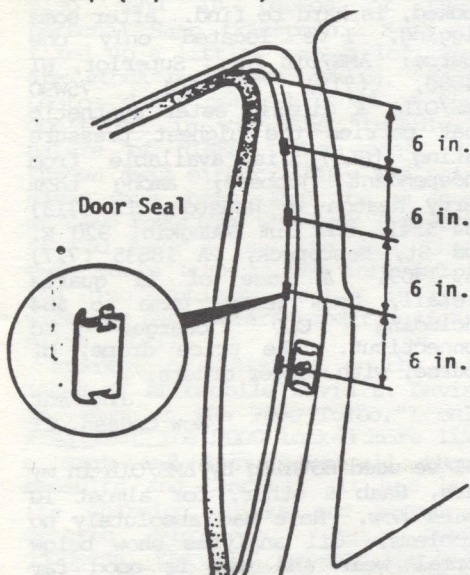

Repair Details

1. Remove the door trim seal from the "B" pillar. Carefully clean all oil film from the metal flange (where the clips will be applied).
2. Apply a strip of fabric tape to the metal flange. This protects the paint from damage by the clips.
3. Fit 4 clips to the metal flange, spaced as shown in the drawing. Refit the door trim seal and press into place.

CRUISE CONTROL MEMORY LOSS AND NO POWER SUPPLY

Application: 1987 900S, 900 Turbo
S.I. 05/87-963, A-3/P.105

During 1987 900 production a new cruise control electronic unit was introduced. During this introduction, two problems arose that may affect the operation of the system. Please see the following for a description and the corrective measures.

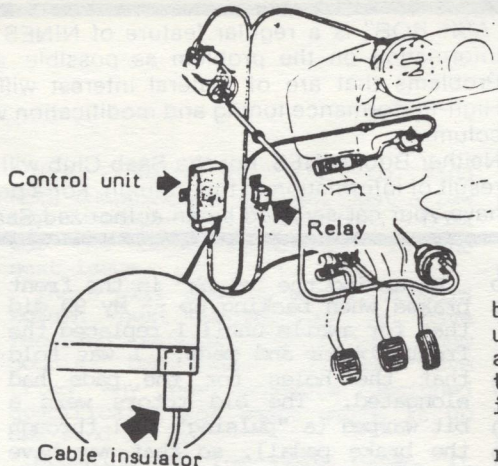

System Relay

Some incorrect relays were installed (see drawing). The correct relay is black plastic and marked 95-63-099. Incorrect relays, P/N 85-91-455, are galvanized metal. Problems with the relay can cause a memory loss. They should be replaced with the correct version.

Power Supply

The plastic wall around pin 9 (12v+) for the new control unit has been changed. On certain cars the black insulator over the wire connector is too large and can cause a loose or intermittent connection. Replace the old insulator with a new one, P/N 85-16-916.

NEW DRIVE SHAFTS

Application: 900 w/Manual Trans
S.I. 05/87-964, A-4/P.101

A new design driveshaft was introduced into M87 900 production from VIN Serial No. H2015555, H3010968, H7020169. The driveshaft is 6mm longer than earlier designs and improves the location of the universal joint in the inner driver. New driveshafts may only be installed in cars with the large inner drivers. It is not necessary to replace the driveshaft in pairs.

Earlier version:

LH 89-90-731
RH 89-90-749

Replaced by:

91-02-823
91-02-831

PROTECTIVE EDGING FOR REAR SEAT UPHOLSTERY

Application: 9000 models with Velour interior

S.I. 05/87-965, B-8/P.18

Protective edgings for the lower outer edges of the rear seat were introduced as a running change. These edgings may also be fitted to an earlier car with the velour upholstery to correct a complaint of wear along the edge of the fabric.

Protective Edging

96-97-459

Cars built after the VIN Serial No. given below already have the protective strips installed.

H1015194-

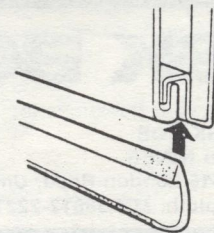

Installation Details:

Fit the edging strip in the gap between the steel frame and the upholstery. Position the strip approximately 13/16" (20mm) in from the rear corner seam. Press firmly into place.

Two protective edgings are required per car. If necessary, the upholstery should be replaced at the same time if badly damaged. The protective edgings will prevent future damage.

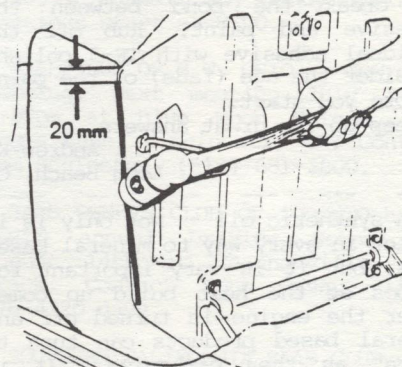

ADVICE FOR INSTALLING FIRE EXTINGUISHER

Application: 1987 900S with Passive Seat Belt System
S.I. 05/87-966, A-9/P.69

Due to the new seat and seat base configuration, the Saab Halon fire extinguisher, P/N 02-02-515, cannot be mounted under the front seat of models with Passive Seat Belts. Saab suggests that accessory fire extinguishers be instead mounted in the trunk.

Installation Instructions:

1. Remove the five plastic retainers securing the carpeting to the left, rear, quarter panel. Fold the carpet down and out of the way.
2. Using the fire extinguisher bracket as a template (see drawing), mark the location of 900 3dr LEFT REAR INNER QUARTER PANEL

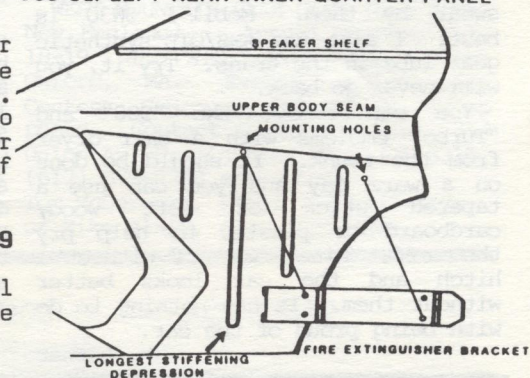

SERVICE SUBJECTS continued

- the two mounting holes. The bracket should be parallel to the speaker shelf and over the longest stiffening depression.
- Drill the two holes shown in the drawing, using a 1/8" drill bit.
 - Fold the carpeting back into place. Install the plastic retainers. Make holes in the carpet to correspond to the holes for the extinguisher bracket.
 - Mount the extinguisher bracket using #8x3/4" sheet metal screws. Clip the extinguisher into place.
- NOTE: Do not attempt to drill through the carpeting as it can catch on the drill bit.

Additional Advice:

The fire extinguisher will interfere and prevent the rear trunk floor from being raised to the fully open position. Given below are instructions and a spare part list for installing a strap to hold the rear trunk floor in a less than fully open position. The strap will permit easy access to the spare tire.

Rubber Strap	97-97-127
Rivet	79-61-675
Knob	97-94-264
Screw	97-75-230
Washer	79-13-833

- Drill a hole in the track for the parcel shelf on the left, rear speaker shelf (see drawing for location), using a 3/16" drill bit.
- Rivet the strap to the bottom side of the sheet metal using the rivet and washer, as shown in the diagram.

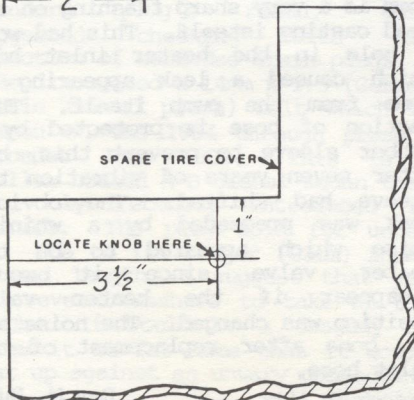
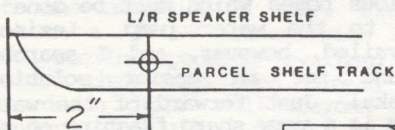
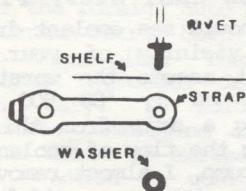

- Mount the knob to the bottom side of the spare tire cover (see drawing for location) using screw 97-75-230.
- Check that the strap will support the rear trunk floor when raised.

MODIFIED KNOCK DETECTOR

Application: 900 and 9000 models with Knock Detectors, EZK Ignition & APC Systems, 1983-on
S.I. 05/87-967, A-3/P.106 (900)
S.I. 05/87-968, B-3/P.8 (9000)

New Type Knock Detector

A new knock detector with improved mechanical properties has been introduced into production from Engine No. G122319. The new knock detector, P/N 75-68-801, replaces the earlier type and can be distinguished by being 3.5mm taller and is secured by a longer (30mm) bolt, P/N 81-25-197. When fitting a new knock detector to earlier cars, the longer bolt must be installed as well.

Tightening torque 14.7 ft.lb.

Early Type Knock Detector

A new bolt has also been introduced for the early type knock detector. The bolt is the same length as before, but is treated with a special blue coating that acts as a thread lock. If the early type detector is disturbed for any reason always install a new bolt.

Bolt (27mm) P/N 75-62-168
Tightening torque 10.3 ft.lb.

Saab Service Tips & Service information are provided to the Saab Club as a courtesy to Saab owners by Daniel L. David, Manager of Technical Services, and Robert J. Sinclair, President of Saab-Scanir of America, Inc.

Exclusive SAAB Parts Center

The area's most extensive inventory at competitive discounts.

(215) 886-8660

Free delivery or UPS



Exclusively SAAB since 1958

1125-35 Easton Road • Abington, PA

Rollster®

NOKIA
TIRE DIVISION

Finland

- Less rolling resistance
- A firm grip in wet driving conditions
- Unique driving characteristics and comfort

Tread. The wide peripheral grooves and lateral grooves opening to the sides restrict the danger of aquaplaning by allowing an easy exit for water from between the tire contact area and the road surface.

Stabilization belt (nylon) in tires 165 SR 15 and larger improves driving characteristics and reduces low speed steering.

Steel breaker strips. A new type of steel cord improves driving comfort and increases the life of the radial tire.

Carcass (rayon). In tires 165 SR 15 and larger there are 2 woven plies of rayon. This new construction increases the strength of the tire, precision of tire shape and length of tire life.

High Apex side wall construction guarantees consistent driving characteristics.

65-70-series
now T-rated

165SR-13	\$58
175SR-14	\$70
185SR-14	\$73
165SR-15	\$69
175/70TR-13	\$66
185/70TR-13	\$72
175/70TR-14	\$74
185/70TR-14	\$79
195/70TR-14	\$82
185/65TR-15	\$92

(each incl. UPS shipping)

For more information and to order, Call: PAT GREER
(414) 964-7463

Or send check or money order to:
GREER ENTERPRISES
1810 E. Jarvis
Milwaukee, WI 53211

TECHNICAL TALK

Technical articles written by subscribers may recommend procedures or parts not approved by Saab-Scania of America, Inc. The Saab Club of North America cannot stand behind the correctness of information in these articles, but offers them based solely on the experiences of the writers.

CLEAN YOUR PLATES

Very few car batteries are replaced because they stop working, in almost every case the battery is replaced because it doesn't work well enough any more. What is not generally realized is that something can be done at this stage which may well prolong the useful life of the battery, quite often by many years, and that the same treatment carried out earlier in the battery's life may well have stopped the symptoms from occurring in the first place.

The reason for a battery failing to work properly any more is due to the chemical processes which take place within each cell when the battery is not fully charged. Even the slightest of discharged conditions allows both plates to react slowly with the sulfuric acid electrolyte to form lead ions. It is these lead ions which cause problems, they combine with sulfate ions in sulfuric acid to form highly insoluble lead sulfate. When this coats the plates of the battery, it fails to deliver enough power to be of use. The battery may well be thoroughly serviceable in every other way -- only the "sulfating" stops the battery delivering enough power to start the car.

The sulfating can effectively be removed, or prevented, by adding to each cell a chemical called tetrasodium ethylenediaminetetraacetate (abbreviated tetrasodium EDTA). This chemical forms co-ordination compounds with many metal ions, including the lead ions formed in the discharge cycle of a battery. The compound formed by lead ions and the EDTA ion is not particularly stable in the acid medium of a battery, but when it breaks down again any lead sulfate regenerated tends to drop to the bottom of the cell where it lays harmlessly since it doesn't conduct electricity. Any regenerated EDTA ions are free to continue their work.

As can be seen from above, treating a battery with tetrasodium EDTA is likely to be most effective when the battery, for one reason or another, spends periods when it is not fully charged, and so contains too many lead ions. This is likely to occur if the car is used for just short trips, is infrequently used, or has at any time suffered from an inefficient generator/alternator. Treating with the chemical can also help keep an original battery in use, and can help in bringing back into use a stored battery.

To treat a battery with tetrasodium EDTA you simply take a fully heaped tablespoon full of the powder, divide it up and add to each cell. This assumes an average size of battery but the exact amount is in no way critical. What you should then do is use the car normally for a few days, or agitate the battery frequently for a few days, and then give it a thorough charge to build up on the cleaned plate areas. On the assumption that sulfating has been affecting the performance of your battery, an increased performance will be noted from here on.

Over the past few years, many thousands of European car enthusiasts have used tetrasodium EDTA with great success on their batteries. You may wish to do the same by purchasing some of the chemical and giving it a try. If you cannot find any tetrasodium EDTA in your locality, I can provide you with enough to treat a battery for \$5.00 inclusive of air mail postage and packing. I can readily accept a personal cheque made out in U.S. dollars.

K. L. Martin
19 Brookmead
Meppershall
Sheffield
Bedfordshire
SG17 5SA
Great Britain

A CURE FOR SQUEALING BRAKES

June marks the second anniversary of my 1985 900 16V Turbo and my wife's 1985 900S. This milestone marks the end of those awful dirty Turbo wheels and those ear splitting, screechy brakes. For two wonderful years we've enjoyed these machines for everything they offer except the brake complaints that SAAB either cannot or does not choose to correct (they stopped replacing pads to cure the problem in '86). Somewhere between '83 and '85, Saab tinkered with the brake material. My '83 Turbo never displayed this type of brake squeal.

Several years ago, there was a letter to the technical editor of one of the many car magazines we all read, that told of a Volvo owner and his quest for the solution to the same problem we face. He wrote of his success with Repco brake pads. No dust, no squeal, and more than 50,000 miles on the pads. The editor replied that Repco was a reputable, Australian based company, that manufactured a quality product. What more could you ask for?

Two years ago I read that letter, and two years I suffered the noise and the dirt. It's now three weeks since the Repco pads have been installed on the Turbo. Absolutely NO noise. Virtually no brake dust! The amount of dust found on the wheels after a week of driving is now less than what used to result from one day of driving. Those of you who don't have the new style of wheels probably can't relate. The results are amazing!

I obtained the Repco pads through an AutoWeek advertiser:

Sebring Automotive Enterprises
127-11 94th Ave.
Richmond Hill, NY 11419
1-800-248-1133
1-718-849-1501

Their prompt, courteous, and speedy service deserves mention.

Front and rear pads ran about \$37.00 which included UPS shipping.

One more thing -- save your money on wheel cleaner. If you don't let your wheels get too dirty, Windex will clean them just as well as any commercial wheel cleaner. Use the blue stuff that contains ammonia. The cleaner made with vinegar won't work. If your wheels are really bad, use the commercial stuff.

Art Chapman
Old Bridge, NJ

CHECK THE EASY STUFF FIRST

If you should see coolant dripping from the vicinity of your water pump, don't assume the worst as I almost did on my '80 900 Turbo. Upon seeing a drip from this area and feeling the flow of coolant just below the pump, I almost removed the alternator, intake manifold and various hoses which must be done to get to the water pump. Laziness prevailed, however, and I searched around for an easier solution. Eureka! Just forward of the water pump is a very sharp flashing on the head casting itself. This had worn a hole in the heater inlet hose which caused a leak appearing to come from the pump itself. This section of hose is protected by a rubber sleeve to prevent this, but after seven years of vibration the sleeve had shifted. The obvious leak was preceded by a whining noise which appeared to be the heater valve since it would disappear if the heater valve position was changed. The noise has now gone after replacement of the inlet hose.

Ray M. Hull
Mercer Island, WA

FOG LIGHT PROTECTION

As a seasoned veteran at destroying fog lights, I have an alternative to replacing broken lenses (at \$32 a shot it gets expensive). Put a cover over them and save them.

I started out with fashioning a chicken-wire screen, the strongest screening I could find, and fit it to the fog lights. Though unattractive, it worked. The housing pivoted but the lens did not break.

Then I graduated to a clear cover. This was made for a four-headlamp system for square lights. They fit well on my Carello fog lights. I made a strap that secured them to the fog lights. These were much more attractive, yet still not expensive.

David Mondocar
Atlanta, GA

STRIPPED OIL DRAIN PLUG

When my niece stripped the threads on her '72 99 drain plug, I called all over Milwaukee to locate a replacement. The dealer only stocks the standard plug. The parts person joked about replacing the transmission housing since it was the housing and not the plug whose threads were stripped. In hopes of making an American plug fit I bought self tapping plugs (2 of them) from a local Monarch parts supplier. They worked for an oil change or two but soon lost their bite. What to do? Next we tried the rubber stopper insert which sells for around \$5, only to find that the Saab transmission housing is too thick for the stopper to expand inside the transmission.

Finally, I recalled that some of the Saab bolts are German Metric. None of the foreign auto part houses had a German metric bolt the size of a Saab drain plug. Then I called the Berndt Mercedes dealer parts person, Gary. I told him the approximate dimensions of my stock plug and asked if Mercedes had any plugs which would reach approximately 1/2" to 3/4" farther into the transmission case. From a look at a '70 99 transmission I've been storing pending overhaul, I learned that Saab does thread the oil drain hole well beyond the standard plug's reach. Gary suggested checking with his selection of Mercedes drain plugs.

He discovered a 14mm x 1.5 (German metric thread pitch) bolt which is common on the 1984 through present Mercedes Benz 190D. This is a smaller bodied M-B diesel sedan that was only recently introduced in America. The plug sold for under \$3. Due to its longer (23mm) shank to end length, I suggest that you get several washers to take up the slack. It would be a tragedy to screw it so far home that it would bear up against an unwary connecting rod.

Bill Hustedde
Milwaukee, WI

SPG PRODUCTION FIGURES

Since I own a 1985 900 Turbo SPG and was interested in the total production numbers and U.S. imports of that model I recently wrote to Robert Sinclair, president of Saab-Scania of America, and received the following information in a gracious reply from him. He noted that his reply was delayed as he had to get the information from Sweden.

1985 - 3621 produced, 1469 to U.S.

1986 - 2818 produced, 1498 to U.S.

1987 - 2132 produced, 1017 to U.S.

(projected figures)

Mr. Sinclair also noted that his personal car is a 1987 SPG that he enjoys immensely.

I am in the process of switching from a fun car (my SPG) and everyday car (a Toyota Camry) to one that should do both, a 9000, preferably Turbo, automatic. So my SPG is for sale (see ad in June issue).

Roland Halper
Laguna Niguel, CA

9000 FAN MAIL

Last month my 9000 Turbo reached its first birthday and it still runs as fantastic as when the odometer read 000000. I live in the Federal Republic of Germany where the Saab can show its true performance. At speeds of 135mph it is running rock steady and is very responsive to any abrupt evasive moves that might occur. These Saab engineers knew what they were doing. Since I am a serious driver and a demander of performance to include fuel efficiency, I am very satisfied and have no complaints.

Don Coe
APO, NY

A few notes on my '86 9000 at 43,000 miles.

Warranty repairs -- transmission o-ring was defective, leak at oil pressure gauge, seat heater replaced. Both my front wheel hub center nuts came loose. I used some Loctite to keep them secure.

I kept watching the front brake pads and they are still good. The rears recently went metal to metal because I did not check them. What I failed to take into account was that the hand brake works off the rear brakes on the 9000. I had left the hand brake on a few times before noticing the red signal on the dash. The rear discs are very thin on the 9000 and Peterson Automotive (Skokie, IL) suggested sanding rather than turning the discs. My rear brakes work well after the sanding.

At 30,000, I changed the plugs, fuel filter and air filter myself and I have yet to spend anything on a tuneup.

I was happy to see how well the 9000 held up in the Alabama high speed test because I drive my car hard and fast.

Paul Niedringhaus
Northbrook, IL

IMPORT MOTOR PARTS WAREHOUSE DISTRIBUTOR

110 West Twelfth Street / Pueblo, Colorado 81003

(303) 542-7025 - SK FC
52077

BOSCH

Original Bosch Fuel Injection Parts		
69-74 99E, 99EMS All	Fuel Pump GFF270	\$109.63ea
75-81 99 & 900 All	Fuel Pump GFF213	\$105.75ea
82-86 900, Turbo to 84	Fuel Pump GFF202	\$166.47ea
75-77 99	Fuel Dist FD10X	\$153.00ea
78-81 99, 900 Turbo	Fuel Dist FD23X	\$175.00ea
78-81 99, 900 Non Turbo	Fuel Dist FD18X	\$158.00ea
82-86 900 Turbo to 84	Fuel Dist FD30X	\$190.00ea
78-80 All Turbo	Wearup Reg 0438140051	\$89.92ea
76-80 All NonTurbo	Wearup Reg 0438140020	\$68.62ea
81-83 All	Wearup Reg 0438140084	\$123.92ea
75-80 All	Injectors 0437502004	\$16.88ea
81-86 All	Injectors 0437502012	\$17.63ea
80-4/85 All	Fuel Filter 0450905401	\$11.97ea
77-86 All	Lambda Sensor 0258001026	\$41.60ea
75-80 All	Cold Start Valve 0280170401	\$30.12ea
69-74 All	Trigger Contacts 1220090005	\$30.15ea
79-80 All	Fuel Accumulator 0438170010	\$58.75ea
67-74 Various	Alternator AL95X	\$59.95ea
74-4/78 NonTurbo	Alternator AL96X	\$87.00ea
5/78-80 99 Turbo	Alternator AL36X	\$123.95ea
79-80 900 NonTurbo	Alternator AL112X	\$84.95ea
70-74 99 All	Starter 5R77X	\$72.95ea
75-84 99, 900 All	Starter 5R78X	\$80.00ea

SACHS

Original Clutches (All new parts!!!)			
69on 99&900 NonTurbo	Plate 3082 100 041	\$41.06ea	
77-	99&900 Turbo	Plate 1850 480 043	\$73.15ea
69on 99&900 NonTurbo	Disc 1861 688 042	\$45.13ea	
77-	99&900 Turbo	Disc 1861 717 003	\$93.18ea
69-75 99 All	Brg. 1850 282 622	\$29.12ea	
76on 99&900 All	Brg. 1850 282 744	\$10.99ea	

BILSTEIN

Shocks And Struts		
67-84 96, 97, 99 All	Front Shock B46-0385	\$59.36ea
67-74 96, 97	Rear Shock B46-0393	\$52.69ea
68-7/78 99 All	Rear Shock B46-0395	\$59.36ea
8/78-85 99, 900 All	Rear Shock B46-0397	\$59.36ea
7/78-85 900 All	Front Shock B46-0387	\$59.36ea

MONTHLY SPECIALS

Miscellaneous Saab Parts		
69-74 96V4 & 99	Heater Cyl 25-09107	\$65.38ea
75-84 99 & 900 All	Heater Cyl 25-09108	\$103.25ea
69-76 99(8 cog gear)	Water Pump 28-09103	\$69.13ea
77-80 99 & 900 All	Water Pump 28-09105	\$56.54ea
79-84 900 & Turbo	Wolf Bra B7702	\$77.50ea

AND MUCH MUCH MORE
Note: We carry complete lines of Bosch, Bilstein, Sachs, and other parts for imported cars including Saabs. If you don't see what you need, give us a call, and we will help you get hard to find parts with easy to swallow prices.

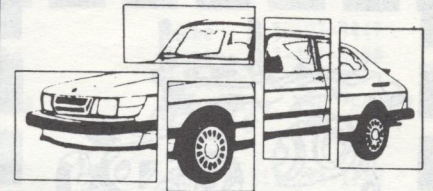

PARTS

EUROPEAN
AUTOTEILE
INC

DISCOUNT PRICES ON
NEW, USED, REBUILT PARTS & ACCESSORIES

- BODY PANELS
- ENGINES
- TRANSMISSIONS
- UPHOLSTERY
- SUSPENSION COMPONENTS
- CLUTCH KITS
- TURBOCHARGERS
- COMPLETE LINE OF ACCESSORIES

EVERYTHING FOR YOUR SAAB!

WE SHIP DAILY • OPEN SATURDAY

1311 67th ST. • EMERYVILLE, CA 94608

(415) 654-9121

ANDREWS INC. OF PRINCETON



**BACK IN THE
PARTS & SERVICE
BUSINESS AGAIN**

**8 AM — 5:30 PM
(CENTRAL TIME)
MONDAY THRU FRIDAY**

**3 BRICKTON ROAD
RTE. 4 BOX 247
PRINCETON, MN 55371**

612-389-3805

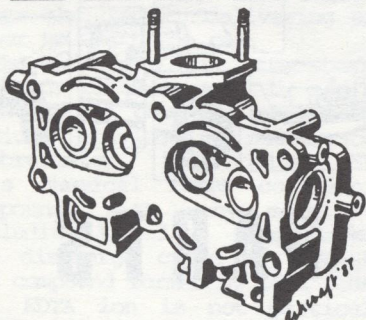

V4 HEADS RECONDITIONED

Includes new hard exhaust valves and seats, new intake valves, new valve springs and keepers, and new guides if required, on two Saab V4 heads. These heads OK for unleaded gasoline.

\$295

Exchange, plus shipping.

Add \$50 core charge per head, refundable if your heads are rebuildable.

**JACK ASHCRAFT
AUTOMOTIVE DESIGN
270 WILSON ROAD
CENTRAL POINT, OREGON 97502
503-779-0731**

ADVERTISE IN NINES
with your Business Card
Call (218) 525-3253
for rates.

CONVENTION SWAP MEET

Want to swap or sell any Saab merchandise, parts, accessories, books or just Saab memorabilia? Bring it to the Saab Owners National Convention on July 25th, 8:00am to Noon, inside with air conditioning. It will be a big four hour "buy it quick or lose it" sale!

No charge for space, tables or chairs. You can even bring small trailers into the building if you notify us in advance. For available space call Jim Glavas, 918-663-8087.

WEST COAST CONVOY?

California Saab Fans -- going to the Tulsa Convention? Tom Remedios will be driving there and is interested in setting up a "Saab Convention Convoy". Traveling in a group is always fun, and helpful if problems should arise. Tom would like to leave the San Francisco area between the 18th & 20th and do some sightseeing along the way. His passenger seat is also open, so a "gas fund" helper would be a possibility. You can contact Tom at home (408) 866-1689, or work (408) 432-9400 extension 2380.

CRASH TESTS

continued from pg. 1

behavior. A properly latched front seat does not move from the preset position under such test conditions according to Saab-Scania's own extensive crash test experiences. NHTSA has thoroughly investigated this aspect of the test and has determined that there was no safety defect or failure to comply with applicable standards.

"Consumer Reports apparently felt qualified to report on the 1986 crash test after reading the government test report and viewing the film records. To my knowledge

they did not inspect the test car nor were they advised by NHTSA that we had submitted evidence indicating the driver's seat was not latched properly. The Consumer Reports article contained statements which range from simple exaggeration ("the floor crumpled") to complete falsehood ("both front seatbacks failed"). The performance of the steering wheel and column in fact helped reduce the "injury" readings on the driver dummy considerably in view of the fact that the seat was not latched.

"NHTSA announced it would test a 1987 Saab 9000 in this year's New Car Assessment Program, the official title of its experimental crash test program. It is highly unusual for the agency to select the same model two years running, especially from a relatively low volume manufacturer. We believe this decision is in response to our findings with respect to the 1986 test. The new test was conducted on April 29, 1987 at NHTSA's test facility and was witnessed by Saab engineers.

"Due to the fact that the results of the new government test won't become available to the public until the Summer of 1987, Saab-Scania has decided to disclose the results of the five confirmatory tests it has recently conducted with identically equipped Saab 9000's, at 35 mph, and under the same conditions as the tests conducted under the auspices of the NHTSA. In each of these tests, involving vehicles taken from the ports where they were awaiting shipment to the U.S., the injury criteria numbers were below the maximum permissible NHTSA injury criteria for frontal barrier crashes at 30 mph. The forthcoming results of the new NHTSA test are expected to be comparable.

"The table below shows the mean values obtained from the five representative tests conducted by Saab-Scania compared to the NHTSA injury criteria limits permitted under the federal standards of protection in 30 mph crash tests. (A 35 mph barrier impact is one third more severe than on at 30 mph.) These are better than average results according to Consumer Reports' own rating method."

	Saab 9000 Average Results at 35 mph	Maximum Permissible NHTSA Injury Criteria at 30 mph
Head injury criterion (HIC) driver/passenger	589/621	1000/1000
Chest deceleration (g's) driver/passenger	48/40	60/60
Femur load (lbf) driver left/right	674/967	2250/2250
passenger left/right	450/315	2250/2250

SAAB CLUB ASSISTANCE NETWORK

Update to list published April 1987

	MI Randall Bauer 2725 Redwood Apt 8 Kalamazoo MI 49007	Home - 616-381-1218 Work - Categories - ABCDE 99s
CA Karl & Katie Guntheroth 200 Valley Home, #8 La Habra CA 90631	Home - 213-694-3937 Work - Categories - ABCDE Sonett, 99 & 900	
CA Bob Hall 215 Waverley #4 Menlo Park CA 94025	Home - 415-326-3715 Work - 415-858-2525 Categories - ABC 900s	
CO David Nichols 29791 Kings Valley East Conifer CO 80433	Home - 303-838-7674 Work - 303-985-3332 Categories - ABCE 900s	
CT Michael Caro 278 Boston Post Rd Orange CT 06477	Home - 203-469-5420 Work - 203-795-0776 Categories - ABCE 99s & 900s	
DE Edward Carney III 218 Reamer Ave Wilmington DE 19804	Home - 302-999-8796 Work - Categories - ABC 96, 99	
IL Jim Lamkin 2223 Willow Knolls #206 Peoria IL 61614	Home - 309-691-3308 Work - 309-692-5252 Categories - ABCE 2 strokes, 99s, 900s	
MD Thomas Cox Jr 3609 Hernwood Rd Woodstock MD 21163	Home - 301-465-6691 Work - Categories - AB 95/96, 97	
ME Joe Cleaves 485 Main St. Dexter ME 04930	Home - 207-924-7028 Work - Categories - ABCE 99s & 900s	
MI Nick Kohn 907 Pleasant St Belding MI 48809	Home - 616-794-1389 Work - Categories - ABCDE 96s, 99s, 900s	
MI Dave Nelson Gilson St Edmore MI 48829	Home - 517-427-5589 Work - Categories - ABCDE 96s, 99s, 900s	
MI Cy Hansen 316 Mill St Stanton MI 48888	Home - 517-831-5593 Work - Categories - ABCDE 96s, 99s, 900s	
MI Eric Hansen 750 Hemingway Dr Stanton MI 48888	Home - 517-762-5473 Work - 517-831-5852 Categories - ABCDE 96s, 99s, 900s	
NC Sam Shingleton 10-D Post Oak Rd. Durham NC 27705		Home - 919-383-7003 Work - 919-684-2206 Categories - ABCDE 2 strokes, V4s, 99s
ND Larry Larsen 217 - 7th St E Watford City ND 58854		Home - 701-842-6031 Work - 701-842-2410 Categories - ABCDE 99s & Sonetts
NY Barry Mabel 8-10 Pevster St Albany NY 12208		Home - 518-459-2321 Work - 518-474-4991 Categories - ABCDE V4s
NY Tony & Wendy Gounalis 9 Wellington Dr Endicott NY 13760		Home - 607-751-4332 Work - 607-785-3667 Categories - ABCE V4s & 900s
NY Jim Richards 4450 Main St. Gasport NY 14067		Home - 716-772-7939 Work - Categories - ABCE 96s, Sonetts, 99s
OH Dan Schindler The Swedish Solution 27999 Miles Rd. Chagrin Falls OH 44022		Home - Work - 216-248-1022 Categories - ABCE Saab repair shop
OH Gerald Whitaker 10581 Harrison Rd Loveland OH 45140		Home - 513-683-9447 Work - 513-489-5400 Categories - ABE 2 strokes, V4s, Sonetts
OH David Brown 219 Shadowlawn Ave. Dayton OH 45419		Home - 513-294-1758 Work - 513-253-9572 Categories - ABCE
OK Jim Glavas 2705 S. 74th East Av. Tulsa OK 74129		Home - 918-663-8087 Work - Categories -
OR Will E. McBride PE 2529 SE 14th Ave Portland OR 97202		Home - 503-231-7753 Work - 503-289-7905 Categories - ABCE 95, 96, 97
PA Tim Meyer RD1 Griffith Rd Cambridge Spgs PA 16403		Home - 814-398-8584 Work - Categories - ABCE
PA Brian O Shea RD 3 Box 38F Wellsboro PA 16901		Home - 717-724-2232 Work - 717-724-3858 Categories - ABCDE 96 & parts

- PA Glenn Rowe
RD 2 Box 312
Hershey PA 17033
Home - 717-533-8122
Work - 717-783-3377
Categories - AC
- PA Keith Hollander
407 St. Ann's Circle
Kimberton PA 19442
Home -
Work - 337-2070
Categories - ABCDE
- RI Arthur Huddle
132 Phillips Ave
Warwick RI 02888
Home - 781-4067
Work - 353-1260
Categories - AC
3 yrs Saab Master Mechanic
- WI Mike Etzel
5052 N. 127th St.
Butler WI 53007
Home - 414-781-8922
Work - 414-771-2340
Categories - ABCD
All models, Pts Mgr at Tosa
- WI Adam Monzingo
2356A N. 65th St.
Wauwatosa WI 53213
Home - 414-774-0405
Work - 414-771-2340
Categories - ABCD
Asst Pts Mgr at Tosa
- WI Tosa Imports
6102 W. North Av.
Milwaukee WI 53213
USA 1-800-225-2528
WISC 1-800-242-2003
Categories - ABCDE
Saab dealer, all models
- WI Dale Roble
6943 Hwy B
Pittsville WI 54466
Home - 715-884-2786
Work -
Categories - ABCDE
All
- WI Steven Muther
1417 Bowen St
Oshkosh WI 54901
Home - 414-233-5329
Work -
Categories - BCE
900s

CANADA

- ONT Norman Leslie
22 Banstock Dr
Willowdale ONT M2K 2H6
Home - 416-229-6797
Work - 416-676-1191
Categories - A

EUROPE

- Michael Voronyak
Steinstrasse #8
5449 Beltheim
WEST GERMANY
Home - 011 49 06762 8543
Work -
Categories -

MECHANICS LIST

Update to list
published May 1987

- CA Scandia Auto Imports
14021 E. Whittier Blvd
Whittier CA 90600
213-698-0547
714-739-8804
Ind. Saab repair
- CA Saab/Volvo Service
8822 Norwalk Blvd
Santa Fe Springs CA 90670-
213-699-6568
- CO Prestige Automotive
Huba Topai
1917 N. 1st St.
Grand Junction CO 81503
303-242-5260
Ind. Saab repair
- HI Finesse Engineering
1130 N. Nimitz Hwy.
Honolulu HI 96817
524-8945
- ME Coldbrook Saab
Glen Holden
Parts Mgr: Dan Richardson
Upper Madison Ave.
Skowhegan ME 04976
207-474-9881
Saab dealer
- NC Eurasian Import Center
Charles 'Bucky' Curtis
105 W. Greenville Blvd.
Greenville NC 27834
(919) 756-2705
Ind. repair shop
- NY L.I.C. Auto Imports, Inc.
J. Giaino
28-39 Thirty-first St.
Astoria NY 11102
718-932-6003
Saab dealer
- OH The Swedish Solution Inc.
Dan Schindler
Parts Mgr: Matt Titus
Mechanics: Bob, David, Gary, Clay
27999 Miles Road
Orange Village OH 44022
216-248-1022
24 hour phone answering
Ind. Saab Parts & Service
Hours: M-Th 8am-7pm, Fr 8-5
- PA PARRformance
Rick Parr
Parts Mgr: Trevor Thomas
Mechanics: Tim Brown, Tony Aeillo
243 S. Broad St.
Lititz PA 17543
717-627-7222 (-SAAB)
Ind. Saab & Volvo repair
New & used parts
- UT Shields Foreign Car Center
1190 S. State St.
Salt Lake City UT 84100
534-0701

CLOSEOUT ON CONVENTION GOODIES

- '86 T-Shirts(M, XL only) _____ \$6.00
"Troll" T-Shirts (M, L, XL) _____ \$7.00
'86 Convention Posters _____ \$2.00
"SAAB CLUBS" Lic. Plate _____ \$4.00
"SAAB CLUBS" Lic. Bracket _____ \$3.00
(Specify Model & Year)

Add \$2.00 Shipping Per Order.
Send To:

SAAB CLUBS OF GEORGIA
1491 Howell Mill Road
Atlanta, GA 30318

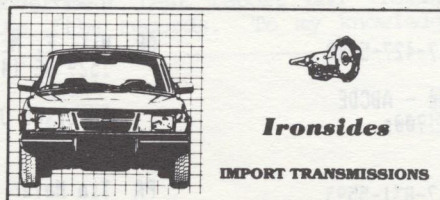

SAAB OWNERS, if your transmission has gone its last mile, we can be of service to you! We specialize in the remanufacture of transmissions. If you're driving on borrowed time or your vehicle is "down and out", let us put you back on the road. All work guaranteed. Ironsides Drive-Train Corp. 14 Court Street, Freehold, NJ 07728, 201-308-3171.

ADLERS HONORED BY BRITS

British Saab club members Tony and Meta Percy paid a visit to the U.S. recently, specifically to the Midwest, staying with Milt and Margrit Adler and with Monty Tarr's family. The Central Illiana Saab Club and several members of the Northern Illinois Saab Club got together with the Percys for dinner on May 23rd to discuss the differences and similarities of Saabs and Clubs in Europe and in the U.S. A blue and yellow floral display in the design of a Swedish flag represented the common bond of the participants.

Tony Percy took the opportunity to present the Adlers with two gifts crafted by Ken Isherwood of the Saab Owners Club of Great Britain; a hand turned wooden bowl from the Saab Midlands Auto Club, and a ceramic bowl, a duplicate of one presented to the Earl of Bradford in Weston Park to mark the visit of the Saab Owners Club on their National Rally in 1983. Milt and Margrit Adler have long been supporters of the Saab marque and Saab Clubs in this country, and the honor was certainly well deserved.

SAAB ACCESSORIES SALE

Adam Monzingo from the parts department at Tosa Imports sent in a copy of Saab accessory items that have been drastically reduced in price so Saab won't have to move them to their new warehouse. The list includes spoilers, wheels, clothing, steering wheels, and many other things from Saab's Accessories catalog. These specially priced items are available through any Saab dealer, but Tosa will sell them at minimum markup to Saab club members.

COMBINED ISSUE NEXT

The next issue of NINES that you will receive is August/September, our normal "combined" issue for the year. It will be mailed in late August, so the deadlines for ads and articles are extended by two weeks (which hopefully means they'll get here on time for a change).

This special issue will feature tales of the National Saab Owners Convention in Tulsa, Oklahoma. Those of you who attend will already know most of it, but there are always some stories that don't make it into the newsletter ("Ya just hadda be there!" and "Wink, wink, nudge, nudge, know what I mean?").

BACK ISSUES RUNNING OUT

Due to the rapid growth of the Saab Club over the past several months (about 100 new members per month), and the number of new members who purchase the Back Issue Collection, the stacks of previous issues of NINES are becoming rapidly depleted. As of this writing, we have only the following issues in stock:

Jan thru May '86
Dec. '86
Feb thru June '87

We are now collecting the Tech Tips from past issues to put in books specifically for 2-stroke and V4 models, and for 99 and 900 models. It could be as long as a year before these books are ready for publication.

TALLADEGA MUSEUM GETS 9000

The International Motorsports Hall of Fame and Museum at the Alabama International Speedway in Talladega recently added a new car to its

collection when Saab donated one of its 9000 Turbos which took part in last year's "Long Run" endurance test at the speedway.

Transfer of the car to the museum was witnessed by a crowd of 135-thousand during the NASCAR Winston 500 auto race. Other than the famous British land speed record car, the Bluebird, the Saab becomes the only other foreign manufactured world-record setting car enshrined in the museum.



207 E CHURCH STREET
LIGONIER, PA 15658
412-238-4556

DENNIS SWEENEY
SAAB PARTS SPECIALIST

ROADSPORT

MOTORING ACCESSORIES

900,9000 DEAD PEDAL
Provides a comfortable place to rest your foot next to clutch without damaging your carpet. Fits all years **19.50**

87 900,9000 BULB
9004 Replacement headlight bulb for composite lights **9.50**

ROADSPORT

8351 Roswell Road
Suite 140
Dunwoody, GA 30338

(GA RESIDENTS ADD 5%)

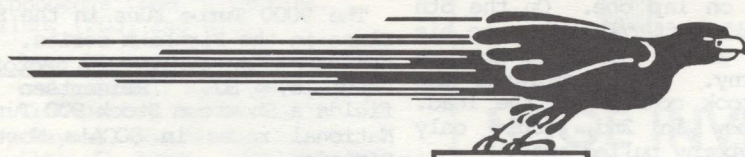

SAAB
PARTS

Genuine SAAB Parts

at
Discount Prices

JACK SAFRO

TOSA IMPORTS

6102 WEST NORTH AVENUE • MILWAUKEE, WI 53213

1-800-242-2003 1-800-225-2528

BOB YATES

IMPORT CAR SPECIALISTS

- * Genuine SAAB factory parts
- * Club discount
- * Knowledgeable, fast and friendly service
- * NOW AVAILABLE!! - Direct shipment from SAAB to you. Ask for details.

CALL:

215-752-3000

Rt. 1 & I-95
Langhorne, PA 19047

SAAB PERFORMANCE

WEBER "BIG THROAT" FOR
99 & 900 75 & up \$195.00

WEBER 34 ICH 1 BBL CARB
FOR V-4, INCL. LINKAGE .. \$150

Call for info on
Weber 32/36 kit for early 99s

SPORT CLUTCH PACKAGE — For
99/900; Rally, Autocross. or
towing. Pkg. includes Disk,
Pressure Plate and Bearing.
'69 - '75 \$105.00
'76 - '83 \$95.00

KYB Gas-a-just shocks for
96, Sonett, 99, 900

We stock camshaft and
balance shaft bearings
for V4s

— PLUS UPS —

MASTERCARD & VISA ACCEPTED

SWEDISH EXPRESS, INC.

335 S. 1st Avenue East
Duluth, MN 55802
(218) 722-1530



Sunlight Reflecting Shields That Keep Your Car Cool!

- Sun Stop installs in seconds to the inside of your windshield.
- Reduces interior temperatures in parked and locked cars.
- Attractive metallic ripstop nylon fabric keeps dash and seats cool while preventing fading of upholstery.
- Stores in its own neat pouch when not in use.
- Custom fit for your car and guaranteed.

State make, model and year.

\$39.95 includes postage and handling
(CT. residents add sales tax).

Send check to:

SUN PRODUCTS, INC.
P.O. Box 202
Middletown,
CT 06457

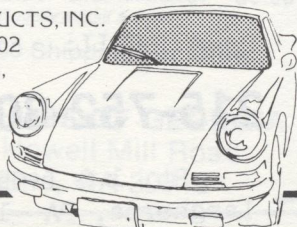

MURILLO LEADS BARBER-SAAB

Ken Murillo carries a slim lead one-third of the way through the 1987 Barber Saab Pro Series. Murillo, of San Ramon, California, has two wins and a second place for a total of 55 points after four races. Bruce Feldman and Jeremy Dale have each won a race and are second and third in points respectively.

MIAMI, FL -- Ken Murillo threw off challenges by Jeremy Dale and Bruce Feldman to win the season opening Finlay HMO Barber Saab Pro Series Race on March 1st, held in conjunction with IMSA's Miami Grand Prix. Murillo started the race from the pole position in his Red Line Oil sponsored car.

As the field of 25 starters took the green in their identically prepared, BFGoodrich-shod formula race cars, Jeremy Dale made an excellent start, ending the first lap in the lead. But it wasn't long before Dale was passed by Murillo, then Feldman. Series newcomer Mark Wyborny quickly followed the leaders, relegating Dale to 4th place.

Quite a few laps were run under the yellow flag due to crashes on the narrow street circuit. In the end, Murillo finished 0.35 seconds ahead of Feldman. Wyborny held on to his third place position at the checkered flag. Rounding out the top five were Dale and Greg Hobbs, son of famed race driver (and TV race commentator) David Hobbs.

ROAD ATLANTA, GA -- Starting from the 2nd position on the grid, Ken Murillo posted his second 1987 victory in as many outings. Murillo took the undisputed lead on the 15th of 20 laps.

Mark Wyborny had the pole position, but relinquished the lead to Tim Colwell, 4th fastest qualifier, on lap one. On the 5th lap, Colwell suffered damage to his front wing as the result of contact with Wyborny. Mark completed the pass and took command of the lead. Murillo, now in 2nd, could only watch as Wyborny pulled away.

But a cracked weld in the custom fabricated inlet pipe reduced the boost to the turbocharged Saab powered race car, and Murillo took the lead five laps from the finish. Wyborny managed to hold on to second place. Jeremy Dale, Bruce Feldman and Mark Brainard filled out the top five spots.

LIME ROCK PARK, CT -- For 22 of the 32 race laps, Bruce Feldman was involved in a seemingly futile chase of polesitter and series newcomer, Robbie Buhl. An ailing gearbox forced Buhl to retire just ten laps short of the checker, and Feldman took over the lead.

Jeremy Dale posted the fastest lap of the race as he charged to 5th place after being forced to the back of the pack by a "stop & go" penalty for jumping the start. The other top five finishers were: Tim

Colwell, Greg Hobbs, and Jeff Simpson. 1986 Barber Saab Pro Series champ Willy Lewis made his first start of the '87 season and finished 6th.

MID-OHIO -- Jeremy Dale took his first victory of 1987 with a flag-to-flag showing at the June 7th running of the Barber Saab Pro Series. Dale, who started second on the grid, won the race by 1.704 seconds over Ken Murillo. Robbie Buhl set a new track record in qualifying. Buhl's challenge of Dale for the lead was unceasing from the first lap until he was sidelined by a sheared throttle linkage.

Third place finisher, Tim Colwell, posted the fastest race lap. Greg Hobbs and Bruce Feldman filled the next two places at the end of the 20 lap race.

The remaining Barber Saab Pro Series races for 1987:

Summit Point, WV	7/12
Portland Int'l, OR	7/26
Sears Point, CA	8/2
Watkins Glen, NY	8/9
Road America, WI	8/30
San Antonio, TX	9/6
Watkins Glen, NY	9/27
Tamiami Park, FL	11/1

9000 TO CHALLENGE IN FIREHAWK

Reinertsen Motors Racing will take to racetracks in the Eastern U.S. in a Saab 9000 Turbo. The car will be a competitor in the IMSA Firestone Firehawk Series, made up of endurance races for showroom stock cars on street tires.

The Reinertsen team will appear at the following Firehawk events:

Road Atlanta, GA	6/27
Summit Point, WV	7/11
Lime Rock Park, CT	9/7
Watkins Glen, NY	9/26
Columbus, OH	
(street race)	10/3

The 9000 Turbo runs in the Sports Class in the Firehawk series. It is sponsored by Reinertsen Motors of Denville, NJ. Reinertsen also fields a Showroom Stock 900 Turbo in National races in SCCA's Northeast Division.

EDITOR TAKES E.T.W. PRIZE

Top Saab honors at the "Escape To Wisconsin" SCCA National Road Rally were taken by the team of Warren Harder and Tim Winker in Tim's '79 99GL. The rally, based in Menominee, covered nearly 300 miles of scenic Wisconsin hill country.



99, 900 & 9000 Parts, cont.

4 New SPG wheels w/caps, \$700.
4 new Pirelli P6 tires, \$375.
4 new 86 900T wheels, \$700. 87 900
Clarion sound sys, used 2 mos, \$800.
Michael Caro, 278 Boston Post Rd,
Orange, CT 06477. (203) 795-0776.

Transmissions, 4-spd & 5-spd.
Rebuilt turbos, all years.
Exhaust manifolds, cyl heads for "B"
& "H" engines. Set of SPG wheels.
Dennis Sweeney, 207 Church St,
Ligonier, PA 15658. (412) 238-4556.

WANTED. ALL MODELS

Pad to fit 96 headrest. Kevin
Rogers, Warwick, NY. (914) 986-5520
6-10pm.

5-bolt mags for Sonett, lugs for
mags, door chrome from 68 DeLuxe.
Willy McBride, 2529 SE 14th Ave,
Portland, OR 97202.
(503) 231-7753 (H), 289-7905 (W).

Anyone with knowledge of how to
obtain rear glass for 67-69 Sonett,
and/or 940 pistons/rings. Also have
misc 2-stroke cars & parts for sale.
Stephen Nicholoff, PO Box 2182.
Boulder, CO 80306. (303) 442-1913.

Momo leather steering wheel for
'80 900T, also want F & R bumper
covers, any type front air dam or
spoiler, covers for Hella 181s, tan
or brown sheepskin seatcovers. Larry
Hunt, Grissom AFB, IN. (317) 689-9473

A/C system to fit 72 99 & copy of
instructions. Lee Beck, 2015
Ontario Cir, Ft. Wayne, IN 46802.
(219) 426-6551 days or 432-0202 eves.

Sonett II windshield & Owners
Manual, Tekno 1/43rd scale die cast
SAAB 99 & 96/5 models & similar,
early & odd SAAB sales literature,
posters, calendars, etc.
Correspondence from collectors.
Rob Allen, (203) 248-8798.

Want late 95 body, any cond except
rusty, under \$1500. Also want V4
competition parts, new or used.
Shepley Haynes, 554 NE 7th Av,
Gainesville, FL 32601. (904) 342-5086

Backissues of Saab Club newsletter
to complete Club's set. Need all
prior to 2/75, plus 10/76, 2/77,
1/81, 2/84, 11-12/84. Copies OK.
Tim Winker, (218) 525-3253, 1v msg.

Any & all paraphenalia related to
Sonett II V4s, esp Service manuals,
literature. Also window winding mech
& interior drivers door panel. Mark
Welden, 1375 Kimberly Dr, San Jose,
CA 95118. (408) 265-2982.

Rt taillight & backup light assys
from '70 96. David Patton, 961
Anderson Cir, Heber Springs, AR
72543. (501) 362-2725.

Sunroof, grille, bumpers, &
interior for '71 Sonett. Have lots
of V4 parts to trade. John Fox,
Box 29626, Olympic Valley, CA 95730.

— DISCOUNT BOOK PROGRAM —

The Saab Club can now offer these books to its members at discounts of
10 - 20% below suggested retail.

SAAB TURBO 1976 - 1983

Brooklands Road Test collection
List \$12.95. CLUB PRICE \$11.00.

SAAB SONETT 1966 - 1974

Brooklands Road Test collection.
List \$8.95. CLUB PRICE \$7.50.

THE SONETT AND ALL OTHER SPORTS CARS by Bjorn Svallner

List, \$13.95. CLUB PRICE \$11.95.

SAAB TURBO by Graham Robson

List, \$14.95. CLUB PRICE \$11.95.

SAAB: THE INNOVATOR by Mark Chatterton

List, \$29.95. CLUB PRICE \$24.00.

CAR & DRIVER ON SAAB 1956 - 1985

List, \$12.95. CLUB PRICE \$11.00.

ROAD & TRACK ON SAAB 1955 - 1984

List, \$12.95. CLUB PRICE \$11.00.

FROM TWO-STROKE TO TURBO: SAAB IN MOTORSPORTS by Anders Tunberg

List, \$14.95. CLUB PRICE \$11.95

SUPERCARS - SAAB 9000

List, \$34.95. CLUB PRICE \$30.00.

HAYNES WORKSHOP MANUALS

95/96 (V4) 66 - 75
99, 69 - 79
900 (incl. Turbo), 79 - 85
List, \$14.95. CLUB PRICE \$12.00.

— Add \$2.50 per order for shipping — Sorry, no phone orders or CODs —

Send Check or Money Order for books to:

**The Saab Club
Discount Books
2416 London Road, #900
Duluth, Minnesota 55812**

SAAB PARTS



HUGE INVENTORY OF FACTORY PARTS AND ACCESSORIES FOR V-4, 99, 900 and 9000

**V-4 CATALOG, \$3.00
(REFUNDABLE)**

**ROWLAND
MOTORS**

517 East Pike Street
Seattle, WA 98122

"THE ENTHUSIAST PARTS STORE"

**SAAB
ROWLAND MOTORS**

U.S.A. PARTS ORDER LINE
1-800-426-2202
WA STATE PARTS ORDER LINE
1-800-562-5510
INFORMATION, SEATTLE LINE
(206) 328-2303

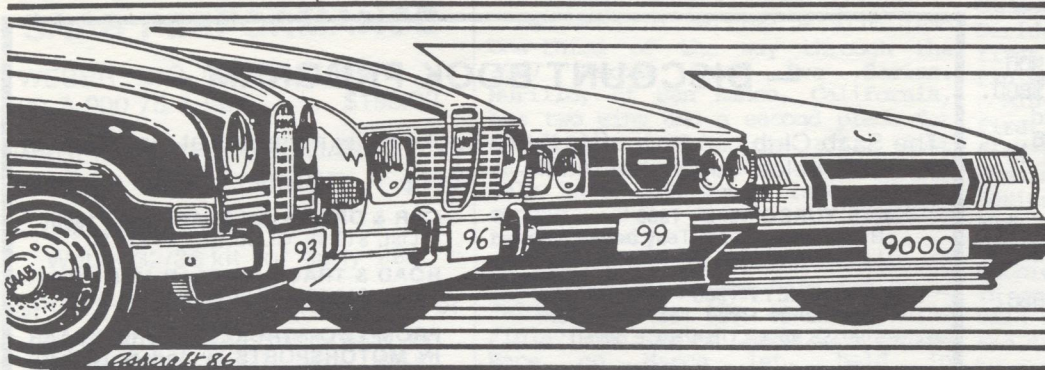

SAAB SWAP

CLASSIFIED ADS

CLASSIFIED AD RATES

Ads offering parts or Saabs for sale or wanted are available to members and non-members. Ads are limited to 25 words, plus name, address, and phone number. Ad copy will be abbreviated and excess words deleted where possible. Enclose sufficient funds with your ad, we will not bill. No ads will be taken by phone. The Classified ad rate is based on the total dollar amount listed in the ad.

Under \$200	Free
\$201 to \$900	\$2.00
\$901 to \$2000	\$5.00
Over \$2001	\$10.00
Ads without a price listed ...	\$10.00

DEADLINE: Second Friday of each month for the following month's issue, i.e. the second Friday in January for the February issue.

COMMERCIAL ADS: Contact Editor for rates and info. Deadline, First Friday of each month for the following month's issue.

SONETTS FOR SALE

'74 Sonett, 79k mi, new blue paint, exc cond in & out. Looks very clean, drives perfectly. \$5000. Joanne Piva, 565 San Benito Av, Los Gatos, CA 95030. (408) 354-7574.

'74 Sonett, 42k mi, yellow, interior & exterior in good shape. Runs good & no rust. \$4200. Joe Livingston, RD #1, Hartstown, PA 16131. (412) 927-2251.

'74 Sonett, Weber, AM/FM cass, Konis, Mint. \$3600. Also '73 Sonett, good body, rusty pan. \$1200. Joel Ballon, 479 Perry Hwy, Pittsburgh, PA 15229. (412) 931-2522.

'73 Sonett, 45k mi, Southern car, new 2551 Weber & manifold, Gislaved tires, Bilsteins, Bosch fogs, MSS heads & many new eng parts, Hi-perf distrib, rblt brakes, clutch, trans. \$6500 invested, asking \$4900 obo. Peter Briggs, 5 Riley St, Plainville, MA 02762. (617) 695-1656.

'73 Sonett, 100k mi, strong running, new shocks, CV joints, Midas custom exh, needs paint & interior work. Includes complete '72 Sonett parts car. \$3500 obo. Robert McLeod, 308 Elberta St, Cashmere, WA 98815. (509) 782-4100.

'73 Sonett, 40k orig mi on eng & trans, F/G damaged on nose, one headlight bucket gone, frame rusted. Good restoration or parts car. \$800. Ron Wood, Pittsford, NY. (716) 586-8867 or (315) 986-5019 (days).

'72 Sonett, 110k mi, needs clutch, everything else great. Same car advertised last month, but price lowered. \$2200 obo. Must sell. Tom Remedios, 1191 Bucknam Av, Campbell, CA 95008. (408) 866-1689, or (408) 432-9400 x.2380.

'72 Sonett, 90k mi, 2500 on rblt trans & eng. Big valves, ported, cam, MSS exh, Ferrari red. \$2600 obo. Also '71 Sonett, \$1000. Stephen Nicholoff, PO Box 2182, Boulder, CO 80306. (303) 442-1913.

'72 Sonett, 4000 mi on unleaded prepped & substantially modified V4, Swaybar, 195/60 Pirellis, much more. Good cond, needs paint. \$1500 firm. Robert Huettner Jr, RFD#4 Box 955, Weare, NH 03281. (603) 529-7731 eve.

93s, 95s & 96s FOR SALE

'73 96 V4, new yellow paint, new Weber, exh, brakes, new Saab black cloth seats. \$2000. Marc Lindy, 343 Ferndale, Birmingham, MI 48009. (313) 646-8343, or 559-5959.

'72 95, no rust, exc mech, new paint. Regretfully must sell. Spare engine & many spare parts. \$1800 obo. Bee Bailey, 9155 Hwy 101 N, Redwood Valley, CA. (707) 485-7478.

'71 95, Southern body, perfect for rebuilding, no rot, great interior, AC, many extras. \$500. Marc Lindy, 343 Ferndale, Birmingham, MI 48009. (313) 646-8343, or 559-5959.

'70 96, spent its life in the South & frozen North on SANDED, not salted, roads. Includes extra trans & parts. \$600 firm. Jeff Brain, RT 1 Box 173, Hancock, MI 49930. (906) 482-9121 eves.

'70 96, strong eng, Weber carb, body & interior fair, extra chrome bumpers. \$550. Charles Easter, 1207 Park, Ft. Wayne, IN 46807. (219) 456-1342, 6-10pm.

'68 95, Rebuilt trans, brakes, electrics. Rebuilt heads & new timing gears, water pump & fanshaft brng. Gorgeous new red paint, super interior, roof rack. \$3000. John Hurd, 1219 El Dorado, Klamath Falls, OR 97601. (503) 884-1734.

'68 96, yellow, exc body, no rust, brakes overhauled, runs good. Incl 67 parts car. \$895. Walter Williams, RT 1 Box 27A2, Crowley, TX 76036. (817) 297-9198.

'68 96 DLX w/72 trans, 71 eng, new paint, new tires. \$1600 obo or trade for 68-69 95. Send SASE to John Fox, Box 29626, Olympic Valley, CA 95730.

'67 Monte Carlo in running order. Someone needs to use this up. \$300. Robert Andrews, RR Box 143, Pennock, MN 56279.

'66 96, exc cond in & out. Garaged since '83, driven occasionally. Needs minor mech work, otherwise runs good. Original shop manuals, parts car avail. \$1200. Mike Mooneyham, 1031 E. 22nd Av, N Kansas City, MO 64116. (816) 421-4176.

'66 96 2-stroke, new red paint, exh, clutch. Runs good, interior remarkable. \$1000 obo. Marc Lindy, 343 Ferndale, Birmingham, MI 48009. (313) 646-8343, or 559-5959.

2-STROKE & V-4 PARTS FOR SALE

All Fiberglass for Sonett II. Used parts for 95, 96, 97, 99, 900. Baldwin Foreign Auto Repair, New Lebanon, NY 12125. (518) 794-8729.

'72 Sonett rear clip, from windshield aft, \$150. Doors, \$100 ea. Hatch, etc. Ray Gill, 1842 Emerald Av NE, Grand Rapids, MI 44505. (616) 363-3357.

Sonett III trans, all new brngs, synchros & seals, freewheel lockout, \$550 +core +shpg. Also, long lasting 2" bore exhaust systems for all 2-strokes, \$225 +shpg. Other misc parts for 95/96. Peter Bunn, PO Box 132, Barneveld, WI 53507.

95/96 windshield, \$35. Rear side windows from 96, \$30/pr. V4 radiator \$45. All +UPS. Bob Mitchell, 403 E. Redwood Av, Pleasantville, NJ 08232.

So Neat Stuff for Sonett IIIs: spoilers, louvers, etc. Send SASE to Re-Search, Rt 6 Box 84, Alexandria, MN 56308

850cc 3 cyl engine, 30k mi, \$195.
71-73 Brake Master Cylinder, \$30.
69-70 Brake MC rebuild kit, \$5.
Fan belts, \$1.50. Condenser, \$1.95.
Early style air filter, \$5. +shpg.
Willy McBride, 2529 SE 14th Ave,
Portland, OR 97202.
(503) 231-7753 (H), 289-7905 (W).

95/96/97 doors, glass, bumpers, misc parts. No shpg on large items. Send SASE with your detailed request (year, side, etc.). Make offer on whole lot. Paul Florance, 126-1/2 Main St, Seal Beach, CA 90740.

95/96 used parts. Parting out 20 cars, 2-stroke & V4. Send SASE or call. Shepley Haynes, 554 NE 7th Av, Gainesville, FL 32601. (904)372-5086

Dealer Parts Guide for 95/96. Written in 5 languages, has every part listing. Fits in 3-ring binder. Make offer. Kevin Rogers, Warwick, NY. (914) 986-5520 6-10pm.

Parting out 63 96. Also many later 2-stroke & V4 parts, good condition, low prices. Send SASE for list. John Ogilvy, 2423 Nation Av, Durham, NC 27707.

96 Trailer Hitch, \$40. Workshop manual, \$45. New fan & emergency brake cables, \$25ea. New 95 rear shock, \$45. All +shpg. Tom Burke, 48 Columbia St, Bangor, ME 04401. (207) 942-8872, 2-5:30pm M-F.

2 Steel wheels from 72 96, w/used 155R15 M+S tires. Both - \$15 +shpg. David Gangeness, 2916 Branch St, Duluth, MN 55812.

'72 Sonett trans, exc cond, freewheel starting to go. \$200. Robert Huettner Jr, RFD#4 Box 955, Weare, NH 03281. (603) 529-7731 eve.

99s & 900s FOR SALE

'86 900 SPG, 3000 mi, 5-spd, Clarion component sound system, leather, power roof, air flow kit, suspension pkg, mint, minor damage repaired by expert. \$16,000. Michael Caro, 278 Boston Post Rd, Orange, CT 06477. (203) 795-0776.

82-1/2 900T hatchback, 75k mi, APC, white w/burgundy interior, Sony AM/FM cass, fresh Pirelli P6, maintained by the book & garaged. Immaculate. \$6450 obo. James Newton, 4922 Greenway Dr, Bethesda, MD 20816. (301) 652-2060.

'80 GLE, black, S/R, mag wheels, stereo, good body, needs CV joint. 1st \$1500. Also good '80 B-eng & auto trans, \$200. Good 99 hood, \$50. Greg Helland, 17310 Abel Ln, Wayzata, MN 55391. (612) 476-1432.

'77 99GL, 5dr, 110k mi, body and interior good, S/R, AM-FM cass, KYB shocks, many new parts, needs head gskt? 60k on trans. Must sell, \$600. Ron Wood, Pittsford, NY. (716) 586-8867 or (315) 986-5019 days.

'76 99GL, 153k mi, good running cond. Extensively rebuilt - eng, trans. New battery, snow tires. AM/FM cass, minor rust & dent \$1950 obo. Patrick Gaffney, 11 Sharon Av, East Setauket, Long Island NY 11733. (516) 751-8573.

'73 99EMS, exceptional car, exc body & running cond, orig paint, very strong eng. Very well loved & cared for. Ask \$2800. Wendy Hill, Box 147, Harrisville, NH 03450. (603) 827-3875.

99, 900 & 9000 PARTS & ACCESSORIES

2.0L head from '77, gd cond, \$150 incl shpg. 2 Conti Contact M+S on rims, half worn. \$25 for both +shpg. David Gangeness, 2916 Branch St, Duluth, MN 55812.

Used 99 radiator, V4 tanks (some mod req) \$50. 900 radiator, \$50. Used turbo crank, \$50. All +UPS. Bob Mitchell, 403 E. Redwood Av, Pleasantville, NJ 08232.

99 car cover & bra, both in exc cond. Also UNGO box w/o mounting brkt & wiring. Factory Service Manual, hardly used. John Mekisich, 4636 Niland St, Union City, CA 94587. (415) 489-9371.

Clarion Saab AM/FM cass from 87 Turbo, 18 presets, code, 80w amp, spect anal, w/manual & removal tool. \$729. Mark Uhryk, 50 Lost Hollow, Dillsburg, PA 17019. (717) 432-9433.

900 Factory Service Manual, '79-'82, sections 0-6, \$50. McGard wheel locks for '82 alloys, \$20. Kevin Kelly, P.O. Box 1025, Denville, NJ 07834. (201) 670-9009.

OE TRX rims from 81 Turbo, exc cond, \$49ea +UPS or 4/\$175 incl UPS. Robert Harding, 1321 Monte Largo NE, Albuquerque, NM 87112. (505)293-5010

OE TRX wheels from 80 GLE, incl lug nuts & OE hubcaps, \$50ea or \$175/4. 4 small aluminum hub caps for 15" wheels, \$5ea. 2 orig mirrors for 75 99LE, \$15. All +UPS. Could bring them to Tulsa. Phillip Niemann, 7620 W. 52nd St, Overland Pk, KS 66202. (913) 262-5966.

Dash panel insert, \$35. Air flow temp sensor unit to eng air filter, \$19. Steel snow chains for TRX wheels, \$16. +shpg. Terry Parsons, San Jose, CA (408) 274-0301.

4 EMS Maqs, exc cond, w/Dunlop SP15, \$350. Workshop manual to '76, \$45. Workshop manual '77 on, \$45. +shpg. Tom Burke, 48 Columbia St, Bangor, ME 04401. (207) 942-8872, 2-5:30pm M-F. Don't leave msg.

900 thru 16 valve dismantled cars. 16v eng compl w/FI & turbo, wiring, intercooler, brain, etc. Drivetrains for 900 & Turbos, interiors, heads, manifolds, radiators, pwr strng, gauges, susp... Michael Caro, 278 Boston Post Rd, Orange, CT 06477. (203) 795-0776.

Continued on pg. 13

MEMBERSHIP/SUBSCRIPTION

NAME _____
ADDRESS _____
CITY _____ STATE _____ ZIP CODE _____
PHONE _____
SAABS OWNED _____
(Year & Model)

Please check appropriate box(es):

- FIRST YEAR \$18.00
- RENEWAL \$15.00
- CANADIAN Add \$3.00 U.S.
- INTERNATIONAL ... Add \$7.00 U.S.

Individual back issues (from Jan. '86 on; no June, Aug./Sept. left) are available for \$1.50 each; 3 or more \$1.00 each.

- Collection of 10+ back issues \$10.00
- SAAB Club Decals, \$1.00 each.

SEND TO:
SAAB CLUB OF NORTH AMERICA
2416 London Road, Unit 900
Duluth, Minnesota 55812-2221

1340 HARTFORD AVENUE
JOHNSTON, RI 02919
401-831-8850 in RI

**SPECIAL INTEREST
CARPARTS**

Call Toll Free 800-556-7496
or 800-851-5600 Today!
Monday-Friday 8:30-7:00 EST
Saturday 10:00-4:00 EST
Sunday WE REST!!!

SPECIAL INTEREST SPEAKS SWEDISH!!!



SAAB SPECIALS

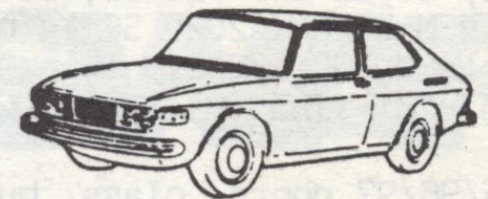

Description	Price
Lambda Sensor 99,900 78-84	\$ 59.95
Air Filter 99,900 75-84	6.95
Ball Joints - upper or lower (all models exc. 9000)	12.95
Ft. Calipers 99,900 75 on	119.95
Tie Rod Ends 95,96	6.95
Tie Rod Ends 99,900 75 on	7.95
3 Piece Clutch Kit 68 on (4-speed)	89.95
Ft. Brake Rotors 99,900 75-80	19.95
Rear Brake Rotors 99,900 70-80	19.95

Description	Price
Brake Master Cylinder 99,900 8-74 on	119.95
Brake Master Cylinder V-4 71-74	49.95
Wiper Blades 900, Turbo 79-85	3.75
Wiper Blades 95,96	3.75
Ft. Brake Pads	8.95
Rear Brake Pads	7.95
Front End Mask (Bra) 99,900, Turbo	64.50
Timing Chain 99 69-72	10.95
Carb. Repair Kit 99 69-73	12.95

If You Do Not See It, Call Us! We Can Usually Find What You Need

Prices are subject to change without notice. Payments available by Visa, MC, AMEX, Diners Club. C.O.D. orders will be an additional \$1.90. Rhode Island residents add 6% Sales Tax. All Back Orders sent actual shipping. Any item over the UPS limitations will be sent F.O.B. Rhode Island. Prices are good only for the month they are advertised in.
Copyright © 1987 by Special Interest Car Parts



2416 London Road, Unit 900
Duluth, Minnesota 55812

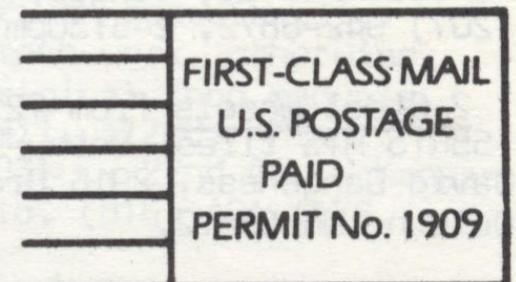

FIRST CLASS

JULY 1987

Exp: 87 12 R