

NINES

THE SAAB CLUB NEWSLETTER

\$1.50
February
1987
no. 156



AKE NORRMAN

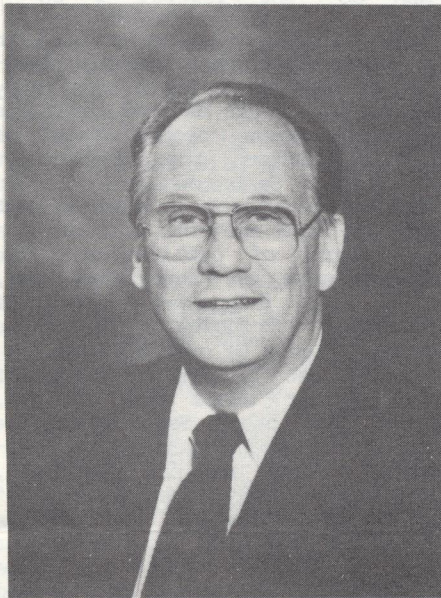

STEN WENNLO



ROLF SANDBERG

SAAB CAR DIVISION GETS NEW GENERAL MANAGER

NYKOPING, Sweden -- The Board of Directors of Saab-Scania AB has named Ake Norrman as the new general manager of the Saab Car Division. Mr. Norrman will take over his duties on April 1, 1987. He succeeds Sten Wennlo, who after 10 years as head of all Saab car activities, worldwide, has expressed his desire to leave this post. Mr. Wennlo will remain as senior vice president of Saab-Scania AB. His duties will mainly be within the product development and marketing areas. He will also retain his posts as Board member in several of Saab-Scania's international subsidiaries, including Saab-Scania of America.

Mr. Norrman, 46, who was also named a senior vice president of Saab-Scania AB, is currently president of Saab-Scania do Brasil, a manufacturing and marketing subsidiary for Scania heavy duty trucks and buses in Sao Paulo, Brazil. From 1964 to 1983 Mr. Norrman worked within the Swedish Volkswagen organization, and from 1979 to '83 was president of Volkswagen i Stockholm, AB, the Volkswagen dealership organization in the Swedish capital.

The Saab-Scania Board of Directors, taking the Saab Car Division's expanding activities into consideration, also appointed Rolf Sandberg, 50, as Deputy General Manager of the Saab Car Division. Mr. Sandberg will maintain his responsibility for Saab product development, design and production. Since 1970, Mr. Sandberg has been manager of the Division's development and production sector and location manager at the main production facilities in Trollhattan.

Mr. Wennlo, 62, joined the Swedish Saab organization in 1960 as public relations manager. He served in a number of sales and marketing positions until 1976, when he was appointed General Manager of the Saab Car Division. He is credited with the great success of the Saab cars during recent years, when world-wide sales have risen from less than 70,000 units in 1980 to 126,000 in 1986.

ANOTHER RECORD SALES YEAR

Saab-Scania AB reported its highest annual sales ever in 1986, with 126,000 units sold worldwide. The 1986 record topped 1985 by 18% and represents increases in all markets.

While sales of the Saab 900 line remained comparable to 1985, sales of the 9000 rose from 7,000 units in 1985 to 32,000 in 1986. This was the first year that the 9000 line was available worldwide.

Export sales accounted for 77% of total sales, or 97,000 units.

The United States continued to be the largest single Saab market. Retail sales in the U.S. reached an all-time high of 47,414 units, up 24% from the previous year. The growth was even larger in Canada, with 1,400 cars sold, an increase of 54%.

In Western Europe, excluding the Nordic countries, sales rose 25%. Significant increases were reported from the four major European markets: France, Italy, the United Kingdom, and West Germany. Austria, Switzerland and Spain also achieved substantial growth.

In the Swedish home market, a total of 29,000 cars were retailed for an increase of nine percent. For the other Nordic countries, the combined sales total was 11,700 units, up five percent.

Considerable sales success was also reported from Australia and

FROM THE BACKSIDE

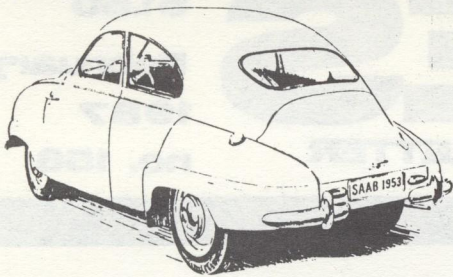

Though this column is toward the front of the magazine, it is about the last thing that gets written each month. That allows me some room to talk about the content of the current issue. This month you'll find new management at SAAB-SCANIA AB, some artwork from members, and a couple of new advertisers. What you won't find is the Saab Transmission Survey. Thor Carlson provided a well prepared, finished report in time for the deadline, but called to say he had gotten quite a few additions after tabulating the results and wanted to add those in. So look for the final survey results in the March issue.

Scheduled for the April and May issues of NINES, in time for summer travel, will be the Saab Club Assistance Network, and an updated Mechanics List with about 30 additional repair shops. If you are willing to be a part of the SCAN, or if you have a repair shop you'd like to recommend, please send the information soon.

Returning for a moment to the subject of artwork, it has been some months since we have heard from Jack Ashcraft. A letter from him this week explains why; on November 8th, Jack got married. Congratulations to Jack and Kathy, and may they have a happy life together. In addition, Jack has restored about half a dozen 96s and Sonetts in the past year, is still doing commercial artwork, is part owner and part time instructor at a commercial art school, and he and his wife have started an advertising agency. They have also moved to Medford, Oregon. He does promise some articles on V4s (when he gets time?) based on things learned while restoring cars.

There is still a lack of articles on early cars, and we may be forced to recycle some old stories on two-strokes and vee-fours. Two phone

calls this week addressed problems of 3-cylinder owners, specifically the lack of parts for rebuilding engines. Mark Rhuede has had some oversized pistons made, and has them for sale in this month's SAAB SWAP. But you can only bore a cylinder so far. Frank Townsend is looking into a different way of dealing with the problem, sleeving the cylinders so you can continue to use "A" pistons, which are still available. It has also become very difficult to locate crankshaft bearings for these engines. Sources for two-stroke parts will always be welcome.

Several good articles arrived in the mail after this month's deadline, so the March issue is already shaping up. I get excited about the innovative ways people have of solving problems, then sharing it with other Saab owners. It is difficult to reject an article, but there are some subjects that stand a slim chance of publication. The "history" of an individual car, unless it describes ways of correcting troubles, has the greatest chance of getting axed.

I also get letters of complaint about repair shops and dealers, asking that other Saab owners be warned about such unscrupulous businesses. These are not published, but are filed away under "Mechanics" for future reference, as problems are often isolated incidents, or minor complaints. There are shops and mechanics who do not have a good reputation, about whom several complaints have been received. That was part of the reasoning behind the ratings in the mechanics list. There are other independent shops which do good work, yet don't have the tools or expertise to perform some major jobs, so do they deserve a top rating? Saab dealers spend many thousand dollars each year for special tools and mechanic training, but there will always be some where the only concern seems to be the Bottom Line, "How much money can we make?". There are also Saab dealers who know that good service means good business. The question is: should we keep the mechanics rating system, or scrap it? If we keep it, how should mechanics be rated?

Finally, the printer misunderstood the directions for the SUBSCRIPTION form on the flyer in the January issue, and I didn't get a chance to review it before it was printed. I will send revised flyers if you request them. Andy Buc is working on a further revision.

Happy Winter driving to you!

Tim Winker, Editor

REGIONAL CLUB NEWS

APPALACHIAN SAAB CLUB -- The Feb. meeting will be held at the home of Joe and Susan Gratz in Morristown, TN. For info: Wendell Francis, Rt. 5, Box 334, Dandridge, TN 37725. (615) 397-2172.

CENTRAL ILLIANA SAAB CLUB -- Starr Tuneup Clinic, Feb. 11th, 7:30pm, limited to 12 participants. The March meeting will be on the 22nd at 2pm, and will feature Saab's new dealer training videos, courtesy of Saab-Scania. Call Margrit Adler, 1507 W. University Ave, Champaign, IL 61821. (217) 356-9244.

MINNESOTA SONETT CLUB will meet Saturday, February 21st, 5pm, at the Classic Motor Company restaurant, on Excelsior Blvd., 1/2 mile east of Hwy. 100 in St. Louis Park. Jeff Schille, (612)457-6891.

NEW ENGLAND SONETT CLUB -- Regular quarterly meeting scheduled for March 7-8. P.O. Box 4362, Manchester, NH 03108.

NORTHERN ILLINOIS SAAB CLUB -- 24 hour Events Hotline, (312) 763-4752.

SAAB CLUB NATIONAL CAPITAL AREA will hold a dinner meeting on Tuesday, March 10th, at the Glen Echo Station restaurant, Glen Echo, MD. Call Toby Turpin, (301)384-6732.

SAAB CLUBS OF GEORGIA -- meets 1st Monday of the month at Steak & Ale at I-285 and Roswell Rd, Sandy Springs. Meetings start at 8pm.

SAAB-SCANIA FLORAL CLOCK CLUB -- meets on the 3rd Tuesday of each month at Tadpoles Lounge, Holiday Inn in Frankfort, KY. Write: Jack Baxter Sr., 322 Murrell Ave, Frankfort, KY 40601.

TULSA SAAB CLUB -- meets the 4th Tuesday of each month at 7:30pm at the Golden Corral, 2145 S Sheridan, Tulsa. Jim Glavas, (918)663-8087.

NEW CLUBS FORMING:

PHOENIX, ARIZONA -- Contact Robert Lanktree, 2328 N. 70th Ave, Phoenix, AZ 85035.

RICHMOND, VIRGINIA -- Contact Bill Harris, (804)270-2185.

UPSTATE, NEW YORK -- The Twin Tier Saab Club is looking to regroup. Contact Alex Barbier, (607)565-2711.

DEADLINE for Club News, the 10th of the month preceding publication.

Saab Club of North America

Editor & Publisher: Tim Winker, 2416 London Rd., Unit 900, Duluth, MN 55812

(218) 525-3253, 9 a.m. - 8 p.m., except Sunday

ASK BOB

Send your questions to:

ASK BOB
c/o NINES
2416 London Road, Unit 900
Duluth, MN 55812-2221

"ASK BOB" is a regular feature of NINES. Submit your questions with as complete information on the problem as possible, also giving the year and model of SAAB. Problems that are of general interest will be answered here. Questions regarding High-Performance tuning and modifications will not be considered for publication in this column.

Neither Bob, NINES, nor the Saab Club will be responsible for repairs undertaken as a result of information in this column. For a proper diagnosis, it is recommended that you have your car serviced by an authorized Saab dealer.

SONETT HEADLINER REPLACEMENT

Is there a way to install a headliner in a '69 Sonett without removing the glass?

D.G., Cornelius, OR

Once owned a Sonett; nice little car. I truthfully can't answer this one for you. Are you going to buy a Saab headliner? Or are you going to use the old one for a pattern? I'd suggest an auto upholstery shop for this one. If you don't want to remove the glass (and apparently you're afraid of the risk) I'd suggest you go to your local auto glass shop and talk to them about removing & replacing the glass.

Bob

95 BRAKES & A SHOCK

Every time I get out of my '72 95, I get a big shock when I touch any metal. What can I do to fix it?

Also, the emergency brake is almost useless, how do I fix it?

W.A.R., Wenatchee, WA

First question... static electricity. Buy some anti-static spray in your grocery store and spray the carpet and seat cushions.

The emergency brake systems on 93s, 96s and 95s were always very good. They work on the rear shoes. The rear brakes on these cars were excellent, but a bit prone to problems. To fix them, you'll find they probably need a thorough refurbishing. I usually find leaking or stuck cylinders, worn out shoes, and frozen adjusters. On a 15 year old car, you may also need emergency brake cables.

Bob

900 ELECTRICAL TROUBLES

I've been having far more than my share of alternator problems on my

'80 900. It has been rebuilt, or replaced with a rebuilt unit several times. Also, the ignition lock relay overheats and sticks. Any suggestions.

L.H., Grissom AFB, IN

As I recall, the '80 had a Motorola alternator. If you're having this much trouble with the original (and rebuilt) I'd suggest you should go to a Bosch unit and regulator.

The original ignition lock relay was replaced with a heavier unit. Ask your dealer about the replacement.

Bob

DASH LIGHT MALFUNCTION

The dash lights on my '83 Turbo don't come on when I turn on the headlights. It usually takes a few minutes or a big bump.

G.B., Normal, IL

Remove the speaker grille and wiggle the bulb holders. Check the bulbs, they're cheap to replace. After that, check the 26-pin connector, that sometimes (rarely) makes a loose connection.

Bob

SCANIA GETS ADDITIONAL TRANSIT BUS ORDERS

Several transit companies have ordered additional Scania CN-112 buses. Iowa City, Iowa, the first U.S. city to offer service with Scania buses in September 1984, has ordered three more buses to add to the 10 CN-112s already in service. Iowa City operates its bus system jointly with Coralville, Iowa.

COAST, the Co-operative Alliance for Seacoast Transportation, Durham,

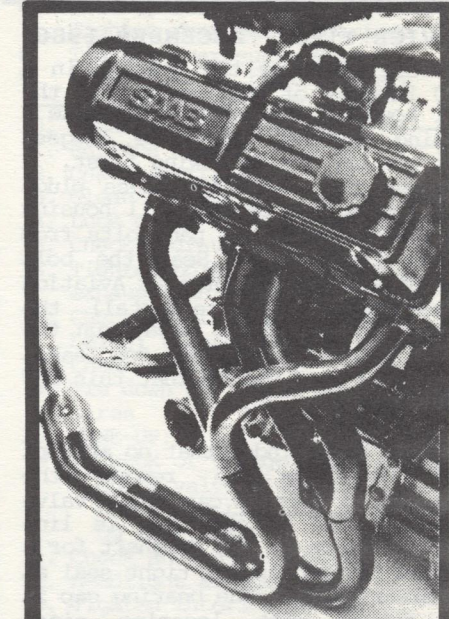

Tuned headers and free-flow exhaust systems for SAABs

STEINWAY IMPORTS
(914) 358-0819

New Hampshire, has also ordered three buses to bring its fleet of Scania's to ten. COAST serves Durham, the University of New Hampshire, and the communities of Rochester and Portsmouth.

The 100th American-built Scania bus was recently delivered to the Metropolitan Transit Commission of Minneapolis-St. Paul, Minnesota. It was part of a 20 bus order by the MITC.

EVOLUTION BY Karin Weiner, Los Angeles, CA

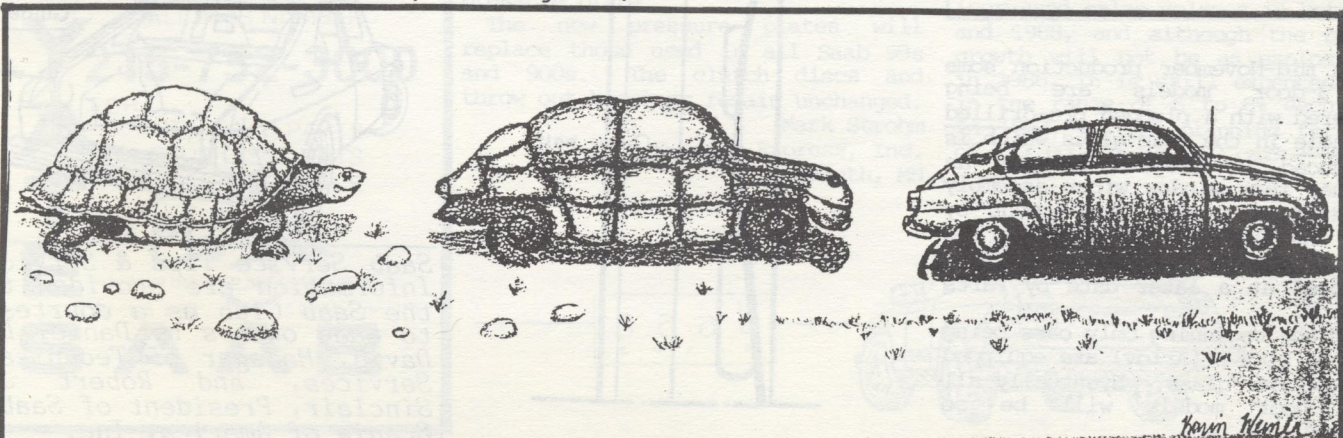

SERVICE SUBJECTS FROM SAAB

SERVICE TIPS: DECEMBER 1986

Before removing the gearbox in a 9000 because of oil leakage in the bell housing area that looks like a leaking flywheel seal, we suggest that you try the following first.

Remove the 2 rubber access plugs from the bottom of the bell housing and remove the 2 oil pan bolts from behind the plugs. Seal the bolt threads with brown Permatex Aviation Form-a-Gasket and re-install the bolts. Clean up the area, run the engine and check the area for leaks. There is a good chance that this may solve your problem.

Please be reminded that no attempt must be made to remove the distributor bearing cap on 16 valve engines. The bearing cap is line bored relative to the camshaft for a precise fit and an oil-tight seal at the distributor. The bearing cap is not fitted with locating pins. However, all the joints are specially sealed to prevent oil leakage.

The bolts are tightened to a specific torque and locked in production. They are not available as a spare part.

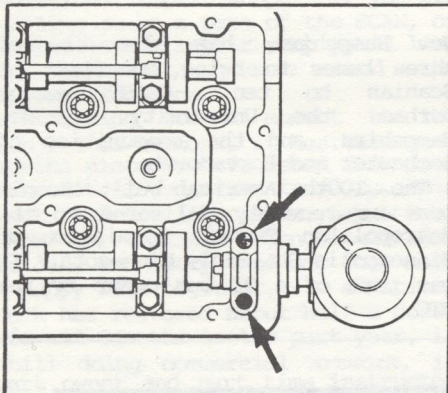

From mid-November production some 900 3-door models are being delivered with a plugged pre-drilled 17mm hole in the rear glass which is introduced in preparation for an optional rear window wiper assembly kit which is under development by Saab. An availability date for the dealer-installed wiper kit will be announced at a later date by Parts Division.

From the beginning only cars being built on line 3 (Arlov) are equipped with the new glass. Eventually all 900 3-door models will be so equipped.

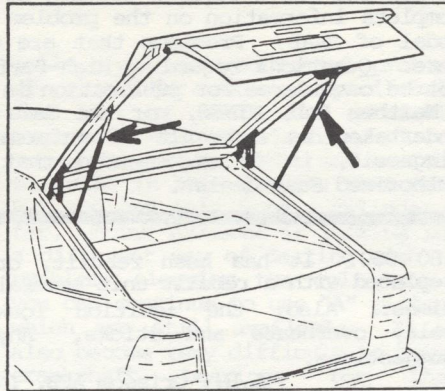

New gas springs are now being installed in production (9000 models only) to reduce the effort that it takes to raise the rear hatch. The new springs have built-in helper springs to help move the hatch during the first few inches of movement. Two different types are being installed, depending on the model variant (with or without rear spoiler).

Earlier 9000 models (built before H1007932) cannot be fitted with the new springs as a service measure due to the increased length of the new springs and the subsequent change made to the hatch. The mounting brackets for the springs have been moved outward by 30mm.

ROTATING WHEEL COVERS

Application: Sabre Wheel Covers
P/N 89-87-604

S.I. 12/86-912: (\$.50)
The Sabre wheel cover is of a two-piece construction. Occasionally the outer portion of the cover may turn in relation to the inner portion, trapping the valve stem. If this happens, the two halves must be re-aligned and secured with Loctite.

This will only occur on covers sold prior to October 1986. The cover that is fitted as standard equipment to the 1987 900 is not affected.

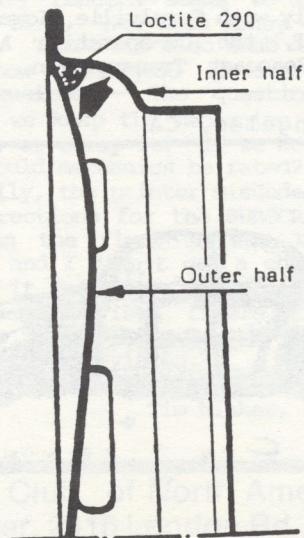

Select four spots to be glued, equally spaced around the edge of the wheel cover. Clean these spots with Loctite Safety Solvent. Apply Loctite 290 at the four areas that have just been cleaned. Allow Loctite 290 to set up for one hour before moving the car.

When installing the wheel covers, index the recess to the tire valve stem. If the label is incorrectly positioned in relation to the recess, remove the label to prevent confusion later on.

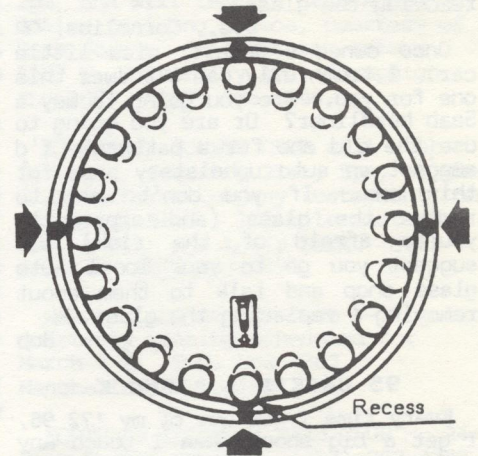

CORRECTING REAR HATCH RATTLE

Application: 85-on 900 3-door
S.I. 12/86-914: Complaints of rear hatch rattle may be corrected by careful adjustment of the rubber stops and the latching mechanism. Follow the instructions below and keep in mind that improper adjustment of the rubber stops can cause distortion of the hatch.

Adjustment Procedure:

1. Check and adjust the fit of the rear hatch seams, if necessary. First, loosen the hinges at the hatch. Disconnect the gas springs. Lower the hatch and

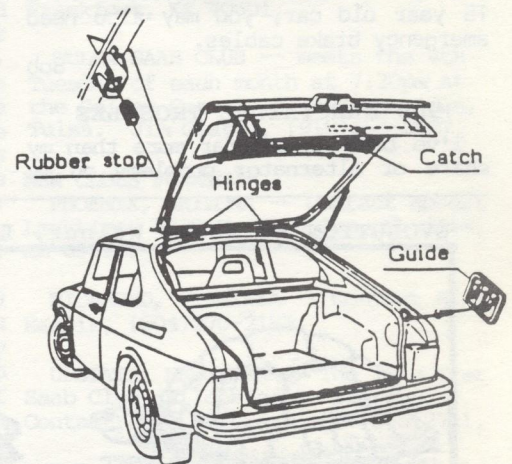

Saab Service Tips & Service Information are provided to the Saab Club as a courtesy to Saab owners by Daniel L. David, Manager of Technical Services, and Robert J. Sinclair, President of Saab-Scania of America, Inc.

SERVICE SUBJECTS continued

- position for the best possible fit. Raise the hatch and tighten the hinges. Re-connect the gas springs.
- Turn in the rubber stops completely.
 - Adjust the door guides to the highest possible position. This ensures maximum contact.
 - Adjust the latch mechanism so that the hatch is held closed as tightly as possible without being difficult to open.
 - Check the condition of the tape (P/N 69-16-944) squares where both stops contact the car body when the hatch is closed. Replace if necessary. Tape squares in good condition contribute greatly to noise reduction.
 - Turn out the rubber stops one turn.

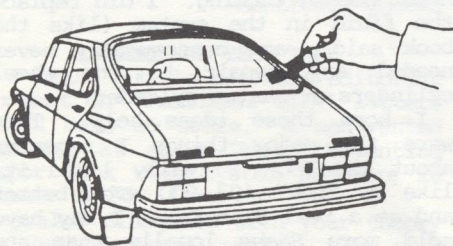

Check this adjustment by placing a sheet of paper between the stop and the car body and closing the hatch. When correctly adjusted, there is just enough contact to trap the paper without forcing the hatch upwards. Turn the rubber stops in or out to make this adjustment and make the adjustment on both sides.

Note: Over-adjusting the rubber stops will distort the hatch.

Be certain that the rattle is not coming from a loose parcel shelf. If necessary, adjust the tension of the speaker shelves upward on the parcel shelf with a plastic mallet.

Remember that anything loose inside the spare tire compartment could sound the same as a hatch rattle.

ANNIVERSARY DATE CHANGED

A phone call from Len Lonnegren as we were going to press indicates that the date has been changed for the SAAB 50th Anniversary Club celebration. The date will now be August 30, 1987. There is some renovation going on at the Trollhattan factory, and this will allow more time for completion. Saab will also get a chance to display their 1988 models.

This will be an advantage as airline fares drop after mid-August. It also gives more time between the Tulsa National Convention and the Swedish event.

Paul Florance reports that he has received about 20 letters from members interested in the flight to Europe for the 50th Anniversary. He is working with a travel agency in Southern California to schedule a charter for 50 people. The air fare will be about \$550 round trip, from New York to Copenhagen. Paul says it would cost several hundred more to fly directly to Stockholm, and that taking the ferry and train from Copenhagen will help to keep travel expenses down.

CHANGE IN CLUTCH PLATES

Borg & Beck, supplier of OE clutch parts to many European auto manufacturers including Saab, has changed the design of their clutch pressure plates within the past year. The same basic design is used in Borg & Beck clutches for Saab, British Leyland, Volvo and other companies. The difference is in the outer housing of the cover and in the diaphragm. The center of the diaphragm (fingers) now has a visible rise, as opposed to the old design which appears flat.

The "cheater" method of using a piece of fan belt to keep the fingers depressed will no longer work due to the new design. You now need to use a piece of 3mm wire between the fingers and the cover.

Many companies are still working off of "old stock", and will continue to offer the old style plates until supplies are exhausted. The new plates are apparently just an update, as there has not been a problem with the previous style of pressure plate.

The new pressure plates will replace those used in all Saab 99s and 900s. The clutch discs and throw out bearings remain unchanged.

Mark Strohm
Swedish Express, Inc.
Duluth, MN

SERVICE CHECKLIST

Nicholas Pellegrino of Foreign Motor Repair in Ithaca, NY, uses this checklist for major service at 15, and 30,000 miles:

- Put car in air; remove wheels
- Check ball joints
- Check tie rod ends
- Check front wheel bearings
- Check front brakes for dragging
- Free up rear brake
- Tighten rear wheel bearings
- Tighten rear suspension
- Free up front brakes; check emergency brake function
- Tighten front suspension
- Replace fluids
- Check antifreeze
- Clean battery
- Lube car
- Check hydraulic fluids
- Tighten bolts on intake and exhaust manifolds
- Check air filter, hoses & belts; tighten hose clamps
- Check ignition wire resistance
- Tie down any loose or dangling wires
- TUNE-UP:

Check or change spark plugs
Check valve clearance
Check distrib. cap & rotor
Do fine tune

- Check and adjust toe-in
- Headlight alignment
- Tighten interior screws
- Lube interior
- Check tire pressure
- Armorall dash & kiss it bye-bye

SALES RECORD - Continued

Japan, where sales increased by 27% and 60% respectively.

Deliveries under Saab's IDS plan, a program offering tax and duty-free sales to tourists, diplomats and armed forces personnel, continued to grow in 1986 totalling 5,500 cars, up 11 percent over 1985.

Sten Wennlo, chief executive of the Saab Car Division, commenting on the sales growth in 1986, said: "Even though we increased production heavily during the year, we were still unable to satisfy the demand. Our plans to increase production capacity over the coming years therefore remain firm."

Projecting 1987 sales expectations Wennlo added, "We look forward to increased sales volumes in both 1987 and 1988, and although the rate of growth will not be as explosive as in 1986, it is still expected to be in the range of 5 to 8% each year. In 1987, we are planning for sales of 133,000 to 135,000 cars."

CALL THIS NUMBER
Y 215-752-3000

FOR:
— OEM SAAB PARTS
— CLUB DISCOUNTS
— FAST UPS SERVICE

ATE
Bob Yates
IMPORT CAR SPECIALISTS
Rt. 1 & I-95 Langhorne, PA

SAAB

saab
turbo

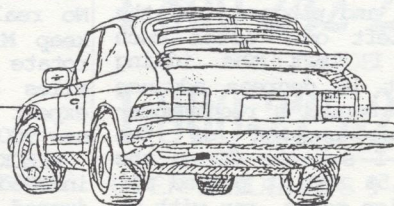

Shant

TECHNICAL TALK

Technical articles written by subscribers may recommend procedures or parts not approved by Saab-Scania of America, Inc. The Saab Club of North America cannot stand behind the correctness of information in these articles, but offers them based solely on the experiences of the writers.

COOLER THERMOSTAT CURES

HOT START PROBLEM

99 owners who have hot start problems can significantly improve this condition by installing a Volvo 180° F thermostat. This is in addition to all other mods to cure the problem. The Saab 190° F thermostat is too hot for summer use. Since I've changed to the 180° unit, I have had very little problem with hot starts. The 190° thermostat is fine for winter use.

John Smith
Montreal, Quebec

BIOGRAPHY OF A 99

I thought I would share some experiences of my former Saab, a '73 99EMS. Be sure that we miss her (my wife named her Sadie), and her new owner is just as happy. My '83 900 rolls on, and since approaching 56k miles might be the subject of a future letter.

CYLINDER HEAD: Yes, I had my turn with that chronic problem; my result was a happy one, though. The symptom was the Saab ran rough for 30 seconds or so on a cold start, it began using antifreeze, and the exhaust water tasted sweet. The problem occurred at 105k miles. I pulled the head and found a burned through gasket between #2 and #3 cylinders. I had the head pressure tested. (I had to insist; the local dealer was against it as unnecessary, he couldn't do it and felt it was a waste of money. I found that mine was just the gasket. The head material can burn through between the combustion chamber and the water jacket at the same location.) A simple valve and valve guide job, milling the head slightly for insurance, \$150 total for the head work, and I was in business again. The rebuilder who did the work was Eriksson Industries, LTD (Nat Wentworth, 42 River St., Old Saybrook, CT 06475. (203)388-4418.) who, at the time did all kinds of Saab work, even raced them.

DISTRIBUTOR ADVANCE/RETARD & IGNITION TIMING: I found that the car ran best with the vacuum retard hose taken off and plugged, and the vacuum line left on. After much experimenting I left the idling advance set at 16 degrees advance instead of the manual's recommendation. On reconnection of the advance hose, I set the CO on the computer to 2.5% and it passed all required emission tests, ran with no hesitation, drivability improved,

and the mileage improved from 22 to 26mpg. Even with this much excess advance it never pinged, and I made it a point to buy the cheapest gas I could find at all times.

THERMOSTAT: Early on I changed the thermostat from 192°F to 180°F. I had a philosophical problem with hot engines, but found that in conjunction with the hefty advance the engine ran much cooler and the heater was more than adequate in most Connecticut winters. The cooler running may have helped extend the life of the head.

TRANSMISSION GEARS: In the 120k miles I owned the 99 the transmission had no work, but it was ready for some. The splines in the transfer case up front were worn, gears slapping the block, and the pinion gear inside was about to fall off. Eriksson would have respined the transfer case gears for a nominal amount (about \$100 vs. the dealer's \$700 estimate for the part and work), but I was stuck with the pinion gear myself. I religiously changed the oil in the transmission, always with 75EP GL5, and found that 80W90 was too thick for smooth shifting and drained that experimental oil in the dump!

CLUTCH: I was easy on it, but my wife learned to drive on "Sadie". Still, 120k and it was holding well, but I expect it was overdue. No noise from the throwout bearing, either. The clutch master cylinder failed about once a year without fail, even when using Girling-approved fluids, until I found the problem to be the fluid attacking the return spring inside the unit (Can't claim any great wisdom here - it broke in two and was laying on the bottom of the housing). A makeshift spring from the hardware store and I was in business again. I honed the master and slave cylinders many times, but never replaced either, just the seals.

TIRES: I always had trouble there. The original Semperits wore to 40k, but slipped belts (just like the 900s do) and were trashed. The replacement Vredesteins were the worst tires I ever owned, and they caused a wreck in the snow one time. No real recommendation here except keep Michelins or Pirellis on and rotate front to rear every 7500 miles like you're told to do. I expect 60k from my Pirellis on the new 900.

WRECKS: I mentioned the tire-induced wreck. A Connecticut rock jumped in front of my LF wheel when turning hard left and bent it under.

Turned out that the A-arm was the weak link, and when replaced the wheels were not even out of alignment! No frame alignment was necessary. Kudos to Saab for a great design. The local repair shop told me 99s require more tension to straighten frames than any large truck they ever worked on. The steering rack was also bent in this one, but the dealer (Nelke Saab in Old Saybrook) bent it straight with no problems.

BRAKES: The front pads wore out about 12k miles all the time. They were a 30-minute fix, and the rotors never needed turning. I did replace the fluid in the system (like the book said), and consequently never needed any repair to the wheel cylinders or master cylinder.

I hope these ideas help. They were the major things I remember about the 99. I really liked it, like my "new" '83 900 even better and am a real Saab fan. I may have sold more Saabs locally than any salesman who only earns money from them.

Ken Williams
Old Saybrook, CT

STARTING MOTOR NOISE

My '77 99GLE was plagued off and on with a groaning sound from the engine which seemed to occur more frequently in the winter and in damp weather. The noise would last 2-3 seconds immediately after the engine was started. The starter pinion gear was not jamming on the flywheel ring gear, but it seemed to lack lubrication inside. There was a lot of salt and crud on the starter motor housing, so I assumed some of it was also inside. It appeared to be quite a job to remove the unit, so I took the following short cut:

1. Remove the plastic clutch housing cover.

2. There is a small opening in the drive housing for the pinion gear. If you are patient and careful, you can put a little silicone grease on the motor shaft, which the pinion rides on. Use a piece of bent wire with a small cloth pad on the end. Don't put on too much or you will gum up the electrics, or worse, the clutch facing. Also grease the pinion lever ring.

3. Put a couple of drops of oil inside the housing on the front end shaft bushing.

4. The starter motor shaft's front end bushing extends through the drive housing where salt and moisture can corrode it from the outside. Clean this area and oil

OVERSEAS CLUBS

We would like to inform you that the Norwegian Two-Stroke Club has changed its address, and that all correspondence should henceforth be sent to:

Gammalsaabens Venner
P.O. Box 70 - Vestli
N - 0911 Oslo 9
NORWAY

A Jubilee Meet, to celebrate the Club's tenth anniversary, will be held in Oslo June 6-8, 1987. Although the programme has not yet been finalised, any member of the Saab Club wishing to take part would of course be very welcome indeed, and should get in touch with us at the above address.

Tom Eidesen
President

Some tidbits of information from Club Sonett Sweden. The club's new address is:

Club Sonett Sweden
c/o Per Alvestig
Karlstorpsvagen 61
S-46153 Trollhattan
SWEDEN

Their last newsletter (4/86) reveals that they have found a good supply of glass for the Sonetts, both the Sonett II and V4, and the III. What's more interesting is that the manufacturer still has the forms for the glass, including the rear window for the Sonett II & V4.

Bjorn S. Collin
Surrey, B.C. CANADA

RENT-A-SAAB IN CALIF.

For those who get to Los Angeles or San Francisco for one reason or another, you may be interested in knowing about Showcase Rental Cars. They rent a gamut of car models including Saab Turbos. I've rented an '85 900 Turbo and and '86 9000 Turbo on two trips over the past year. On the 9000 trip, my wife and I drove to Yosemite from San Francisco. A great destination and test drive route! The number for Showcase (outside of California) is 800-421-6808.

Stephen Carrellas
Berkeley Heights, NJ

ANOTHER EUROPEAN DELIVERY EXPERIENCE

The article on European Delivery was interesting. We had some of the same experiences, but we intended from the start to avoid staying in larger cities. There is no reason to do so as adequate motels can be found in smaller towns. Gas is high, but not horrendous, since you don't use much. I thought the ferries were cheap.

We did have one major problem, but it was back here in the States. While unloading the car from the ship, someone was hot-rodding and sideswiped a pillar, damaging most of the right side. I never knew how bad because they fixed it before I saw it.

Jim Winker
Sioux Falls, SD

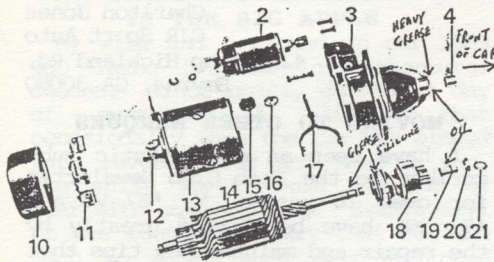

STARTER DISASSEMBLED

it. Put a coating of heavy grease over the end of the opening to protect it from further corrosion.

5. While performing the above steps, it is a good idea to crank the starter motor a little after each lubrication. Don't spin the motor fast or the lube will splash off and cause other problems.

John Smith
Montreal, Quebec

COMMENTS ON TECH TALK

I would like to see more editorial comment on "Technical Talk" letters which make no sense. A non-vented gas cap at about 2psig preventing vapor lock when system pressure is closer to 70? Come on!

I also disagreed with your theory on how methanol works. It also brings water into solution. If it floated water to the top as you say, one would eventually end up with a tank of water since the fuel pump siphons from the bottom of the tank. Isopropanol is safer for the fuel system and I would like to know of a gas line antifreeze which uses it. "Christy" used to but is now based on methanol, at least in my area.

RE Kenneth Kemons letter - Saab head bolts should not be re-torqued. Head bolts should never be re-used because they fatigue, especially the elastic type Saab uses (torque to 60 plus 1/4 turn).

I don't like to see letters critical of anything after one bad experience (e.g. CV boots in January issue). I doubt there's anything "cheaper" about current drive line boots.

I built the Pulse Relation Meter mentioned in the Aug/Sept issue and it's perfect. Thanks.

Douglas Beards
Hartsdale, NY

ED NOTE: My words on methanol came from a methanol/isopropyl comparison demonstration given by a salesman about eight years ago when I sold import auto parts and chemicals. Logic tells me that alcohol and water mix, and that a methanol based gas line antifreeze should pass the solution through the system. Several companies market isopropyl based fuel system antifreeze in this area, including "px Super 99" by Fox Chemical Co., 137 S. Robert St., St. Paul, MN 55107.

SAAB SNOWTIRE SALE!



ORDER NOW

THROUGH MUD, SNOW, SLEET AND RAIN GOES A WINTER TIRE WITH THE NAME ...

GISLAVED

A HYDROPHYLIC COMPOUND TIRE WITH AN AGGRESSIVE TREAD DESIGN HUNGRY FOR ALL WINTER CAN DISH OUT. **MOUNTED AND BALANCED ON A SAAB WHEEL** FOR EASY ON AND EASY OFF APPLICATION.

• FITS 900'S • HUBCAPS AVAILABLE • UPS SERVICE AVAILABLE



QUANTITIES LIMITED

94⁰⁰ ea

JACK SAFRO
Tosa Imports
THE WAY YOU EXPECT IT!

6102 W. North Avenue
Wauwatosa, Wisconsin 53213

VISA AMERICAN EXPRESS MASTERCARD

DIRECT LINE TO PARTS

WISCONSIN

1-800-242-2003

NATIONWIDE

1-800-225-2528

OPEN SATURDAYS 9 - 1 P.M.

ROADSPORT motoring accessories

900 DEAD PEDAL
Protects carpet
next to clutch **19.50**

TB900 THROTTLE BODY
99 & 900 & Turbo
Direct mounting
Fits 75-83 **114.95**

ROADSPORT
P.O. Box 566671
Atlanta, GA 30356

BRIGHTEN YOUR NIGHTS

As the new year rolls in, most of us look forward to the warm months ahead. This isn't a special time of the automotive year, except for the endurance racer. The January/February junction hosts the Daytona 24-hour, our longest enduro for international class racers. March brings us to the Sebring 12-hour, probably the U.S.'s second most famous international endurance run. Both of these events require man and machine to perform when the sun doesn't. So my mind quickly turns to automotive lighting (as it has for the past 14 years).

Automotive lighting is most likely the subject area most taken for granted by the largest majority of otherwise serious enthusiasts. Ask almost anyone, "How are your headlights?" He'll say "Fine." That ain't necessarily so.

Those who have driven in Europe, those who have driven a European version before it was "converted" know of what I speak. All lights are not created equally.

You say, "But new cars now have halogen headlights!" But they aren't the same. The real enthusiasts know; the Europeans still have better. The Porsche 928 has Sylvania halogens. The Euro version doesn't. The Saab 9000 (and '87 900) have Hella aerodynamic headlights with Sylvania 9004 halogen bulbs; the Euro model has CIBIEs with H-4 bulbs. The VW Golf and Jetta, the 911 and 944... same story; different lights. What's the difference and why did we get screwed?

Europeans use the European pattern

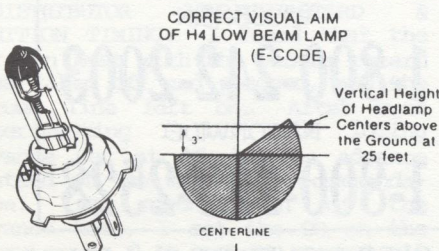

(or E-code) lamps powered by the proven H-4 bulb with an axial filament. The headlight pattern places light on the road, on road signs to the right, but not in the eyes of on-coming traffic to the left. The upper "cutoff" of the beam is like a good fog light lighting up the road ahead and not the particulate matter in between. And the proven H-4 bulb outlasts the Sylvania 9004, yet costs far less. Which brings me to the second answer (to the why?)

Our government (spelled NHTSA) is looking out for you and particularly for the American lighting industry. The U.S. industry made a mistake back in 1957; instead of releasing the new H-4 technology when the Europeans did, we got the quad light system with its smaller sealed beam for worse performance. Now the American companies find competition from an established European industry. At a time when new tooling is prohibitively expensive, the American companies decided to rule out the foreign competition with a law that defines the design, not the performance. The H-4 is technically illegal for cars. It's okay for motorcycles; I guess that wasn't a big enough market to worry about. Fortunately, we have no Federal police force, and the states have left the concerns to the Feds. U.S. manufacturers buy American, as they wish you would, and imports must come under the watchful eyes of U.S. Customs (the closest we have to a Federal Police Force). After that, you and your car are on your own.

If you'd like some direction, I sincerely recommend the racer's choice (over 90% of the starting grid for the past 14 years at both Daytona and Sebring), Cibie and Marchal [both made by Valeo]. If you see any other lights at these prestigious races, they are either on a back marker, or were supplied free by another manufacturer. I sell all the good brands; Cibie, Marchal, Hella, Carello, Auteroche, etc., but I use Marchal and Cibie on my own car, like the Porsche factory uses on its race cars, because th

work the best. And I can demonstrate the difference!

Charlton Jones
CJR Sport Auto
4292 Camp Highland Rd.
Smyrna, GA 30080

MOVING TO OTHER MARQUES

I have been an enthusiastic subscriber to the Saab Club Newsletter for over 10 years. My '67 V4 and '73 99L have benefitted greatly by the repair and maintenance tips that the many members had published.

I recently had to make a decision whether to spend much money for repairing both cars or buying new. We all have to make this decision sooner or later. After visiting several dealers, I made the decision away from Saab and to Toyota, not by choice but by economics. Had Saab offered a car in the Tercel price range, I would have purchased same. However, their philosophy now appears to compete with BMW, Mercedes, and Volvo. It's too bad that Saab has not offered an updated 96 for the U.S. market. With that, I bid you fond Adieu.

Raymond Stepura
Bethlehem, PA

I used to own 3 Saabs; a '70 Sonett III no. 15, a '74 Sonett, and a '77 99EMS. I still have my Sonetts, but I sold my 99 when I bought my '86 VW GTI.

I would have liked to have been able to buy a new Saab, but an EMS-like Saab is just too expensive. Like the EMS, the GTI has these features: SOHC Bosch fuel-injected four, all-disc brakes, sport suspension with alloys, FWD, and non-Japanese engineering and manufacture. (They won the optical and electronics wars, but I don't want them to win the car war yet.)

This VW is my first new car, so I was surprised to discover how sloppy American assembly still is. Such things as faulty switches, hanging and unfinished upholstery, water leaks, mis-aligned bonnet and steering wheel, etc. But it is a fun car.

Ron Canaday
Kansas City, KS

Swedish

PVR

Tradition

Viking Parts & Repair

Saab Specialist

612/389-3776



BRAKE SPECIAL

Brake Pads (99/900 ft. or rear) \$11.99 set
Front Caliper **New** left or right 75 & up.
\$129.95 Ea.

Brake Rotor **New** ft. or rear \$22.99 Ea.
Oil Pressure Switch (up to 80) \$2.99
Oil Pressure Switch (81 and up) \$4.99

PRICES GOOD THRU FEBRUARY 28, 1987

VIKING PARTS & REPAIR

ROUTE 4 BOX 247A
PRINCETON, MINNESOTA 55371

TRANSMISSION ABUSE IN THE BIG APPLE

My wife and I picked up our 1983 900 Turbo 5-speed in Gothenburg, Sweden. Since nearly our first day of ownership I noticed that occasionally when the car was placed into reverse gear and then driven, the shift lever would pop out of gear with no prompting. Eventually, it was found necessary that for the Saab to avoid such self-inflicted wounds to the reverse gear teeth I would have to physically hold the shift knob in reverse while the car was in motion.

The second significant event in the life of my car (an on-going one) occurred after the car was shipped to the states from Amsterdam (courtesy of IDS). The car's permanent address was to be mid-town Manhattan, a harsh environment indeed for most cars. There is no street parking 6 days per week from 7am to 7pm in my neighborhood. The use of a public parking garage is a necessity for anyone who lives in mid-town and owns a car.

Often times this means that the car is left in the not-so-loving care of garage attendants (who must own stock in the local body shop). Every day I bless the genius who thought of installing on Saabs their prominent 5mph bumpers.

However, prominent bumpers alone are not sufficient to protect the Saab's transmission from itself, in particular I'm referring to the need to leave the transmission in reverse in order to remove the ignition key. Garage attendants in New York City are notorious for their speed -- in your car. When they park your car they often back it up 'til it hits the car behind it, then they turn the engine off in whatever gear it was left in (usually reverse except for automatics). Then when the space in front of your parked Saab is to be filled, the next car is backed into yours (sort of a perverse biblical equivalent of your car experiencing from others what it has done to the car behind it) with the result that the reverse gear teeth eventually get chipped down to the nubs. All of this punishment to the transmission is further aggravated if the car behind yours has to be moved (and it often does). An automotive version of musical chairs takes place, sometimes several times a day, 365 days per year.

By the time 36,000 miles had bumped and banged around, the reverse gear teeth were totally worn away, necessitating a complete transmission tear-down. The other gears were OK though the pinion gear also needed to be replaced. I needed a vacation. Figuring that since my mind was so numb from the trauma of having to permanently shell out over \$1500 for repairs, I didn't think my wife and I would notice the sub-teen temperatures

that went with a week of skiing while the car was being repaired. After retrieving my Saab I changed parking garages where the attendants let me park my own car and take the key with me, except when my car was blocking someone else's means of weekend escape. It rarely did.

I asked the mechanics at Setauket Foreign Motors who repaired the transmission to return the hapless gear to me. It now makes a wonderful paperweight. It also serves as a reminder that sometimes owning a Saab in NYC is like having to breathe -- you have to do it but wish that the air was from somewhere else. I also had them remove the reverse gear/ignition interlock. This now means that whenever I park my car I can remove the ignition key while the transmission is safely residing in neutral.

I cannot overemphasize the value this action has had in reducing my anxiety when I have to parallel park on city streets. Usually it is not the car that has managed to park in front of or behind me that I worry about (maybe I should) but rather the clapped-out '69 Buick Electra driven by someone with either too little or too much experience behind the wheel who insists that his car will fit into the empty space that could only contain a VW. After several failed attempts, frequently evidenced by cracked tail-lights, directional signals, grilles, etc. (invariably done to your car but not to his) the idiot finally gets the idea that square pegs don't fit into round holes. I have literally seen some drivers, out of desperation, use their cars to shove parked cars forward or backward to make room for theirs. There is simply no limit to what extremes people will go to avoid getting ticketed and possibly towed!

To date my Saab has about 60,000 elapsed miles, the transmission goes into reverse and stays there without further prompting, and the Christmas gratuities to the garage attendants are gladly given because they haven't parked my car.

There is, however, one disturbing quirk that occurs with about 5% of any attempts to shift into reverse. Sometimes while very carefully moving the shift lever into reverse there is the distinct clatter of the reverse gear teeth slipping past each other before they engage. Obviously this is something to check out before the 1 year warranty on parts and labor for the rebuilt transmission expires.

On a different subject, my response to the Kent inquiry in the November NINES concerning air bladders for the rear springs is that they are probably worth the investment. I installed them on my car because I often carry heavy loads in the trunk. Normally this wasn't a big concern for me except that I had also installed European flush headlights with 90/100 watt

SWEDISH ADVANCED AUTO BAY INDEPENDENT SAAB REPAIR PARTS & SERVICE

N.I.A.S.E. CERTIFIED

FACTORY TRAINED

LEWIS NORRIS
Master Technician

15616 INGLEWOOD AVE.
LAWDALE, CA 90260

1/2 Block So. 405 Fwy.
(213) 536-0161

bulbs and King Kong sized fog-lights up front. Since I drove with my headlights on all the time (the fogs were on only at night) any additional weight over and in back of the rear axle tended to redirect the headlights so that they flash-blinded the squirrels in the trees, to say nothing of what it must have done to the retinas of on-coming drivers. The police in New Jersey have made their opinions known to me on this subject several times prior to my installing these devices. So if the air-bladders have done nothing else they have kept the police at bay and the on-coming night-time drivers* from angrily trying to blind me in return.

Under heavy loads inflation pressure is kept at the recommended 28-30 psi and when the trunk is empty I keep about 12 psi back there, otherwise the ride becomes too harsh. I also keep a portable air compressor in the car for obvious reasons.

Regarding Saab's suggestion in the installation instructions that the inflation valve be located in the trunk, I prefer to keep mine in the rear passenger compartment below the hinge for the bench seat cushion where it is readily accessible.

I've also installed Saab's anti-roll bar kit and haven't regretted it. The most notable change in the handling occurred during the rain. I tend to drive my car with a good deal of alacrity most of the time anyway, but prior to the anti-roll bar installation I found that front traction under power in curves in the rain left me feeling like the old man who discovered that while his mind was willing his equipment was not. Talk about discovering the fountain of youth! So much for right brain pleasures (to borrow from the analogy of certain Saab advertisements). As far as the left side of the brain is concerned anything that will improve the traction of the car in the rain without having to change tires or anything else can only add to the margin of safety of an otherwise stable and forgiving car. I suppose the above observation was shared (in part) by Saab in Sweden and has something to do with Saab's decision to install this device as standard equipment on 1987 Turbos and 900S's here.

Gene Zagorsky
New York, NY

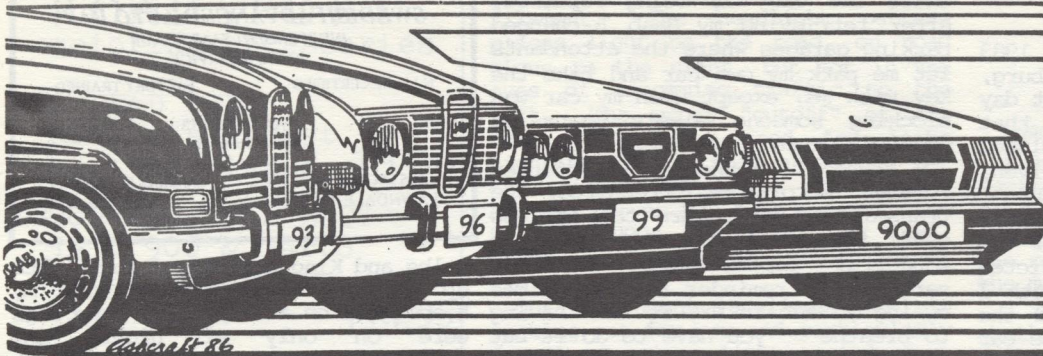

SAAB SWAP

CLASSIFIED ADS

CLASSIFIED AD RATES

Ads offering parts or Saabs for sale or wanted are available to members and non-members. Ads are limited to 25 words, plus name, address, and phone number. Ad copy will be abbreviated and excess words deleted where possible. Enclose sufficient funds with your ad, we will **not** bill. No ads will be taken by phone. The Classified ad rate is based on the total dollar amount listed in the ad.

Under \$200	Free
\$201 to \$900	\$2.00
\$901 to \$2000	\$5.00
Over \$2001	\$10.00
Ads without a price listed ...	\$10.00

DEADLINE: Second Friday of each month for the following month's issue, i.e. the second Friday in January for the February issue.

COMMERCIAL ADS: Contact Editor for rates and info. Deadline, First Friday of each month for the following month's issue.

Sonetts For Sale

74 Sonett III, low miles, yellow, Klebers, AM/FM. Great condition. A real head turner. \$4350. Robin Rodabaugh, 3716 Dover Dr, Mountain Brook, AL 35223. (205)967-5015(h), 868-3183(w).

73 Sonett, 70k mi, no rust, Guards red, Konis, 96 springs & sway bars, new interior, custom seats, stereo, MSS exh, carb & manifold. \$6500 obo. Erik Pottala, 3634 Buckeystown Pike, Buckeystown, MD 21717. (301)831-8338(h), 496-2959(w).

73 Sonett, 64k mi, serial #0010, vy gd cond, no rust. \$3500. Paul Glavas, 5615 S 82 E Ave, Tulsa, OK 74145. (918)250-2150.

73 Sonett, 83k mi, maroon, AC, AM/FM. Good F/G, interior, eng & trans. Some rust. MSS exh, new clutch, rblt hydraulics, spare eng. \$900 obo. **SOLD** John White, 5028 Castlemoor Dr, Columbia, MD 21044. (301)486-7525(h), 962-7600(w).

93s, 95s, & 96s For Sale

71 96, white, exc body, no rust, less than 1000 mi on rblt eng/trans. \$2500. Richard Lawrence, 411 South Cherry St, Richmond, VA 23220. (804)225-7117 mornings.

71 96, Weber 28/36 2bbl, Konis, Sonett wheels, Sonett steering, MSS clutch & exh, no rust. \$2200 obo. Mike Tucker, 2324 Davis Dr, Matthews, NC 28105. (704)846-4098.

71 96, runs good, clutch slips, some rust. Good winter car or parts car. \$400 obo. Rob LaMountain, East Thetford, VT. (802)785-2931.

68 95, 63k mi, gd eng, poor clutch. Fair body, poor floor pan. Car in central PA. Will trade for functional vehicle. Fred Walter, Berlin, NJ. (609)768-1699 eve.

67 96 Deluxe, blue, 119k mi, trans rblt 10k ago. Topside great, floor pan rusted. \$150. Factory manual for above, \$15. Factory manual w/plastic cover for 73 99, \$20. Ray Stepura, 3606 Hecktown Rd, Bethlehem, PA 18017. (215)691-1256.

63 96, restorable or for parts. Complete, minimal rust, interior fair. Car in Ada, OH. \$200 obo. Steven Hindall, (614)431-0138.

61 96, solid, no rust, good compression, lots of extras, \$800. 3 spd trans, \$100 +shpg. Stuart Gaetjens, 511 W. Washington, Champaign, IL 61820. (217)351-4976.

2 Stroke & V-4 Parts For Sale

72 Sonett engine, Gd cond, \$200. Many other Sonett & 96 parts. Nick Hayden, 3385 W. 86th St, Cleveland, OH 44102. (216)281-9823.

Rblt V4 engine, sport cam, ported heads, balanced, over \$2000 invested, make offer. Mike Tucker, 2324 Davis Dr, Matthews, NC 28105. (704)846-4098.

V4 close ratio gearbox, Special II gear set, 4.57 crown/pinion, special brng pkg, cone clutch type ltd-slip. Used only on weekends. \$1500. Jack Lawrence, 1400 E. Second St, Jamestown, NY 14701. (716)665-4200.

Turbo for V4, incl intake & exh manifolds, ign retard, wastegate, rblt 2bbl carb & Rajay turbo. Could fit Sonett with a few mods. \$675. Steve Bottorff, PO Box 39550, Solon, OH 44139. (216)248-0400 days, 752-0430 evenings.

New Oversize 2-stroke pistons made by Jahns, Monte Carlo design, incl new wrist pins, rings & lock rings. 1.5mm over standard. \$180/set +shpg. Mark Rheude, 781 E. Swanee Ln, Covina, CA 91723. (818) 332-0046.

NEW PARTS. A jackpot of hard to find 93/95/96 parts. \$125 takes all. John Fog, 9713 N. 56th Dr, Glendale, AZ 85302. (602)937-9128.

Rear clip from 71 Sonett, F/G only, yellow, vy gd cond, \$275. MSS 43mm 1bbl carb & manifold, \$100. Trailer hitch for 96, \$30. D.M. Rasmussen, 104 Pinecrest, Auburn, CA 95603. (916)823-7460.

Rblt V4 starters/alternators, \$75. S-III rear window, \$75 (can't ship). Sonett-III rear F/G clip, \$400. Pair of black vinyl S-V4 seats, \$100. 6" wide steel wheels, \$50 ea. Mike Tucker, 2324 Davis Dr, Matthews, NC 28105. (704)846-4098.

95 rear hatch & complete tail lens set. \$25 obo +shpg. Bruce Alexander, 4719 Pitt, Duluth, MN 55804. (218)525-2884, 12-3pm & wknds.

Solex 32PDSIT carb, \$25. Weber 34-ICH w/mounting kit, \$70. Blue 1500cc eng (runs), \$100. 4 beauty ring hubcaps, \$20. AC w/instr, \$120. Keith Bridges, 4305 D Van Nuys Blvd, Sherman Oaks, CA 91403. (818)784-0758

Weber 34-ICH carb, used/rblt with linkage, \$75. 95 trailer hitch, \$45. 75-79 Subaru grill/sump guard, \$80. Eric Killinger, PO Box 283, Boulder, CO 80306. (303)447-9298.

So Neat Things for your Sonett. Send SASE to ReSearch, Rt 6 Box 84, Alexandria, MN 56308.

99s & 900s For Sale

83 900 Turbo, hatchback, 65k mi, \$9500 obo. V.A. Alger, 3726 Lakeview Rd, Memphis, TN 38116. (901)398-3612.

78 99 Turbo, maroon, new turbo & clutch. Sharp, no rust. Sunroof, louvers, fogs, much more. \$4750. Marc Kaufman, Atlanta, GA. (404)256-4436.

78 99 Turbo, 96k mi, stereo, sunroof, extra rims. New turbo, catalyst, exhaust... Every receipt since new. \$3700. Fred Hughes, Seattle, WA. (206)283-1290.

99 and 900 Parts For Sale

Used 99 engines & transmissions, glass & body pieces, many good used parts. Neil Lindemann, PO Box 3153, Ann Arbor, MI 48104. (313)994-5236.

900 parts from several cars. 4spd & 5spd trans, body parts, elect & FI, "B" eng head, steel & alloy wheels. Soon parting out 85 SPG. Dennis Sweeney, 207 E. Church St., Ligonier, PA 15658. (412)238-4556.

900 thru 16 valve dismantled cars. 16v eng compl w/FI & turbo, wiring, intercooler, brain, etc. Drivetrains for 900 & Turbos, interiors, heads, manifolds, radiators, pur steering, gauges, suspension, etc. Michael Caro, 278 Boston Post Rd, Orange, CT 06477. (203)795-0776.

Parting out 79 900T 3dr, 56k mi, wrecked. Eng w/turbo & rblt trans, \$800. Interior & dash, rear glass & windshield, wiring, axles & susp, all in gd cond. Hood & doors gone. David Adams, 17107 Invermere Rd, Cleveland, OH 44128. (216)751-8109.

Parts from 74 99LE 4dr, doors, \$10ea. Windshield, \$30. Rear window, \$15. Body shell, \$100. Much more. Mitch Lemmo, 353 Roxbury Rd, Stamford, CT 06902. (203)322-7457.

From 74 99LE, 2.0 head, \$150. Power steering rack & pump, \$75. Hood(orange), \$65. EFIcomputer, \$60. Int manifold +3 inj, \$40. Htr core & motor, \$20ea. Instr panel, \$25. Many other parts, prices negotiable. Frank Reinsel, 12110 Georgian Trail, St Louis, MO 63131. (314)965-6278.

99 parts, 75 L&R mirrors, \$15/pr. New 5Jx15 steel wheel, \$30. New rear brake seal kit, #8994527, \$10. New brake lt switch, #8530792, \$5. John Paschkewitz, 697 Lakeside Cir, Robins AFB, GA 31098. (912)929-3856.

99 Parts, new Ansa exhausts, rubber bumper covers, pads, alternators, clutches, lenses, FI parts, hatchback glass, hubcaps, cyl hds, used short block... Convert from A/T to 4spd, all parts incl rblt trans & clutch pkg. Charles Dodson, 7 Wainwright Av, Annapolis, MD 21403. (301) 267-9245.

99 parts from 74L & 78 GLE. PS, AC, interior, eng parts, glass & body parts for 2 & 4dr. Send SASE. James Mackay, PO Box 464, Wheaton, IL 60189-0464. (312)668-4438.

Turbocharger from 78 99. Wastegate & exh manifold. Recently rebuilt, but needs oil seal. \$150. Don Prizeler, Dayton, OH. (513)296-0668.

Sony XM-E7 Graphic Equalizer. Mike Rand, 122 E. 284, Willowick, OH 44094. (216)585-1288.

Blaupunkt Sacramento cassette radio, ARI ready, 2 6x9 BP spkrs, BP ARI adapter, \$230/all. 86 3-spoke steering wheel, \$25. +Shpg. Len Stavish, 116 Birch Ln, New City, NY 10956. (914)634-0521 after 5pm EST.

From 77 EMS, alloy wheel w/good CN36, new CN36, trailer hitch, new rear wheel bearings, roof rack, Bosch fog lites, factory manual. Tim Brown, 615 Plainsboro Rd, Plainsboro, NJ 08536. (609)799-5606.

Alloy wheels from 82 900S, good cond, run true, \$50ea +shpg. Rob Berube, 25 Dow Ln, Rye, NH 03870. (603)964-5800.

4 Cibie headlamps to fit 99. Quartz Halogen, replace OE headlts with no modification. \$35 +shpg. Ron Canaday, 6510 Leavenworth Rd, Kansas City, KS 66104. (913)299-4751

4 new steel wheels from 85 900, \$80. Mike Tucker, 2324 Davis Dr, Matthews, NC 28105. (704)846-4098.

4 new Bosch Electronic Fuel Injectors, (green) #0280150014230, \$50/all. John Fog, 9713 N. 56th Dr, Glendale, AZ 85302. (602)937-9128.

OE trailer hitch from 72 99 2dr. \$75. Ken Burson, 4213 Walnut, Omaha, NE 68105. (402)551-9665.

OE trailer hitch from 78 99 3dr. \$80 obo +shpg. Ted Fitts, LaCrescenta, CA. (818)957-2197.

Seat covers, green, from 79 900T 5dr. Rear new, front like new. \$75/set. Ben Lewis, 526 Oak Park, Ukiah, CA 95482. (707)462-4998.

Blue carpet floor mats for 900, exc cond, set of 4/\$35. Steel tire chains for TRX wheels, \$20. Dash panel inserts for 900, \$30. +Shpg. Terry Parsons, 3411 Bathgate Lane, San Jose, CA 95121. (408)274-0301.

4 Uniroyal Rallye 180 tires, 175/70x15, \$10ea or 4/\$30. Black air dam for 99, make offer. Dave Rosser, Richboro, PA. (215)357-2062.

New 900 manuals, 79-83 Serv/Maint, \$10. 85-86 Pre-Del/Brk-In, \$10. 79-80 Eng, & 79-85 Man Trans, \$15ea. V4 manual, \$10. 99 mirrors, \$15/pr. Clock, \$15. +Shpg. John Betsill, 3809 White Settlement Rd, Weatherford, TX 76086. (817)441-8583.

Early 99 hubcaps, new, \$20/pr. Dual blade windshld wipers, \$20/pr. Steve Anderson, 2521 Payne Rd, Des Moines, IA 50310.

Wanted, All Models

Experienced Off-Road racer with competitive Saab 96 (& Sonett) seeks sponsor and/or co-driver for 87 season & beyond. Wins include 79 Mexicali 250, 82 Parker 400 & Baja 1000, 84 & 85 Baja 500 & Parker 400. Car may be repainted for sponsor. Arne Gunnarsson, 38828 Harris Trail, Fallbrook, CA 92028. (619)723-9154.

Inner driver for 99 M/T, 70-on. RF Lower control arm for 70 96. John Grimmer, PO Box 155, Nashville, IN 47448. (812)988-6692.

4 Ronal alloy wheels wanted for 96. Also wheel puller tool for 96. Keith Bridges, 4305D Van Nuys Blvd, Sherman Oaks, CA 91403. (818)784-0758

For 64 850 GT, front resonator w/dual outlets, radiator, windshld wiper arm. Bill Mather, 8120 Prescott Dr, #T-1, Vienna, VA 22180. (703)573-1455.

For 73 Sonett, radiator hoses, driving lights. Andy Jessup, 290 N. Indian Av, Palm Springs, CA 92262. (619)325-2571.

Sonett V4 wanted, (not S-III) decent frame & body, bad engine. Mitch Madsen, 313 S. Broadway, New Ulm, MN 56073. (507)354-6158.

MEMBERSHIP/SUBSCRIPTION

Annual Membership/Subscription fees for the SAAB Club are as follows:

First Year	_____	\$18.00
Renewal	_____	\$15.00
Canadian	_____	Add \$3.00 US/year
International	_____	Add \$7.00 US/year

Individual back issues (1986 only) are available for \$1.50 each, 3 or more \$1.00 each.

NAME _____

ADDRESS _____

CITY _____ STATE _____ ZIP CODE _____

PHONE _____

SAABS OWNED _____

SAAB PARTS

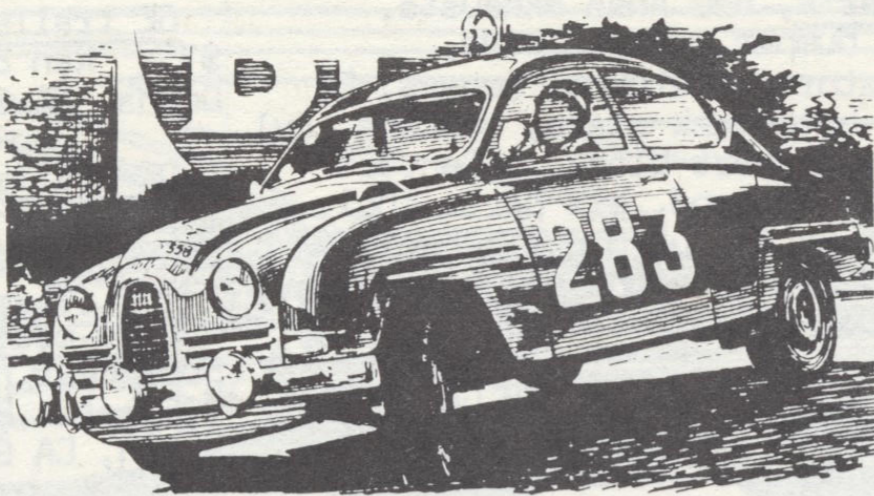

**HUGE INVENTORY OF FACTORY
PARTS AND ACCESSORIES FOR
V-4, 99, 900 and 9000**

**V-4 CATALOG, \$3.00
(REFUNDABLE)**



517 East Pike Street
Seattle, WA 98122

"THE ENTHUSIAST PARTS STORE"

SAAB
ROWLAND MOTORS

U.S.A. PARTS ORDER LINE

1-800-426-2202

WA STATE PARTS ORDER LINE

1-800-562-5510

INFORMATION, SEATTLE LINE

(206) 328-2303

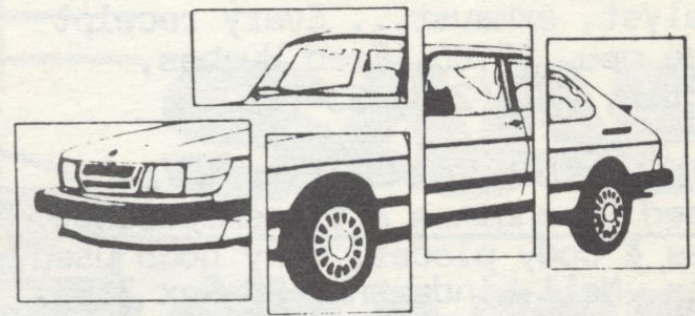

PARTS

E U R O P E A N
A U T O T E I L E
INC.

DISCOUNT PRICES ON
NEW, USED, REBUILT PARTS & ACCESSORIES

- BODY PANELS
- ENGINES
- TRANSMISSIONS
- UPHOLSTERY
- SUSPENSION COMPONENTS
- CLUTCH KITS
- TURBOCHARGERS
- COMPLETE LINE OF ACCESSORIES

EVERYTHING FOR YOUR SAAB!

WE SHIP DAILY • OPEN SATURDAY

1311 67th ST. • EMERYVILLE, CA 94608

(415) 654-9121

USA TOLL FREE

800-621-0851 ext. 111



2416 London Road, Unit 900
Duluth, Minnesota 55812

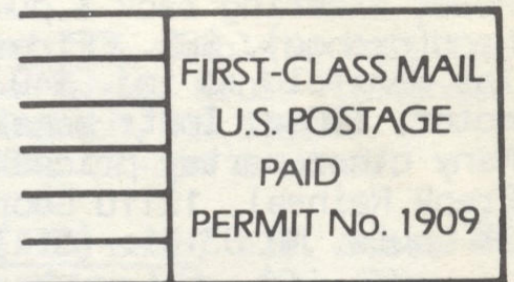
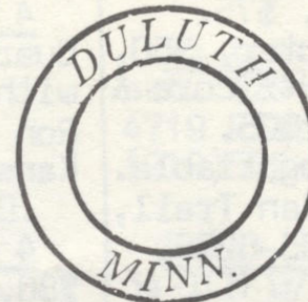

FIRST CLASS

FEB. 1977

Exp: 87 12 R