



THE SAAB CLUB

MAY 1985, NEWSLETTER #137

SAAB UNVEILS TURBO 900 EV-1

An experimental version of the Saab 900 Turbo EV-1 will be displayed at the Los Angeles Auto Expo, May 4-12, at the Los Angeles Convention Center. While there are no plans for production of the experimental car, the 2+2 seater sports coupe has been designed to enable Saab to test and study components and systems that may be of interest to the styling and functional features of tomorrow's production cars.

Body and Chassis Design

The Saab 900 Turbo EV-1 is a two-door 2 + 2 seater sport coupe, built of steel, using the floor plan and chassis of a three-door 900 Turbo. The car incorporates the front wheel suspension and the rear axle system of the Saab 900 with modifications such as a wider track, wider tires, and ventilated front brake discs.

The body is distinctly wedge shaped, but with a smoothly rounded rear section. The basic design is aimed at achieving optimum road behavior, by cutting down lift forces and

ensuring good stability, even at very high speeds. A distinctive feature of the EV-1 is the all-glass upper section with a Targa type top. The rear window and trunk lid are one integral unit.

The flush, light-alloy wheels are of a new design and play a vital part in the overall styling of the car. As flush wheels can prevent an adequate flow of air for cooling the brakes, wheel manufacturer Ronal was commissioned to design a new wheel. An ingenious arrangement on the inboard side of this new wheel forces the air to flow through three concealed holes on the outside of the wheel, to provide brake cooling.

More Powerful Turbo Engine

The Saab two-liter, 16-valve Turbo engine, was modified for the EV-1. The engine now develops 282 hp at 6,500 rpm, a peak torque has been raised to an impressive 246 lb. ft. at 3,500 rpm. The high torque starts to develop at moderate speed and continues right up to the peak engine speed of 6,500 rpm.

Continued on p. 3

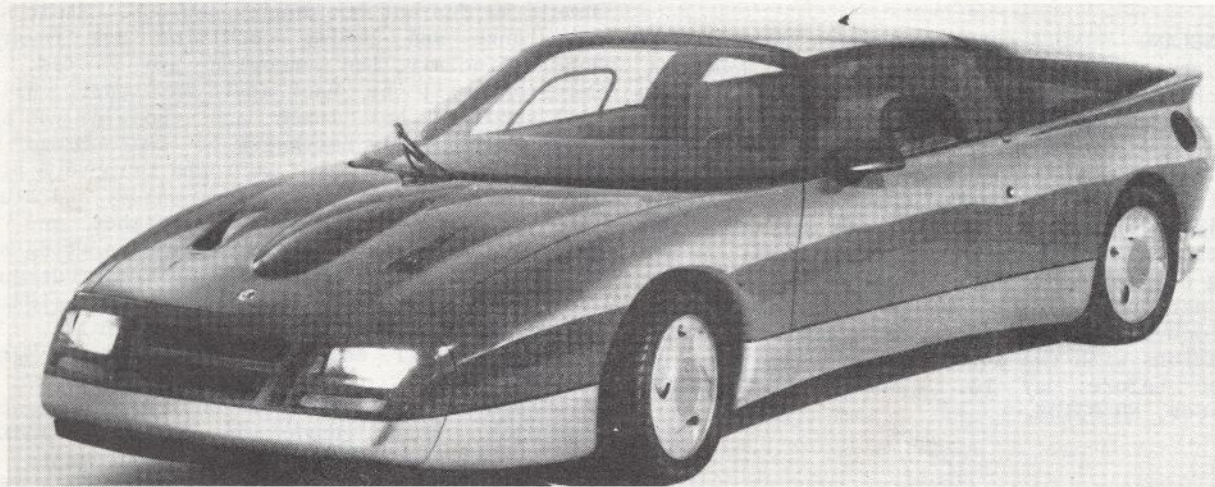

Saab 900 Turbo EV-1, an experimental sports coupe will be displayed at the Los Angeles Auto Expo, May 4-12.

Saab Clubs of North America

Editor and publisher: Jeff Delahorne, 5805 Oneida St., Duluth, MN 55804

(218) 525-3253 9 a.m.-8 p.m. except Sunday

Consultants: Dick Grossman, Jack Ashcraft, Carolanne Curtis, Andy Buc, Ted Tucker

CLUB NEWS

CENTRAL ILLIANA SAAB CLUB--The May meeting will feature a KWIK FIX KLINIC by Randy Riggs on May 19 at 2pm at Margrit Adler's house, 1507 W. University, 217-356-9244.

MID-HUDSON SAAB CLUB--(Rockland, Westchester, North Jersey) Saabers interested in forming a club should Lewis Eig at 914-352-6124.

ATLANTA SAAB CLUB--Meets the last Monday of the month at Carlos McGees at The Pardo. Dinner is from 7-8 pm with meetings starting at 8. Call Lou Savage for more info. 404-394-2310.

SAAB CLUB NATIONAL CAPITAL AREA--meets the Third Tuesday of each month at the Silver Spring Public Library, 8901 Colesville Rd, Silver Spring. For more info, contact Toby Turpin, 301-384-6732.

APPALACHIA SAAB CLUB--will be meeting the Third Tuesday of each month at Pennington's Fund Raising Co., 214 Market St., Johnson City, TN. For more info, call Mike Woods, 615-753-2101, or write Rt. 6 Box 349 Jonesborough, TN 37659.

WATKINS GLEN TICKETS--Saab enthusiasts interested in Sky Box seats for Watkins Glen events should contact Alexandre Barbier, 607-565-2711.

MILWAUKEE SAAB CLUB--will meet on May 20. For more info call 964-7463.

SOUTHERN CALIFORNIA SAAB CLUB--will have an Open House on May 18th, 126 1/2 Main St, Seal Beach, CA, 90740, 213-493-6707, 11am until ? The Club will provide a grill for whatever you want to cook.

NEW ENGLAND SONETT CLUB--will meet on Saturday, June 1 at the Terra Nova Restaurant, NH Route 3A, in Litchfield, NH from 1-4pm. This is our Annual Business Meeting for 1985. The business agenda includes the election of officers. In addition, Warren Adams, owner of Warren's Auto Body in Litchfield will discuss Sonett rust removal, fiberglass work, paint matching and polishing. We have reserved the entire restaurant area for the meeting but will have to guarantee attendance. \$4.00 per person will cover attendance and hot hors d'oeuvres. There will be a cash bar. Club reservations with the \$4.00 per person fee are required before May 13. NESC, PO Box 4362, Manchester, NH 03108.

MEMBERSHIP/SUBSCRIPTION

Dues for membership/subscription are as follows:

First year, third-class mail	\$14.00
First year, first-class	\$15.00
Renewal, third-class	\$11.00
Renewal, first-class	\$12.00

First-year membership includes two back-issue newsletters, Club tech sheets and emblem.

A collection of 15+ back issues is available for \$8.00

'85 CONVENTION UPDATE

CHAMBERSBURG '85! promises to be a memorable gathering of the faithful, Saabs from poppers to twin-cams will descend on Chambersburg, PA the weekend of July 26-28. Chambersburg, in south central Pennsylvania, lies in the lovely and storied Cumberland Valley. Chambersburg is familiar to many Civil War buffs, and Gettysburg is only a short hop away. Wilson College, a small women's liberal arts school dating from 1869, will be our central focus. Everyone will be lodged, fed and have most of our activities there. Wilson is situated on 300 partially wooded acres and is opening their facilities including pool, gym and tennis courts to us. Horses are also part of their program, with riding lessons available upon special advance application.

Saturday afternoon we plan a rally of some 38 miles northward into the eastern Appalachian Mountains. There in the Aughwick Valley we shall board, by special arrangement, the historic three-foot gauge East Broad Top Railroad. Built in 1873, and still steam-powered, this railway is the oldest original operating narrow gauge railroad in the eastern U.S. The Shade Gap electric trolleys will also be on hand. Just be sure you're on hand for this convention by reserving your place! Advance reservations are required and necessary to plan in detail our banqueting, excursions and other arrangements.

Basic Schedule: Friday, 26 July, 2pm - Registration opens at Wilson College. Rooms will have been assigned through your advance registration - dinner - social fete-keg party - Saab company films.

Saturday, 27 July - Table setups for the swap meet. Concurrently will be the first club concours. Four classes represented will be 92 - 93-95-96, 99, 900 and Sonetts. The concours should be fun but not deadly serious. Basic stock appearance and loving condition are rewarded. Robert Sinclair, Len Lonnegren and - yes, Erik Carlsson will be back again this year. Wilson will supply a box lunch and those of you still willing will rally northward to East Broad Top. The trains will take us round trip to a picnic area. In the evening, the banquet and awards, interspersed with disjointed speeches and loud guffaws, will cap off your day. Babysitting might be possible if you apply with your reservation.

Sunday, 28 July - Technical sessions and 'roundtable' discussions with Saab folks. The convention will end after lunch and the "group" picture.

Reservations should be sent to me here at the Saab Club. Full convention weekend, including 2 nights lodging in the dorms, all meals and activities is only \$89.00/person (double occ.), \$105.00 (single occ.-limited availability. For those of you staying elsewhere but eating meals at the college, remit \$65.00 (no lodging). Saturday activities only, \$45.00. The railroad trip is \$5.00 extra per person. We urge everyone to arrive early on Friday and be part of the entire weekend planned. Register now and don't be left out. We want you and yours and your Saab!

Carolanne Curtis, Convention Coordinator

SAAB 900 TURBO EV-1, continued from p.1

Engine output has been boosted by increasing the size of the intake and exhaust systems for higher gas flow rates. A larger turbo charger has also been installed and the capacity of the fuel system has been increased. The compression ratio has been reduced to 7.2:1, which makes it possible to raise turbo boost pressure to 15.6 psi.

The engine block, valve mechanism, crankshaft and all bearings are of standard Saab design, but the engine incorporates forged pistons and reinforced connecting rods. As in the Saab 900, the engine is mounted longitudinally.

The drag coefficient is a low 0.32, which multiplied by the small frontal area of 1.72 square meter, gives the low CdA value of 0.55. The estimated top speed for the EV-1 is 168 mph, and acceleration from 0 to 60 mph is estimated at 5.7 sec. The time for the quarter mile run from standstill is approximately 13.9 seconds.

Ventilation with solar cells

Although the large glass surfaces of the EV-1 are heat-reflecting, the interior will obviously absorb a large amount of solar heat. To reduce this heat the car features a novel, continuous ventilation system for the interior.

The removeable glass roof over the front seats incorporates 66 solar cells. These are connected in series and power an electric fan in the ventilation air exhaust. The stronger the sunlight, the faster the fan will run. The interior will be ventilated automatically, whenever the car is parked in the open on a sunny day.

New Generation Headlights

The Saab 900 Turbo EV-1 is the first car to be fitted with the new Hella compact headlights. The lamps incorporate separate light sources for full beam, low beam, and running lights. Although the light opening is very small and the lines of the car extremely low and sloping, the light intensity from the new headlights is higher than that from present day conventional lights.



Solar cells in the roof provide power to interior cooling fans.

V4 AIR CLEANER MODIFICATION

Here is an easy modification to the V4 air cleaner for those of us who have lost those 10mm hex bolts and are using the big sheet metal screws or wire to hold down the air cleaner. Drill the holes in the valve cover tabs with a 7/32 inch bit and tap for 1/4-20 threads. Drilling may not be necessary if the holes have already been enlarged. Next get two 1/4 inch hex bolts about 1.5 inch long and threaded all the way. Screw them from the back (carb side). Before the bolts seat, apply Loc-Tite liberally to the last 3/8 inch and tighten down firmly. Now you have permanent stubs to slip the air cleaner tabs over. Secure it with a flat washer, a lock washer and a wing nut on each side. Now you can easily remove and replace the unit without tools.

Fred Sisson, Norcross, GA

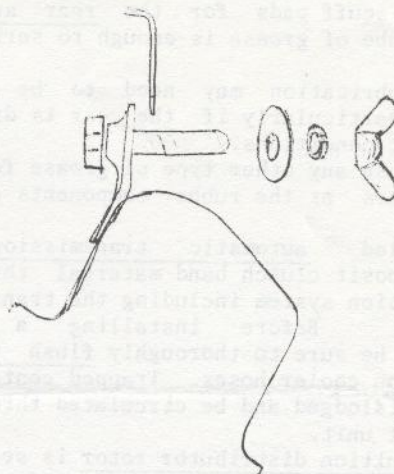

SWAY BARS ON '72 96

Regarding the addition of a front stabilizer (sway bar) to a 72 or later 96, Saab re-routed the metal fuel line running through the engine compartment when they did away with the bar. If you add the bar with the engine out you will see that the bar can run through this line and eventually cause a leak and fire. If you add the bar with the engine in you won't notice this at all, as was my case until a transmission exchange uncovered the potential for disaster. My metal fuel line was more than half way worn through. Routing the fuel line as in a pre-1972 92 solved the problem.

Stephen Butler, San Jose, CA

TIPS FOR SONETTS

If you want to go fiberglass crazy, glass over the vent holes behind the small rear windows to prevent possible water leakage. Also glass over the windshield wiper water spray nozzle holes in the hood. I replaced the original wiper blades with ones that had an integral washer spray built on them. I used the WX2 dual wiper blade. If your wiper motor is not working strongly, I do not suggest using these wipers since each wiper has 2 inch blades and will tend to work the motor a bit more than the original wiper blades.

Pete Briggs, Thibodaux, LA

SAAB SERVICE TIPS



SAAB SERVICE TIPS, MARCH, 1985

A special non-petroleum grease is now available to lubricate the mounting bushings of Saab anti-roll bars (Turbo with SPG). Bushings which are not properly lubricated will cause a "groaning" noise as the car is driven on rough roads.

To re-grease the bushing it is necessary to loosen the mounting of the front anti-roll bar and work the special grease (p/n 00-26-575) into the bushings. The same grease may also be applied at the 4 rubber scuff pads for the rear anti-roll bar. One tube of grease is enough to service one car.

This lubrication may need to be re-done eventually, particularly if the car is driven in extremely wet conditions.

Do not use any other type of grease for Saab anti-roll bars as the rubber components could be damaged.

A failed automatic transmission will generally deposit clutch band material throughout the lubrication system including the transmission oil cooler. Before installing a rebuilt transmission be sure to thoroughly flush the oil cooler and the cooler hoses. Trapped contaminants may become dislodged and be circulated through the newly rebuilt unit.

The ignition distributor rotor is secured to the distributor shaft with LOCTITE 609 on all 16 valve Turbos. The loctite is used to secure the rotor to the shaft and make it more resistant to vibrations from the engine. Should the rotor ever need replacement, the replacement rotor must be secured as well.

A. Remove the old rotor by crushing it with a pair of channel locks or equivalent pliers. Do not exert excessive sideways force on the shaft.

B. Clean any residue of old loctite with Locquic Primer (p/n/ 02-06-045) and apply a very thin coat of Loctite 609 (p/n/ 02-06-037) to the shaft.

C. Fit the new rotor and all to set-up for 1/2 hour before driving the car.

A new clamp has been introduced into car production which secures the wiring harness in the engine compartment to the firewall. The new clamp replaces the cable tie which secured the harness at the heater hoses. This change is valid from VIN Serial Nos. F1023354 and F2011656.

Be sure to re-secure this wiring harness properly if it has been disturbed or removed for any reason.

When replacing the black insulation at the AC evaporator (see Service Tips June 1984) be sure to use the type sold by an airconditioning supply company such as Murray, ARA or Delco. Poor quality insulation could fall off the evaporator housing and get tangled with the drive belts. It is a sound practice to inspect the condition of this insulation during the routine services.

NEW CLUTCH RELEASE TOOL, M85

Saab Service Info 03/85-747: Beginning with model year 1985, a new clutch release bearing was introduced which requires the use of a new release tool. The new tool p/n 83-94-033 may be used in place of the old tool when working on all Saab 900 and the 99 from 1976-80 with manual transmission. The old tool (p/n 83-93-175) is being discontinued.

The clutch release tool is used to depress the clutch release bearing in order to install the special spacer ring (p/n 83-90-023) between the clutch cover and the diaphragm spring.

When this is done, the slave cylinder and release bearing may be removed together.

As an alternative to using the release tool, the clutch pedal in the car may be depressed to install the spacer ring. However, this method only works when the power unit is in the car and the slave cylinder is functional.

SOURCE OF NOTCHY SHIFTING IN 900s

Whenever a 900 is tested in a magazine there is often a complaint concerning notchy shifting, and from time-to-time, there are letters in the newsletter about difficult shifting and/or difficulty engaging first gear. One or two even mentioned it was especially hard shifting into first when pointing uphill.

Well, the other day, I had this experience. Repeated engagement did not ease the difficulty of getting into first. Normally, the first engagement may be somewhat notchy as the syncro teeth may not be lined up, but repeating the engagement a couple times should line things up and the lever should go in like a knife in warm butter (assuming the car has not moved any). Since it did not, it indicated the clutch was dragging. I had the "brilliant" idea of a simple test. I turned the car around and tried engaging first again. It worked fine! I then pointed the car back uphill and once again it was difficult to engage first gear. My conclusion--the disc is "falling backward" on the clutch shaft spines and dragging on the flywheel. Almost seems too simple doesn't it? Why the disc doesn't "fall forward" and drag on the pressure plate, I do not know. Unfortunately, I do not have a solution for it at this time either.

Of course, clutches can drag on all cars (not just Saabs) while the car is on the level also, resulting in notchy, difficult shifting. Possible causes would be problems in the hydraulics, worn pedal pivot, warped clutch disc, a clutch disc sticking to the flywheel or the pressure plate (my car sometimes suffers from this) or a clutch shaft dragging in its flywheel bushing.

I am wondering if the new clutch slave cylinder (p/n 87-22-209) change detailed in the March newsletter will help eliminate notchy shifting complaints? The '85 naturally aspirated models have gone to an asbestos-free clutch material

Steve Parsons, Washington, IL

CORRECTING AC EVAPORATOR ICING, M80-85

Saab Service Info 01/85-732: AC evaporator icing may occur if the location of the thermostatic switch capillary tube is incorrect or the switch has failed. New capillary tube locations in the evaporators have been developed for 900 models from 1980 to 1985 that should keep the risk of icing to a minimum. (Note: M79-early M80 90's with "VIR" AC systems do not have this thermostatic switch.)

Should icing occur, refer to the capillary tube location and troubleshooting described below.

M80-83 Models

1. Withdraw the capillary tube and mark the tube with a wrap of tape 130mm from the end of the tube. This insures that only the correct length (130mm) will be inserted into the evaporator.
2. Work the tube into the evaporator at the angle and location described in drawing 1. Check that the recirculation door move freely.
3. Test the system. Should icing still occur, replace the thermostatic switch (p/n 85-93-766) and again correctly locate the tube.

Note: Some 1981 models may have insulating foam instead of black "tar strip" insulation and may not use these procedures. Instead refer to the locations recommended in Service Manual Section 8 (p. 854-36).

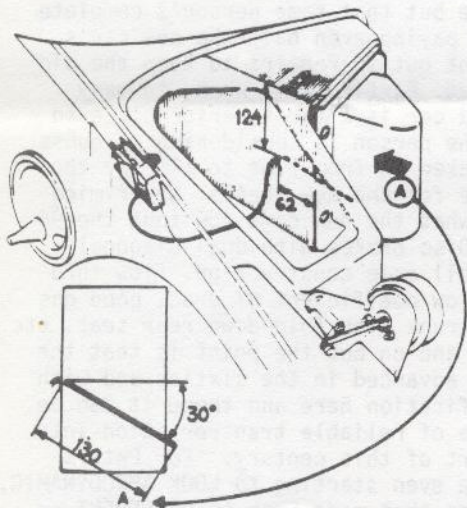

130 mm = 5 1/8"
 124 mm = 4 7/8"
 62 mm = 2 7/16"

M84-85 Models

Before re-locating or installing a new thermostatic switch, the evaporator must first be identified as to brand of manufacturer (Borletti of Sanden). Both types are still being fitted during production.

Borletti--The flanged nut (1) at outlet pipe is mad of copper.

Sanden--The flanged nut (1) at outlet pipe is made of aluminum.

M84 - with Borletti Evaporator--follow procedures outlined for M80-83.

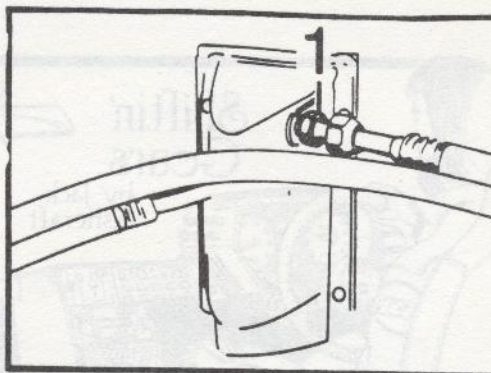

Evaporator as from 1984 model cars
 Copper = Borletti
 Aluminium = Sanden

M84 - with Sanden Evaporator--

1. See step 1 above.
2. Work the tube into the evaporator at the angle and location described in drawing 4. Check that the recirculation door moves freely.
3. See step 3 above.

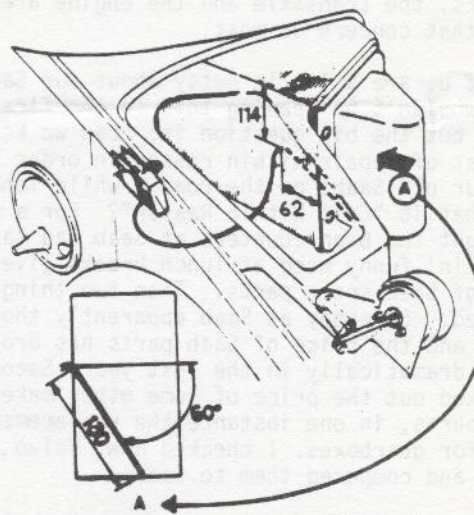

(drawing 4)

SPORTS CAR SERVICE, INC.
 4616 Governor Printz Blvd. Wilmington, DE 19809
 (302) 654-2278
 Specializing in SAABS since 1956

Spring Tune-up Specials
 All tune-up specials include:
 Air and Oil Filter, Points, Cap, Rotor, and Plugs.

95-96 - '68 on \$19.95
 Sonetts - '68 on \$24.95
 99-900 - '69-80 \$19.95

To save C.O.D. charges add \$4.00 for shpg. and hndg.
 Please specify year.

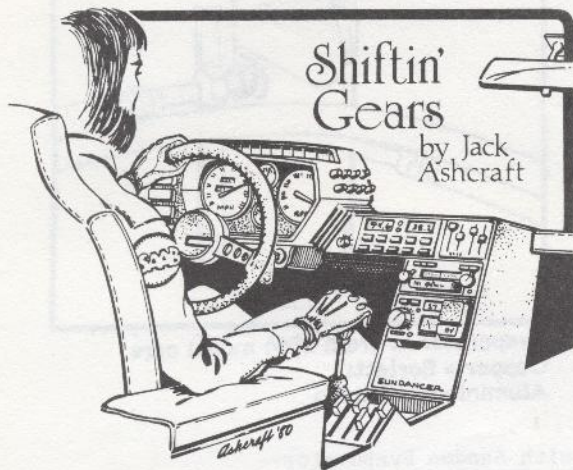

THE SAAB 96 IN MODERN TIMES

Face it folks: most Saabs of the V4 persuasion are approaching, or have already exceeded, 100,000 miles. If we disregard the idiosyncracies of the body and chassis that tend to occur at high mileage (and extended years), the hydraulics, the transaxle and the engine are the items that concern us most.

Most of us are a little nutsy about our Saabs or we wouldn't be reading this in the first place, but the big question is: can we keep the cost of repair within reason in order to keep our old Saabs on the road a while longer? Just what is "Cost Within Reason"? For a while I thought the bean counters at Saab had taken to smokin' funny weed at lunch breaks given the price of Saab spare parts. Then two things happened. Somebody at Saab apparently thought so too and the price of Saab parts has dropped fairly dramatically in the last year. Secondly, I checked out the price of some other makes spare parts, in one instance the replacement parts for gearboxes. I checked BMW, Volvo, and Datsun and compared them to Saab.

BMW parts prices nearly gave me a catatonic fit on the spot! BMW, already the world's third most overrated car (Porsche and Mercedes are King and Queen in this nutball trio), gets prices for a gearbox that equal a good used car in many areas. Volvo is not much better. Datsun --a high volume builder--is still at least as high priced as Saab, part-for-gearbox-part. Truth of the matter is, brothers and sisters, inflation has gotten to all of us.

If you are going to rebuild a Saab 96, you are going to invest some serious money. Is this "Cost Within Reason"? Every owner must answer that for themselves. If the gearbox or the engine is the only thing wrong with the car, then it is probably within reason. Even if both need rebuilding, it is probably within reason.

All you have to do is check the window sticker on the current crop of plastic junk to tell you a Saab 96 is worth fixing, in many cases. How much down payment do you have to scratch up to buy a new Saab, Volvo, or Merkur? Leave out the Datsuns, Toyotas, and Subarus--they are not in the same league as the Saab 96. Quite probably the down payment will easily handle the repair of a V4 engine and gearbox!



Then given the monthly payments of \$250-300 on the new car, it would not take long to have your old 96 BETTER than new, a LONG time before you got your new car paid for.

I have never understood a person's willingness to pay big payments for a new car over a long period of time but that same person's complete abhorrence of paying even half the new car's monthly payment out in repairs to keep the old one on the road. Particularly when, in many cases, the old car is a far superior piece to the new one the person is considering. I guess we all get taken in from time to time by the ad agency hype for the new wheels. Never mind that most of what the new cars now tout the 96 had in 1962: Disc brakes with dual diagonal connection, roll cage construction, flow thru vent system, low coefficient of drag, good gas mileage, big trunk with fold-down rear seat, etc. I could go on and on but the point is that the Saab was very advanced in the sixties and with a little modification here and there it can be a viable piece of reliable transportation into the latter part of this century. For Pete's sake, cars are even starting to LOOK AERODYNAMIC, the very things that made Saab so DIFFERENT or UGLY, depending on the viewpoint all these years!

What can help your budget on Saab repair is NOT to pay for any more high priced mechanic labor than is absolutely necessary. Do as much of the work as you can yourself. Pay a mechanic to show you how a tune up and valve adjustment is done--one time. Then do it yourself. Do your own oil changes, lube jobs, and clutch adjustments. Change your own brake pads and shoes. Buy a Saab shop manual, ask advice of other club members and of known GOOD Saab mechanics. Go to Saab maintenance seminars. Read the newsletter and substitute Ford or other lower cost (due to higher production volume) parts whenever possible. DO NOT ask advice of your local shade tree Ford or

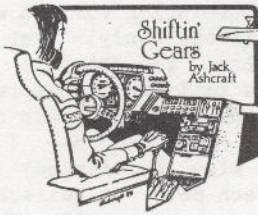

Chevy mechanic unless you just adore frustration and ridicule. And keep your perspective. This is an era of \$10000 throwaway plastic cars. Your Saab 96V4 is just as strong, safe, and reliable as it ever was and you can keep right on enjoying it for years to come. But realize that a pound of coffee costs six times what it did in 1968. Is that a reason to throw your old Saab away? Its water pump, after all, only costs about three times what it did in 1968. Check around and see what the prices are on some other cars before you make the decision to trash your Saab.

Part of the problem is that many 96V4 owners have enjoyed literally YEARS of trouble free driving and now that the old girl is getting weary and ready for some TLC and a few parts these same owners have to face up to the fact that it isn't 1968 any more. When your Saab gets to, or over the 100,000 mile mark, its going to have to have some major work done before long and it is going to have to be done at 1985 prices.

But again I say to you: you can change a lot of parts on your Saab 96 for the down payment on a new one. And you can keep it running a long time for the monthly payment on a new one. Think about it.

THE GENERAL GOES SPACE-AGE

Recent motoring journals are reporting the entry of GM into the space age with the new Saturn car. This sophisticated piece of wheeled transport is, by all accounts, a marvel of bean counting from the very onset. Ostensibly, bean counters, car stylists, production and mechanical engineering people all sat down at the same table with a blank sheet of paper and then had at it together instead of in series as had been done in the past.

Well, what is it exactly that these high powered committees have fathered? A weapon to beat back the foreign hordes? I doubt it. A car that will be all things to all people? Hardly. A car that can be constructed so simply and so cheaply that the Japanese themselves can't compete with it in the market place? Fat chance. What they have here is a car that is more computer designed, and robot built than ever before, a car that IS built cheaper than ever before, and IS hyped to be all things to all of us, BUT most of all, a car that will show more PROFIT than ever before. That is

what the General is better at than almost anybody else, except the Japanese, and Mercedes-Benz.

Look for a lot of plastic and thin tin, a lot of video game interior flash, and more advertising hoopla than it took to launch the Apollo program. Will it be a success? Of course. The General does his homework well. It will probably sell like cold beer at a frat house picnic, have the usual ability not to offend (or particularly delight) anybody, and not be recalled at a rate higher than 3 million units a year.

THE QUOTA

Posturing, as opposed to real negotiations, is taking place between governments at this time. Mr. Nakasone and Mr. Reagan are allegedly doing sumo numbers on one another to produce a more equitable tariff situation between this country and Japan. While this applies to a number of products, the automobile quota has been the most visible bit of political insanity in recent years. The quota--so highly touted by Mr. Iacocca as being the salvation of the US auto industry--has had one big effect: it has run the price of the automobile out of sight in this country.

The Japanese, who ordinarily would bring in anything that could be produced at a profit and certified for sale, just brought in the high ticket stuff. More profit per unit sold is the name of that game. The US builders love it because they can sell their junk at high prices and make more profit than they could if they had to compete with lower priced imports. As usual, the buyer takes it in the neck.

Rest assured the government isn't going to do more than give lip service to any big changes in this area. When both big business and the unions are all for something, and the consumer is the only one thats unhappy about it, what do you think about the possibility of a change? Slim and none. Some things just dont seem to change much....

COMING UP NEXT:

ARTICLES ON:

- 1--Engine rebuilding the RIGHT way, with less expensive parts
- 2--Gearbox rebuilding, OR, the need to neuter
- 3--Cheap(er) hydraulics for the Saab 96

Go Swift • Go Safe • Go



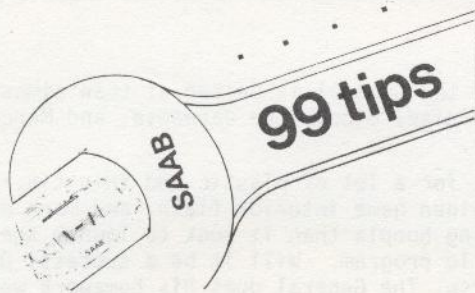

RADIATOR FAN MOTOR FIX

By Bill O'Neil, Cincinnati, OH

Having lived with our '78 GLE for almost two years now, I'll make the following comments.

1). The wipers now have a mind of their own and will not shut off consistently. I have replaced the intermittent relay, disassembled the Lucas (shudder...) motor to check for wear and found it to be in fine shape, have even disassembled the stalk switch and reassembled it via staking the die-cast posts. I cleaned the switch, checked its operation with a continuity meter and found it to be okay. For a while the new relay seemed to have cured the problem, but now we're back to "will it or it shut down when I turn it off?." Frustrating and not a cheap "fix". The \$55 relay admittedly has a board with lots of components. Someone has mentioned that a bad ground at the motor could be at fault. Any ideas?

2). There is a rough idle and dying from time-to-time. I think it's the auxiliary air valve not closing down, which I have to inspect, lube and/or otherwise fix tomorrow.

3). There is a radiator fan motor problem. I seem to have read about many problems with this component, or system. In my case the motor stopped suddenly on a hot day when I was 100 miles from town. It overheated and blew the fuse. I tried new fuses. The motor would kick over, the fuse would blow. Fortunately, we were headed into winter weather, so I was able to keep the temp gauge in the safe zone for several months. Finally I had time to analyze the problem. An ammeter across the fuse showed 25-30 amp draw on a 10-12 amp motor. I took the motor out and disassembled it. The brushes were fine but at the fan end there was a curious and maybe unique failure (see diagram). At a \$125 replacement cost, I thought I'd see if I could fix this one myself.

Here's the fix. Have the armature checked on a growler. Although this one checked out okay electrically, enough of the insulation varnish was blackened on 2 windings (front only) that I decided to rewind those 2 poles. You can have it done, or as I did, buy a roll of "transformer wire" at a good electronics/radio supply house and do it yourself. In this motor's case (an Electrolux, although SWF may also be fitted) 17 turns of #22 (I think) on each pole. I believe a 100' spool of Belden wire was about \$8. When unwinding the damaged poles, be sure to count the number of turns and pattern/direction. It pays to mike the original wire carefully and match the gauge, obviously. When assembling, make a few extra "hits" on the bearing retainer stake-over (new positions) to assure security. The brushes have to be held back by heavy thread or fishline when installing the rear housing to the motor case. So instead of \$125, one can spend a couple hours and less than \$10 to cure one of the fan motor circuit's problems.

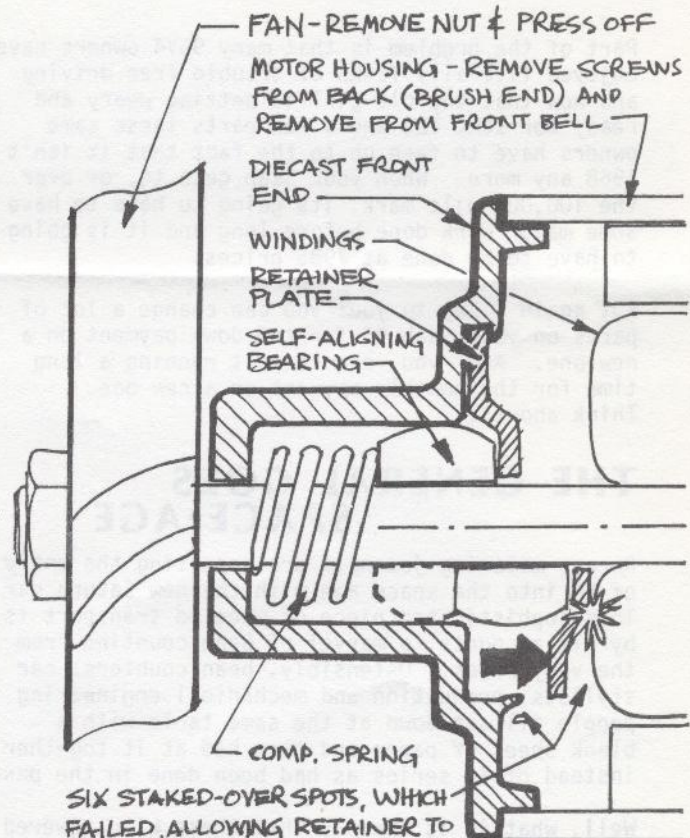

SIX STAKED-OVER SPOTS, WHICH FAILED, ALLOWING RETAINER TO BE PUSHED BACK AGAINST ARMATURE, CAUSING SHORT AND INCREASED FRICTION (IF YOU THINK YOU MIGHT HAVE THIS PROBLEM, SPIN FAN BY HAND... SHOULD ROTATE EASILY. IF NOT, YOU HAVE MECHANICAL DRAG. (THIS MOTOR RAN AT 25-30 AMPS, JUMPING THE FUSE)

ON A '78 GLE AT LEAST, ONE CAN REMOVE THE CASE WHICH HOLDS MOTOR & FAN, WITHOUT REMOVING THE RADIATOR ... DRAINING, ETC.



REPLACEMENT TURBO FOR SAABS!

Improved throttle response, increased power, improved driveability and eliminates use of engine oil to lube turbo with the Aerodyne turbo for your 1979 thru 1985 Saab turbo. Call or write

George's Imports L.T.D.
7746 Wornall Road
Kansas City, Mo. 64114
816-333-6582

PARTS MART



CLASSIFIED AD RATES

Ads offering parts or Saabs for sale or wanted at prices under \$200 are FREE to members and non-members. 25-word limit, plus name and address. Ads listing prices of \$201 to \$900, enclose \$2. Ads listing prices \$901 to \$2000, enclose \$5. \$2001 and up, enclose \$10. All ads without a price listed, enclose \$10.

Commercial ads: contact Editor for rates and info. We will delete all unnecessary superlatives and abbreviate where possible. Please enclose sufficient funds with ad copy; we will not bill.

CLASSIFIED AD DEADLINE

The Classified Ad deadline for the June issue will be May 16, and the deadline for the July issue will be June 19.

SONETTS FOR SALE

1969 Sonett V4, no-rust, A2 car, eng. exc., recent exh., approx. 50,000 mi, driven daily: \$3000. Ken Fogate, POB 326, Minong, WI 54859, 715-466-4872.

1970 Sonett III, #70500226, MSS cam, carb & exh.; rblt trans, engine & many mechanicals; am-fm, int. fair, stored most winters: \$2000. Dan Beaubein 3433 Pierce St., Sioux City, IA 51104, 712-258-6953.

1972 Sonett, beige w/brown strips, paint good, new tires, batt., alt., am-fm stereo, runs well, CA car: \$2800. George Hrachiari, 30945 Sutherland, Redlands, CA 92373, 714-794-5409.

1972 Sonett, 56,000 mi, clean, much new or rebuilt, very good cond, needs left front brake bearing work, have some parts: \$1800. Conrad Alexander, 3209 S 52nd Ct, Cicero, IL 60650, 312-863-7506.

1973 Sonett V4, #000141, 99K mi, am/fm, extractor exh., red decent body & int. Strong eng. & trans.: \$2900. Art Olive, 612-638-4397 days.

1974 Sonett III, strong V4 eng., trans. recently rblt, ready for body & frame restoration. Can help locate new parts: \$850. Bill Ross, 1114 Riley Rd, Aurora, OH 44202, 216-562-4394.

1974 Sonett, original in exc. cond., driving lites, stereo, spares, garaged, 78K mi.: \$3800, Ian Watson, 619-268-3958.

1974 Sonett III, yellow, rblt trans., Weber carb., extra eng., all manuals: \$3500. Jim Shane, 312-426-2759 eves.

1974 Sonett III, 60,000 Mi., baja red, very good cond., spare tire never used, MSS exh. w/nes muffler, fact. manual, fact. driving lights, exc. running cond.: \$3800 firm. Mrs. Lindstrom, 612-489-8763, St. Paul, MN.

95's and 96's FOR SALE

96, rblt trans. & front brakes, good eng. & tires, bad body: \$195 firm. Jon Jan, Pittsburgh, PA, 412-393-5559 wk, 621-2764 h.

1967 96, V4, 131K mi., lt. blue, orig. paint, body exc, CA car, no rust, good eng., runs well, noisy trans., decent int., many rblt parts, must sell: \$996.96. Tom Remedios, 1191 Bucknam Ave, Campbell, CA, 408-866-1689 h, 945-9400 x380 wk.

1967 96, 3 cyl., body good, eng. bad with spare bad eng., stored inside for 5 years: \$200 obo. Ray Twite, New Richmond, WI, 715-246-6373.

1967 96, 3 cyl., '69 V4, '72 V4. None run, extra parts, lit.: All for \$750. Bill Pensar, POB 1, Lemon Cove, CA 93244, 209-597-2504.

1970 96, good eng., bad trans., rusty, good tires, complete: \$199. 1971 96, good drivetrain & eng., solid body, exc. orig. int., many spares: \$1000. Tom Franko, 3512 Mayfair St, McKeesport, PA 15132, 412-672-6622, 4-11pm.

1971 & 1972 95s, exc. bodies, good engs. and ints., both need trans, many spares: \$500, also complete exc. set of chrome trim for 95 rear: \$50. John Belyea, 531 Main St, W. Boxford, MA 01885, 617-352-2720.

95, 96, and SONETT PARTS FOR SALE

For '69-73 96, outside rearview mirrors, \$15 ea; complete front or rear bumper \$50; complete red vinyl fr seat ass'y \$25; owner's manual \$9; hood \$10; upper control arms \$5 ea; windshield \$25; alternator \$20; rear axle \$20. Shipping or ins. not inc. Tom Franko, 3512 Mayfair St, McKeesport, PA 15132, 412-672-6622 after 4pm.

Parting out '71 96. All parts cheap or will sell complete less drivetrain for \$75. Fred Furrer, W12464 Boots Rd, Wisconsin Dells, WI 53965, 608-742-3881.

1500cc V4 eng. w/rblt heads and Solex carb + good trans. \$300; 3 Goodyear Arrivas on 96 rims (2K mi.) \$125; many more parts, must sell all. SASE for list. Drew Cullen, 117 Ashdale Ave, Syracuse, NY 13206, 315-432-0714.

15 95, \$ 96s for parts. Some good bodies & body parts, much misc., fair prices. David Brown, 1822 S 7th St, Minneapolis, MN 55454, 612-338-4210.

95, 96, & SONETT WANTEDS

Wanted for 1970 95/96: front upper chrome moulding for left side with attach. clips. Tom Cox, 301-465-6691 eves.

Wanted for 1972 Sonett III: rear window latch, tinted door windows, headlight rings. Fred Furrer, W12464 Boots Rd, Wisconsin Dells, WI 53965, 608-742-3881.

95, 96 & SONETT WANTEDS, continued

Wanted: driver's side window crank mech. for 1969 Sonett II. Offer \$30 + shipping costs. Mike Owen, 8052 Farmingdale, Germantown, TN 38138, 901-754-8914.

99's and 900's FOR SALE

1972 99E, automatic, 90,50 mi., eng. quit & is out, set of eng. gaskets, factory & Haynes manuals; 2/3 gal. matching lacquer: \$600. Mark Wilkinson, 6084 Mary Lane, Oconomowoc, WI 53066, 4140567-4169.

1973 99LE, ex. mech., 20K mi on complete eng./clutch/cv joints/brake job, rough int. and fr fender: \$500 firm. Brian Harris, Rt 8, Box 56, Abingdon, VA 24210, 703-628-3799.

1974 99LE, 4dr, complete except for eng. & trans.: \$125 or will sell parts. Mitchell Lemmo, 203-32-7457 eves.

1975 99 EMS, black, good cond., no rust: \$2000 obo. Vicki or Fred Ramey, 404-262-9835.

1976 99GL, rolled 3dr, no hood or windshield, 4sp: \$300. Scott Wolf, 4171 Cates St SE, Prior Lake, MN 55372, 612-447-5864.

1977 99GL, 5dr, 4sp, am-fm 8 track, AC, cruise control, new clutch & fuel pump, 110K mi, body good: \$2495. Chip Taylor, 215-572-0706 day, 947-4319 eves.

1977 99, 5dr, 4sp, 118K mi., EMS wheels, am-fm stereo cass., orig. owner, good cond. w/many new parts: \$2000. Bill Grace, 10313 Holme Lacey Ln, Austin, TX 78750, 512-331-1229.

1978 99 Turbo, anthracite, 104K mi., needs new head, body & int. very good, new KYBs, new turbo, dealer maint., new MXL's on alloy wheels negot.: \$1500 obo. Mike Vosburgh, 617-435-6743 h, 589-6706 wk.

1978 99 Turbo, 3dr, sunroof, airdam, rear spoiler, am-fm/CB, alloy wheels, black w/red velour int 34K mi., exc. cond.: \$6450. Rick Erickson, 743 Maple, St. Louis, MO 63143, 314-781-7202.

1979 900 EMS, metallic blue, Inca Turbo wheels sunroof, am-fm cass., runs good, needs some mech. & body work: \$1450. Bill Keene, NW Suburban Chicago area, 312-459-0728 after 6:30pm.

1980 900 Turbo, 5dr, 5sp, green, exc. cond., all serv. rec., alarm sys., cass. stereo, 48K mi.: \$6900. Michael Corder, 805-872-2169 or 326-2200.



KYB Shocks \$25.50 each incl. UPS

Fiberglass body parts, flared fenders, hood and front lid. Call for prices.

See our ads in the March April Newsletters for other special prices available to Saab Club members.

22 N 2nd St, Duluth, MN 55802 (218) 727-1814

99's and 900's FOR SALE, continued

1980 900 Turbo, 5dr, 5sp, green, 30,000 mi serv. just done, new muff.: \$7000 or trade for newer 2dr S. Nick Laubenthal, 319-338-4750.

1981 900 Turbo, 4dr, brown w/rust int., exc cond., loaded, alarm sys., 68K mi., automatic, garaged: \$7495 firm. Donald Knapp, 415-889-7874.

1983 900 Turbo, black, 3dr, 5sp, exc. maint., always garaged, orig. owner, low mi., exc cond., many xtras: Asking \$14,000. Call for details. Steven Bendror, 516-883-4749.

Saab 99 SCCA GT-3, ready to go, fuel cell, full cage, fully sorted suspension, Webers, MSS, plexiglass, slicks, rains, Bilsteins: \$4000. Larry Gesch, 414-442-7836 days, 353-1965 eves.

99 & 900 PARTS FOR SALE

2 Headlights complete for 1980 Turbo \$100 or will trade for Michelin TRX tires. Nick Laubenthal, 319-338-4750

Rear seat cushions for '78 99, tomato red, good cond. but soiled \$20 obo. Glen Anderson, 608 Whitehills Dr, East Lansing, MI 48823, 517-332-3726.

2 Cibie Euro Headlights with 55 watt low beam & 100 watt high beam + spare bulb \$45; TRX wheel locks-McGard \$10; spare tire/wheel with hubcap \$20; Haynes 900 manual \$6. All plus shipping. Tom Middleton, 325 Foxfire Dr #216, Oxford, OH 45056, 513-523-7343.

4 locks keyed alike \$20; starter \$40; alt. \$40. All from 1970 99 already disassembled. Write or call for complete price list. David Garwood, 5 Birch Ln, Scotia, NY 12302, 518-399-3636.



Ball Joints

Upper & Lower, '69-85-----\$13.99

Tie Rod Ends

Early-'74-----\$12.95

Late '75 On-----\$13.95

Brake Rotors

'69-74 front-----\$23.25

'75-80 front-----\$21.50

'81-85 front-----\$27.99

'69-85 rear-----\$23.25

Brake Pads

'69 & up rear-----\$6.95

'69-74 front-----\$9.95

'75-mid 76 rear-----\$7.95

'75 & up front-----\$8.95

Mann Oil Filters

2 liter-----\$1.99

Fuel Injectors

'75-79-----\$13.95

'80 & up-----\$14.95

#3 Brickton Road Route 4
Princeton, MN 55371

Phone: 612-389-3776

99 and 900 PARTS FOR SALE, continued

EMS wheel for 99 \$50; Saab sport steering wheel \$50; '75 dash cluster less clock \$20, 99 starter solenoid (new) \$10. Bill Grace, 10313 Holme Lacey Ln, Austin, TX 78750, 512-331-1229.

For '75 99 dr dist. with curve, header, radiator, steel wheels \$15; EMS \$50; head \$120; fuel dist., half shafts, glass, hitch, other parts, '74-4sp. Rich Chenet, RD#2, Box 181, Aliquippa, PA 15001, 412-495-3633.

1969-74 Saab service manual \$40; cruise control for '74 99 \$50. Warren Brecheisen, 91 3rd St, Hudson, IA 50643.

4 Pirelli P6's 195/60 R15 86H. Good for at least 20,000 mi. Carol Mutter, 401-849-9036 or 804-587-7264.

1 Shelby gray and 1 Mimilite spoked alloy wheels \$65 ea. or trade for Ronals, or buy Ronals out right. Robert Allen, 114 Kimberly Rd, Hamden, CT 06518, 203-248-8798.

1974 99 parts car, also newer items, cyl. head \$250; '74 trans. \$250; EMS wheels \$50 ea or \$175 set; steel wheels; '78 Turbo doors \$100 ea; rear hatch \$150; eng. & trans. negot. Call or write needs. Dennis Sweeney, 207 E. Church St, Ligoner, PA 15658, 412-238-4556.

99 and 900 WANTEDS

Wanted: hubcap for 1979 900 GLE. Barbara Sweet, 2520 N. Stowell, Milwaukee, WI 53211, 414-964-7175.

Wanted: set of 4 rally wheels for 99. Jim Bowen, 2617 Humboldt Ave S, Minneapolis, MN 55408, 612-333-0077.

Wanted: Two rear headrests for 99 3dr, red or brown. Kenneth Maybury, 2074 18th Ave, San Francisco, CA 94116

Wanted: Good 1.85 fuel injected engine for 1971 \$150? John Jan, Pittsburgh, PA, 412-393-5559, after 7pm & weekends 621-2764.

Wanted: A/C condenser for '79 99 GLE \$50? Parting out complete '73 99. Colin Toline, 122 S. Adams, Hinsdale, IL 60521, 312-323-1943.

Factory Trained N.I.A.S.E. Certified

THE SWEDISH SOLUTION, Inc.

Saab Performance Specialists

27999 Miles Rd.

Chagrin Falls, Ohio 44022

216-248-1022

COMPLETE ORIGINAL PARTS INVENTORY

fuel Injection - Turbo - Suspension

Service Inspections

Guaranteed Low Prices

Same Day U.P.S.



SOLID BRASS KEY TAG

■ SHIPPING INCLUDED
■ CHECK OR MONEY ORDER

ACID-ETCHED ENAMEL LOGO
GIFT-PACKED CAN BE ENGRAVED

Clews & Strawbridge, Dept. K, 310 Lancaster Pike, Frazer, Pa. 19355

VALVE CLATTER

by Jeff Delahorne

EDITORSHIP CHANGES

This will be my last column as Editor of the Newsletter. I have accepted a full-time position with an automotive company that will prevent me from continuing to put out the Newsletter. My wife, Carolanne Curtis, who has taken over an increasing share of publishing the Newsletter in the past couple months, will act as interim editor. We already have a possible replacement editor and we will likely have something firm by the next Newsletter. In the interim, technical questions may have to be referred elsewhere since I will not be available, but all the other business of the Newsletter will hum along as usual.

I must say that I was not really looking for a new job, not to mention moving halfway across the country, but it was a case of an offer that I could not refuse. I will miss getting to talk and correspond with Club members, for the nearly five years I've been here have been most educational for me. And I hope most of you have learned from the Newsletter as well.

FROM THE NEW EDITOR

Jeff's new position takes him to Orange, CT. Until we have a new address there and new editor established, I will continue to publish the newsletter from Duluth. I have a lots of good technical articles for the next newsletters, so if you've sent in a tech tip recently and don't see it here, it's probably typed and ready for the next issue. If you have been contemplating sending in an article, please do not hesitate, the quality of the newsletter has always drawn from the experiences of the Saab Club members.

Carolanne Curtis

HOT START PROBLEM FIXED

For the last 2 years or so, my '76 99GL has been having the same no-start-while-hot problem discussed in the January and April newsletters. I gave my mechanic a copy of Bob Sheflin's fix from January and said "Do this."

Since the fix was installed it has been no problem. The car starts immediately even after extended highway driving in warmer weather. Total cost: about \$10 for a relay and \$20 labor at the local garage. This after a number of more expensive attempted cures got nowhere.

Heartfelt thanks to Bob Sheflin for coming up with a good fix and to you for providing a newsletter that once again has proven worth its weight in gold.

Frank Van Haste, Trumbull, CT

The Club thanks Mr. Daniel L. David, Manager of Technical Services at Saab-Scania of America, and Mr. Robert J. Sinclair, President of Saab-Scania of America, for continuing to provide Saab Service Information bulletins.

Please use knife/letter opener

MAY 1985

86-01 F
Ron Lunder
Box 1174
Westwood CA 96137

FIRST CLASS

RETURN POSTAGE GUARANTEED

c/o Jeff Delaborne
5805 Oneida Street
Duluth, MN 55804



FIRST-CLASS MAIL
U.S. POSTAGE
PAID
PERMIT No. 1909



CLUB ITEMS AVAILABLE

- White Club Coffee Mugs--with blue Club emblem on both sides-----\$5.00 plus \$1.50 UPS
- Club Hats--Light blue baseball hats with Club patch on front-----\$7.00 plus \$1.50 UPS
- Club Patches--embroidered three-color patches, 2-3/4"Hx4-1/4"W-----\$3.00 postpaid
- First Million Book--Saab-Scania published book by Gunnar Sjogren with Saab history and drawings Softcover only-----\$3.00 postpaid
- 1976 Posters--16x20 poster with Mark Stehrenberger drawings of 92, 96, Sonett II, Sonett III and 99 EMS-----\$3.00 plus \$1.50 UPS

BRASS GRILL BADGES BACK IN STOCK

Our new shipment of 1 3/4 x 3" brass cloissone grill badges have arrived. They are \$5.00 ppd.

Haynes Manuals for V4s, 99s and 900s are available from the Saab Club for \$11.00 Third Class Mail, or \$12.00 UPS. Please state model.

Please Note: Shipping costs are per order; i.e. two mugs, UPS, is only \$1.50. Send all orders to: The Saab Club, 5805 Oneida St. Duluth, MN 55804

SAAB



VICTOR

Exclusively since 1958

SALES - SERVICE - PARTS & ACCESSORIES

Wholesale & Retail - UPS Daily Shipments

1125-35 Easton Road, Abington, PA (215) 886-8660