

THE
SAAB
CLUB

COMPACT
FRONTWHEEL
DRIVE CLUB
of AMERICA

JAN. 1980

DEDICATED TO SMALL-
ENGINEED SMALL CARS &
ENERGY CONSERVATION

SAAB Clubs of North America • publisher & treas.: Dick Grossman - 1918 W. Hood- Chicago, Ill. 60660 • phone: 312-743-6742

• Consultants: Rick Sanders, Ruth Grossman, John Fog, Jack Ashcraft, Merle Young.

MEMBERSHIP/SUBSCRIPTION

Newsletter #78 our 61st multipaged monthly. Dues for membership/subscription are \$9.00 for the first year, including two back copies, 12+ tech' sheets and emblem. Renewal dues: \$5.00. Past dues notification will be rubber stamped on the open rectangle at the top of this page. A treasurer's report will be made three times a year. This is a non-profit organization.

Or: a three-ringed binder with at least 18⁺ back copies and 12 tech' sheets is available for \$5.00 postpaid. Or, .20¢ one issue.

Always specify: 96, 97, 99, or 900 and year.

GOLDEN GATE CHAPTER, SAN FRANCISCO, CA.

The Chapter would like ideas from members on what kinds of events they would like to see in the coming months. If you have suggestions about tech' sessions, films, social get togethers, drives to places of interest etc., call Bob Drake at (415)526-1946, Mike Ewell at (408)374-7988 or Rex at (415)282-2161.

Saabers in San Francisco will be happy to hear that Mike Land has opened a garage in SF: Embarcadero Automotive, 210 Brannan St. 546-1384. Michael, lately of Brent Saab in Berkeley, has worked on Saabs for many years and is well known to many Chapter members.

ROCKY MT. SAAB CLUB - The next meeting will be Wednesday, January 23, at 7 P.M., at Deane Buick/Saab, 1080 S. Colorado Bl., Denver, Colo. Carl LePar, one of the most knowledgeable Saab mechanics in Colorado, will be on hand to conduct a Q & A session covering preventive maintenance tips and any technical or trouble-shooting queries you might have. The new line of Saabs for 1980 will be on display for special viewing by members. All meetings open to members and non-members alike. Contact: Barry Nash, for further information: 755-1532.

CHICAGO MEETINGS AT EVANSTON ENVIRONMENTAL CENTER

We signed up this Club as a "organization member" of the Evanston Environmental Assoc. For \$25. this first year fee, entitles us to meet in their hall four times a year. It's on McCormick Blvd., north of Emerson, (Golf) St., southwest of Green Bay Rd., along the channel, admist their arboretum. It has a substantial parking lot and facilities for movie/slides, coffee/butler pantry, etc. We urge southside members to look for a similar center, legion hall, library, etc. This Club will pay a reasonable fee.

Our first meeting will be Tuesday, January 22 at 7P M. Coffee and cakes will be served. At the meeting we will charge \$1.00 per car, plus .50¢ per additional guest.

WESTERN NEW YORK SAAB CLUB - Contact:
David A. Beebe, 28 Elm St., Geneseo, N.Y. 14454

NEW COLLECTION OF MOST ALL PAST ISSUES

Our incoming mail for December was "only" 325, this (and no December issue), gave me enough free time to xerox copy most all tech' articles published in our past issues of 1975 to 1978. As of this writing, Jan. 3, I completed a 19 paged collection of over 40 articles for 96's and Sonetts in one binding. Most articles are organized in accordance to subject matter; exhausts, engines, transmissions, etc. There will be no need for an index, the mailed price is \$1.50. New members with 96-97's who joined in Dec. 1979 and ordered a ring binder will get one of these without extra charge. I am in the process of pasting-up the "99" tech' articles of 1975 to 1978, this collection has 32 pages and will be mailed for \$3.00. There are no editorials, want ads, advertisements, nor "news" articles in these booklets. We recommend that you order one or both of these booklets if you joined our Club in 1979. For those who never ordered our Club binder - the new binder is a good buy for 96, 97 or 99 owners. Only by April 1979 did we begin to print 900 type tech' articles.

PUBLISHERS & TREASURERS' REPORT

December 31, 1979

Our Club bank deposits during 1979 was \$24,427, expenses was about \$22,226 - for printing, permit postage, correspondence postage, equipment, and honorariums. We also received about \$150. in cash. Ruth & Dick Grossman took \$3,100 - total, in pay. No charges for: rent, utilities, transportation, bookkeeping, or editing, artwork or clerical work. The \$3100. is close to what folding and addressing and mailing 29,700 newsletters would cost over eleven mailings at a pro-shop. We also collated and packaged about 700 ring binders and 150 Turbo manual supplements. Our bank balance is \$4,201. A more detailed accounting will be presented to anyone who asks for it. Dick G.

FREE "WINTER MOTORING" BOOKLET

A 16 page booklet has been produced to provide the average motorist with some advice and hints on how to drive a car under slippery conditions.

Copies of this booklet can be obtained, free of charge, through the Public Relations Department at Saab-Scania of America, Inc., Saab Drive, Orange, CT. 06477

Lennart Lonnegren, Public Relations Mgr.

*POPULAR MECHANICS MAGAZINE
PLUGS OUR CLUB*

Page 2.

Thanks to Michael Lamm who wrote a two or three page report on the 900 in the January 1980 P.M.-magazine and was kind enough to recommend the "Midwest Saab Club" - at 1916 W. Hood. I assume the 1916 address instead of 1918 was to help us determine which inquiries we received are from Popular Mechanics readers. We received over 40 inquiries from P.M. during the last half of December and the first week of Jan. We answered all mail promptly in the past 5 weeks.

Criticism of the Lamm survey: Two survey questions asked the 900 owners their opinion of comfort in the front seat and comfort in the back seat? Result: Excellent - 81%, Very good - 16%, Good - 2.5%, Fair - 0.5%, Poor - 0.0% My question: What the heck is the difference between Excellent & very good? Why five rating degrees? Isn't 4 or 3 enough? Of what value is there to ask a new car owner his opinion of the comfort of the rear seat? How can the owner/driver gain two or three hours experience in the rear seat in the first year? Anybody who writes me that he rode in his 900 at the back seat for 2 hours will get a nasty reply, (and a membership in the liars club). Silly questions get silly answers.

ROAD & TRACK MAG - AIRBAGS,

R&T had another hysterical chapter on the horrible airbag installation which has nothing to do with subscribers of R&T. The airbag rule is for 6 passenger-3 in front-bench seat-pigmobiles only. Sports driver-readers of R&T are not pigmobile buffs. The airbags are for dummies who won't wear shoulder/seat belts and are of no concern of sport car/compact car owners. The airbag requirement will help eliminate or reduce pigmobile sales substantially, which is what I want to see.

Along with our \$30. dividend from General Motors, they enclose a stock report and a flyer advertising one of their latest pigmobile models. In the stock report is this gem: "As G.M. looks forward to a strengthening economy in 1980 and a return to normal automotive purchasing patterns, the corporation will continue its aggressive efforts to improve vehicle fuel economy."

Now, how can one improve gas mileage with a return to increased sales of pigmobiles? G.M. executives refuse to change their fat headed concepts.

1980 - 96 SPECIAL IMPORT

To all of you who wrote me, or called, about importing a new Saab 96: Many of you asked the same questions. So far all that I can tell you is this: The list of names has been turned over to a man who is a consultant for Saab in Sweden. He will then show them the list and see if anything can be done about importing some 96's. As soon as he reports back to me I will let you know the outcome.

David Katzakian, 26313 Whitman St. #133, Hayward, California 94544

SAAB KLUBBEN OF STOCKHOLM

Bi-monthly features pictures and pages about the Saab-Lancia 600 a sub-compact, miniature-wheeled-front wheel drive thing closely resembling Rabbits, Omni, Fiesta, LeCar, etc.

TURBO SUPPLEMENT AVAILABLE

We also have plenty of the 43 paged Turbo manual supplements; \$4.00 mailed. The Turbo supplement cost more because we printed only 200 sets as opposed to 500 sets of the 96-97 collection, and about 1,000 sets of 99 booklets.

PERFORMANCE CAR CATALOGS.... This Club has a good supply of Performance Motors, Newport News, VA., catalogs. Write: Saab Club, Box 60272, Chicago IL. 60660, please enclose .54¢ postage.

WINTER MOTORING BOOKLET

is available from Saab-Scania, printed in Sweden in English. Probably available at Saab dealerships. It is well illustrated and contains good advice on snow and icy driving.

DIFFERENT TYPES OF OIL FILTERS

Instead of the Saab oil filter I use either A.C. P.F. 20 or Fram PHF 43. I drive a 1977 99GL with a standard 1985 cc fuel injected engine. They are a lot cheaper and work as well as the original Saab filters. I don't suggest using a cheaper filter since some of them have leaked. Also, I do not notice the oil pressure light being on when starting cold. Benny Lum, Battle Creek, Mich

CLEAN HEADLINERS

A tip for cleaning 99 headliners - Mine was covered with dirt and pipe tobacco stains. Use Woolite Upholstery Cleaner with a soft brush. Blot out the first application when wet to remove the dirt. Then apply again blotting with a clean white T-shirt. Looks like new with no staining. Wayne Nice, New Jersey

THROTTLE ICING -MARGRIT SAYS IT BETTER

Until the throttle housing icing condition can be taken care of by your dealer, Saab urges taking the following precautions when driving in an area where extreme winter conditions prevail:

1. Press the accelerator pedal once prior to starting to be sure throttle operates freely.
2. Avoid driving with a constant level of pressure on the accelerator pedal, particularly at highway speeds during the first half hour after cold start, especially if the car has recently been operated only on short trips.
3. Frequently check for ice build-up in the throttle housing during driving by releasing the accelerator pedal and noting whether or not the vehicle begins to decelerate normally. If the vehicle does not decelerate as expected as a result of the build-up, quick and repeated stabs on the accelerator pedal may temporarily dislodge the ice.
4. As an added precaution allow for the possibility that the distance required to slow or stop the vehicle may be greater than normal should ice become difficult to dislodge readily. If control of the vehicle is so impaired, vehicle crash can occur.

Margrit Adler, Illinois

SAAB SERVICE INFORMATION

RECALL M-45, THROTTLE ICING, M75-79 99 & 900 (EXCEPT TURBOS) - SAFETY-RELATED -NHTSA CAMPAIGN REF. NO. 79V-206 THE CAMPAIGN

Saab-Scania has found that, despite various improvements made during an earlier recall of 1975-76 models and introduced on vehicles built from 1976 onwards, there still exists the possibility that under extreme winter conditions ice can form in the throttle housing and temporarily impede full closure of the throttle plate when the accelerator pedal is released. This is more likely to happen during highway driving if the vehicle has previously been used on several short stop-and-go type trips that did not allow the engine to fully warm up. To eliminate this possibility improved intake air preheating is necessary. (Also, see MARGRIT ADLER-PAGE 3.)

Vehicles Affected by this Recall:

All 1975-79 99 models except 99 Turbo

All 1979 900 models except 900 Turbo

MODIFICATION PARTS

Three kits are available to improve intake air preheating: P/N 9332248-Throttle body water jacket/CVS insulation kit, for all 99*

P/N 9332867-Air preheater improvements/CVS insulation kit, for Federal 900 Two-branch exhaust manifold.

P/N 9332859 -Air preheater improvement/CVS insulation kit, for Lambda 900 Single branch manifold (catalyst-equipped).

* 1975-76 99's with Recall M-02 fix need not have original modification undone. For simplicity kit 9332248 is specified for all 99 variants including 78-79 models with O.E. air preheater.

INSPECTION/REPAIR

99's: Install the throttle body water jacket kit (use free hole punch tool, supplied to make clean holes in air bellows) and CVS hose insulation according to the instruction sheet attached to this S.I. Carefully ensure that there are no coolant leaks.

900's: Replace the intake air preheater parts with the improved ones in the kits and add CVS insulation per the attached instruction.

RECALL CLAIM FORM PROCEDURE

NOTE: Owners notified by Saab-Scania of America Inc. in November, 1979, receive with their notification letter a preprinted M-45 claim form to be used by you. Your dealership will receive the same notice/claim form mailer for each car in your new car inventory and affected cars to be delivered by Saab-Scania of America, Inc. from its depot locations. This form MUST be submitted by the dealer to the Warranty Dept. This is necessary to complete our recall records and update our periodic recall reports to the National Highway Traffic Safety Administration (NHTSA). Records are subject to Federal (NHTSA) audit.

Submission of Recall Claims: The recall claim consists of a Factory copy, a Parts copy, and a dealer copy. Forward only the Factory copy to Saab-Scania of America, Inc., Orange, Connecticut, to the attention of the Warranty Department.

INSTALLATION INSTRUCTIONS

Throttle Housing Water Preheater Kit (P/N9332248)
For 1975-79 Saab 99 (Except Turbo)

KIT CONTENTS

9332255 (1) Water Jacket Preheater, 9332321 (2) Connector Pipe, 8459505 (2) Rubber Sealing Ring, 7970056 (4) Hose Clamps, 9332297 (1) Hose, 7970064 (2) Hose Clamps, 9332305 (1) Hose, 9332313 (1) Hose 79 71864 (1) Strap, 93 29475 (1) Insulating Hose

1. Drain Cooling System.
2. Remove air bellows from throttle housing and air flow sensor.
3. Check throttle shaft, plate, and springs for binding. Correct, if necessary. (See S.I. 05/79-364, Section 2 Page 92.) Clean throttle housing with a suitable solvent (one that leaves no film or residue such as carburetor cleaner or Loctite Kleen 'N Prime) to the depth that the preheater will enter. Also clean the preheater housing.

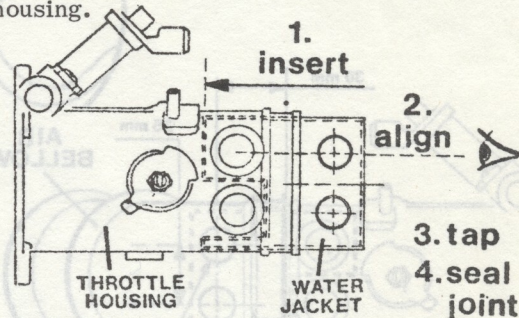

4. Place the water jacket preheater in the throttle housing and align the openings with the CVS and auxiliary air nipples. Use a PLASTIC MALLET and tap the preheater firmly into the throttle housing.
5. Flow Loctite 290 (Wick 'N Lock) around the joint. (Wick 'N Lock will function exactly the same as sweat soldering of a copper water pipe.) NOTE: Allow Wick 'N Lock to set up while performing the following steps and before reinstalling the air bellows.
6. Disconnect the forked water hose at the water pump and the upper heater connection.
7. Connect the shorter 8mm I.D. hose (485mm long) supplied in the kit to the water pump connection of the forked hose. Use one stepped connector and one large and one small clamp from the kit. Install clamps so that the worm screw locks point down. Lead the newly connected hose under the inlet manifold to the throttle housing heater. (Do not connect at this time.)
8. Reassemble the forked hose to the upper connection of the car heater.
9. Assemble the long water hose (720mm) from the kit to the short thicker hose (also provided in kit) using the remaining step connector and two clamps.
10. Attach the assembled hose to the water pump cover connection. Route the free end of the hose over the inlet manifold and down through the center opening in the manifold runners, under the front runners, and forward to the throttle housing heater. (Do not connect to heater at this time.)
11. Mark the locations on the air bellows and use a 5/16" punch to punch out the holes. (See sketch provided for proper locations of holes.)

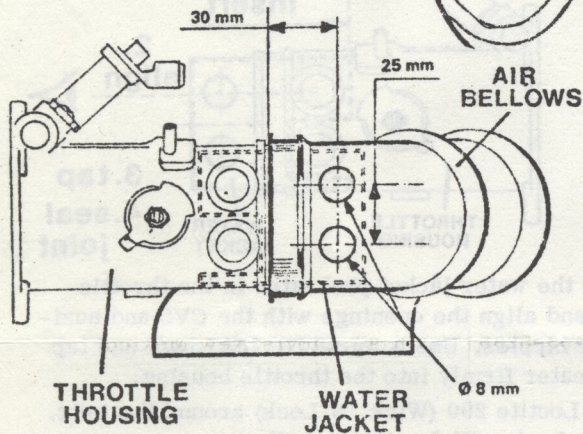
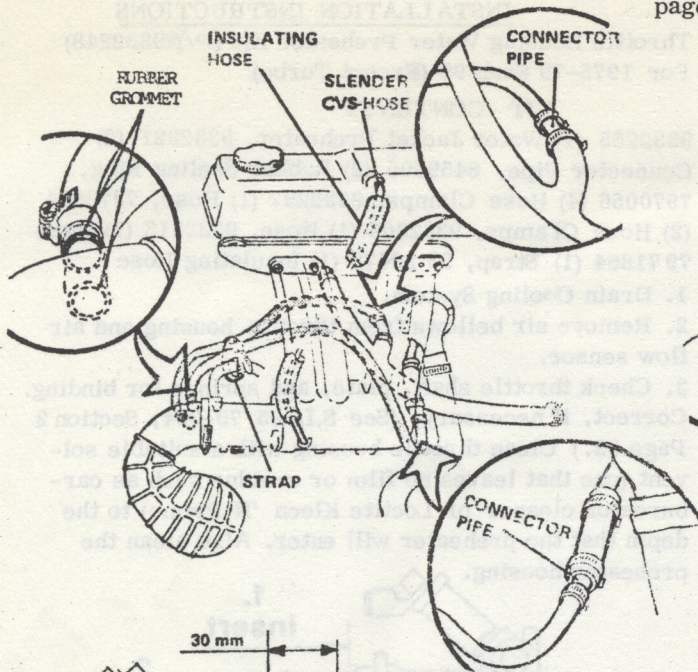

12. Install the air bellows. (NOTE: Use of silicone spray inside the bellows and the holes for the preheater connections will ease the mounting process.) Be careful not to loosen the preheater when installing the bellows.

13. Place the two rubber o-rings from the kit on the water nipples of the preheater and press them against the air bellows.

14. Attach the water hoses to the nipples. (Use the remaining two clamps from the kit.) Press the hoses tight to the o-rings (squeezing them against the bellows) and tighten clamps.

15. Use the Nylock tie provided to secure the two water hoses and the CVS and air bypass hoses into a neat package alongside the throttle housing. Be sure the water hoses are not kinked at any point.

16. On 1976 and later cars thread the thick insulating hose from the kit over the small CVS hose as shown in the sketch. Gently tie each end of this hose snug to prevent entry of outside air. (A Nylock tie strap works well for this purpose.) On early cars equipped only with a large diameter CVS hose, slit the insulating hose, install and tape it in place.

17. Replace coolant, run engine until warm, and top up cooling system as extra coolant is required. Check that system is leak free.

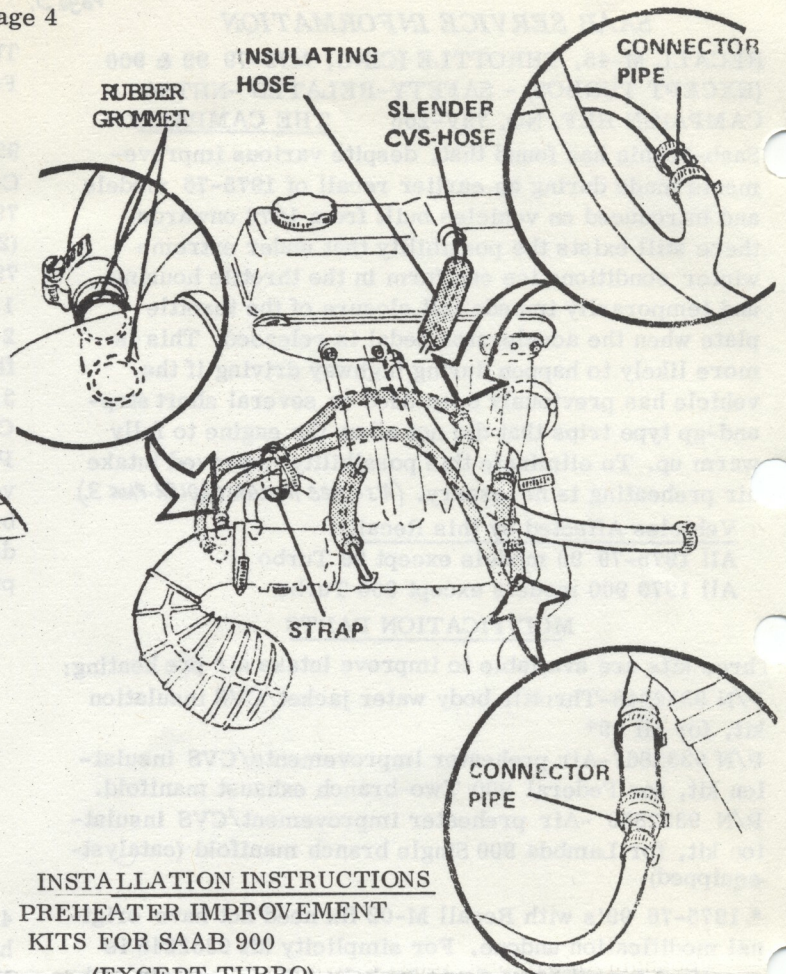

**INSTALLATION INSTRUCTIONS
PREHEATER IMPROVEMENT
KITS FOR SAAB 900
(EXCEPT TURBO)**

A. P/N 9332867, FEDERAL 900 (Two-branch exhaust manifold)

1. Remove the two front bolts of the manifold preheater stove and install the baffle, provided in the kit, at the bottom front of the manifold.
2. Replace the thermostatically controlled air intake valve (on the air cleaner) with the one provided in the kit.
3. Replace the preheater hose with the insulated hose from the kit.
4. Replace the CVS hose nipple in the intake manifold with the one provided in the kit.
5. Place the insulating hose over the CVS hose, gently tie the end closed over the CVS hose and reinstall the now insulated CVS hose assembly.

B. P/N 9332859, LAMBDA 900 (Single-branch manifold)

1. Replace the existing preheater stove with the modified type from the kit.
2. Replace the thermostatically controlled air intake valve (on the air cleaner) with the one provided in the kit.
3. Replace the preheater hose with the insulated hose from the kit.
4. Replace the CVS hose nipple in the intake manifold with the one provided in the kit.
5. Place the insulating hose over the CVS hose, gently tie the end closed over the CVS hose, and reinstall the now insulated CVS hose assembly.

SA
CLU
JA
198

SAAB CLUB DEALER/MECHANIC LIST

This is a list of "Recommended" Dealers & Mechanical Shops. The list contains the OLDEST - most experienced dealers, ten years or more. It also has dealers and shops recommended by some of our members. We do **not** have personal experience with most of them. These service shops are not low priced, that is not the criteria. Ability, competence, and reasonable sincerity is.

You must not assume that these shops will work fast and cheap. Nor, should you expect them to honor your idea of free warranty work. No matter what, the MECHANIC MUST BE PAID WELL for good work done, he did not make the car and he did not sell it. So, tip him when you can. A good dealership should have at least two or three SAAB specialists, they should have more mechanics than salesmen.

(List revised December 17, 1979)

WEST COAST

Pioneer Automotive, 1733 Dowling Anchorage, Alaska 99503
Sunshine R.E.A. Fairbanks, Alaska
 Al Roberts, Hi-Performance Spts. Car Tech' Serv. 848 Ilaniwai St. Honolulu, Hawaii 533-4984
Vasek Polak, 199 Pacific Coast Hwy. Hermosa Beach, CA. 213-376-0935
 Command Performance, 8575 Commerce St., San Diego, CA. 714-566-4230
Johnston Racing, 8656 Comm., San Diego, CA. 714-578-1348
 *Mike Ewell at: Carlsen's Calif.
Vreeland Cadillac, 6450 Leland, Ventura, Calif. 642-6711
Paradise Mt'rs. 5804 Paradise Dr. Corte Madera, Calif. 415-924-6123
 Tor's Foreign Car Serv. 414 N. 'H' St. Lompoc, Calif. 736-5368
Scandia Auto Imp'ts, 14021 E. Whittier Bl., Whittier, Calif. 698-0547
 SSS (Specialized Saab Serv.) Berkeley, Calif.
West Coast Spts. & Impt's, 4761 Convoy, San Diego, Calif. 279-4462
 Borrdini Racing (96's) 898 Mission San Luis Obispo, Calif. 541-0189
Svensk Motorsport, 5335 Banks St. San Diego, Calif. 92110
Saab-Saver, 2145-35th Ave. Oakland, Calif.
Star-Lincoln-Saab, 901 S. Brand Bl., Glendale, Calif. 247-1903
John's Imported Car Serv. Santa Barbara, Calif.
 Michael Land at: Brent's
B&B Foreign Car Center, 2983 ElCamino Real, Santa Clara, CA.
Euromotor, 1902 LaFayette, Santa Clara, Calif. 95050
German Car Clinic
 430 S. Bascom, San Jose, Calif.
Parker Automtve, Arco Stat., San Antonio & Middlefield Rds., Mt. View, CA. 415-494-6904
Sepulveda Saab, Sepulveda, CA.
Swedish American Mtr'port, 1635 Ohms Way, Costa Mesa, CA. 714-548-0412

Peninsula VW, SAAB, San Mateo, CA.
Ken Blamires, Import Mtr. Works 1651 N. Serrano, Hollywood, CA. 213-463-3412
ABCO Electric, 3330 20th St. San Francisco, CA. Alternator repair
Ace Muffler, Long Beach, CA. 213-599-1920
Eldon Penner, Santa Rosa, CA. 707-525-1635 -Trans' rebuilds
Lindqvist Mtrs., 4235 S. Sepulveda Culver City, CA. 213-390-3652
Jim's Upholstry Shop, 15608 E. 14th, San Leandro, CA.
Johnston Racing, 5385 Overland San Diego, CA. 1-714-565-2783
Trans' overhauls
Jim Haskins, 2635-B 25th St. San Monica (2 stroke, V4) 213-396-0586
John Clements, 1050 Fiske St. Pacific Palisades, CA. 213-459-5235
Rebuilds Trans'
Perry & Key, 28953 Mission Bl. Hayward, CA. 415-537-1175
John Bus/Scandia Imports
Whitter, CA. 714-970-6908
Huling Buick, 2200 W. 7th, Eugene Oregon 503-686-2424
Coach & Four, 1019 N.E. Everett Portland, Oregon 224-1768
Alex Fowler, Circle & Square Mtrs. Port Townsend, WA.
International Car Center 21420 Hwy 99, Edmonds, Wash. 775-1921
Eldon Vories Mt'rs. 207 S. 9th St. Walla Walla, Wash. 529-4450

WEST

Garff Mtr. Center, 600 So. & State Salt Lake City, Utah
Cline's Auto Sales, 4608 S. State St. Murray, Utah 266-3548
Hanson Equip. Inc., Hwy 6 & 50 Grand Junction, Colo. 243-7771
Boulder Valley VW, 3150 28th St. Boulder, Colo. 444-1644
Deane Buick-Saab, 1080 S. Colo. Bl., Denver, Colo. 80222
'Mel' -Markleys Imports, Greeley, Colo.

Karl's Saab Clinic, Near airport, Denver, Colo.
Eric Killinger, 412 Peterson, Ft. Collins, Colo. 303-493-4595
Charles Towner - Saab
425 W. Fillmore, Colo. Sprgs, Colo.
Carpenter Mtrs, 211 Pearl, Boulder, Colo.
Steve Kelley, 49th & Pearl Boulder, Ft. Collins Foreign Car, 205 N. College, Ft. Collins, Colo. 80521
Dana Motors, 2046 Grand Ave. Billings, Montana 656-7654
Little German Inc., 3940 E. Speedway Bl., Tucson, Ariz.
Valley Imports, 1433 E. Camelback Rd., Phoenix, Ariz. 85014
602-279-4433
Gary's Foreign Car Serv., 1810 W. 7th St., Clovis, New Mexico
Import Auto Repair, Las Vegas, Nev.
Kevin Crawford, Frontage Rd. 190 Kellog, Idaho
Fred Parker, Chaffin Olds, Idaho Falls, Idaho
Bruce Peterson, Honda/Saab
3600 Reserve St., Missoula, Mt. 406-711-4900

SOUTHWEST

Holley's, 308 Colorado, Austin, Texas 478-8620
Rollins Mt'rs., 2111 Wyoming St. El Paso, Texas 533-7411
Alpha Auto Supply, G. Callow, 1920 Trinity Mills, Carrollton, Tx.
Jack's Complete Car Care, 706 Montana, So. Houston, Texas
Herring Auto, 1403 Forest Ln., Garland, TX. 276-5141 (Dallas)
Star Mtr., 7000 Katy Rd., Houston, TX. 713-869-8511
Pit Shop, 326 Butternut, Abilene, Texas
Charles on Maybell, off IH-35, near Weidner, San Antonio, Tx.
French's Foreign Car Serv., 940 N. Bolt Line Road, Irving, Tex.
Smitty's Auto Shop, Austin, Tex. Spec. in 96 & 97

MIDWEST

Auto Sports Int'l, 1000 N. Cliff,
Sioux Falls, S.D. - Jamie Hogan
Deadwood Mt'rs Sales, 155-7
Sherman, Deadwood, S.D. 578-1450

Bob Adams Impts., 2004 E. Main
Albert Lea, Minn. 56007

Bruce Clark, 1900 W. Wayzata Bl.
Long Lake, MN. 612-473-5525

Tom Stendahl, Phoenix Mt'rs. 701
Hwy. 7, Excelsior, MN.

Phil Schockley, 2605 County Rd. H.
Minneapolis, MN. 612-784-5432

John Youngdahl, Shade Tree Gar-
age, White Bear Lake, MN.

Schoon Mtr. Sales, 201 S. Cedar,
Luverne, MN. 507-283-2378

Odberg & Ryan, 2224 W. Superior
Duluth, MN. 722-3317

Rod Baxter Imports, 857 Grand
Ave. St. Paul, MN. 227-9351

*Morrie's Imp'ts, 12520 Wayzata
*Bl., Minnetonka, MN. 612-544-0376

Irv Johnson, Highland Serv. Center
Duluth, MN. 55806

Suburban Mt'rs. of Grafton, Hwy.
57, Grafton, Wis. 414-377-1000

Don Holcomb, Baraboo, WI., Reeds-
burg Rd. & US 12 & Co. 'A' After 6
PM - 356-7565 or 356-8986

Import Auto Clinic, 2583 Univ. Ave.
Madison, WI. 608-231-1221 or 3418

Rallye Imports, 6817 W. North Av.
Wauwatosa, Wi. 414-475-5500

MICHIGAN

Mike Blanchard, Shell Brookfield
Station, Grand Ave., E. Lansing, MI.

Overseas Imports, Ann Arbor, MI.

David Parps, 1306 E. Alcott,
Kalamazoo, Mich.

Overseas Automotive, 5801 Dixie
Hwy., Saginaw, MI. 48601

Trans World Automotive, 2001 Page
Ave., Jackson, Michigan

Simmons Ford, 402 W. Prairie St
Vicksburg, Mich. 616-649-1022

Trio Mt'rs., G 3367 Richfield Rd.
Flint, Mich. 313-742-7792

Steward-Heriman, 830 28th St. SE
Grand Rapids, Mich. 452-6916

B. Beouvais/Pit Stop, Grand Rpd.,
Mich. 616-538-7600

K & N Sunoco, 3005 Packard, Ann
Arbor, MI. 48104 313-973-2929

Imported Car Center, 912 Saga-
more Pkwy., N. Lafayette, Ind.

* Gibson Mtr. Co., Main & Jackson
Perrysville, Ind. ***

ILLINOIS

* Peterson Automotive (Jon), 1445
Oakton, Des Plaines, Ill. 312-299-
7153

Bob's Auto Repair, Jefferson and
Evergreen, Bensenville, Ill.

* Europa Mt'rs., 2414 West Rte. **
120, McHenry, Ill. 815-385-0700

Flikkema Mt'rs., 2424 E. 176th
Lansing, Ill. 312-474-1933

Metric Wrench, 2501 1/2 N. Grand
Springfield, Ill. 217-789-4576

Mr. Auto Body, 1405 Hagan,
Champaign, Ill. 217-352-8585

Fiberglass Shop

Bob Sanderson, Alpha Beta Works
Kesslinger & Randall Rds., Geneva
Ill. 312-232-2624

(Joe) D.J. Rosauer, Cedar Falls,
Iowa

Meyer Garage, Main St., McIntire,
Iowa 515-737-2239

OHIO

The Common Market, 500 W.
Broad, Columbus, Ohio

Import Mtrs., Painsville, Ohio
216-354-5689

Geo. DiFeo-Elite Mtrs., 2600 Whip-
ple, NW, North Canton, Ohio

Terry Wells, 15141 National Rd.
SW, Reynoldsburg, Ohio

Ed Wolf Shaker Saab, 10299 Shaker
Bl., Cleveland, Ohio 216-231-2722

Saab Columbus, 1562 King Ave.
Columbus, Ohio 614-486-6731

Roger Karns, Precision Automt've
S.R. 235 & Gerlaugh Rd., New Car-
lisle, Ohio 879-1127

Swedish Cars of Cleveland, 280
Broadway, Bedford, Ohio 439-1280

Tom Duncan, International Auto
Sport, Merriam, Kansas

Overseas Auto Serv., Pattie St.
Wichita, Kans. 67202

Spisgardt's Automotive, 8209 Man-
chester, St. Louis, MO. 314-968-2585

Hall Howard, RFD #4, Warrens-
burg, MO. 64093

Rolf Phillips 66, Midland Ave.
University City, MO. 63130

George's Imports, 7746 Worvall
Rd., Kansas City, MO. 64114

PENNSYLVANIA

Bane Auto Service, 500 32nd St.
Altoona, PA.

Bill Grabe, Rte. 8, South of But-
ler, PA. 282-1341

Stillman's Auto Ctr., 45 S. Mac-
dale Bl., Glenolden, PA. 583-1771

Kunkie Mt'rs., R.D.#1, Dallas,
PA. 717-675-1546

* Gingrich's Saab, 110 State St. *
W. Fairview, PA.

Al Tilley, 76 Grow Ave., Montrose
PA. 717-278-1103

Clews & Strawbridge, 310 Lancast-
er Pike, Frazer, PA. 215-644-5054

Richie's Auto Serv., 14240 Rte. 30
N. Huntingdon, PA. 412-823-3970

Guy McCardle, 100 S. Logan Bl.
Burnham, PA. 17009

Kehler & Field Saab, U.S. Rte. 15
Mansfield, PA.

Albert Sefcik, Country Mtrs. 620
Evans City Rd., Butler, PA.

Victor Sports Cars, 1135 Easton
Roslyn, PA. 215-886-8660

Werner Mt'rs., 1250 N. Broad St.
Lansdale, PA. 215-855-9077

Beck Foreign Cars, Rte. 616 York
New Salem, PA. 717-792-1510

DeFinizio Impts, Rte 420-291
Essington, PA. 215-521-9200

MB Serv. Center, 129 N. MacDade
Bl., Glenolden, PA. 215-583-0322

Dick's Speed Shop, 2542 Pennsylv.
Hagerstown, MD.

Ken Mead, 371 W. Patrick St.
Frederick, MD. 301-662-5100

Scand' Imp. Serv. Ctr., 7404 A
Westmore Rd., Rockville, MD.
340-722

Brewer's Auto Repair, Main St.
Maugansville, MD. 301-739-0420

* W.A. Koopman, 4922 Cordell Ave.
Bethesda, MD. 301-656-9220

Wayne's Auto Repair, Gety Serv.
Sta., 6100 Reisterstown Rd.,
Baltimore, MD. 358-5300

Danneman's Auto Serv., 223 Little
Montgomery St., Laurel, MD.
301-725-2244

Svenska Imports, York Rd., North
of Mt. Carmel Rd., Hereford, MD.

Dean Hill, Claremont, N.H., Charleston Rd., PO Box 657
603-543-3127

NEW YORK

Norm & Vinny, Glen Cove Imp'ts
Glen Cove, New York

Huntington Gulf, 445 W. Jericho
Tpke. & Oakwood Rd., Huntington,
N.Y. 271-1661

Cedar Grove Mt'rs., Long Island N.Y.

Fred Carl, New Salem, N.Y.
South of Albany

Drake Mtrs., Rte. 262, Box 268
Elba, N.Y. 716-757-2523

Europe Garage, RD #1, Cortland
N.Y. 607-756-2866

Lighthouse Mt'rs., Danbury Rd.
Rte. 6, Brewster, N.Y. 2798066

Bel-Aire Mt'rs., 421 Richmond
Staten Island, N.Y. 212-981-2353

Wallace Scott, 557 N. State Rd. Briar-
cliff Manor, N.Y. 914-941-8660

Checkpoint Foreign Car Serv. 487
Kenmore, Buffalo, N.Y. 836-2033.

Setauket Foreign Mtr. Main St. Rte.
25A, E. Setauket, N.Y. 941-4540

Louie's Garage, Rte. 1, Waddington
N.Y. 315-322-5535

Sports Car Centre Ltd., Syracuse, N.Y.

New Salem Garage, RD1, Voorhees
ville, N.Y. 518-765-2702

A.L. Sibley, 520 Rock City St.,
Little Valley, N.Y. 716-938-2441

Luv Imp'ts., Ltd. 220 Fulton St.
Farmingdale, N.Y. 694-2200

Brownell Mt'rs., Rte 52, Fishkill,
N.Y. 914-831-3000

Dave's Foreign Car Serv., St. James
Long Island, N.Y.

Coldspring Imp'ts, 800 W. Jericho
Tpke, Huntington, N.Y. 692-6465

L.I.C. Imp'ts., 21-01 43rd Ave.
Long Island, N.Y. St4-8888

Zumbach Sports Mt'rs., 11th & E.
55St., New York, N.Y. 247-1444

Brown Bear Automotive, 8 Bridge
St., Florida, N.Y. 10921

NEW ENGLAND

Clyde Billing, 259 Riverside Dr.
Augusta, Maine 207-622-6336

Stetson Auto Sales, Rte. 131, P.O.
Box 3, Warren, Maine 273-2345

Knight Auto Sales, 54 Cumberland
Bangor, Maine 207-942-1505

Coldbrook Saab, Upper Madison
Av., Skowhegan, Maine 474-9881

Ocean View Foreign Cars, Rte. 9
Cape Porpoise, Maine

Caribou Dodge, 208 Main, Caribou
Maine, 207-493-3367

Barry Glynn Foreign Autowrks
R1, By-Pass, South, Kittery, Maine

P.J.'s Auto Village, So. Burling-
ton, VT.

Ed S. Fleury, P.O. Box 205
Essex Center, VT.

A&B Mt'rs., 25 South St. Wood-
stock, VT. 802-457-2444

Vinton Mt'rs., RFD 4, Memorial
Dr., St. Johnsbury, VT. 748-3169

Tofani Mt'rs., Rte. 2E. Mont-
pelier, VT. 802-223-6396

Wigwam Spt. Car Ctr., 1385 Miner-
al Sprgs., N. Providence R.I.

Charlie Newkirk, Auto Emporium
Derry, New Hampshire

Olin's Garage, Tilton-Franklin Rd.
Franklin, N.H.

Blake Auto Saab, Exeter, N.H.

Dick Kinney Auto Sales, 149 Am-
herst, Nashua, N.H. 883-5713

128 Sales Inc., 230 John St. Box
487, Reading, Mass. 944-7760

Paul Murphy, Best Buick, Saab
Haverhill, MA

Gauthier Mt'rs. 142 Canal St.
Salem, MA. 617-745-5500

* Mecca Mtrs. 30 Penniman rd,
Allston, Mass. 617-787-1707

* Hillcrest Auto Inc., 20 Janes Ave.
Medfield, MA. 617-444-0441

F. M. Shaw, 427 Lincoln St. Hing-
ham, MA. 617-749-1617

Gene's Garage, 265-69 Lowell St.
Lawrence, MA. 617-682-7047

Import Mtr. Sales, 346 Electric
Lunenburg, MA. 617-342-3425

G. Andrey of Framingham, 1800
Worcester, Framingham, MA.
617-875-0639

Gaston Andrey Assoc., 20 Water-
town, Watertown, MA. 923-9230

Bedard Bros. Rte. 8, Cheshire,
MA. 413-743-0014

Dan Chernoble-Overseas Mt'rs.
28 Pratt, Allston, MA.

Gaston Andrey of Boston, 5 Waldo
Brookline, MA. 617-734-5280

Ron Young, RK Automotive, 3 Broad-
way, Westford, MA. 692-7058

Nick Toomey
Ware, MA. 1-617-867-9262

Paul Murphy, Acton Foreign Auto
4 Eastern Rd., Acton, MA. 263-0775

C. Eric Nelson, Pioneer Valley
Greenfld, Rd., Deerfield, MA.
413-665-2140

Secors Saab, Broad St., New Lon-
don, CT.

Nelson Mt'rs., 400 Boston Post Rd.
Old Saybrook, CT. 203-388-5785

Mitchell Pontiac, 384 Hop Mead-
ow St., Simsbury, CT. 658-4431

Continental Mt'rs., 15 Station Pl.
Stamford, CT. 203-327-7410

Hoffman Motors, N. Windham, CT.
Saab of New Cannan, New Cannan,
Conn.

Continental Motors, Fairfield, CT
Steve Graseck, Farmington Mtr.
Spt. Serv., Farmington, CT.
203-677-9074

West Haven Mt'rs., 221 Bull Hill
Ln., West Haven, CT. 934-6311

Sports Car Serv., J. Jacobson
Wilmington, Delaware

How-Lou Mtrs. Rte 36
Keansburg, New Jersey

Reinertsen Mt'rs., Rte. 53, Den-
ville, N.J. 201-627-0616

Parkfield Mt'rs., 18 New Bridge
Rd., Bergenfield, N.J. 385-7736

Rotchford Pontiac, 433 North Ave.
E., Westfield, N.J. 232-3700

Middlesex Foreign Car Serv., 1233
Rte. 27, Somerset, N.J.

Swartz Mt'rs., 200 E. Blackwell
Dover, N.J. 201-366-0224

British & European Car Serv.
Louisville, KY. 40201

Phil Morton, Cont'l Car Inc. 1925
Union, Memphis, Tenn. 274-9041

Smith Impt. Car Serv., 1250 E.
Broadway, Louisville, KY. 583-4724

Ole Volks Home, Hwy. 45 North
Humboldt, TN. 784-4936

Joseph Sterbutzel, P.O. Box 196
Moorefield, W. VA. 26836

Lester Mt'rs. 6352 Virginia Beach
Bl., Norfolk, VA. 23502

Dominick Mtr. Co. Rte. 250E.
Charlottesville, VA. 295-3131

BSR Impt. Inc., 315 W. Main St.
Charlottesville, VA. 22901
804-977-6760

*Ted Tucker & Loki, Rte. 1, Box
198, Earlsyville, VA. 22968

Bibb Svenska Imp'ts., 9518 Jeff
Davis Hwy. 804-275-6991
Richmond, VA.

Crypto Mt'rs., 901 N. Glebe Rd.
Arlington, VA. -Jim Springer

*John Poulton-STs, Ltd., Rte 7,
Box 78, Durham, N.C. 27707

Grose's Corner, 1105 Spartanburg
Hwy., Hendersonville, N.C.

'Doc' - Eastside Auto Clinic, Char-
lotte, N.C.

Gene Jones, America Imp. Serv.
Battleground Av., Greensboro, N.C.
Morris Mt'rs., 2038 Meeting St.
Charleston Hgts., S.C. 554-4455

Complete Saab Sales, Hwy 92-Box
217, Woodstock, GA. 926-2428

Savannah Int'l Mt'rs., 8301 White
Bluff Rd., Savannah, GA. 352-4741

Mike Harrison, NE Imp'ts Serv.
Bldg. 34B, DeKalb-Peachtree Air-
port, Chamblee, GA. 404-451-8895

Jim Whitstruck, 6001 Nashville
Pensocola, Florida

Checkpoint Inc., 1715 S. Missouri
Largo, Florida 813-581-3527

Tom Denton, Geneva, Fla.
305-349-5571

C.H. James/Bob Brown Impts. 4902
S. Orange, Orlando, Fla. 857-3620

J. James, 4936 S. Orange Ave.
Orlando, Fla. 851-4320

Quentin Hall, Beach Blvd. Automtve
Jacksonville, Fla.

Cartech, 1681 SW 67th, Miami, Fl.

Phil Crist, Impt. Serv. Center
Gainesville, Florida

Holmes VW, 5295 I-55 North
Jackson, Miss. 601-362-9616

CANADA

* Harry Holvajian, Marino's 3480 *
Lakeshore Bl., W. Toronto, Ont.

Ninth Ave. Mt'rs., 895 St. Louis
Lachine, Quebec

Centaur Import Mt'rs., 3819 Mac-
leod Trl., SW, Calgary, Alberta

Raymond's Auto Centre, Pt. Arthur
Thunder Bay, Sptehen & N. Cumber-
land St., Ont. 345-0561 or 8353

Otto's Service Centre, 245 Rich-
mond Rd., Ottawa 613-725-3048

Nino, Sunoco Garage, Laurence
& Marlee, Toronto

Grand Touring Cars, Barry Nunn
744 York St., London, Ont.
433-3232

Peter Stojanovic, 5 Robert, Tor-
onto 416-924-8219

PARTS SOURCES

Anderson Engineering, Epsom, N.H.
Auburn sp'k plug, pointless ign'.

Restoration & Maint'nce, Box 585A
Rte. 2, Golden, Colo. 80401-Two
stroke catalog 50¢. R. Steinway

*Performance Cars, 9916 Jefferson
Newport News, Virg. 23605-2 stroke
& 99 acc'sories. 804-596-3700

Eriksson Automotive & Machine
Branford, CT. 203-481-3057
Rebuilt trans' & engines

Hoosier Int'l (Arnolt) P.O. Box 595
Warsaw, Ind. 46580. Carbs, etc.
Ask for proper catalog.

Mile-Hi Body Shop, Santa Fe Bl.
Denver, Colo.

Repcoparts USA, Inc., 13921 Bett-
encourt St. Cerritos, CA. 90701
926-6582. Ask for proper catalog
eng., carb'tr, etc. \$2.

Motor Sport Serv., 1400 E. Second
St., Jamestown, N.Y. 14701.
steel mufflers, etc.

Ed Iskenderian Racing Cams,
16020 S. Broadway, Cardena, CA.
90248

Power House Ford engines. 3013
Enterprise St., Costa Mesa, CA.
92126. FOMOCO V4 dealer.

Dave Baugher, 5511 - 63rd Ave.
Riverdale, Maryland (301) 779-
6554. 3 Cylinder & Cranks rebuilt

SUGGESTIONS FOR THE NEW SAAB OWNER

The Saab 99 is not the best car on
the market, the "best" car would
cost about \$90,000 or rather you
would have to purchase a package
of 3 or 4 vehicles to possess some-
thing that answered to all criteria:
the most economically operating
car, the most durable, the most
maneuverable, the fastest, the
safest, and the lowest priced...

It is impossible to build such a car
yet among the 5,000 letters that we
have received from our members,
we have encountered a few that
expected these six (and more) →

features in the Saab.

The Saab is a production car—and
all production cars must compete
with Detroit—who produces cars
at the rate of one-a-minute (using
several production lines and teams).

At the Rolls-Royce plant, one man
works two days on one door. Their
prices in early 1976 was between
\$30,000 to \$90,000.

Our point is—if you want a perfect
Saab with no defects you'll have to
pay twice \$1000. Furthermore,
all talk about the dealer's responsi-
bility to correct defects upon de-
livery is nonsense. Very few deal-
ers do the work on the car—the
mechanic back in the shop is as-
signed the job. Very few dealers
and their mechanics have an en-
gineering degree, and all talk
about what the dealer should do is
pure drivel.

You can shout and scream, and
Congress can pass laws, but, we
won't make great engineers out
of dealers. If a dealer and his
mechanic does innovate a solution
to a mechanical defect they should
charge a lot more than \$20. per
hour. Defects are not the fault of
the dealer's mechanic, he did not
make the car, he did not sell the
car, nor make any commissions
on it.

So, that is why we urge you to in-
spect the car yourself.

Don't waste time inspecting the
painted surface & conditon of the
upholstery. Hagglng over trivial
scratches takes away work on the
important mechanical things.

Test for loose bolts at manifold
to muffler connection. Motor -
mounts. Look to see if the water
drain tubes are clear, & the rubber
plugs are in place, *or removed*.
Check if Air/cond' pump pulleys are
square-inline, & the tubes are tight.
Tip the mechanic, ask him to take
his time on your car.

This writer does not believe in
"warrantees", Only a skilled
mechanic can fix a problem - not
that piece of paper or a white col-
lar Co. rep' or the executive deal-
dealer. NEVER write me about
the warrantee, (Dick Grossman).

CLASSIFIED ADS RATES

Ads offering parts or Saabs for sale or wanted, at prices under \$200., are FREE to members and non-members. 25 word limit, plus name and address.

Ads listing \$201. to \$900. enclose: \$2.00. Ad listing: \$901. to \$2,000. enclose: \$5.00. \$2,001 & up: \$10., per 25 words, no charge for name & address.

We will delete superlatives, abbreviate where possible. Do not count 2 letter words. All ads without a price must enclose: \$10. check.

(Each Newsletter page cost over \$100. to produce and mail).

Page 9.

FOR SALE: 1974 Sonett III, AM/FM, seats reupholstr., Mtr. Sports exhaust, runs good, driven daily, needs some body work; \$2000. WANTED: For 1973 99, (1) hub cap; \$5.?, (2) head rest cushions; \$15.-\$20. pair. Dave Booher, Box 457, Belle Center, Ohio 43310 (513)464-3023

FOR SALE: Sonett III, new 1975, 18,000 mi., in storage 2 years, green, a/c, Am/FM. New: Diehard, 5 2X Mich'; \$4000. Also trailer; \$400. Both for \$4200. Also: clutch-pressure plate; \$20. (305) 268-0926 Ernest MacQuaters, Box 114, Scottsmoor, Fl. 32775

FOR SALE: 1968 Sonett II, 50,000 mi., engine OK., chassis rebuilt, body good, cracked rear glass. New: Michelins, shocks, & battery. \$1,000. Or trade. Jeff Elghanayan, 309 E. 45th St. New York, N.Y. 10017

FOR SALE: 1971 Sonett, mechanically sound. \$2000. Serious inquiries only. (201)786-6054 J. Fournier, 155 Deer Run, RD3, Andover, N.J. 07821

FOR SALE: 196? SAAB Quantum III. Prototype open sportscar. Possibly only one left. Monte Carlo engine. Blue & Yellow Swedish colors. Recently restored. Must sell. \$8,000/or offer. (213)384-9321 (work) or (213)783-4823 (home) Rob Kleban, 15731 Addison St., Encino, CA. 91436

FOR SALE: 1968 Sonett II -V4. Completely disassembled, started to rebuild, ran out of time. Have all parts, \$900./best offer. (201)583-1764 Zip: 08879 Dan Frutiger, 73 Lantana Way, Laurence Harbor, N.J.

FOR SALE: 1971 Sonett III, 51,000 mi., good mech./body, but needs minor work. \$2200. Also have 1972 Sonett parts car. (516)421-5277 Bob Bondurant, Huntington, N.Y.

FOR SALE: Rocker panel (right side) for Sonett II P/N 7416936 - brand new. \$35. plus shipping. Tim Siebold, Main St., West Haven, CT. 06516 (203)932-2116

FOR SALE: 1967 V4 95 wagon, rustfree, 45,000 mi. (original). Many new parts, good overall cond. \$900. Eves. & wkends. (203) 329-7124 Carl Stewart, 415 Farms Rd., Greenwich, CT. 06830

FOR SALE: 1970 V-4 white station wagon, no rust, 10,000 mi. on rebilt eng. & trans. 28-30 mpg. Dual copper exh. system, roof rack, trl. hitch, many extras \$1995. Eves: 1-217-435-3084 Ken Wyle, 251 W. State St., Waverly, Il. 62692

FOR SALE: 1972 96 V-4. New clutch, pressure plate, 2 new tires. AM/FM cassette, rebuilt starter & radiator. Body & interior good mechanically. \$2500. Gene Beban, 1025 -25th St. #2, San Pedro, Calif. 90731 (213)547-5840

FOR SALE: 1960 93, good body, running condition. Many extra parts included. \$350. (201)226-7256 John Parsekian, 45 Espy Rd., Caldwell, N.J. 07006

FOR SALE: 1972 95 parts car. Green, 62,000 miles, needs fan gears: \$400./best offer. (414)873-2973 Don Littmann, 3009 N. 53rd St., Milwaukee, WI. 53210

FOR SALE: FoMoCo V-4 carb w/spacer plate and deceleration valve, used 15,000 after rebuild; \$35. Intake manifold; \$40. Plus shipping. (213)477-9869 Ed Steele, 1517 Federal #4, L.A., CA. 90025

FOR SALE: (4) Bilstein gas shocks from '78 EMS, used 9,000 mi. \$125. set includes shipping. J. Hansen, 1049 Green Bay Rd., Lake Bluff, Il. 60044 (312)937-5782 Office - (312)234-9022 Home

FOR SALE: Instrument cluster for 1976 EMS with clock/tach. \$125. (317)299-5877 Dick Hamstra, 5724 Diana Dr, Indianapolis, Ind. 46278

FOR SALE: (3) trunks for 96s, gray, biege & green. \$25. each. (913)628-4435 weekends Roger S. Harris, Box 47, Ashfield, MA. 01330

FOR SALE: 1500 1969 V-4 engines. One "excellent cond., 60,000 Solex carb; \$200. Another 'good' cond., Ford carb; \$150. Also many 96 & 95 parts. Nicholas B. Hayden, 3385 W. 86th St., Cleveland, Ohio 44102 1-216-281-9823 or 1-216-431-9413

FOR SALE: 1968 -95 wagon, 100,000 mi., eng. good, trans' just rebuilt, no rust body, dents in fenders. \$650. (607)273-3066 evenings. Will Schweller, 215 Linn St., Ithaca, N.Y. 14850

FOR SALE: V-4 parts (used) & 1969 99 parts-some new. Two cycle parts: pistons, fuel pump parts, much misc. Parts bought from defunct dealer. Also have Bosch Electronic Fuel Injection Test Meter (not for sale). (203)455-9203 Zip: 06235 Bert Gunn, RFD Box 299, Bedlam Rd., Chaplin, CT.

FOR SALE: 1963 parts; Door glass, grill, bumpers, trans'/over drive; \$20. ea. Fenders; \$15. ea. Carb (for 3 cycle), radiator, manual; \$10. ea. Heater coil, flywheel, jack; \$5. ea. Hub caps; \$2. ea. All F.O.B. OR ALL for \$100. F.O.B. (404)634-1371 Zip:30341 Bill Criswell, 2285 Dresden Dr., Chamblee, GA.

FOR SALE: Parts for 3 cyl. & V4. Starters; \$25., generators; \$20.-40., radiators; \$25., wiper mtrs.; \$15., Solex single & triple carbs; \$15.-30. WANTED: '71-73 brown bucket seat covers; \$30. or? Roger Harris, Box 47, Ashfield, MA. 01330 - 413-628-4435 Weekends.

FOR SALE: Parts for 2 cyl. and V4. Also have high performance intakes for V4. Will sell at huge discount. Must make room for new stock. International Auto Spt., Merriam, Kansas 913-384-2626

FOR SALE: Intereurope manual, 1966-71 V4; \$3. Chilton manual, 1960-70 V4, 2 stroke; \$3. or both \$5. Intermediate pipe, new J.C. Whitney for V4, \$7.50 4 plugs Bosch W200T30, new; \$2. (216)746-6897 M. Berger, 1868 Selma, Youngstown, Ohio 44504

FOR SALE: 1974 99LE parts. Hatchback dr. & glass & struts; \$350. Rt. dr. & glass; \$125. Steering whl. & column; \$30. Fan mtr. & housing (cooling); \$40. Fuel pump & fr. & rear bumpers; \$50. ea. hubcap; \$8. Interior, less bucket seats; \$100. (2) 5" whls. \$20. ea. Rear axel; \$25. - (2) tail light housing & lens; \$70. - Dennis E. Minni, 15848 Walnut Cr. Dr., Strongsville, Ohio 44136 -Days: 1-216-696-7330 PM & wknds: 1-216-238-0365

FOR SALE: 99 parts. 1973 cyl. head (2L) w/valves assembled; \$150. 1974 camshaft & bearing assbly (2L); \$100. Carb, manifold & air cleaner; \$125. Engine block stripped (2L); \$100. Shop manual 99 to 1974, no binding; \$15. Crankshaft (2L); \$50. Left dr. white; \$100. Other parts. Zip: 26836 Joseph Sterbutzel, P.O.Box 196, Moorefield, W.VA.

FOR SALE: Unused 99 engine, no head. Asking: \$150. Negotiable. (617)548-5315 Nell Wright, Box 54, Woods Hole, MA. 02543

FOR SALE: 1970 99 bucket seats, fair cond., some wear; \$25. Pair of 14"x 4 3/4" wheels, black; \$20. Or all for \$40. 271-7267 Wknds, eves. only. Zip: 14607 Frank Crombe, 14 Rundel Park, #2, Rochester, N.Y.

FOR SALE: 99 parts, (1971-1973). Factory Trl. hitch; \$40., wiper motor; \$20., heater motor; \$15. Charles E. Curtis, Jr., 503 Piedmont Park Rd. Greenville, S.C. (803)244-4941

Home: 492-8833

Duncan Snowden, 2116 Grant St., Evanston, Il. 60201

FOR SALE: New (1) Pirelli CN36 tire, 175/70HR15 mounted on new 5" Saab wheel. Asking: \$80. M. Perlmutter, 19 Peckham Hill Rd., Sherborn, Mass. 01770

FOR SALE: 99 parts. Head rest cushion; \$30. (green). AM/FM stereo cassette (W/O mount); \$100. Service manual; \$8. & Quartz conversion headlights; \$35. Includes postage. Zip: 54521 Rev. Roger Wharton, Box 608, Eagle River, Wisc.

FOR SALE: New clutch line; \$22. ('74 99LE), used 3-gauge assy. temp gauge inoper; \$55., (2) new 4" speakers from '79 900 with Pioneer covers; \$17. both. Bob Panella, 1139 Taylor Ave., New Kensington, PA. 15068 (412)782-2075 Days.

FOR SALE: 1977 EMS, 66,000 road mi. Loaded, sun roof, air, stereo tape, cruise control, new silver paint, sharp & well cared for. \$5,000. Zip: 68111 Glenn H. Shipley, 7024 N. 79th Plaza, Omaha, Nebr. (402)391-4505 Office - (402)572-1325 Residence

FOR SALE: 1976 Wagon back, 35,000 mi., hit right frt. Eng. & trans' for \$1200. or complete car for \$1,500, or will part out. (408)286-5391

Paul Perry, 966 Schiele Ave., SanJose, CA. 95126

PARTING OUT: 1973 99EMS. Bmprs \$90. ea; Fuel inject. cntrl \$45; press. reg. \$40.; Compl. wire harness \$35. Lots more. Shipping extra. (205)553-9203 Eves. Jim de Haseth, 3017 Greengrove Ln., Tuscaloosa, AL. Zip: 35404

WANTED: 93 750 GT dashboard, w/without instruments & speedpilot. Also complete Sonett III shift mechanism from knob to gearbox; \$50. or? (503)772-5449 97501 Jack Ashcraft, 2425 Table Rock Rd., Medford, OR.

WANTED: Trailer hitch to fit 96; \$15. or? Also 850 MC or oil injected 850 engine; \$150. (206)782-7239 Ron Russell, 6742 1/2 -6th Ave. N.W., Seattle, WA. 98117

WANTED: 1970 or later 96. Excellent shape. Will pay fair price for right car. Fred Sisson, Box 218, Nashville, Indiana 47448

WANTED: Set of alloy wheels (rims) for Sonett; \$150.? Barry Nash, 2360 S. Quebec #205, Denver, Colo. 80231 (303)755-1532

WANTED: Good comprehensive service manual for 1974 99LE 2 liter, about; \$15. (414)442-2476 Brian Sullivan, 3155 N. 93rd St. Milwaukee, Wisc. 53222

WANTED: (4) small type hub caps for 1976 99GL. Offer \$50. or (?). Also need shop manual \$25. or (?) 44118 Irving Sheer, 2179 Vernon Rd., University Hts. Ohio

WANTED: 4 sp. trans' to fit 1971 99E; \$200. Or later year unit; \$? (402) 336-2432 Zip: 68763 John D. Truman, 619 E. Fremont St., O'Neill, Nebr.

WANTED: 2 front bucket seats (high rest), 96, prefer black; \$100. Call collect (404)428-8719 - Also shop manual; \$15.

Ernie Soto, 310 Wylie #44, Marietta, GA. 30067

WANTED: Transmission for 1973 Sonett & wiper mtr. plus all gears; \$200? Frank Magadance, RR2, Box 26, Shakopee, MN. 55379

WANTED: V-4 factory manual, 1967-1973. Offer/\$20. Andy Buc, 7985 Santa Monica Bl., #109-67, Los Angeles, Calif. 90046 (213)980-9983

WANTED: For 1979 99L, complete tach/clock assembly \$50. (713)681-2837 Zip: 77092 Patrick McDaniel, 6210 Golden Forest Dr., Houston, TX.

WANTED: 1972 (early '73) Sonett rear bumper (rubber) good cond., \$45. For body & eng. parts in N. Ohio contact: Howard Davies, 1172 Co. Rd. 2256, Rte. 1, Perrysville, Ohio 44864

WANTED: Two alloy wheels for 1978 99 GLE. Offer \$50. Days: 412-675-3687 - Eves: 412-884-7016 Vern Childress, 4608 W. Brightview, Pittsburgh, PA. 15227

WANTED: Information about ice-racing in New England. M. Perlmutter, 19 Peckham Hill Rd., Sherborn, MA. 01770

(2) *

1967 95, & 96 bodies and 1970 96 all at R & R Wrecking, Springfield, Mass.

Several 3 cyl. 96s, 1971 & 1973 99's, 1972 95, 1978 99EMS, several 1969-70 99's at Highway Auto Salvage, Northampton, Mass.

REBUILDER OF SAABS: Hooksett Saab, Don Levesque, 1 Kennedy Dr., Hooksett, N.H. 03106

WANTED ! WANTED !

Good mechanic/technican who would like to work on Saabs.

Contact: Bob Devlin at Devlin's Alaskan Automotive, 2401 College Rd., Fairbanks, Alaska 99701
Phone: 907-479-2829

SAAB SERVICE INFORMATION

REAR WHEEL BEARING LUBRICATION 1979 99 & 900

There is a possibility that rear axle wheel bearings on 1979 99 vehicles with VIN 99792000001-99792006401 and 99793000001-99793009500 and 1979 900 vehicles with VIN 90791000001-90791032594 and 90792000001-90792003205 have not been lubed with the specified amount of grease. The rear wheel bearings on vehicles having the above VIN's should therefore be relubricated to avoid the possibility of reduced inner bearing life. NOTE: Affected cars delivered from Saab inventory after mid-November, 1979 probably have already been rectified and, if so, have green paint on the bearing cover.

The following procedure will ensure that a proper amount of grease is present:

1. Jack up the rear of the car.
2. Remove the hub cap (steel wheel) or aluminum wheel, the bearing cover, hub nut, washer, and outer bearing. (Leave the outer race in the hub.) NOTE: If cover has green paint on it, it does not need lubrication. Proceed no further.
3. Install lubrication adaptor, P/N 89 96 431. Align the adaptor's outlet pipe with one of the two recesses in the hub.

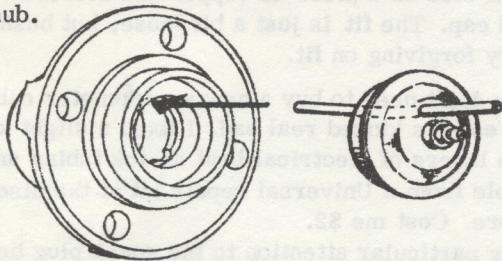

4. Pump grease through the adaptor until it flows from the outlet pipe.

CAUTION - Use extra care when using a high pressure grease gun. Too much pressure can force the inner grease seal out of the hub.

5. Remove the adaptor and excess grease from the outer end of the hub.
6. Reinstall the outer bearing, washer, and a new lock nut, P/N 89 34 697. Carefully torque the lock nut according to the following procedure:

- a. Tighten the lock nut to a torque of 36 ft. lbs. (49Nm / 5 kpm) while rotating the wheel. (This will seat the bearing.)

- b. Loosen the nut relieving all tension (do not allow wheel to rotate).

- c. Retorque to 1.4-2.9 ft. lbs. (17-35 inch lbs, 2-4 Nm/O.2-0.4 kpm) with wheel rotating, and secure nut by staking the flange into the locking groove of the axle stub.

NOTE: Use of a round point punch will prevent fracturing the flange while staking. If absolutely necessary, a lock nut may be reused one time but only if it is not reused on the same axle (i.e., so that it will be staked in a different place), is in good condition after unstaking and has had its threads chased by a tap so that correct torque readings are obtained.

7. Install the bearing cover in the hub. Paint bearing cover with green paint to indicate the lube was done.
8. Reinstall hub cap or wheel.

NOTE: Special tool 8996431 is being supplied to all dealers concurrent with issuance of this Service Info.

FROM: Daniel L. David, Mgr., Technical Services Dept., Saab-Scania DATE: November 30, 1979

WATER COOLED OIL COOLER - 1980 900

A new shorter oil line from the transmission to the oil cooler was introduced beginning with VIN 90801003275 and 90802000943. If improperly installed, this hose can develop a kink reducing oil circulation.

Examine the hoses on all cars between VIN's 9080100-3275 to 8658 and 90802000943 to 2675. If a kink exists or there is indication that one could form, alter the hose connections as follows:

1. Rotate the connector on the oil cooler 20 degrees toward the engine.
2. Rotate the connector on the gearbox so that it points straight forward (horizontal).

This is to be checked as part of the PDI. See special message printed on SSSR form of affected vehicles.

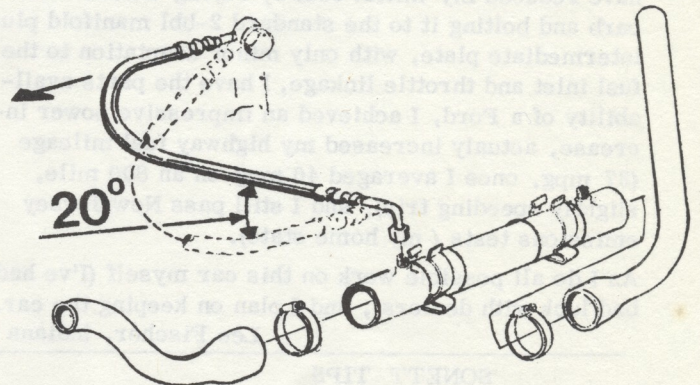

900 EMS FIX OF TEMPERATURE CONTROL

Only problem has been vibration of temp. control connecting rod around 2600 rpm. Fixed by using a 6" long piece of Goodyear gas line hose, split on one side lengthwise, and wrapped around the connecting rod.

Wendell R. Miller, Los Angeles, CA.

We do have a few more tech tips, but room must be made for the enclosed Dealer & Mechanics List. This Issue goes to press Monday JAN. 7, 3:30 P.M.

SAAB CLUB JAN. 1980

Please use knife/letter opener

JAN 1980

FIRST CLASS

RETURN POSTAGE GUARANTEED

c/o R.M. Grossman
Box # 60272
Chicago, Ill. 60660



FIRST-CLASS MAIL
U.S. POSTAGE
PAID 15¢
PERMIT NO. 1793

ADAPTED PINTO 2-BARELL CARB-SONETT

I own a 1973 Sonett III, to which I've recently adapted a Ford Pinto 2-barell carb. The interesting thing about the conversion was that this particular carb is made by Holley, under license from Weber, and consequently I have reduced my initial cost by buying a reconditioned carb and bolting it to the standard 2-bbl manifold plus intermediate plate, with only minor adaptation to the fuel inlet and throttle linkage, I have the parts availability of a Ford, I achieved an impressive power increase, actually increased my highway fuel mileage (37 mpg, once I averaged 40 mpg on an 800 mile, slightly speeding trip), and I still pass New Jersey emissions tests (my home state).

As I do all possible work on this car myself (I've had bad luck with dealers), and I plan on keeping the car.
Lee Fischer, Indiana

SONETT TIPS

When I disassembled the wiper motor I noticed that the brushes were installed wrong, (rotated 90 degrees in their sockets) so that the seating surface was perpendicular to the commutator. The braided leads were too short to rotate them so I wrapped sandpaper around the commutator to make a new seating and reassembled with silicone rubber.

I had problems with gas fumes with over 1/2 tank. One of our members suggested resealing the sending unit. Mine was leaking but didn't solve the problem. I removed the hold down straps and found the vent hose was

12.

so close to the frame over the tank it was deforming the hose and after 130K miles had worn through.

Usually when a person works on his own cars its just for 'love of tinkering' and not just to save money. So I couldn't help figure how much per hour I saved by putting a new front bushing in the starter instead of buying another. A free electrical check at Sears revealed a 200 amp. drain while cranking. I used a standard drill size on a piece of copper and soldered it into the end cap. The fit is just a bit loose, but bushings are very forgiving on fit.

You don't need to buy a new speedometer cable housing unless its kinked real bad. I fixed a slight kink with two layers of electrical heat shrink tubing and a new cable from a Universal repair kit at the discount auto store. Cost me \$2.

Pay particular attention to the spark plug behind the alternator. If the wiring harness or spark plug is old it will arc-over. Check it at night or slip a piece of paper between them and check for burns.

David Funk, Ignacio, CA.

WILL A 2 STROKE TRANS FIT A V-4?

Not too long ago I put a 2-stroke ring and pinion gear (5.43:1) into my rally 96 V-4. The easiest way to do this is to just put a 2-stroke transmission complete with ring and pinion gear onto a V-4 bell housing. This should work fine since for all intents and purposes the two transmissions are exactly alike. This modification gives excellent results . G. Ostlund, Cleveland Hts., Ohio